



US00D466174S

(12) **United States Design Patent**
Neumann

(10) **Patent No.:** **US D466,174 S**

(45) **Date of Patent:** **** Nov. 26, 2002**

(54) **WHEEL**

(75) Inventor: **Steffen Neumann**, Kirn (DE)

(73) Assignee: **Muller & Meirer Lederwarenfabrik**
(DE)

(**) Term: **14 Years**

(21) Appl. No.: **29/149,316**

(22) Filed: **Feb. 22, 2001**

Related U.S. Application Data

(63) Continuation-in-part of application No. 29/116,065, filed on Dec. 23, 1999, now abandoned.

(30) **Foreign Application Priority Data**

Jun. 24, 1999 (DE) 4 99 06 115

(51) **LOC (7) Cl.** **21-02**

(52) **U.S. Cl.** **D21/779**

(58) **Field of Search** D21/760-765,
D21/779, 563; 280/11.2, 11.19, 11.22-11.28;
301/5.3, 5.1, 64.1, 65, 37.1, 64.7, 5.7; D12/204-213

(56) **References Cited**

U.S. PATENT DOCUMENTS

D107,515 S	*	12/1937	Grange et al.	D21/779
D192,928 S	*	5/1962	Reynolds	D21/779
D380,804 S	*	7/1997	Gulla et al.	D21/779
D391,331 S	*	2/1998	Lee	D21/779
D403,729 S	*	1/1999	Portzline	D21/779
5,967,618 A	*	10/1999	Wimmer	301/5.3
5,979,992 A	*	11/1999	Calderone	301/5.3
6,036,278 A	*	3/2000	Boyer	301/5.3
6,039,330 A	*	3/2000	Hoskin	280/11.2

OTHER PUBLICATIONS

“Automobile”, p. 103, Sep. 1996.*

* cited by examiner

Primary Examiner—Raphael Barkai

(74) *Attorney, Agent, or Firm*—R. W. Becker & Assoc.; R. W. Becker

(57) **CLAIM**

The ornamental design for a wheel, as shown and described.

DESCRIPTION

FIG. 1 is a front view of a wheel showing one embodiment of my new design and shows a tire thereon;
 FIG. 2 is a side view thereof;
 FIG. 3 is a back view thereof
 FIG. 4 is a top view thereof;
 FIG. 5 is a perspective view thereof;
 FIG. 6 is a front view of a modified embodiment having four spokes;
 FIG. 7 is a side view thereof;
 FIG. 8 is a back view thereof;
 FIG. 9 is a top view thereof;
 FIG. 10 is a perspective view thereof;
 FIG. 11 is a front view of a modified embodiment having five spokes;
 FIG. 12 is a side view thereof;
 FIG. 13 is a back view thereof;
 FIG. 14 is a top view thereof;
 FIG. 15 is a perspective view thereof;
 FIG. 16 is a front view of a modified embodiment having six spokes;
 FIG. 17 is a side view thereof;
 FIG. 18 is a back view thereof;
 FIG. 19 is a top view thereof;
 FIG. 20 is a perspective view thereof;
 FIG. 21 is a front view of a modified embodiment having seven spokes;
 FIG. 22 is a side view thereof;
 FIG. 23 is a back view thereof;
 FIG. 24 is a top view thereof; and,
 FIG. 25 is a perspective view thereof.

The broken lines shown in FIGS. 1-25 are for illustrative purposes only and form no part of the claimed design.

1 Claim, 5 Drawing Sheets

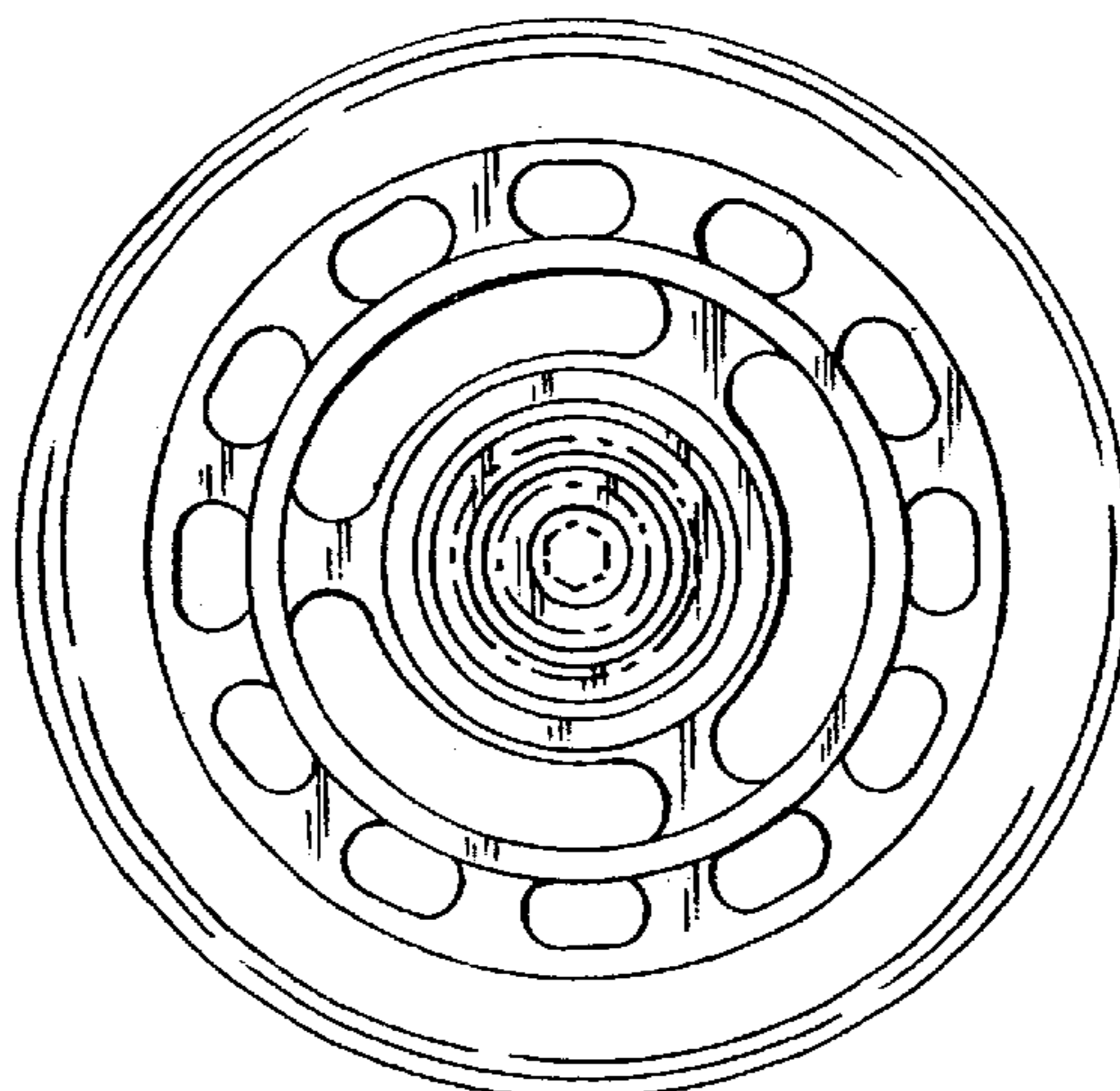

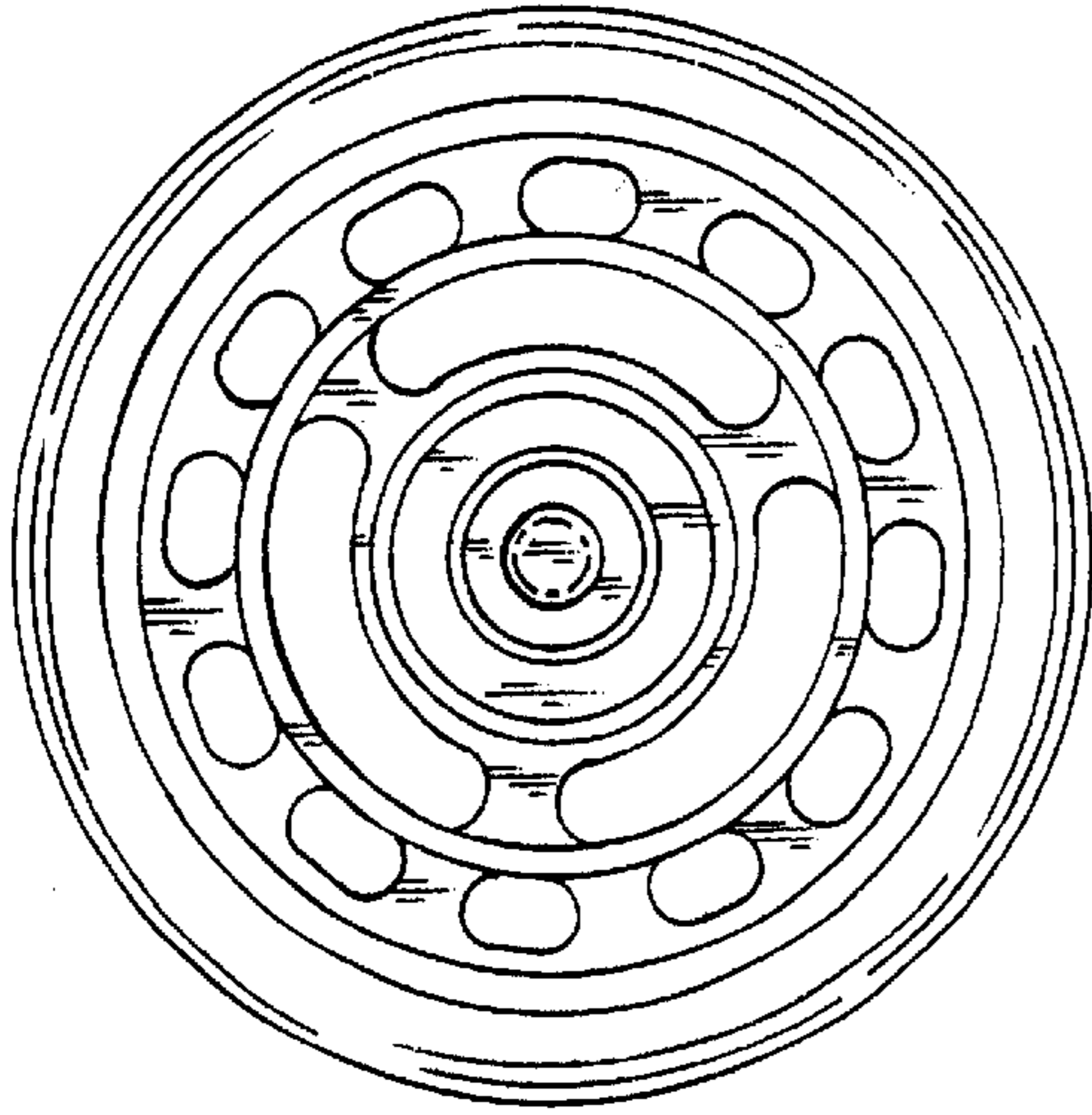

FIG-3

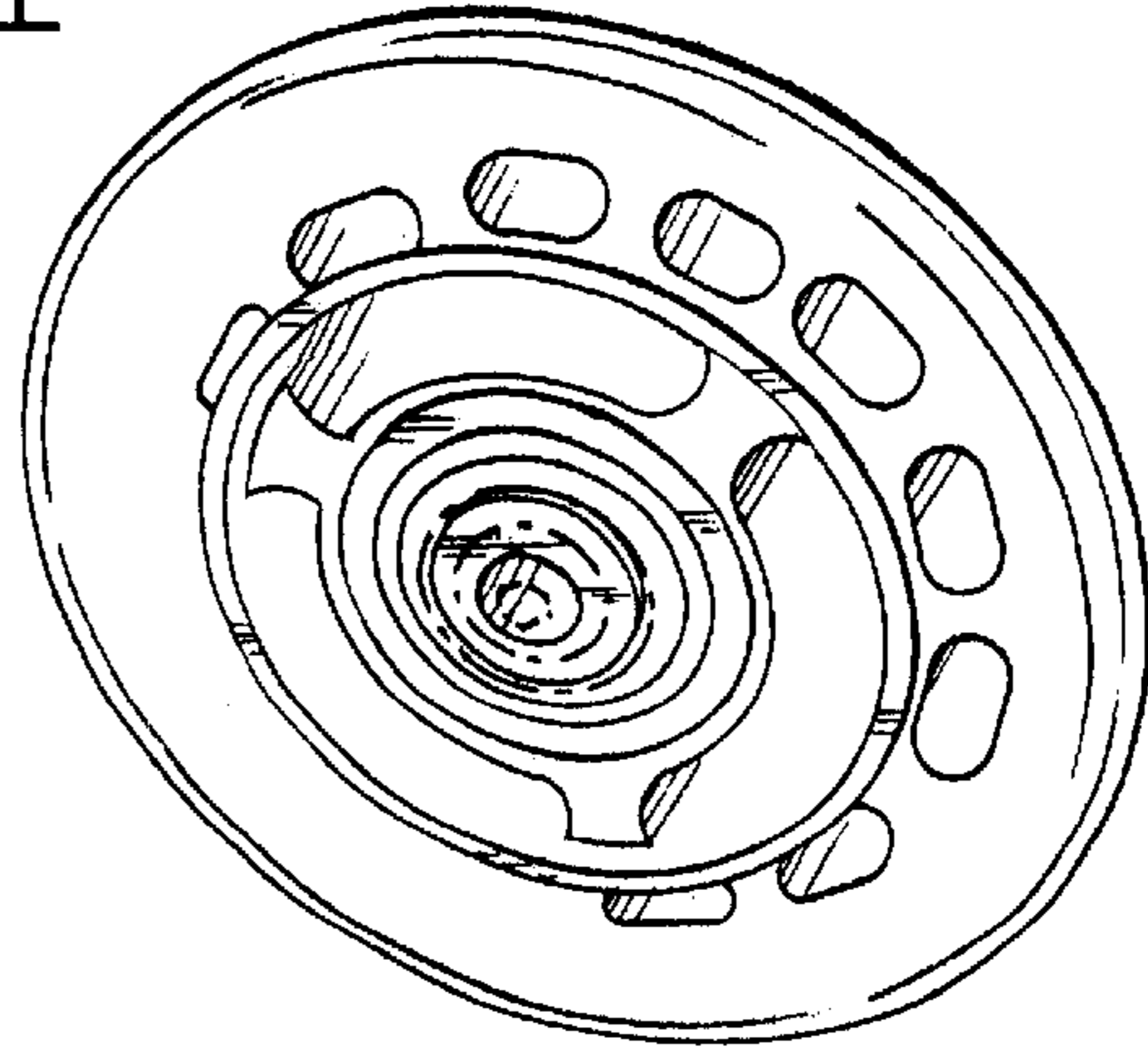

FIG-5

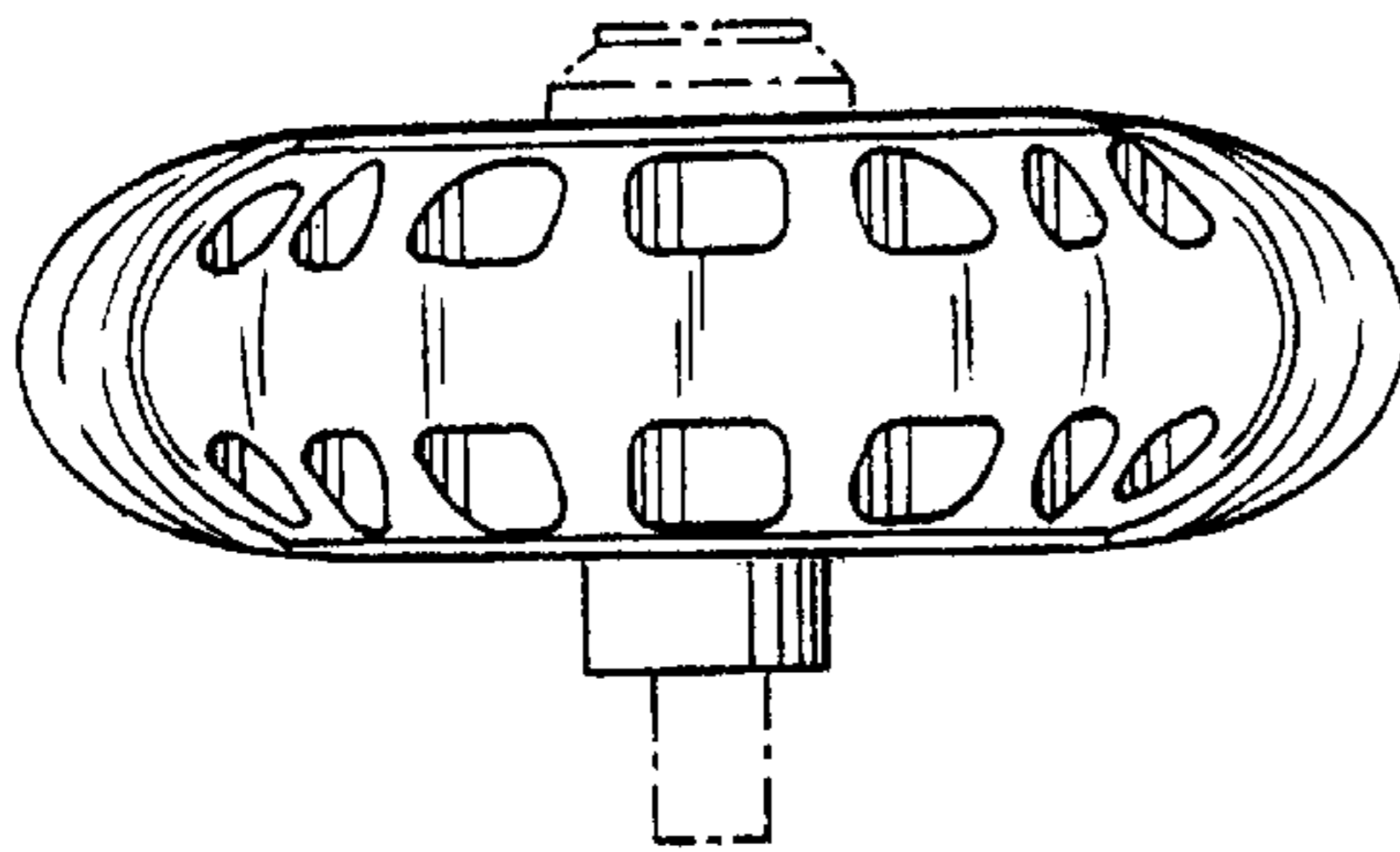

FIG-2

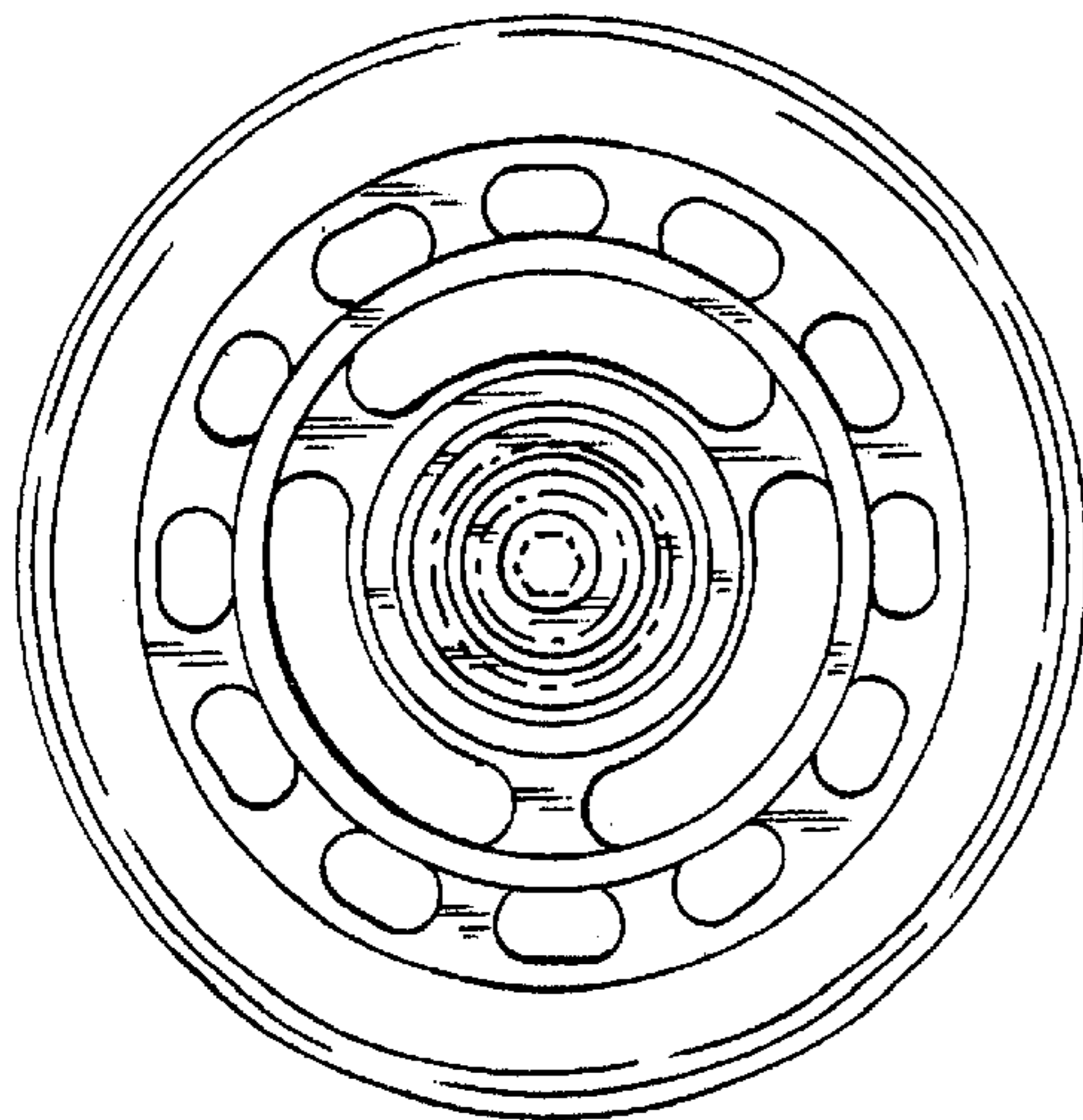

FIG-1

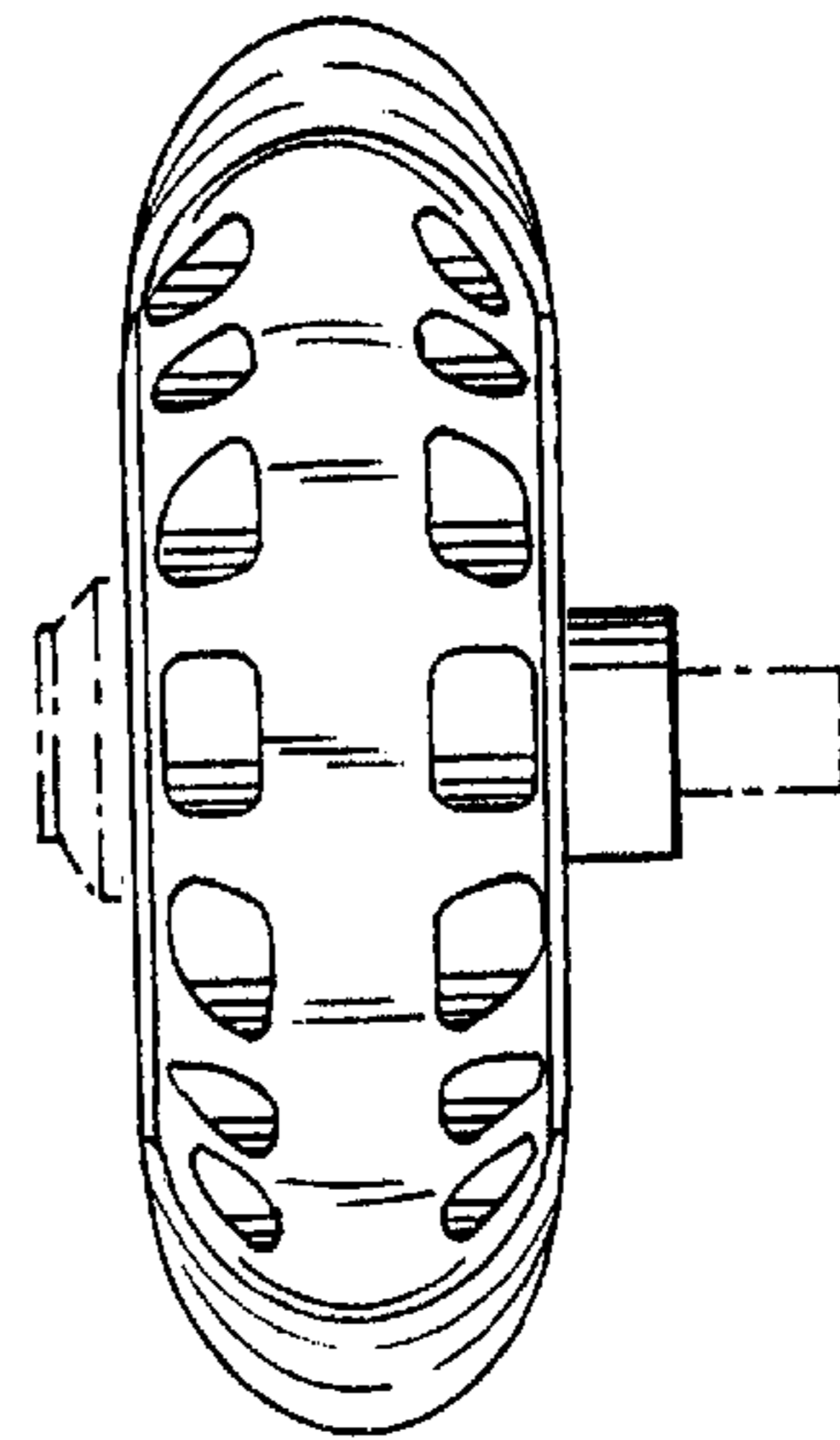

FIG-4

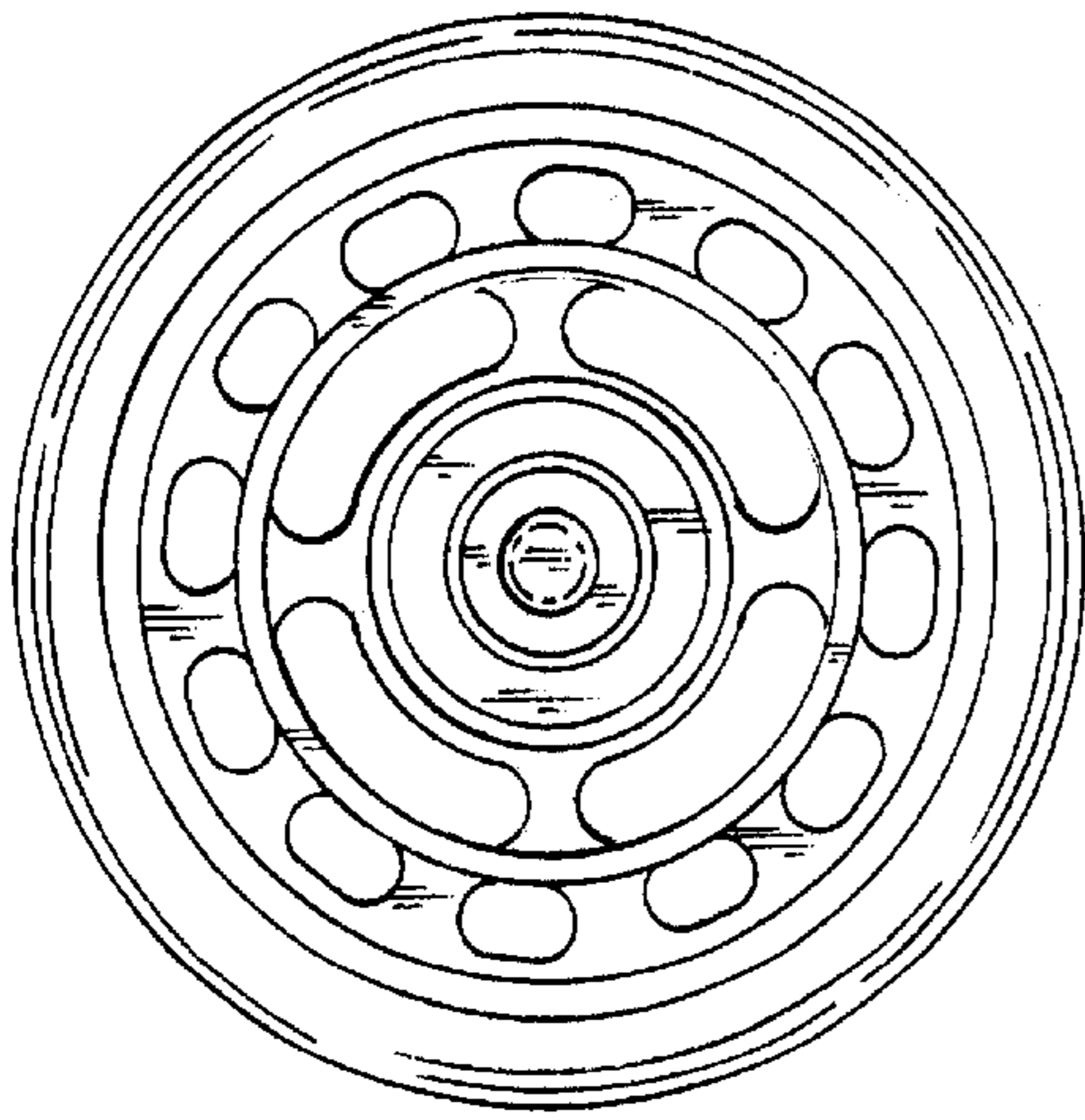

FIG-8

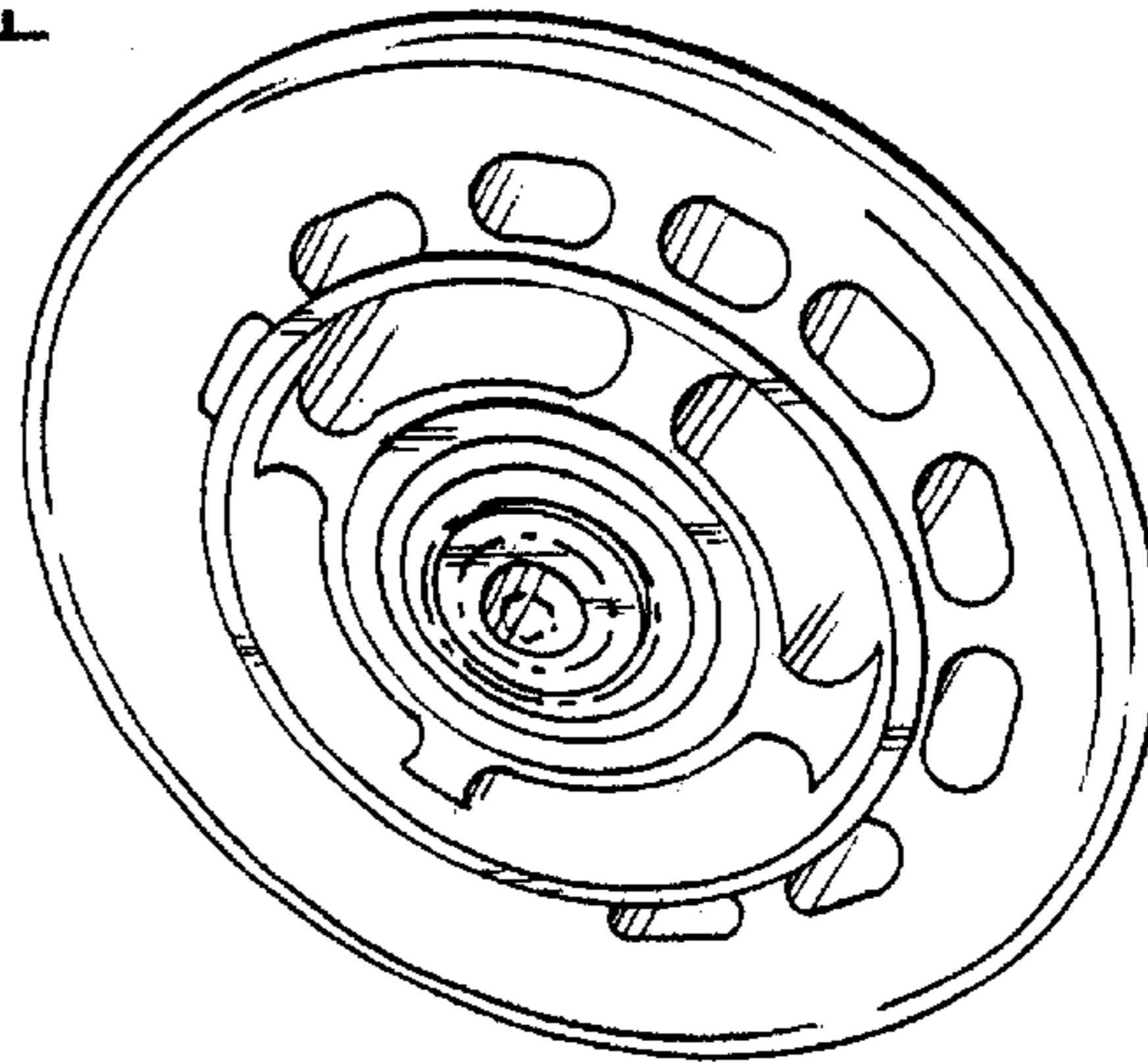

FIG-10

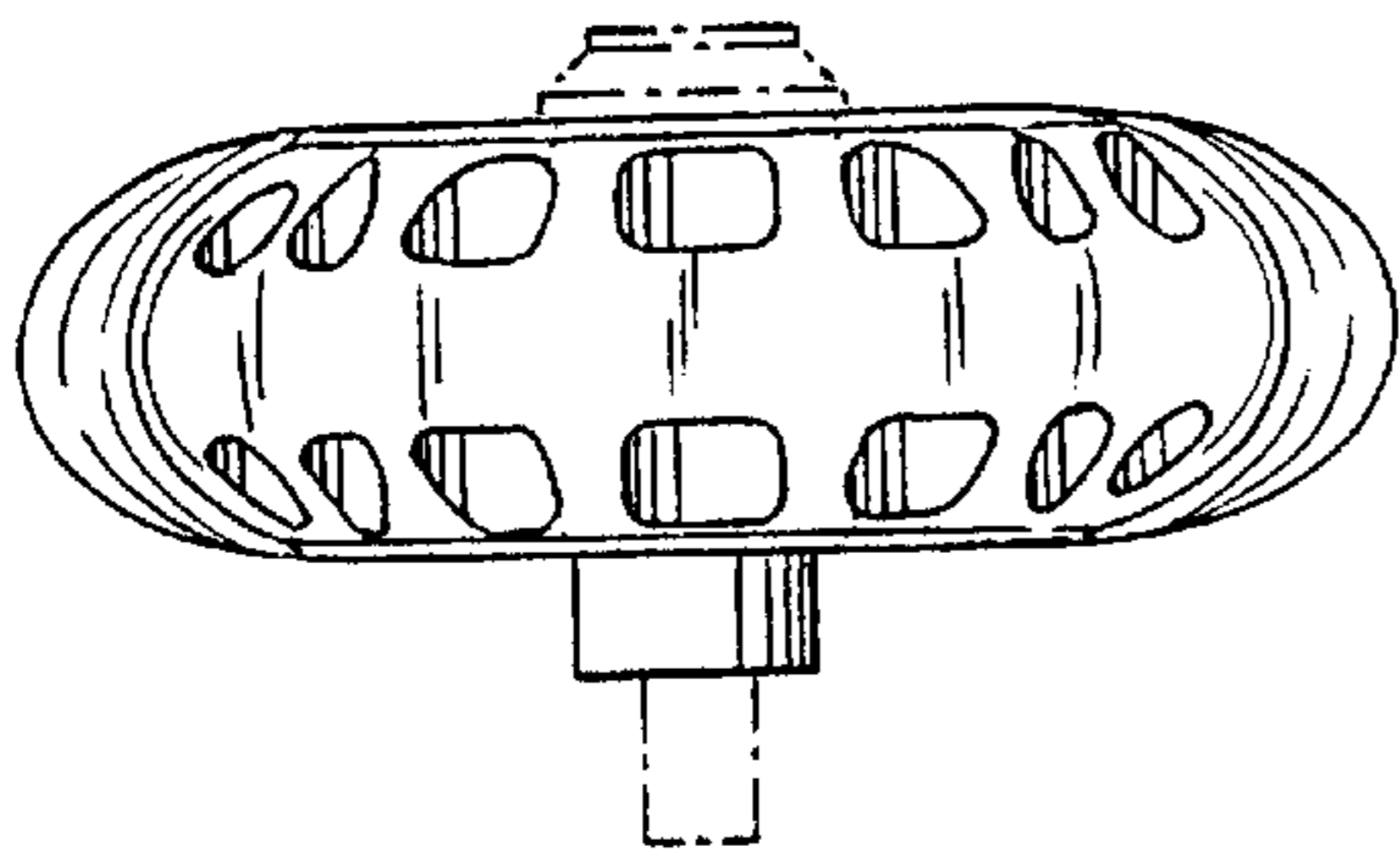

FIG-7

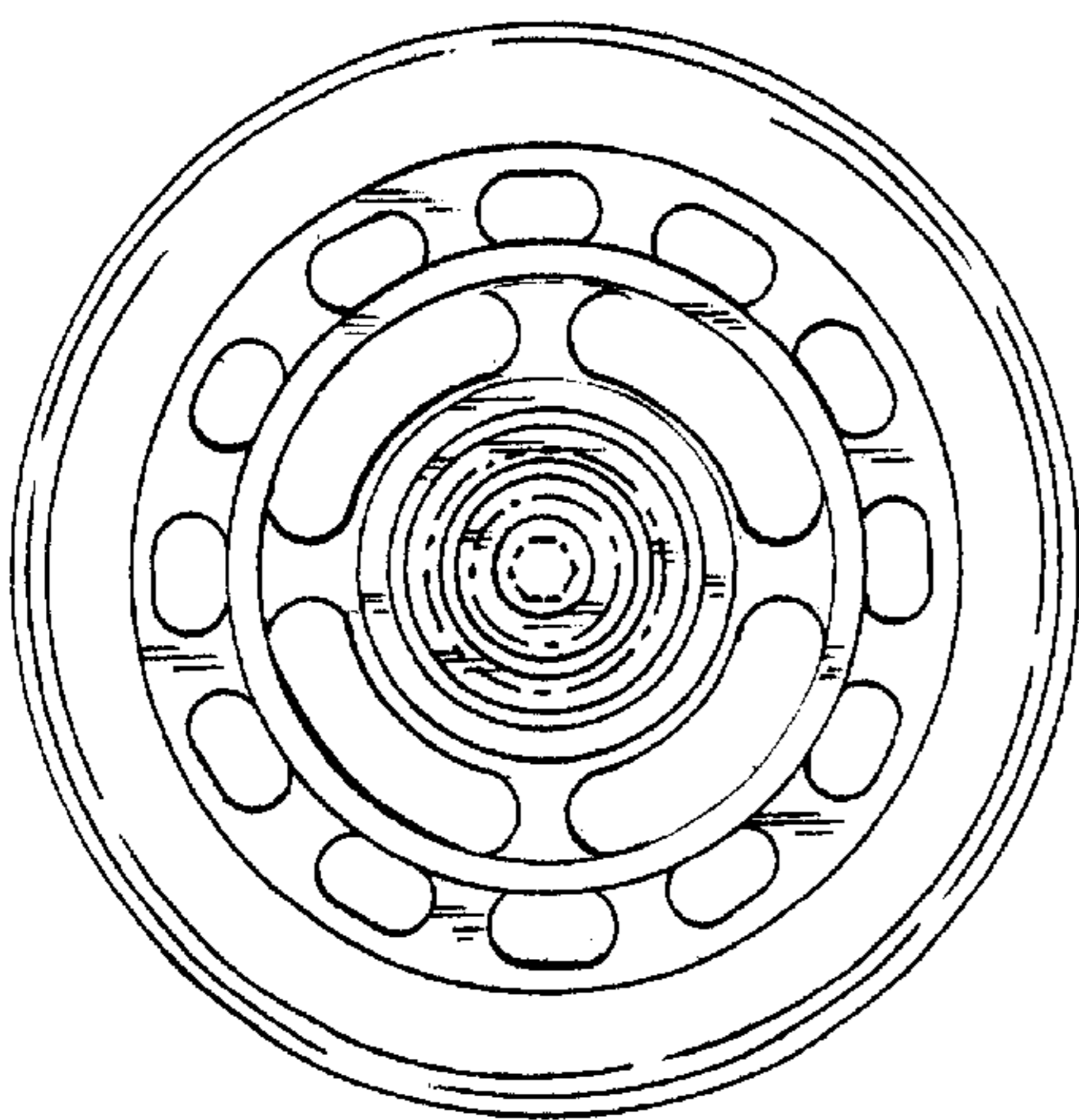

FIG-6

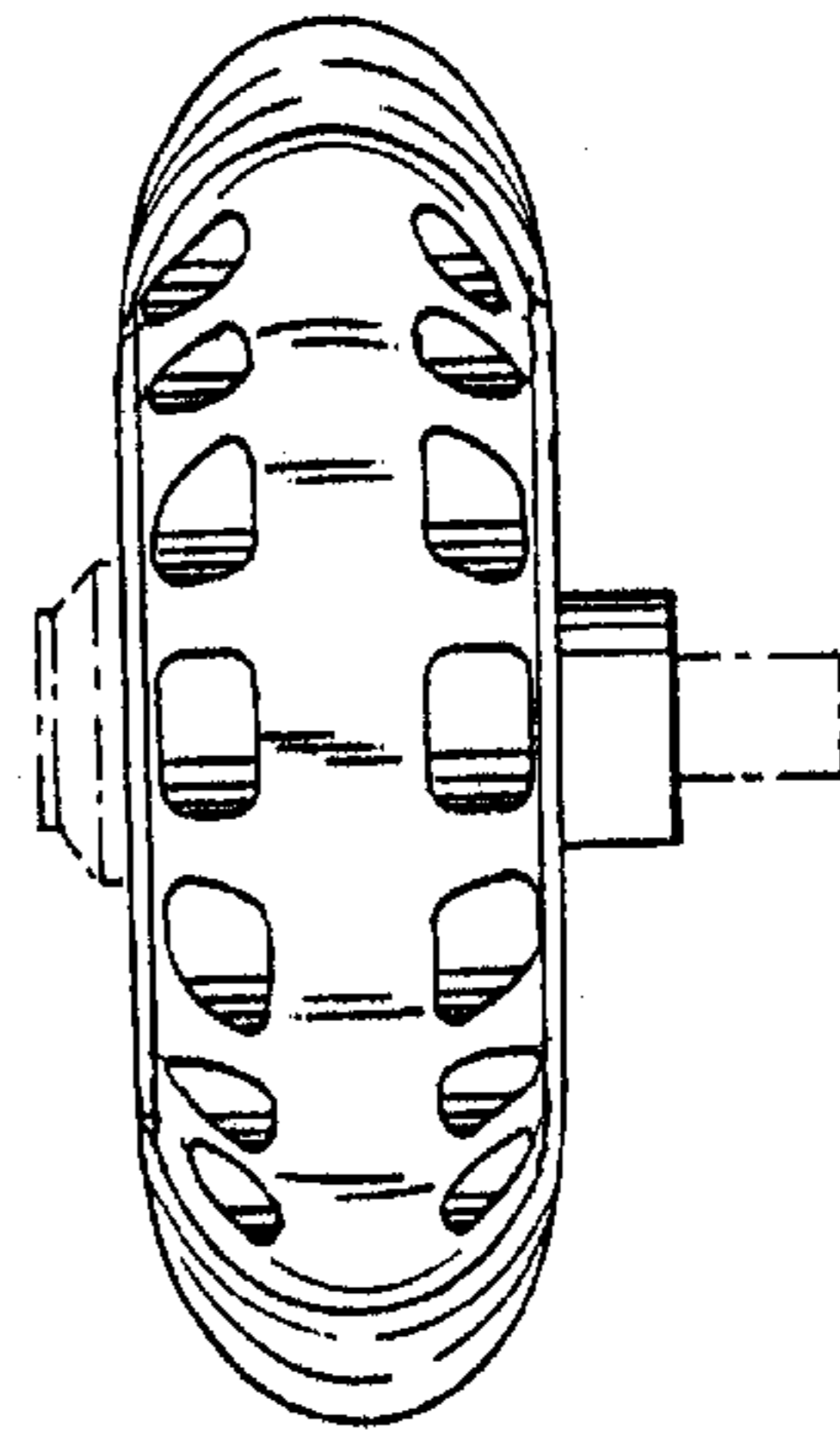

FIG-9

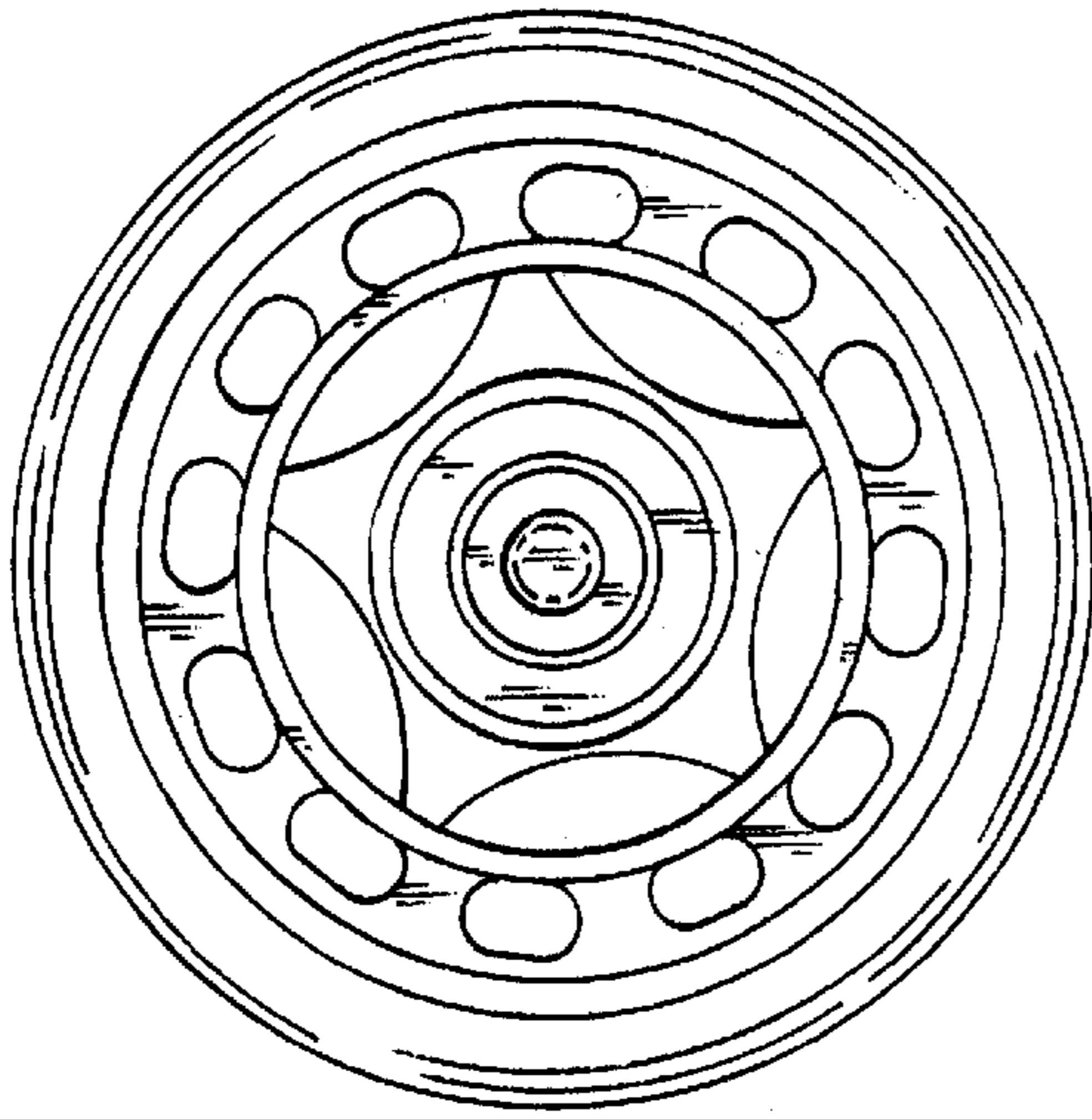

FIG-13

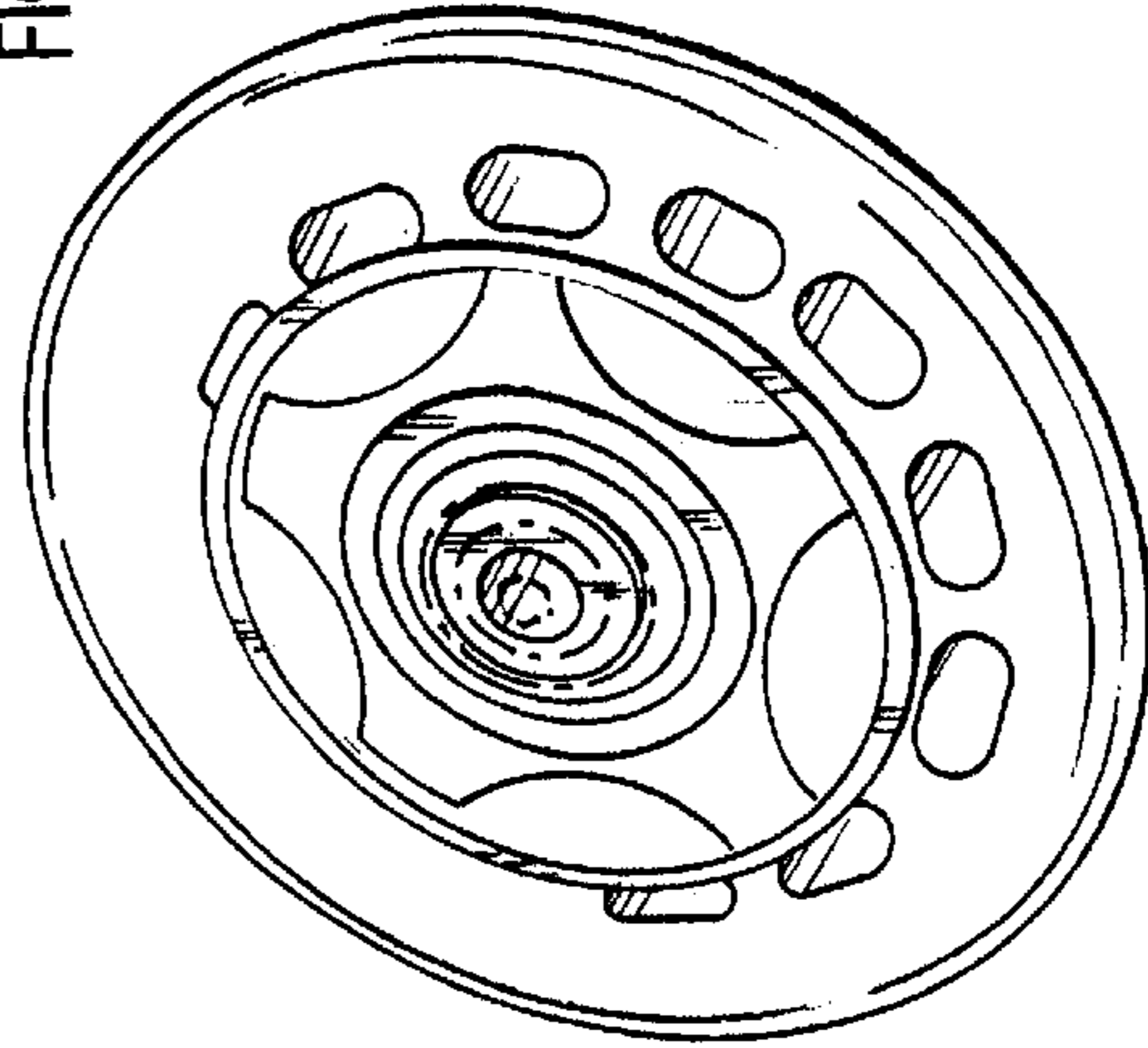

FIG-15

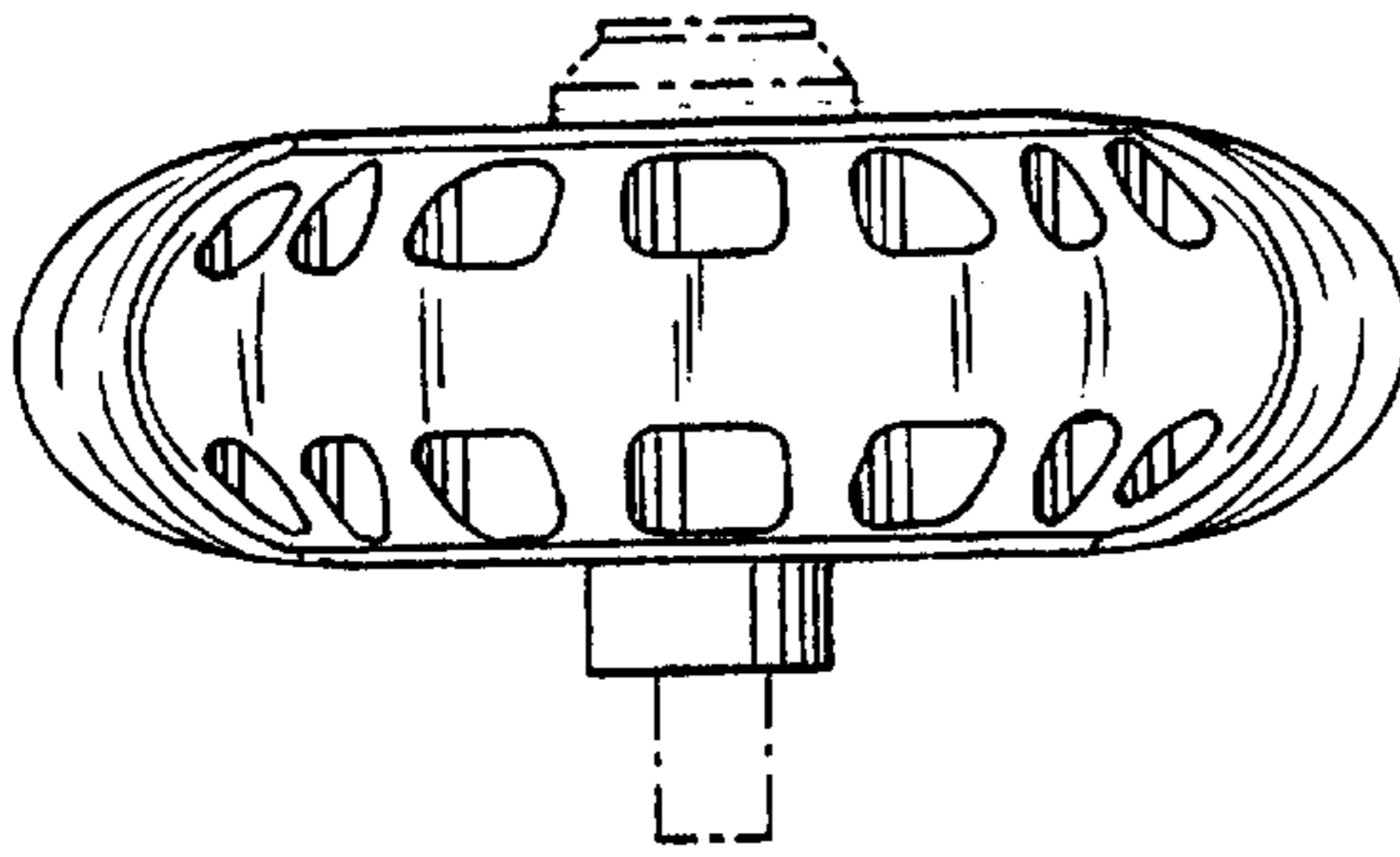

FIG-12

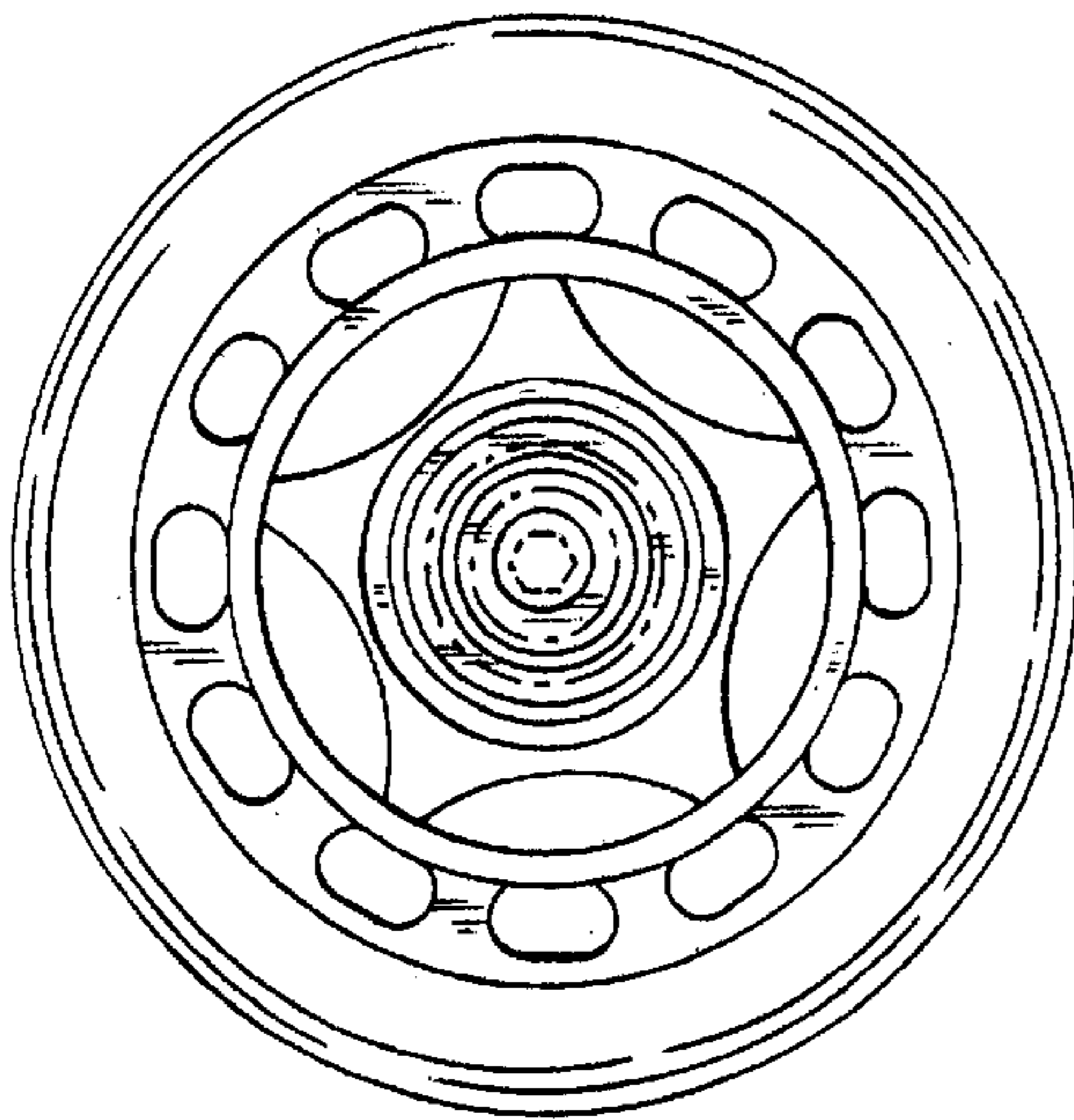

FIG-11

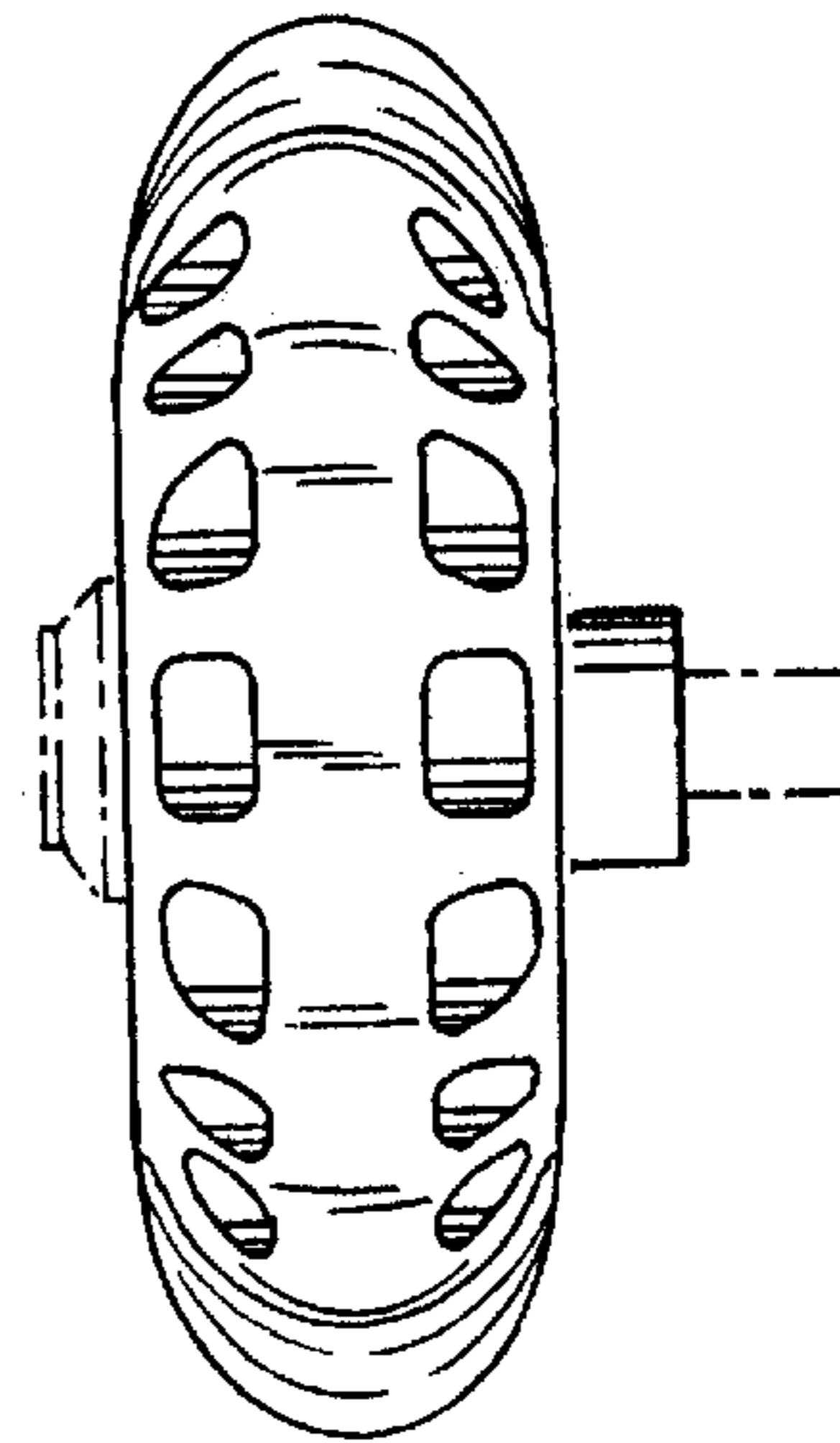

FIG-14

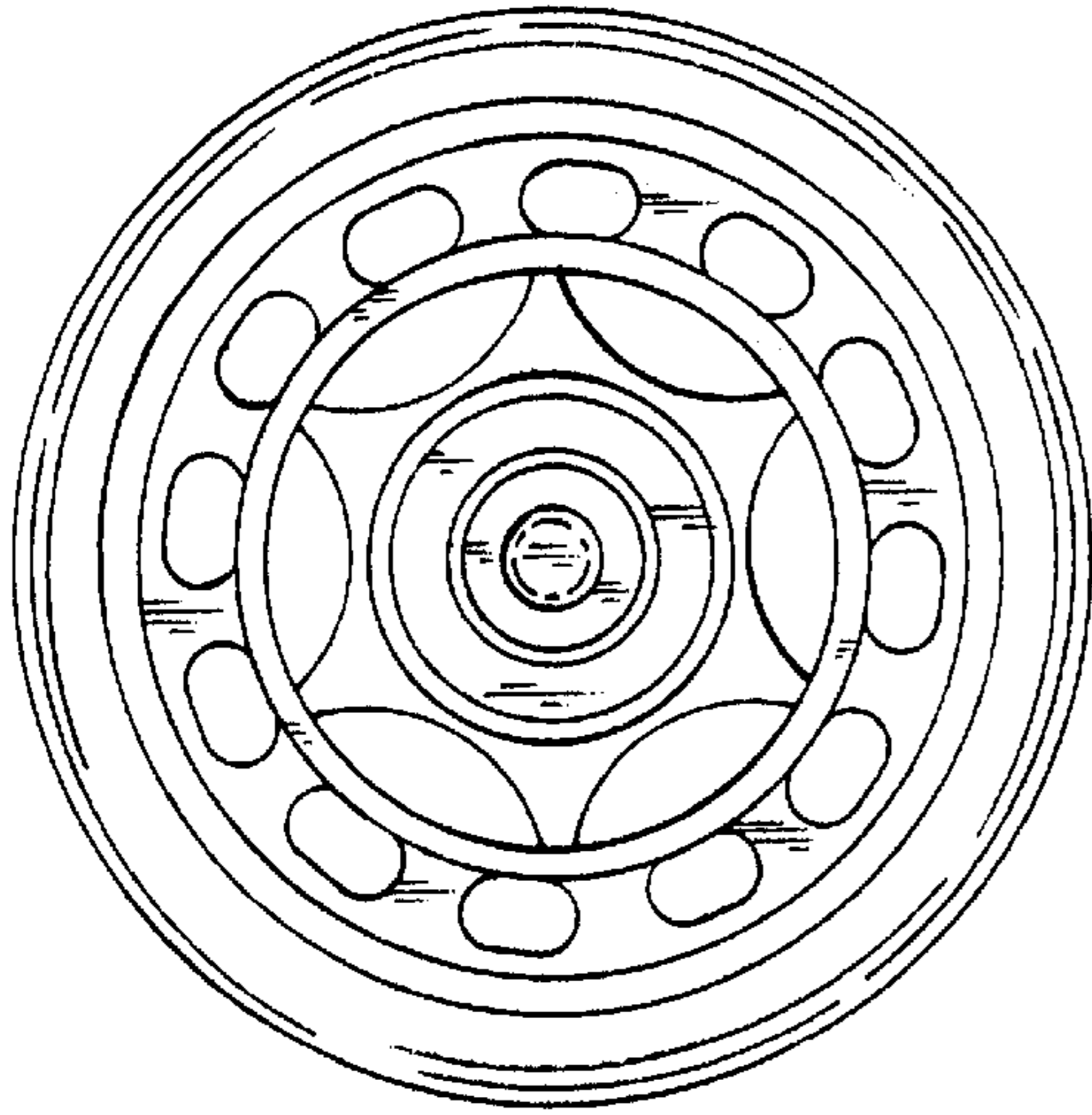

FIG-18

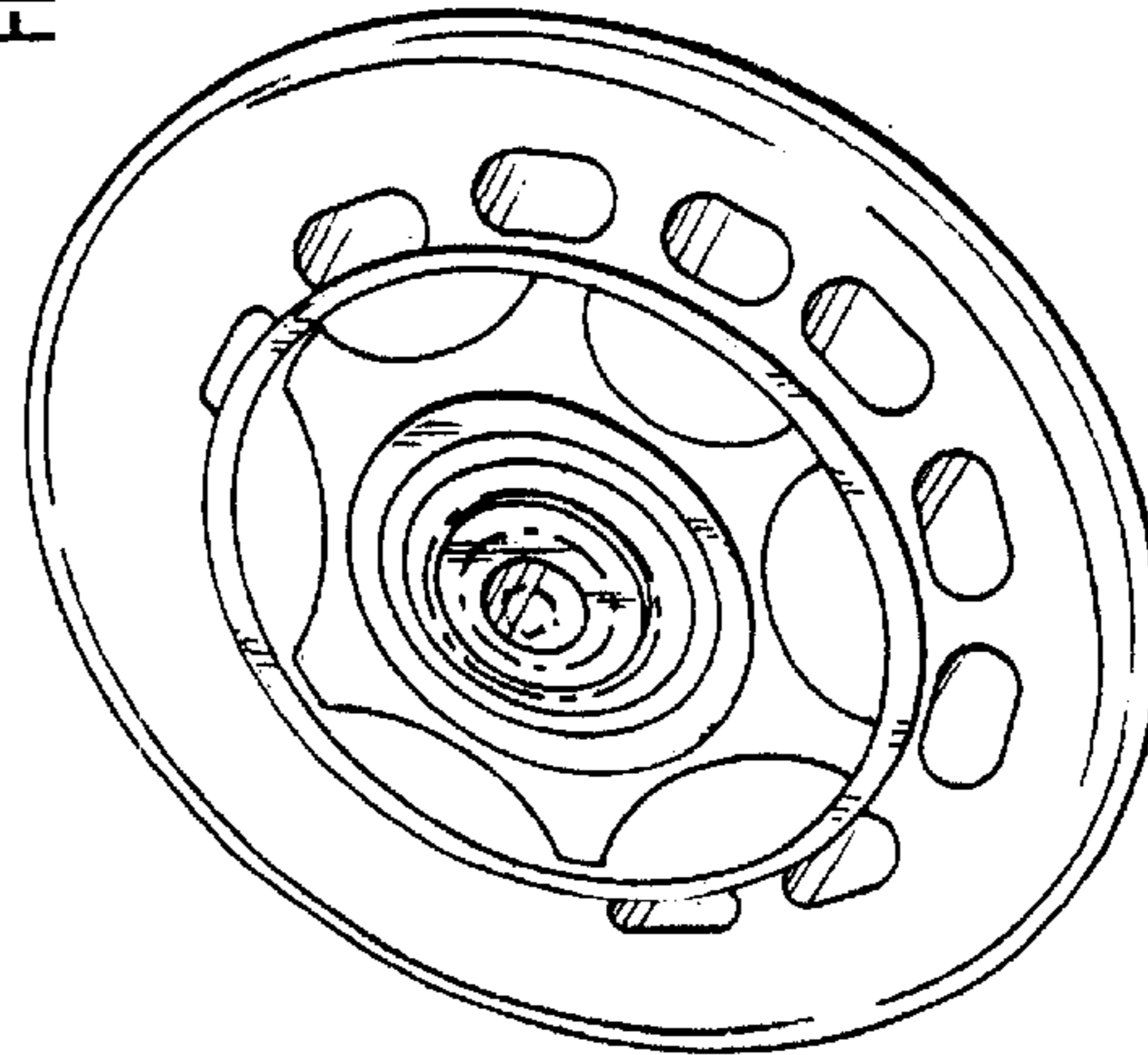

FIG-20

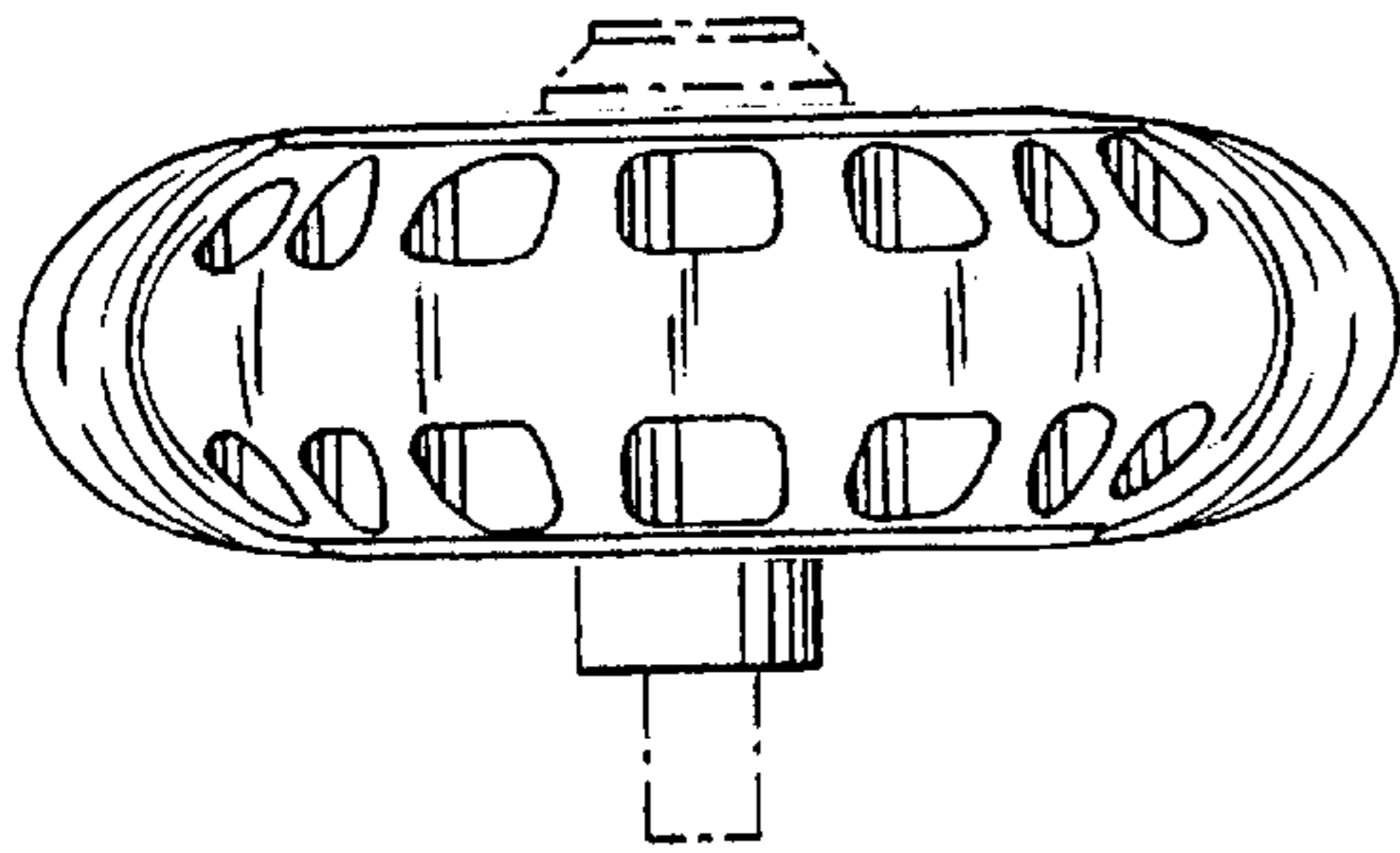

FIG-17

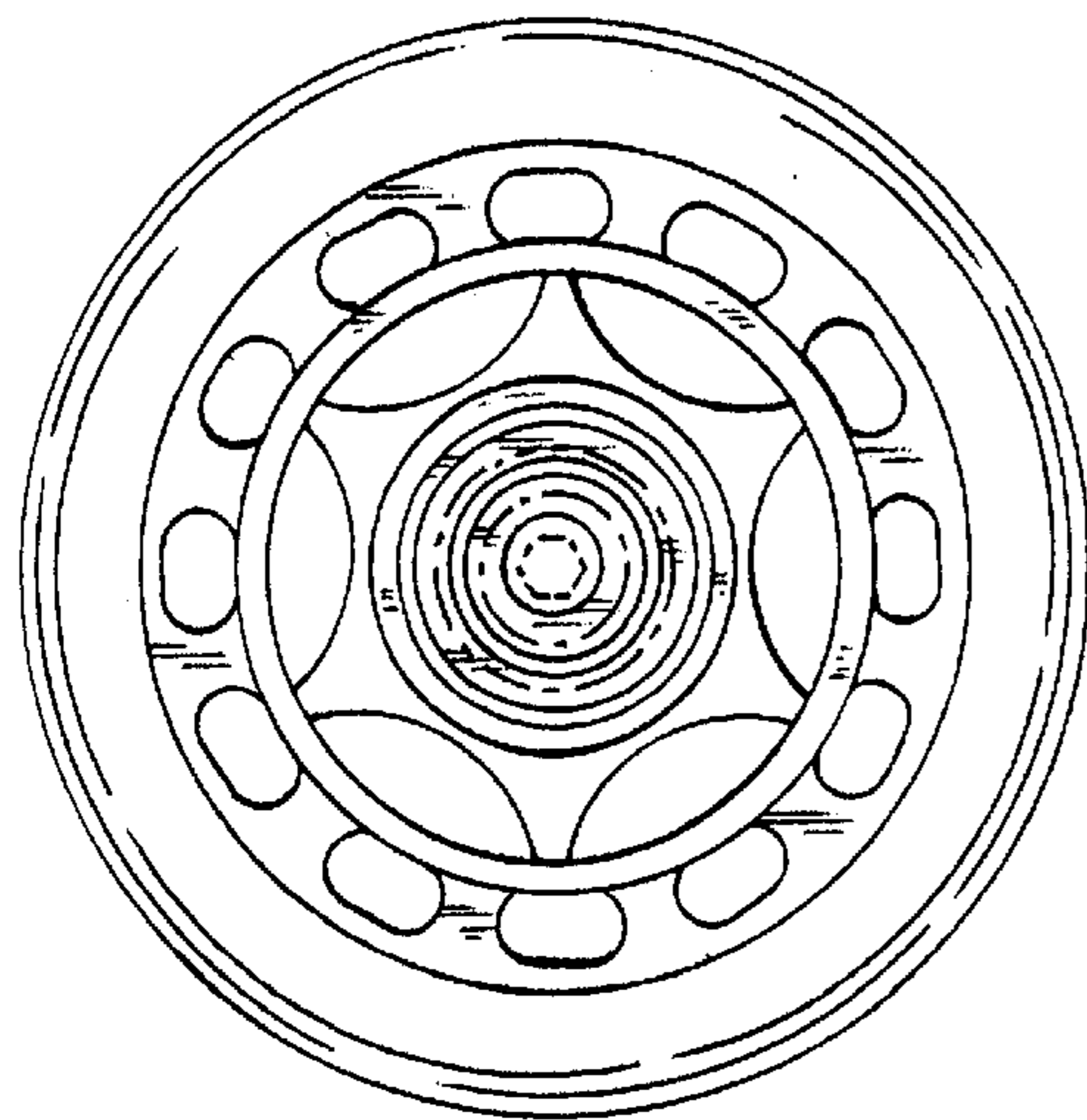

FIG-16

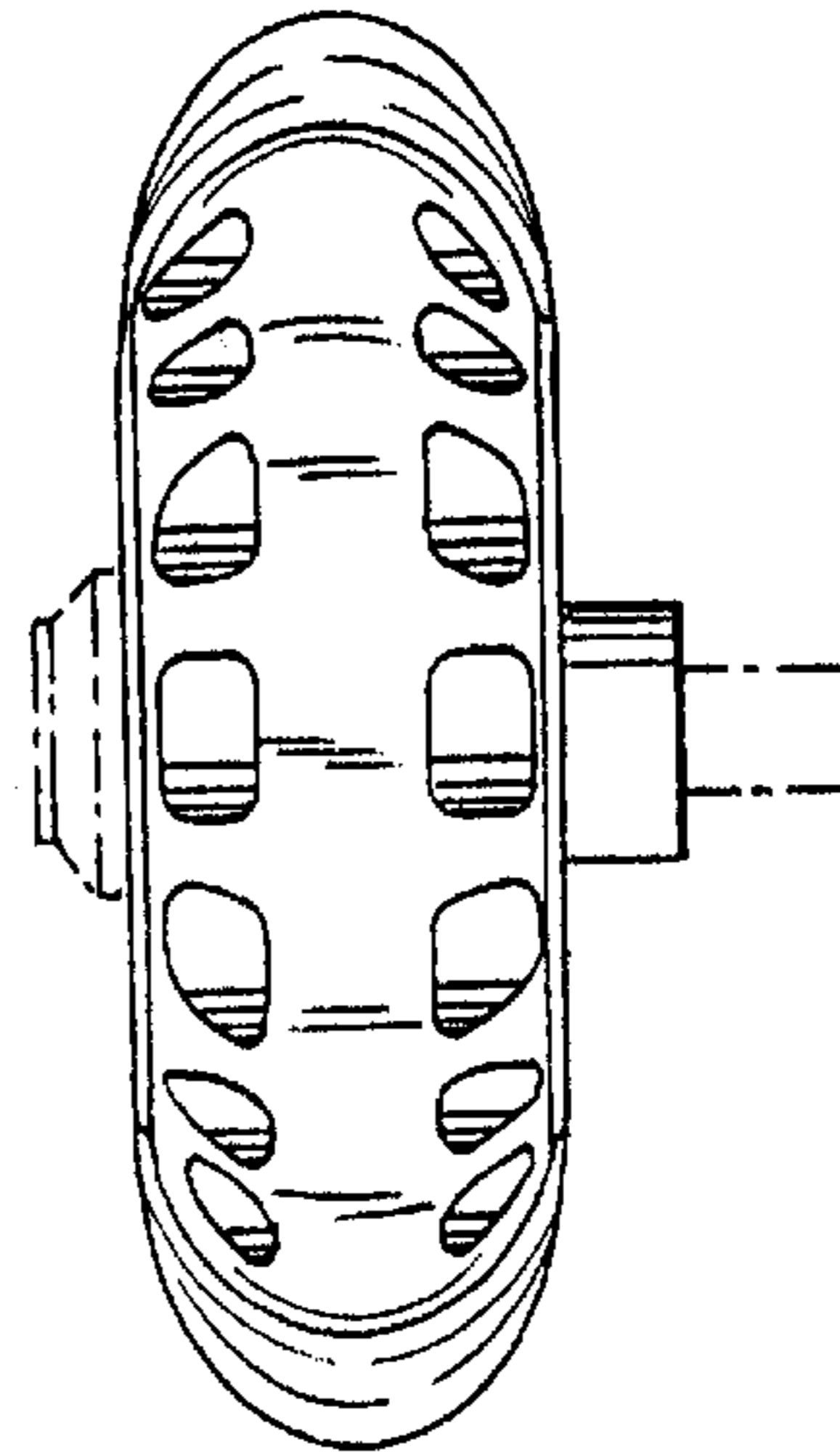

FIG-19

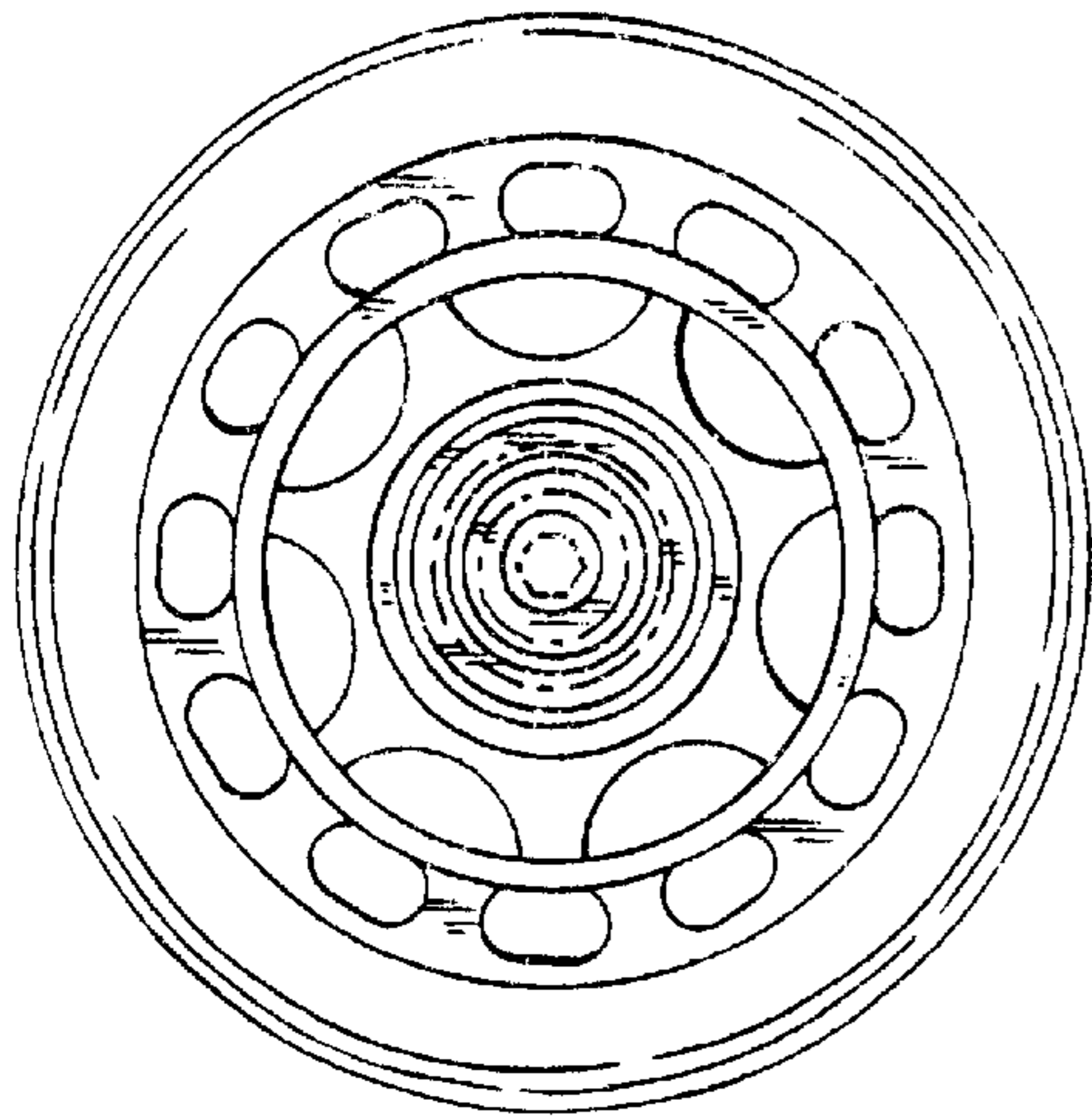

FIG-21

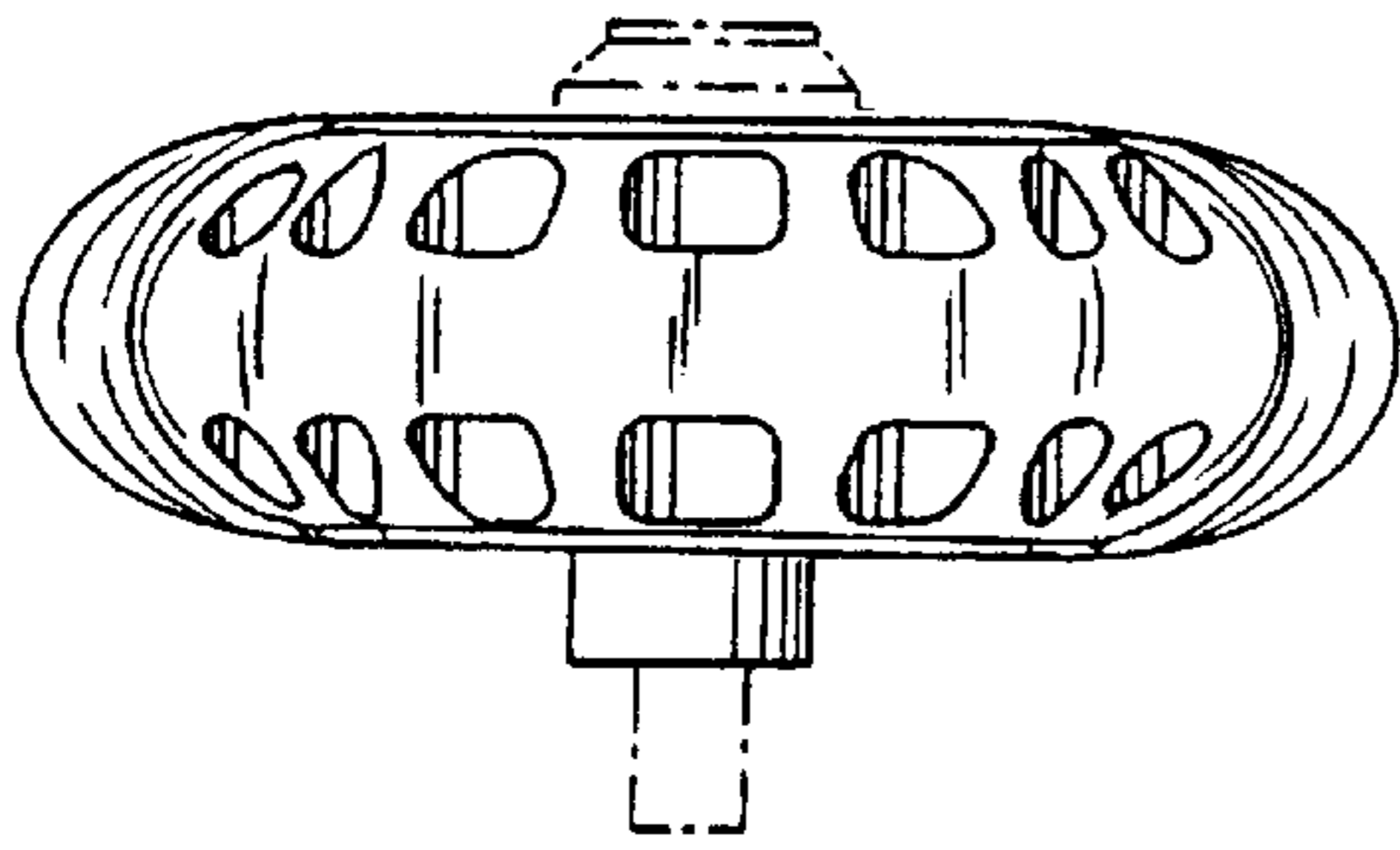

FIG-22

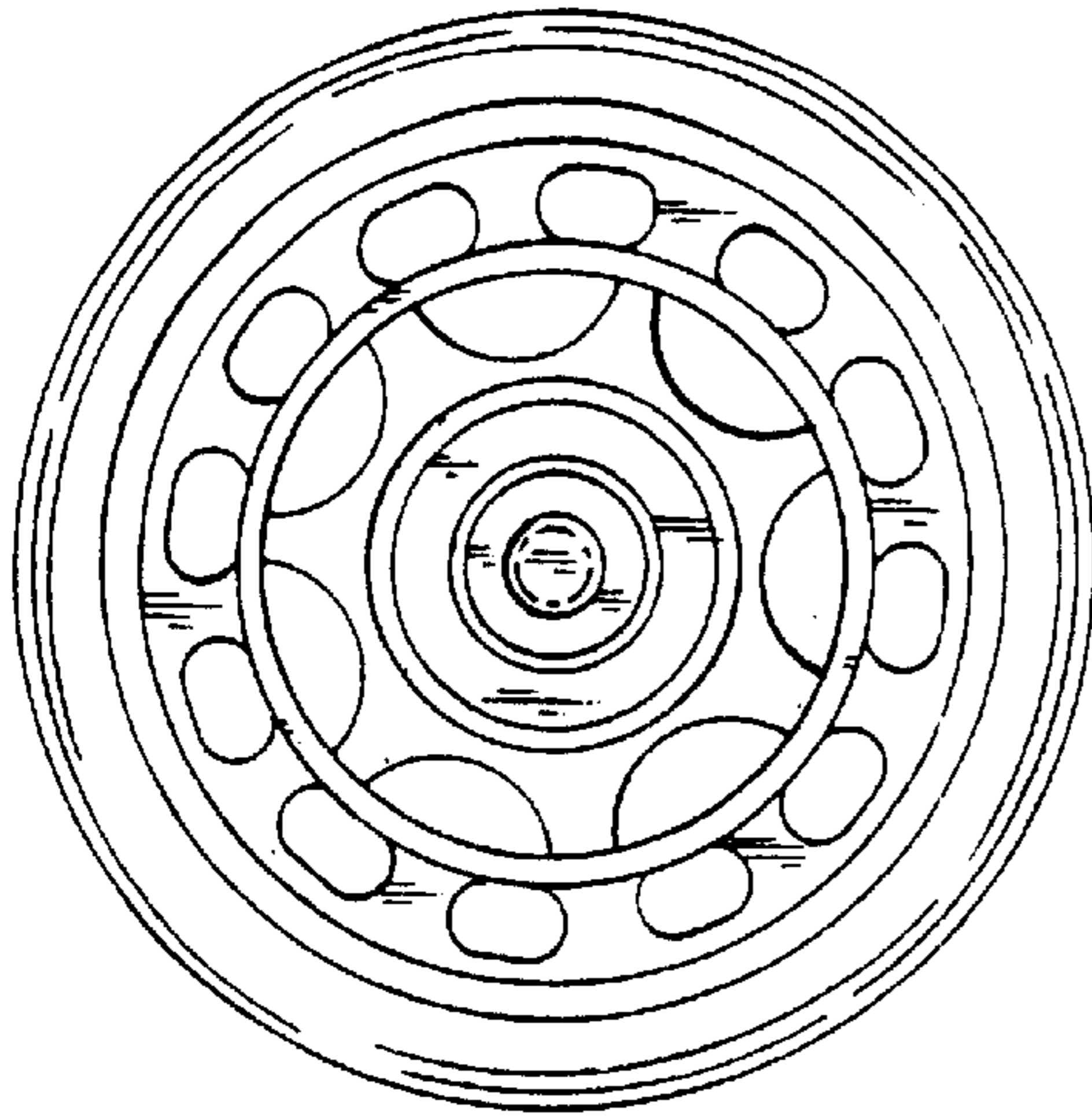

FIG-23

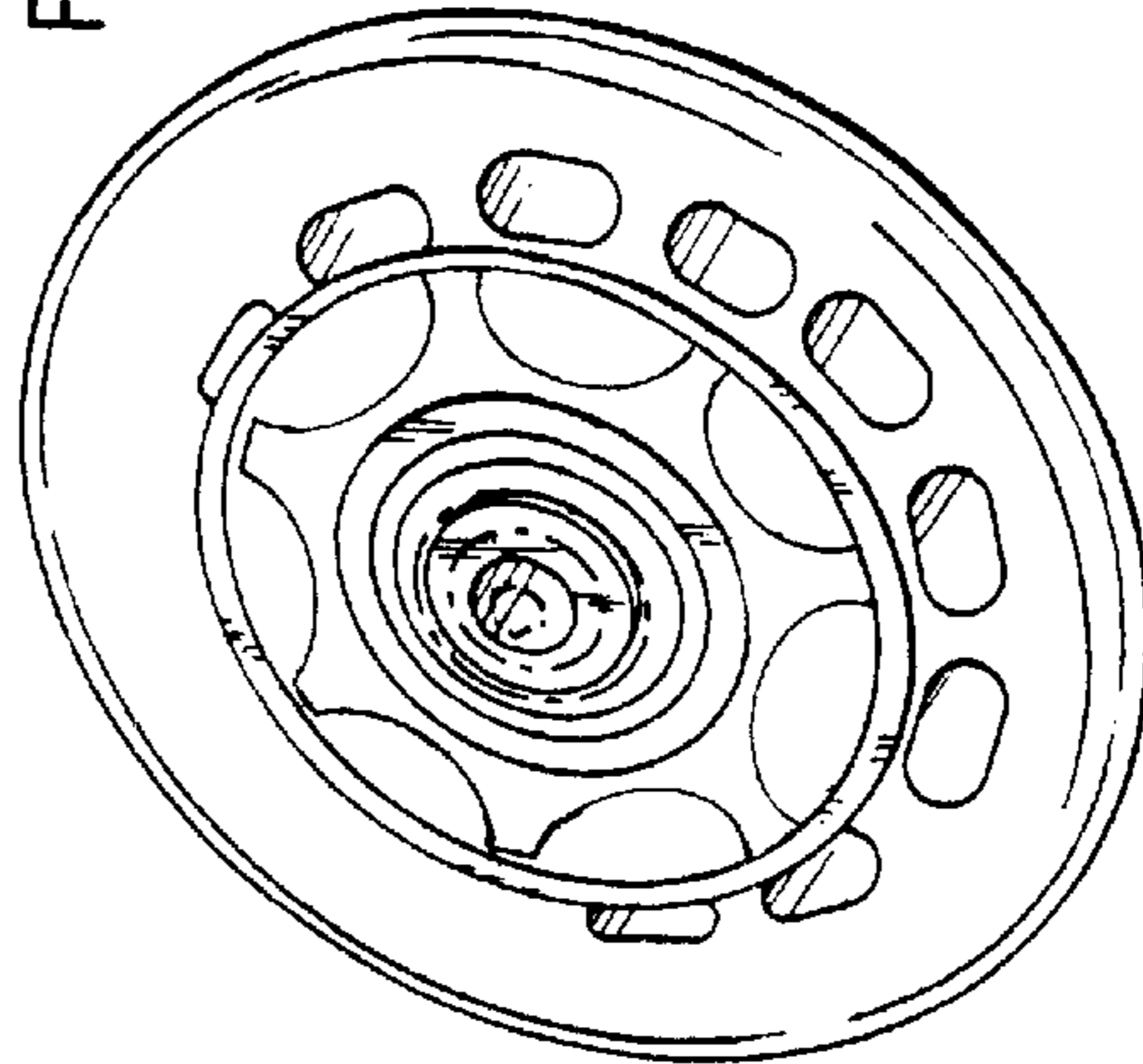

FIG-25

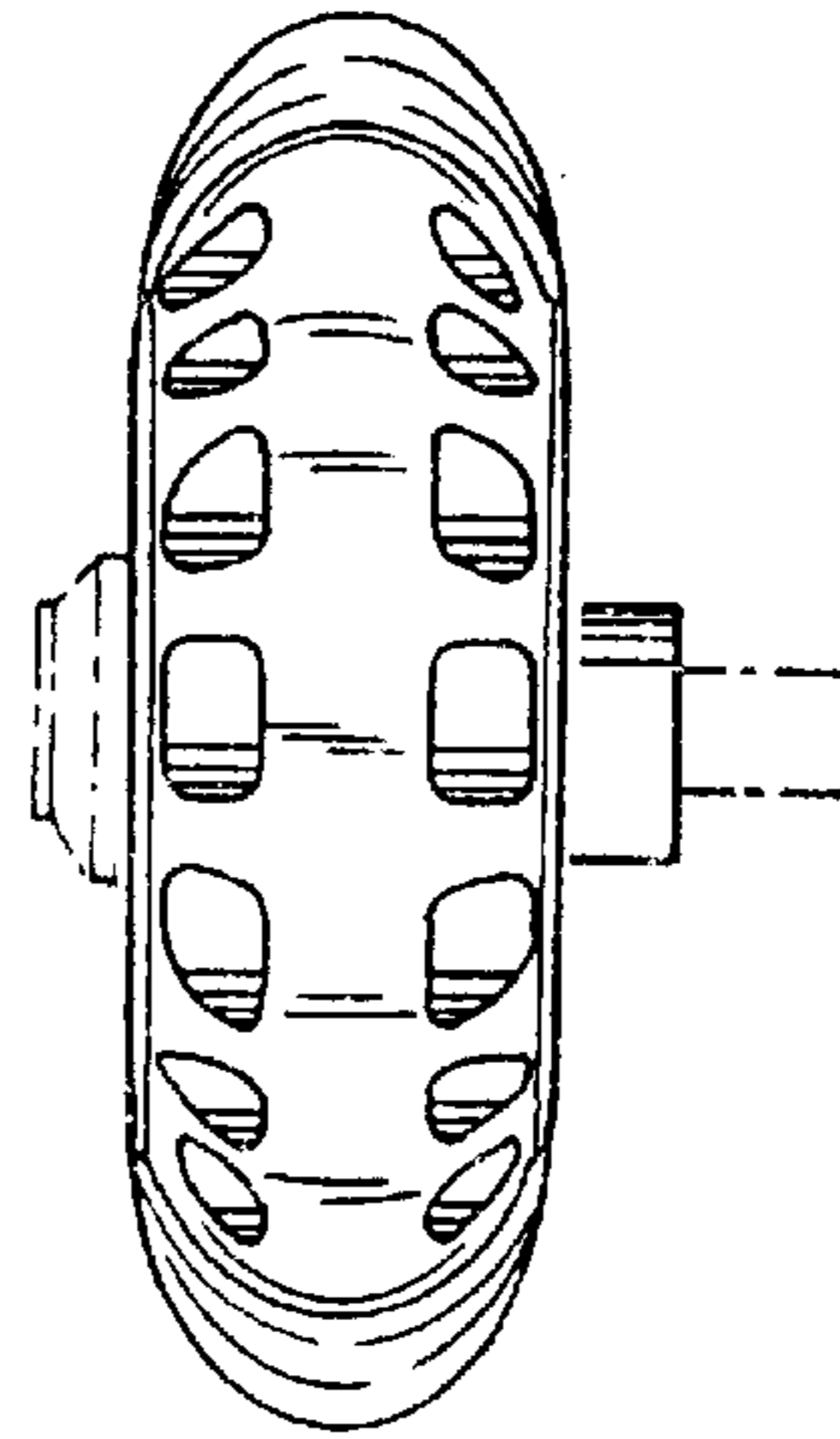

FIG-24