



US00D466095S

(12) **United States Design Patent**
Poulter et al.

(10) **Patent No.:** **US D466,095 S**

(45) **Date of Patent:** **** Nov. 26, 2002**

(54) **HOUSING OF AN ELECTRONIC EXTENDER**

(75) Inventors: **Alan R Poulter**, Bedford (GB);
Richard N Bayfield, Milton Keynes
(GB); **Paul J Moran**, Hemel
Hempstead (GB); **Quang T Tran**,
Hemel Hempstead (GB); **Sharon L**
Wiles, Bedford (GB); **David Whitfield**,
Surbiton (GB)

(73) Assignee: **3COM Corporation**, Santa Clara, CA
(US)

(**) Term: **14 Years**

(21) Appl. No.: **29/148,798**

(22) Filed: **Sep. 28, 2001**

(30) **Foreign Application Priority Data**

Apr. 20, 2001 (GB) 0109701
Apr. 20, 2001 (GB) 2101259

(51) **LOC (7) Cl.** **13-03**

(52) **U.S. Cl.** **D13/184**

(58) **Field of Search** D10/75, 78, 80,
D10/105; D13/133, 184; 73/431; 174/50,
51, 52.1; 206/702, 703, 706, 707, 710,
713, 718, 719, 722; 361/600-678, 679,
683, 685, 692, 709, 724, 730, 735, 736,
752, 763, 728; 439/76.1

(56) **References Cited**

U.S. PATENT DOCUMENTS

D264,460 S * 5/1982 Moller D13/184

D311,520 S * 10/1990 Serio, Jr. D13/184
D368,429 S * 4/1996 Serio, Jr. D9/431
5,949,640 A * 9/1999 Cameron et al. 361/600
D421,598 S * 3/2000 Berusha et al. D13/184
6,164,920 A * 12/2000 Nazarian et al. 417/4
6,322,375 B1 * 11/2001 Cole et al. 439/76.1

* cited by examiner

Primary Examiner—Ted Shooman

Assistant Examiner—Selina Sikder

(74) *Attorney, Agent, or Firm*—Nixon & Vanderhye

(57) **CLAIM**

The ornamental design for a housing of an electronic extender, as shown in the Figures.

DESCRIPTION

FIG. 1 is a front perspective view of the housing of an electronic extender, showing the front, top and one side of the housing;

FIG. 2 is a perspective rear view of the housing, showing the top, rear and a said one side of the housing;

FIG. 3 is a perspective view from underneath of the housing, showing the front, the said one side and the bottom side of the housing;

FIG. 4 is a plan view from above of the housing; and,

FIG. 5 is a side view showing a second side of the housing.

1 Claim, 3 Drawing Sheets

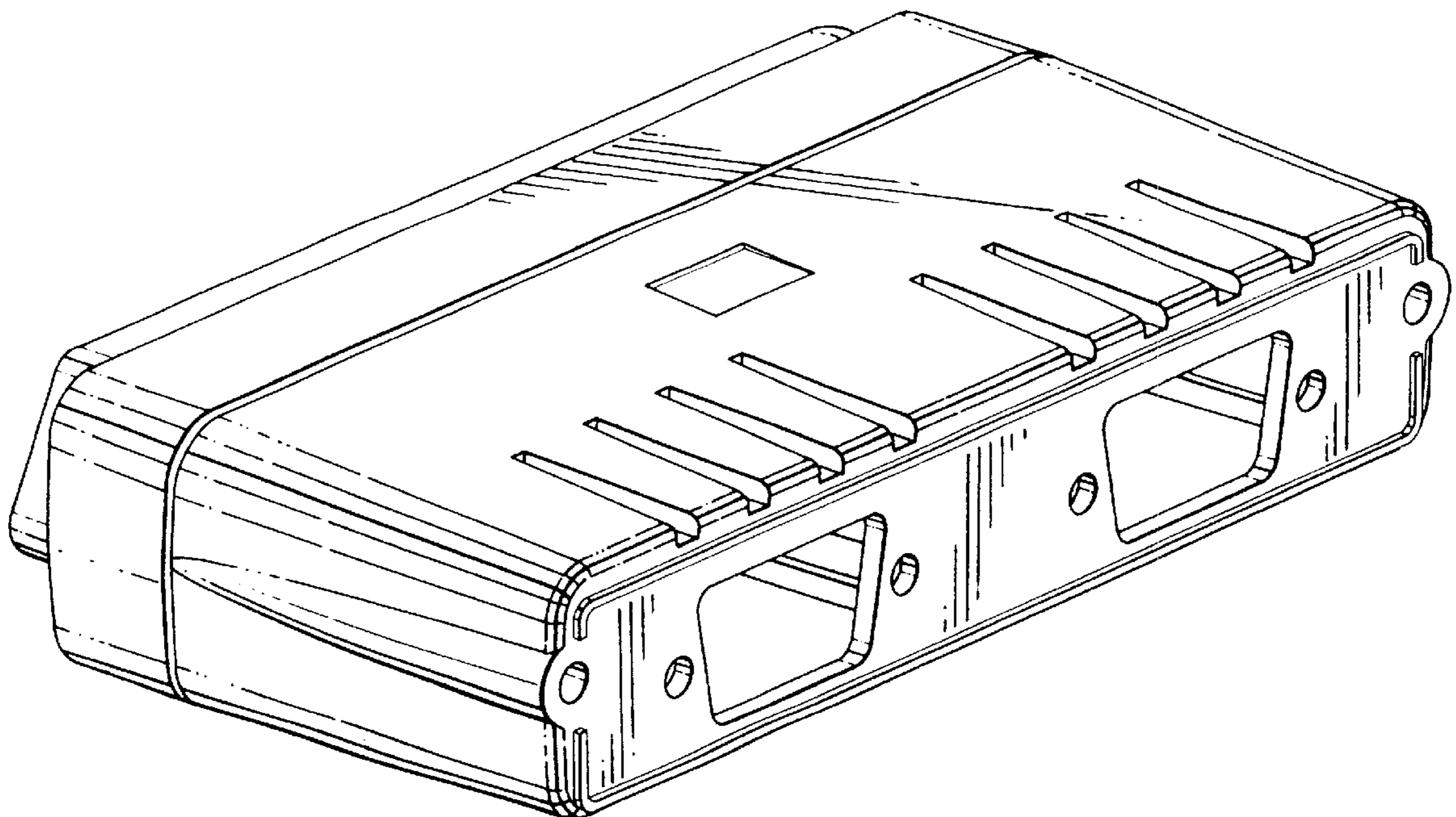

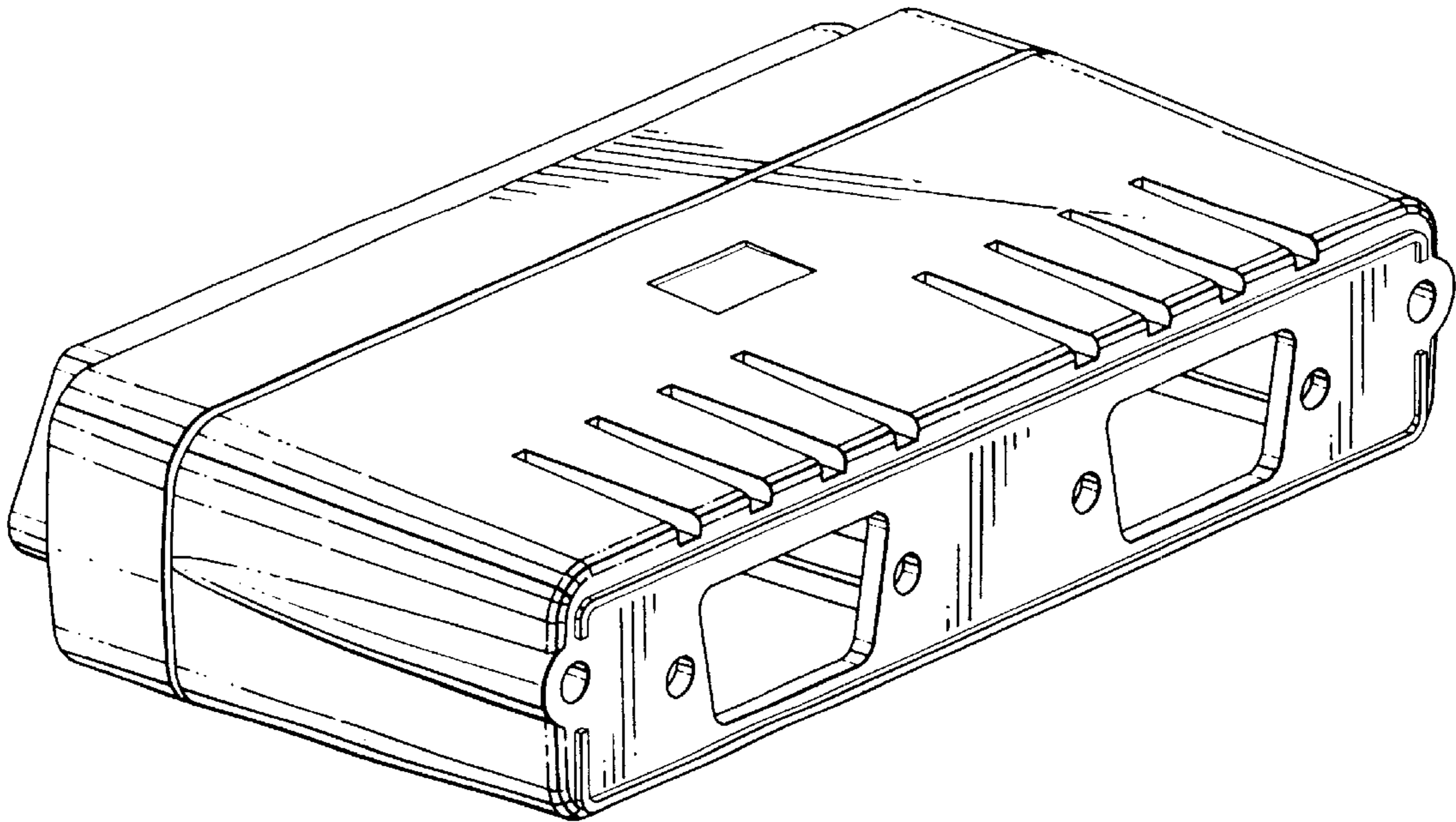

FIG. 1

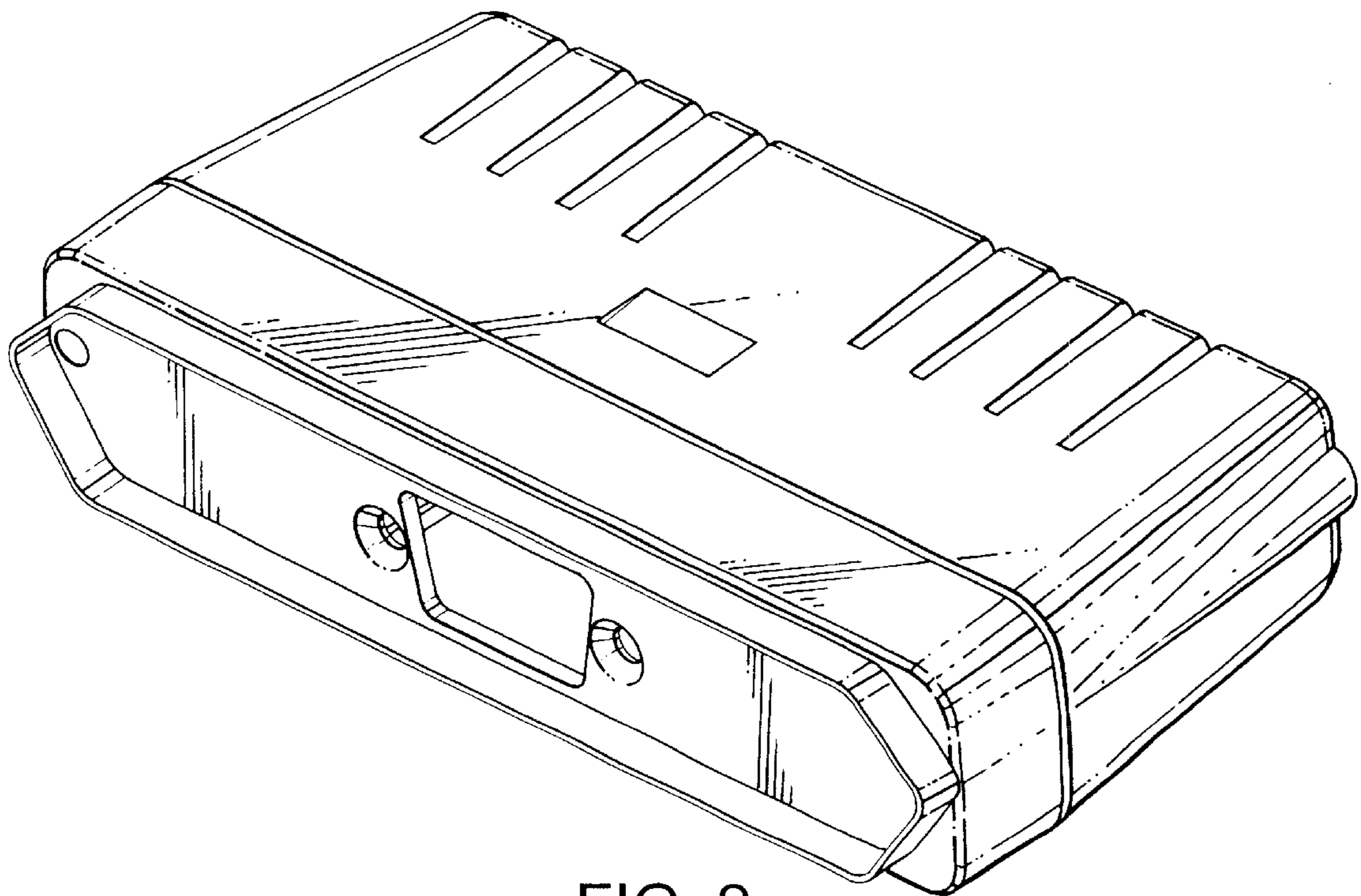

FIG. 2

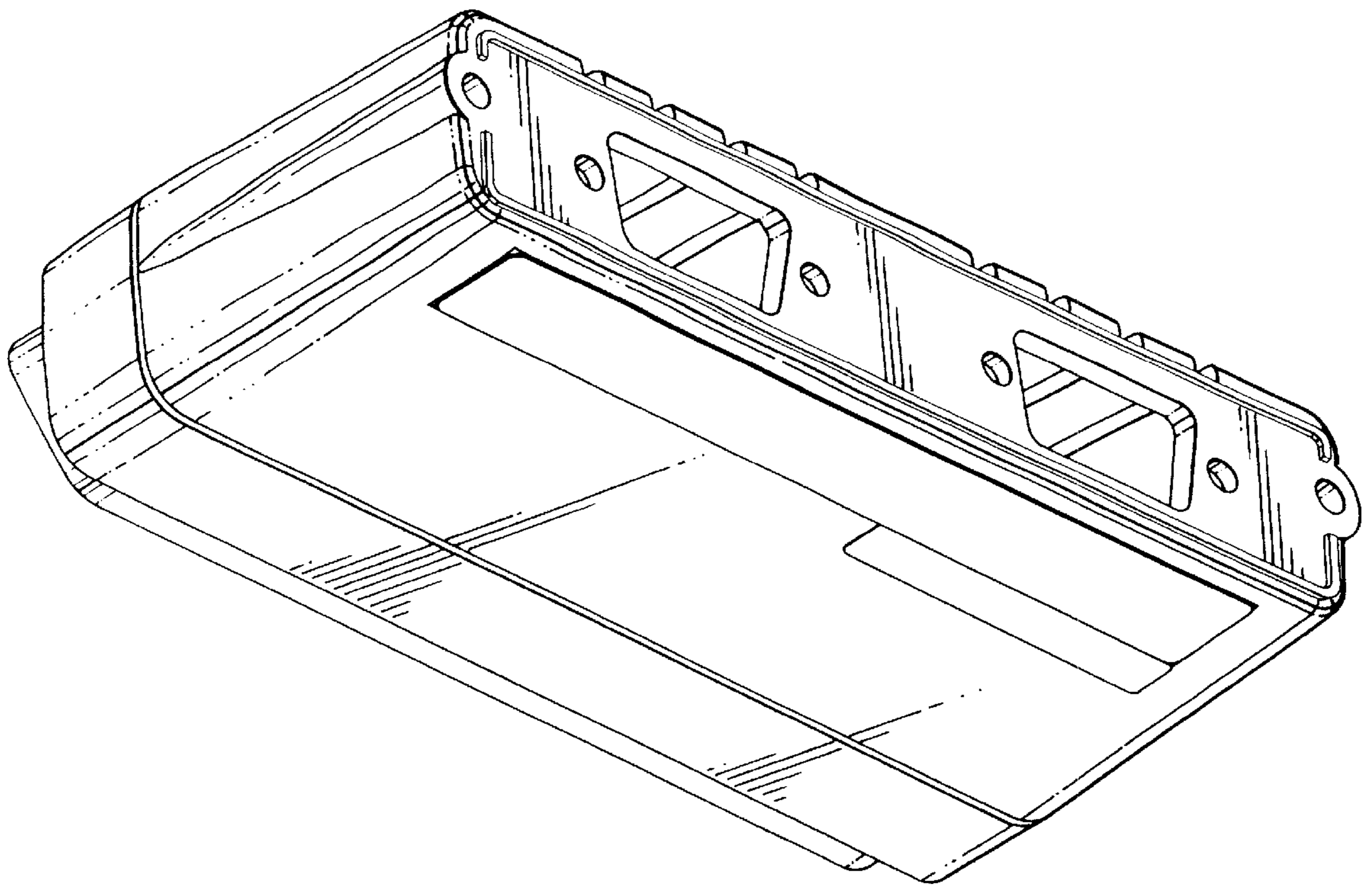

FIG. 3

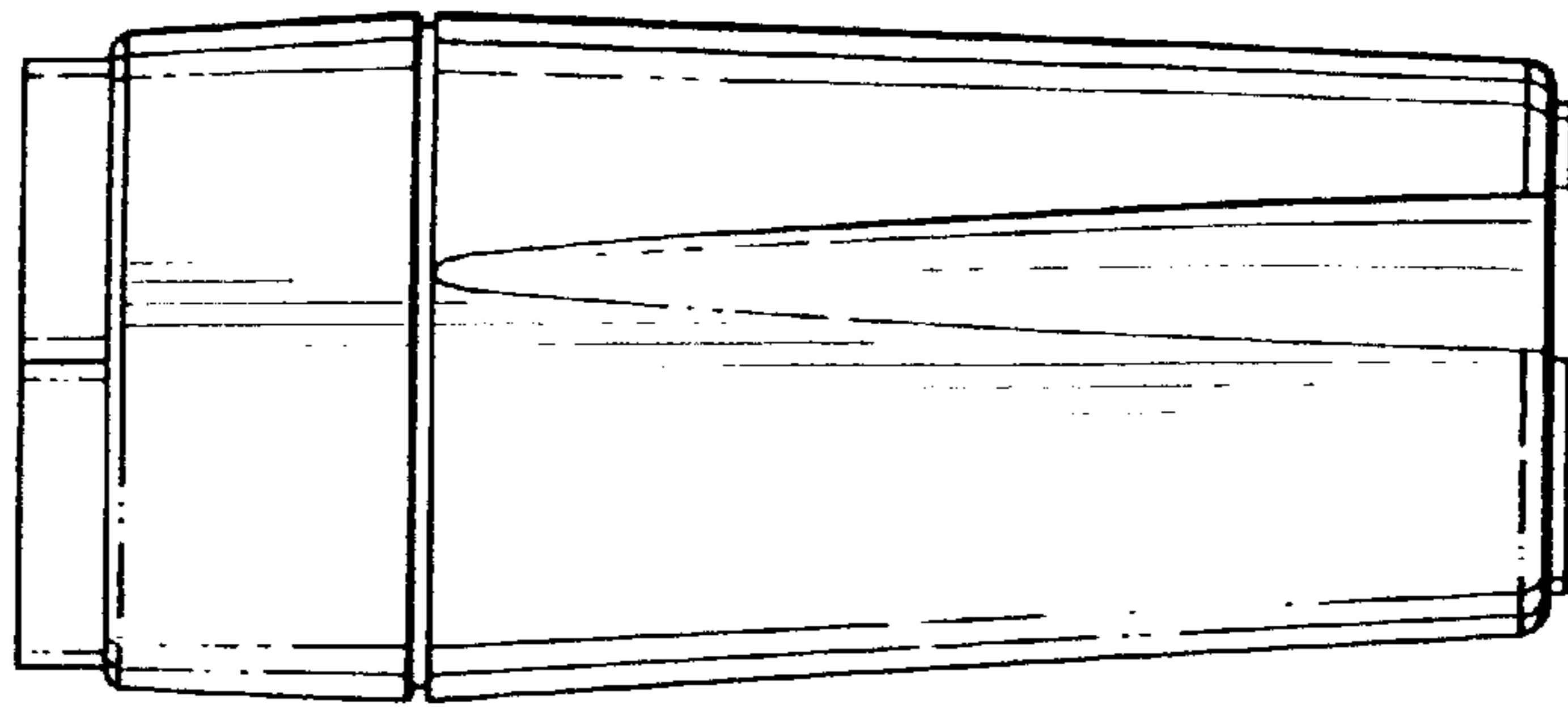

FIG. 5

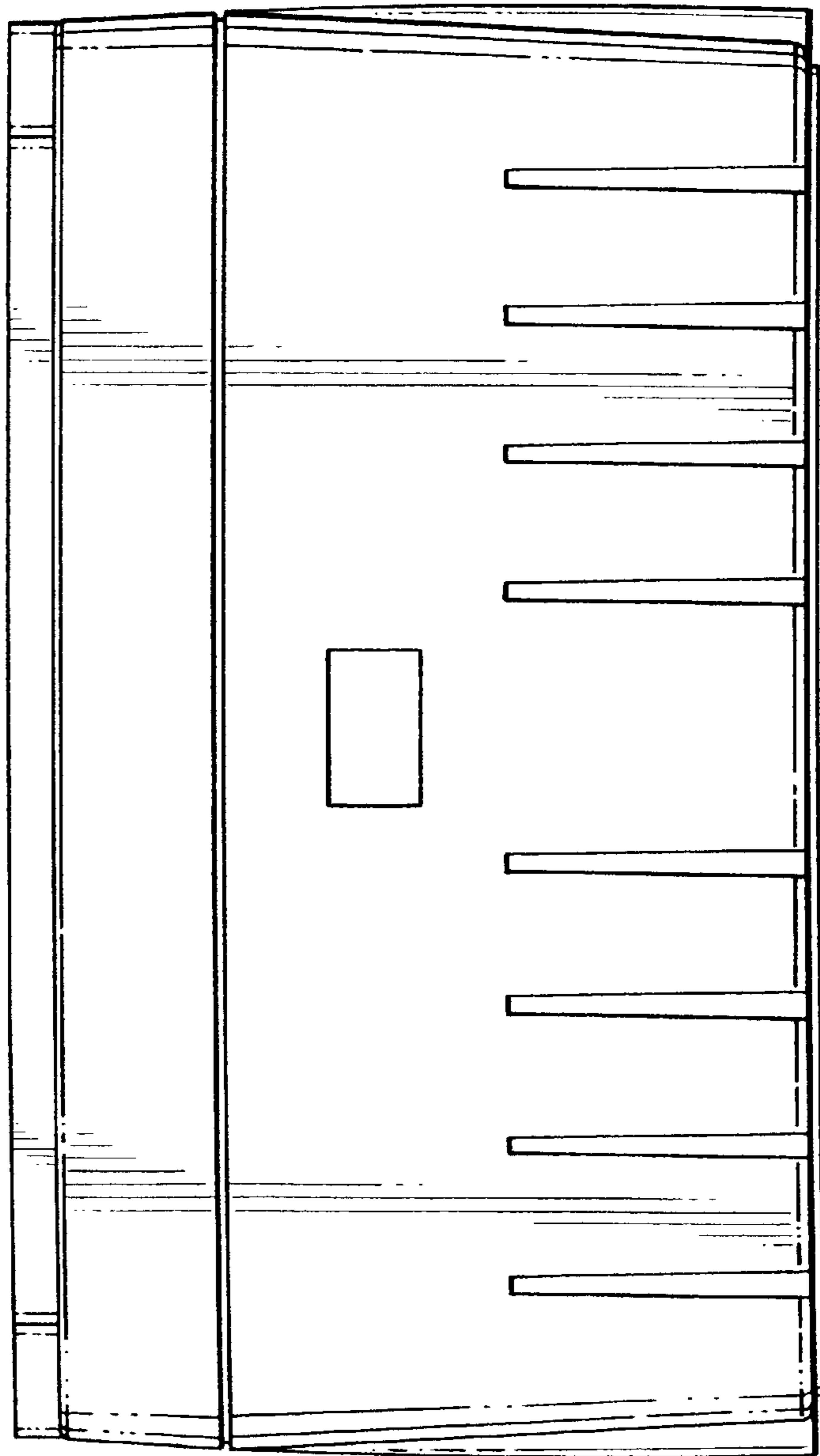

FIG. 4