



US00D465814S

(12) **United States Design Patent**
Koveleski

(10) **Patent No.:** **US D465,814 S**

(45) **Date of Patent:** **** Nov. 19, 2002**

(54) **JUVENILE RIDING CAR**

(75) Inventor: **Anthony M. Koveleski**, 1212 W. Grove St., Clarks Summit, PA (US) 18411

(73) Assignee: **Anthony M. Koveleski**, Clarks Summit, PA (US)

(**) Term: **14 Years**

(21) Appl. No.: **29/151,489**

(22) Filed: **Oct. 23, 2001**

(51) **LOC (7) Cl.** **21-01**

(52) **U.S. Cl.** **D21/433; D21/550; D21/551**

(58) **Field of Search** D21/419-435,
D21/533, 548-551; D12/108, 83, 87, 88;
446/160, 447, 428, 456, 465, 470; 280/1.13,
87.01, 87.021, 828, 87.041

(56) **References Cited**

U.S. PATENT DOCUMENTS

D255,810 S	*	7/1980	Bretschger	D21/550
4,335,899 A	*	6/1982	Hiscock		
D311,038 S	*	10/1990	Head	D21/550
D359,082 S	*	6/1995	Aker	D21/550
D368,743 S	*	4/1996	Amburgey	D12/108
D432,186 S	*	10/2000	Kuo	D21/433

OTHER PUBLICATIONS

Auto Sports Association Ltd., Kidracer Promotional Circular, 1995, pp. 1-2.

* cited by examiner

Primary Examiner—Raphael Barkai

(74) *Attorney, Agent, or Firm*—Cesari and McKenna, LLP; William A. Loginov, Esq.

(57) **CLAIM**

The ornamental design for a juvenile riding car, substantially as shown and described.

DESCRIPTION

FIG. 1 is an isometric view from the front of a juvenile riding car incorporating the design;

FIG. 2 is a right-side view thereof;

FIG. 3 is a left-side view thereof;

FIG. 4 is a top plan view thereof;

FIG. 5 is a bottom plan view thereof;

FIG. 6 is a front view thereof;

FIG. 7 is a back view thereof;

FIG. 8 is a front view of a steering wheel of the juvenile riding car according to an alternate embodiment; and,

FIG. 9 is a right side view of the steering wheel of FIG. 8, the left side view being an identical mirror image of FIG. 9.

The wheel is shown separately in FIGS. 8 and 9 for ease of illustration only.

1 Claim, 5 Drawing Sheets

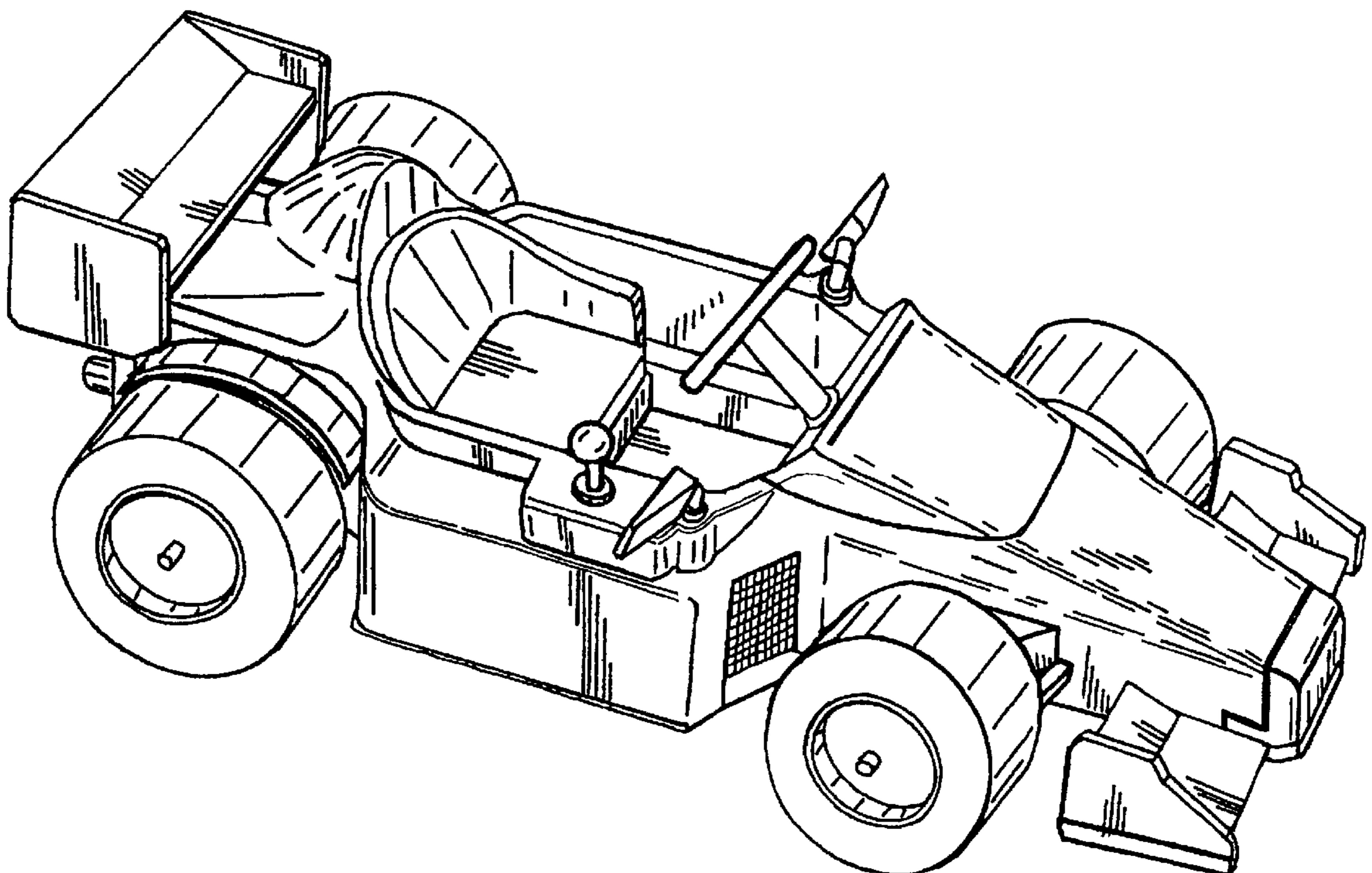

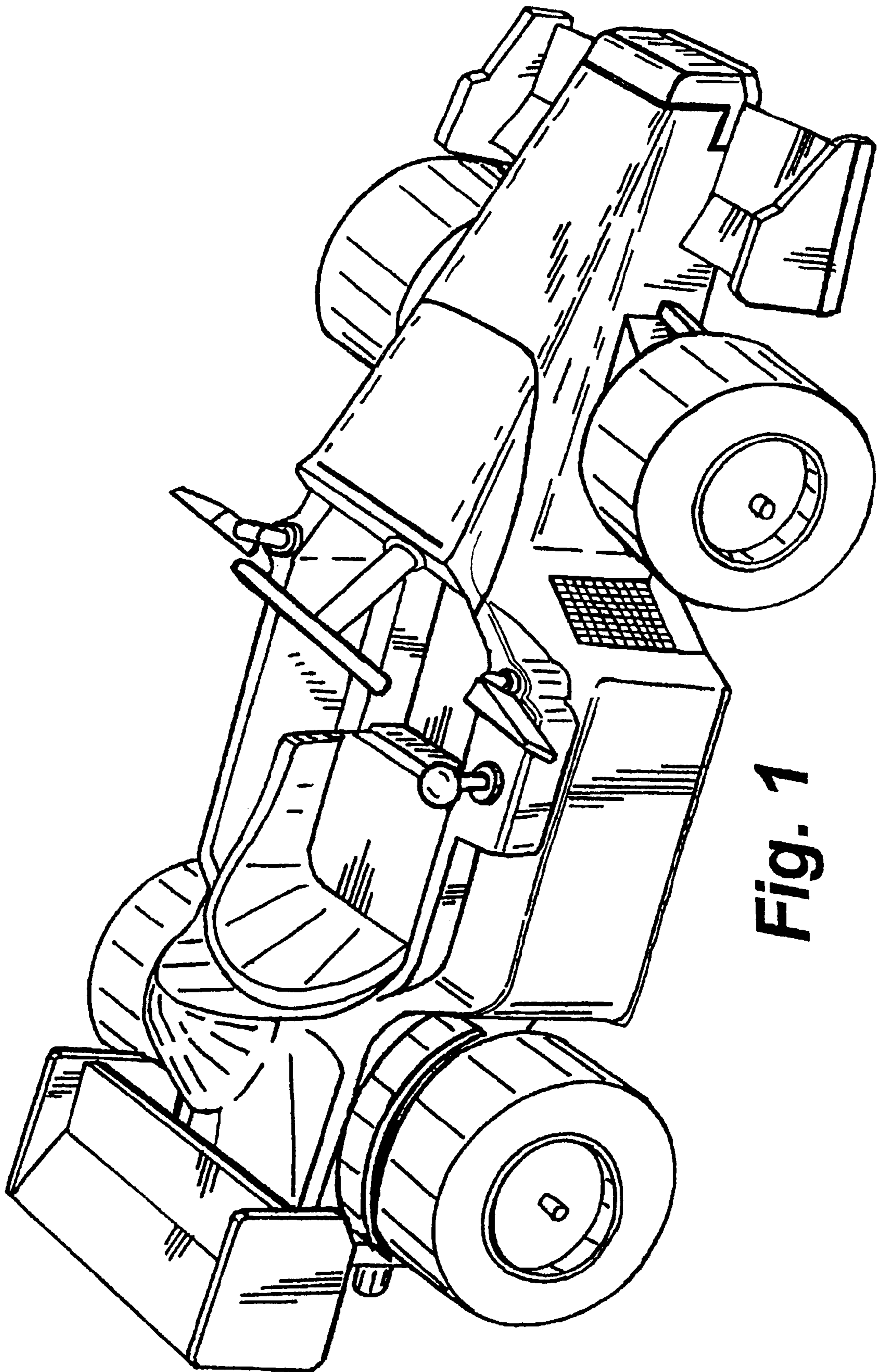

Fig. 1

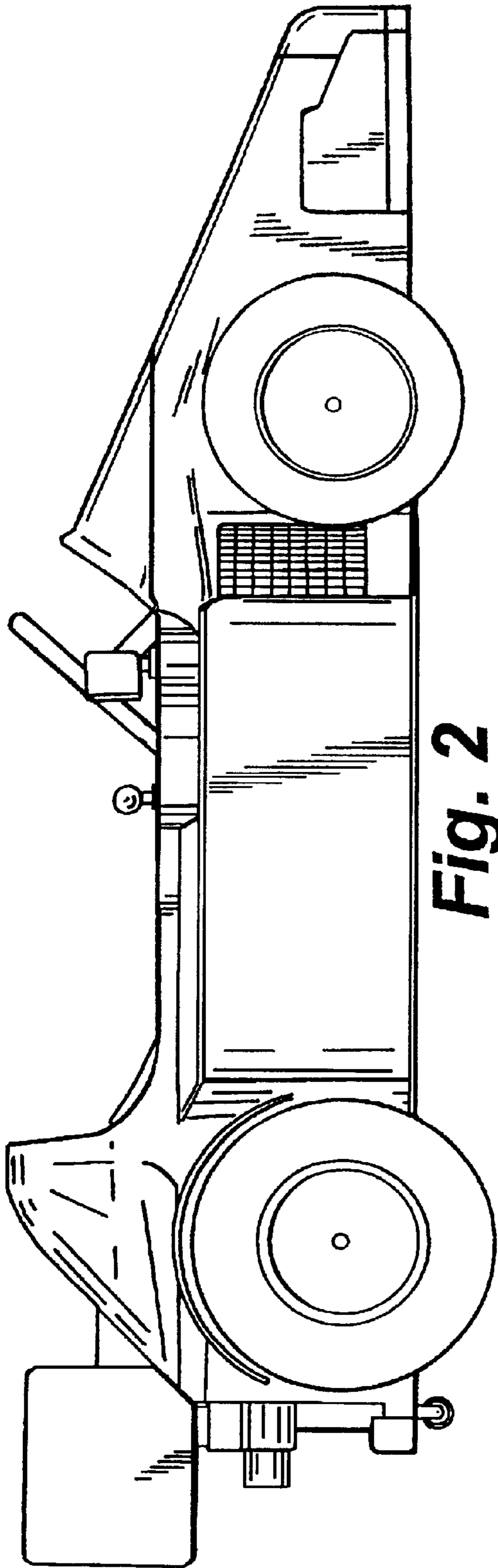

Fig. 2

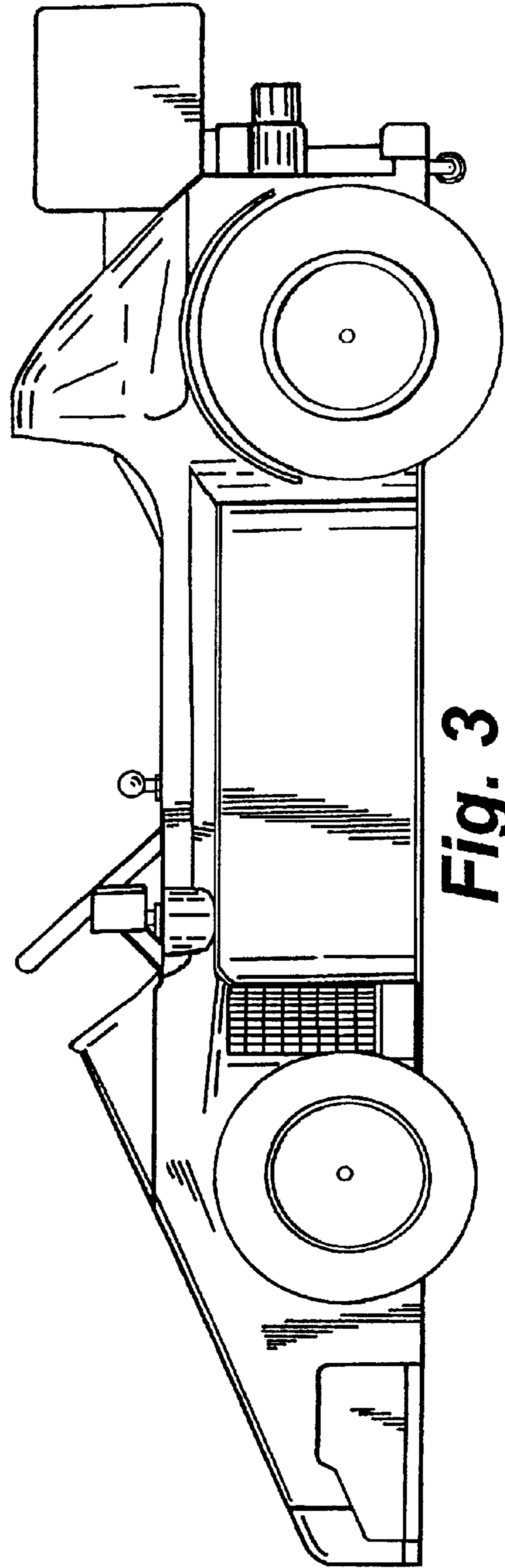

Fig. 3

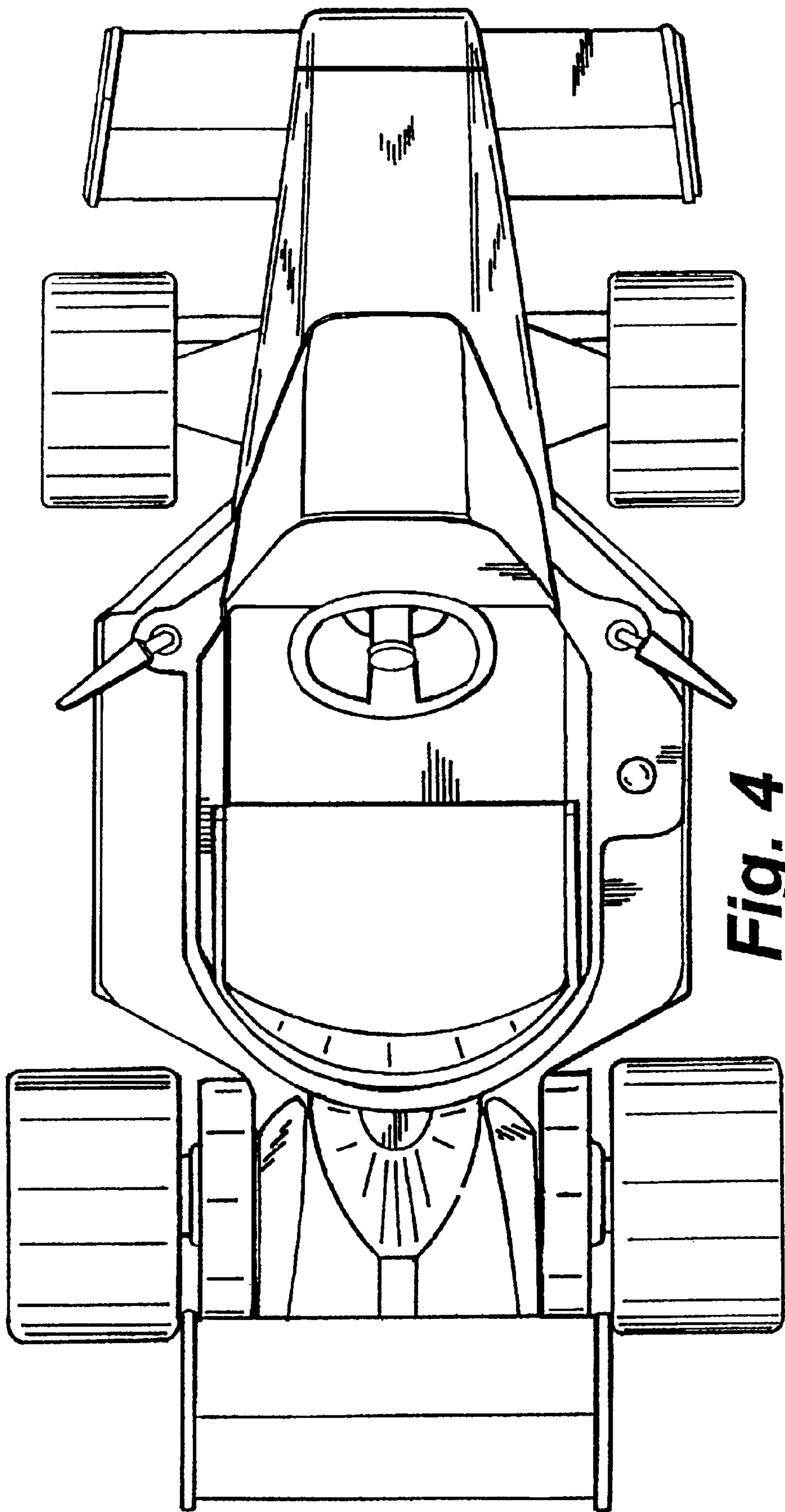

Fig. 4

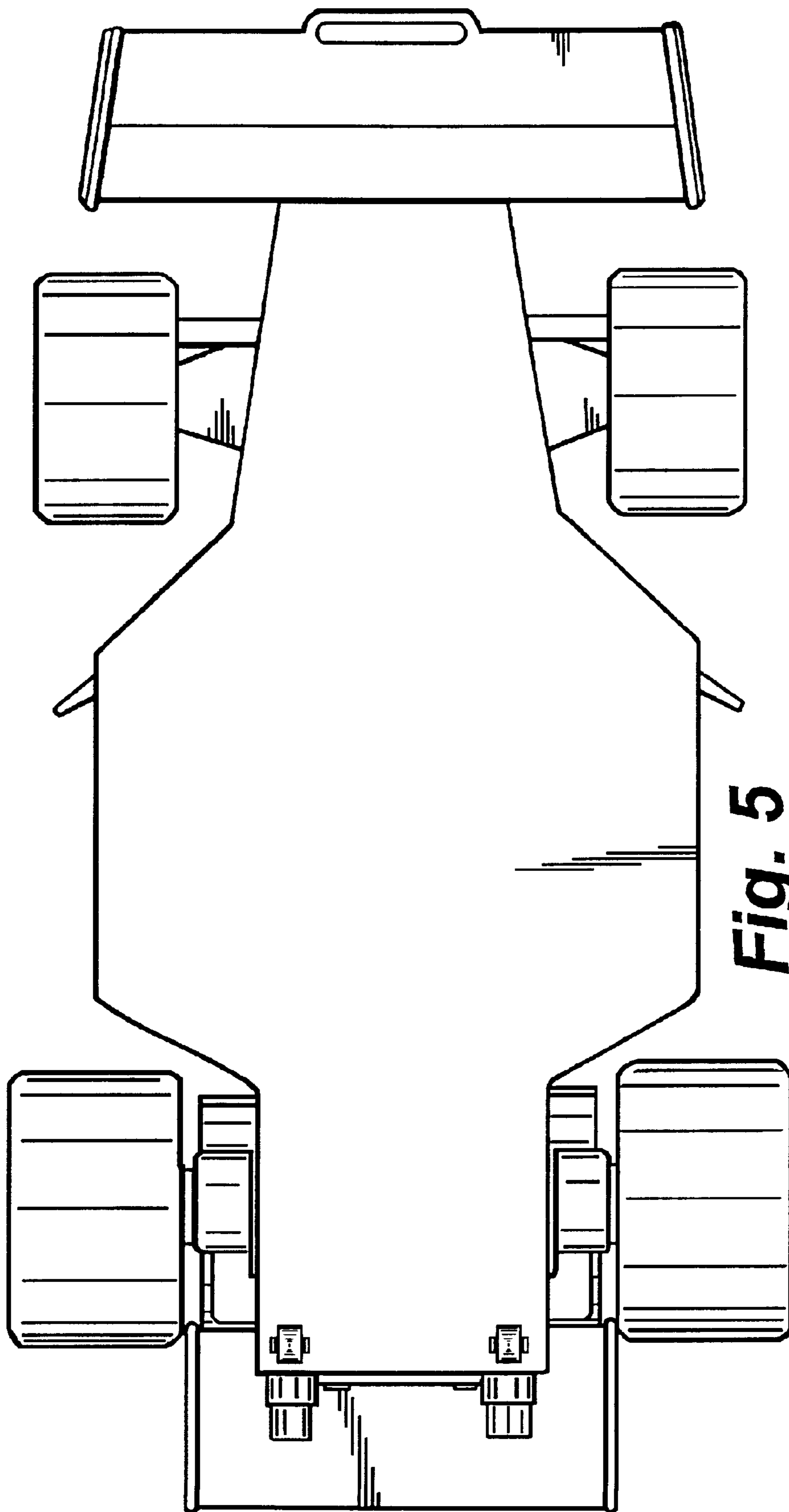

Fig. 5

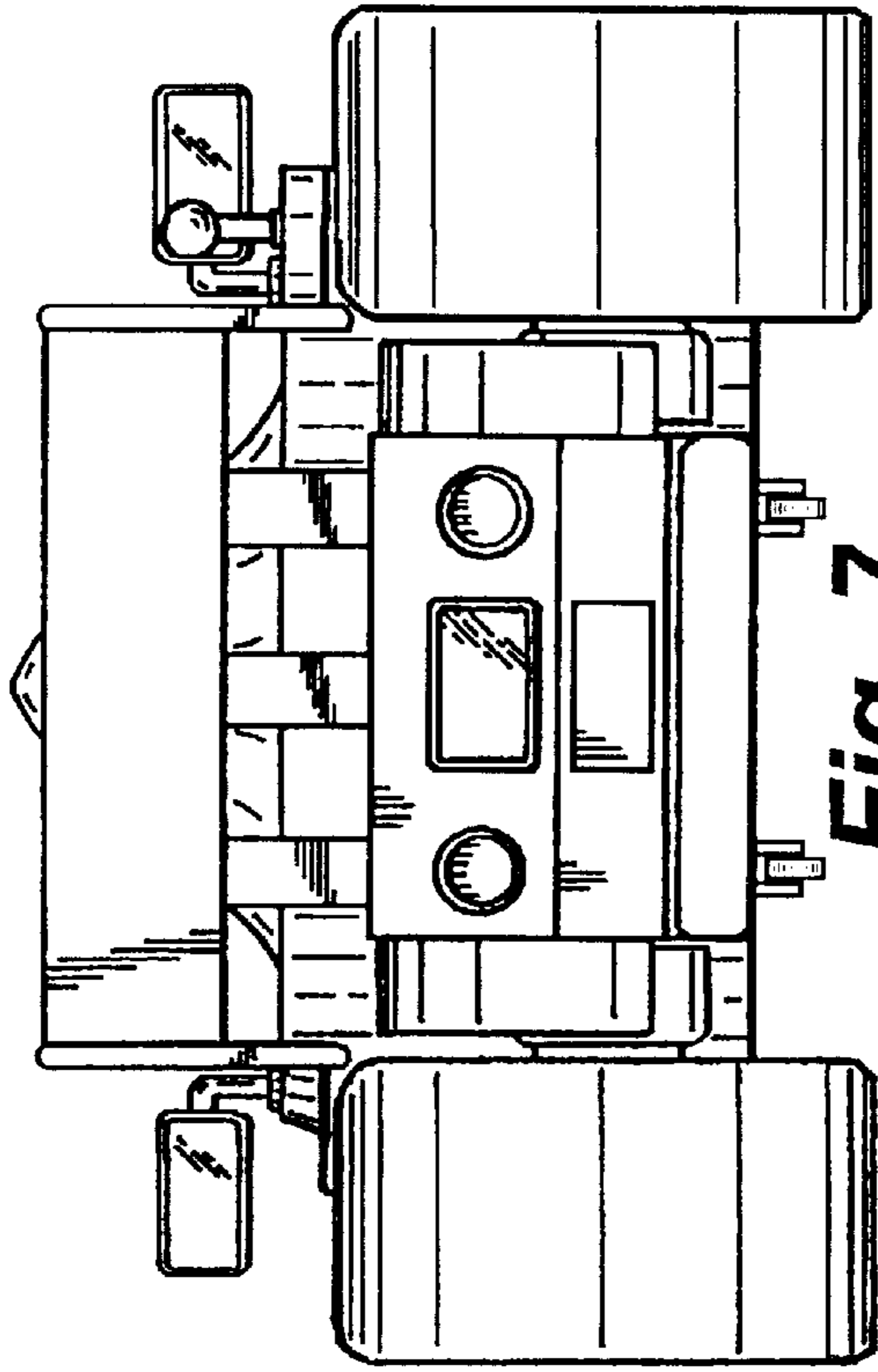

Fig. 7

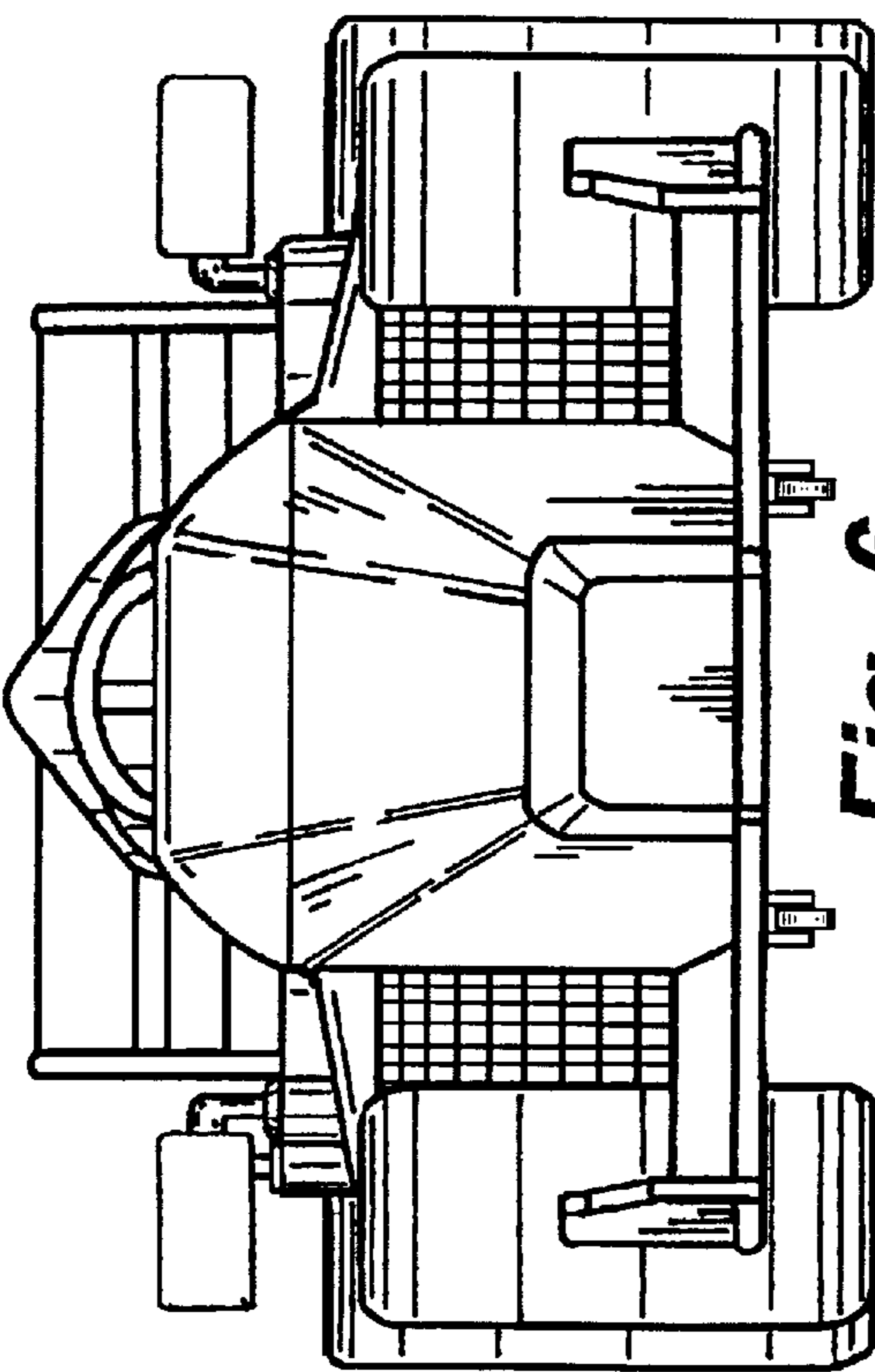

Fig. 6

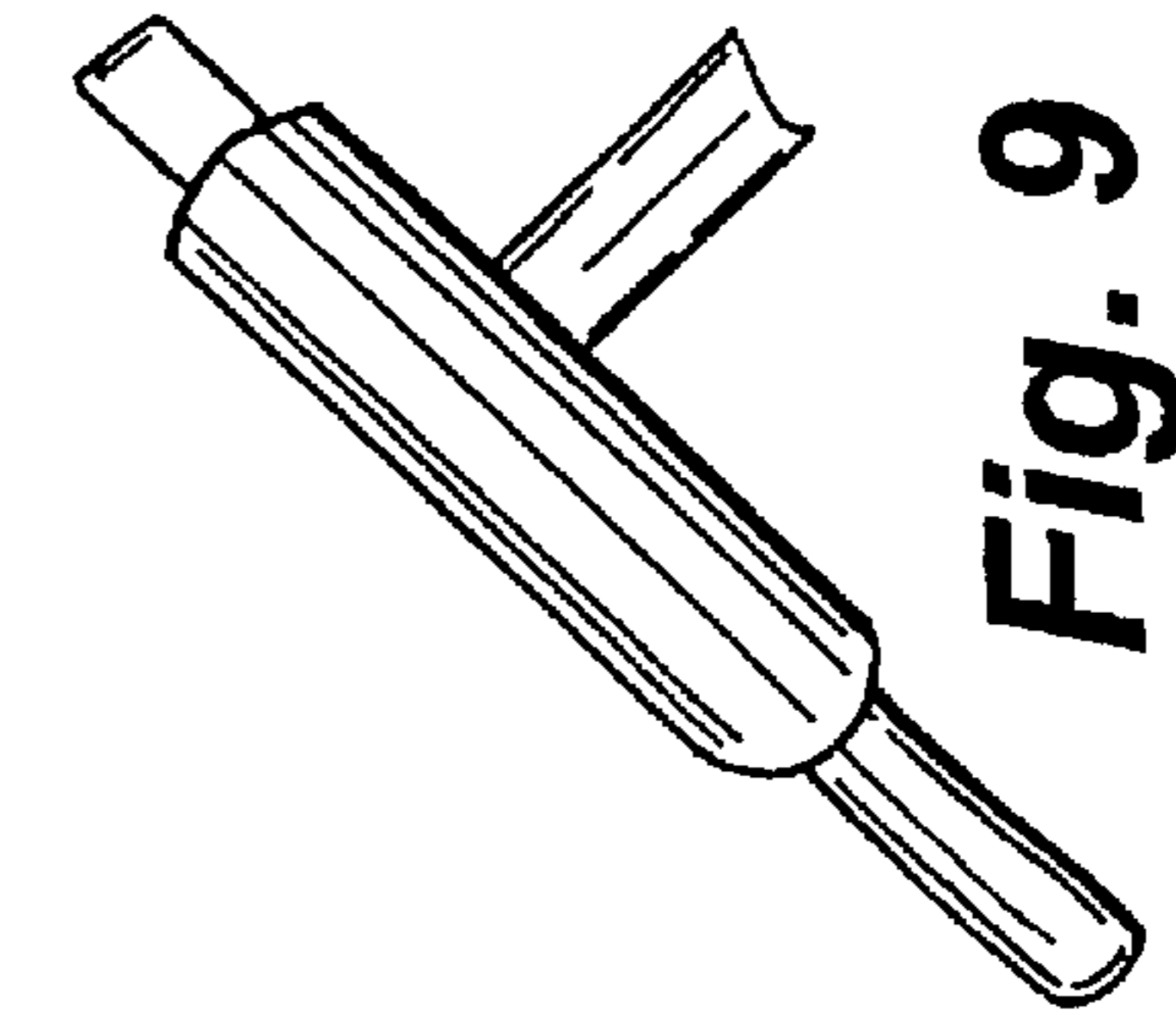

Fig. 9

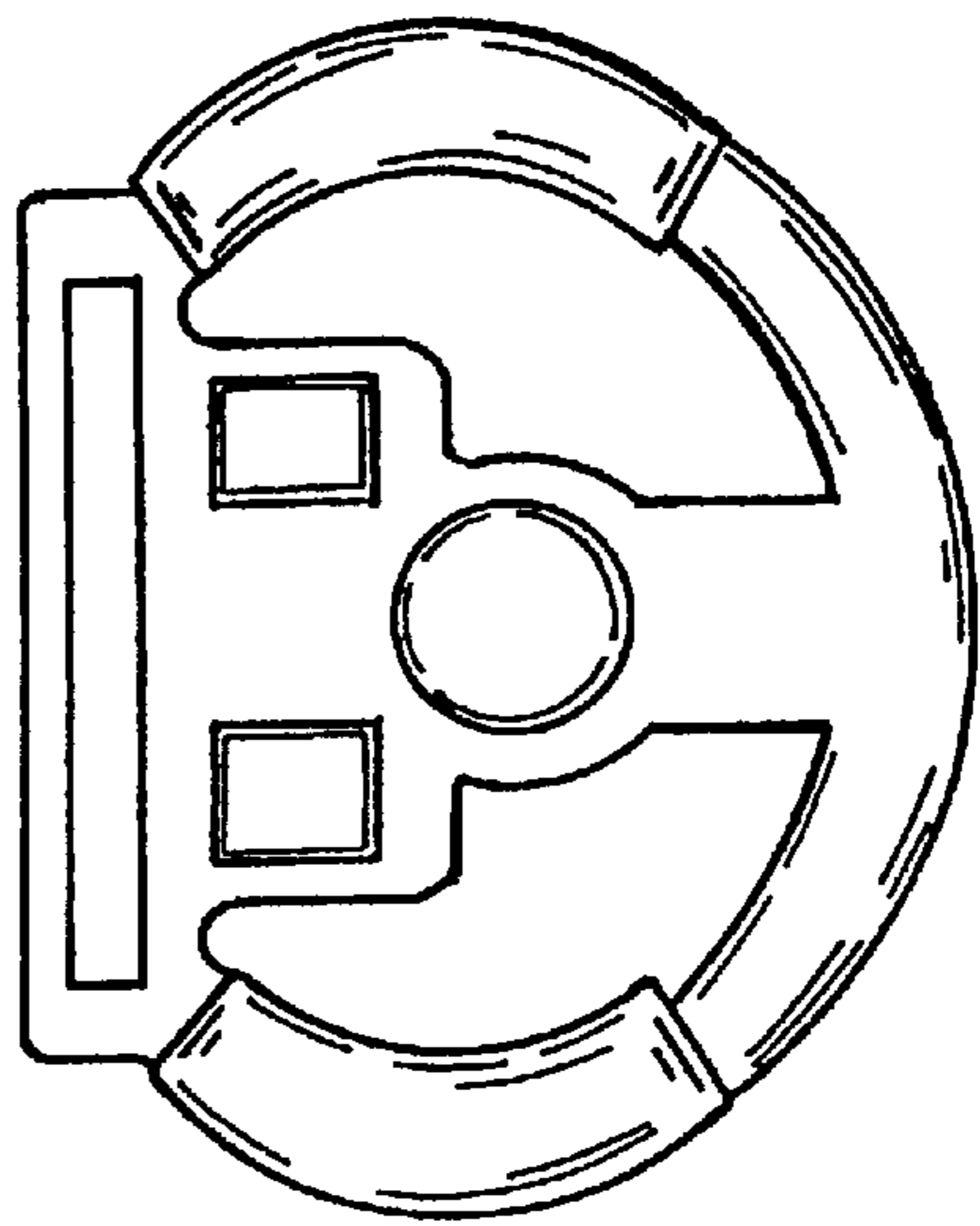

Fig. 8