



US00D465812S

(12) **United States Design Patent**
Lee

(10) **Patent No.:** **US D465,812 S**

(45) **Date of Patent:** **** Nov. 19, 2002**

(54) **STAND FOR OUTDOOR ADVERTISING**

(75) **Inventor:** **Kwang-Young Lee, 946**
Mansung-Dong, Duckjin-Ku, Jeongju,
Jeollabuk-Do, 561-350 (KR)

(73) **Assignee:** **Kwang-Young Lee, Jeollabuk-Do**
(KR)

(**) **Term:** **14 Years**

(21) **Appl. No.:** **29/148,594**

(22) **Filed:** **Sep. 25, 2001**

(51) **LOC (7) Cl.** **20-99**

(52) **U.S. Cl.** **D20/99**

(58) **Field of Search** D11/96; D20/10,
D20/12, 19, 21, 29, 34, 41, 99; D25/9;
D99/25; 324/240; 428/542.4

(56) **References Cited**

U.S. PATENT DOCUMENTS

- D7,807 S * 10/1874 King D99/25
- D75,862 S * 7/1928 Nelson D25/9
- D149,387 S * 4/1948 Stengaard D20/10

- 2,608,779 A * 9/1952 Joy 40/431
- D173,126 S * 9/1954 Reilly, Sr. D99/25
- D197,456 S * 2/1964 Harimer D20/29
- D199,349 S * 10/1964 Chenault D20/10
- D202,760 S * 11/1965 Speaect D20/41
- 6,265,871 B1 * 7/2001 Logue et al. 324/240

* cited by examiner

Primary Examiner—Robert M. Spear

(74) *Attorney, Agent, or Firm*—Staas & Halsey LLP

(57) **CLAIM**

The ornamental design for a stand for outdoor advertising, as shown.

DESCRIPTION

FIG. 1 is a perspective view of my new stand for outdoor advertising design;
 FIG. 2 is a front view thereof;
 FIG. 3 is a rear view thereof;
 FIG. 4 is a top view thereof;
 FIG. 5 is a bottom view thereof;
 FIG. 6 is a left side view thereof; and,
 FIG. 7 is a right side view thereof.

1 Claim, 7 Drawing Sheets

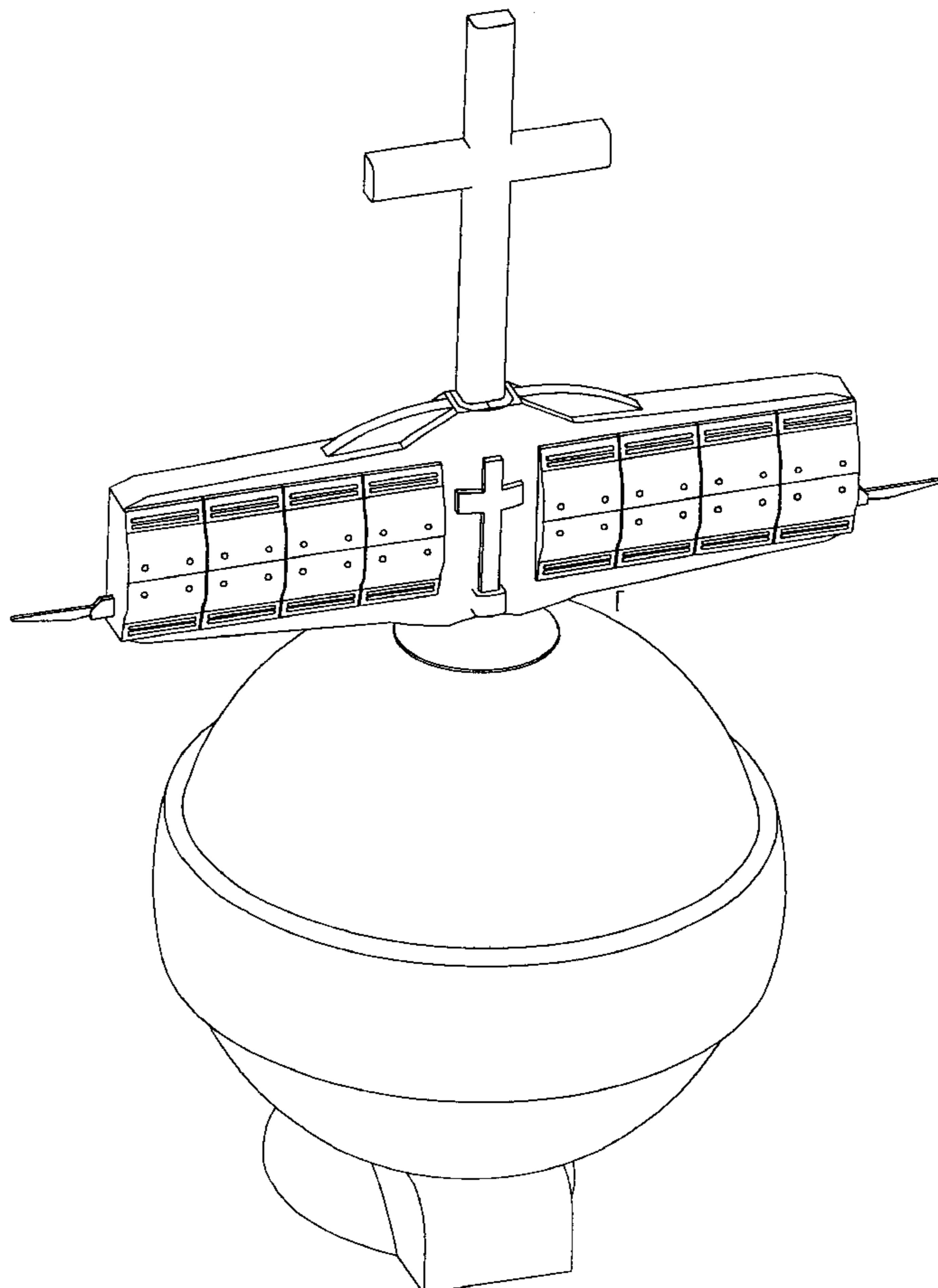

FIG. 1

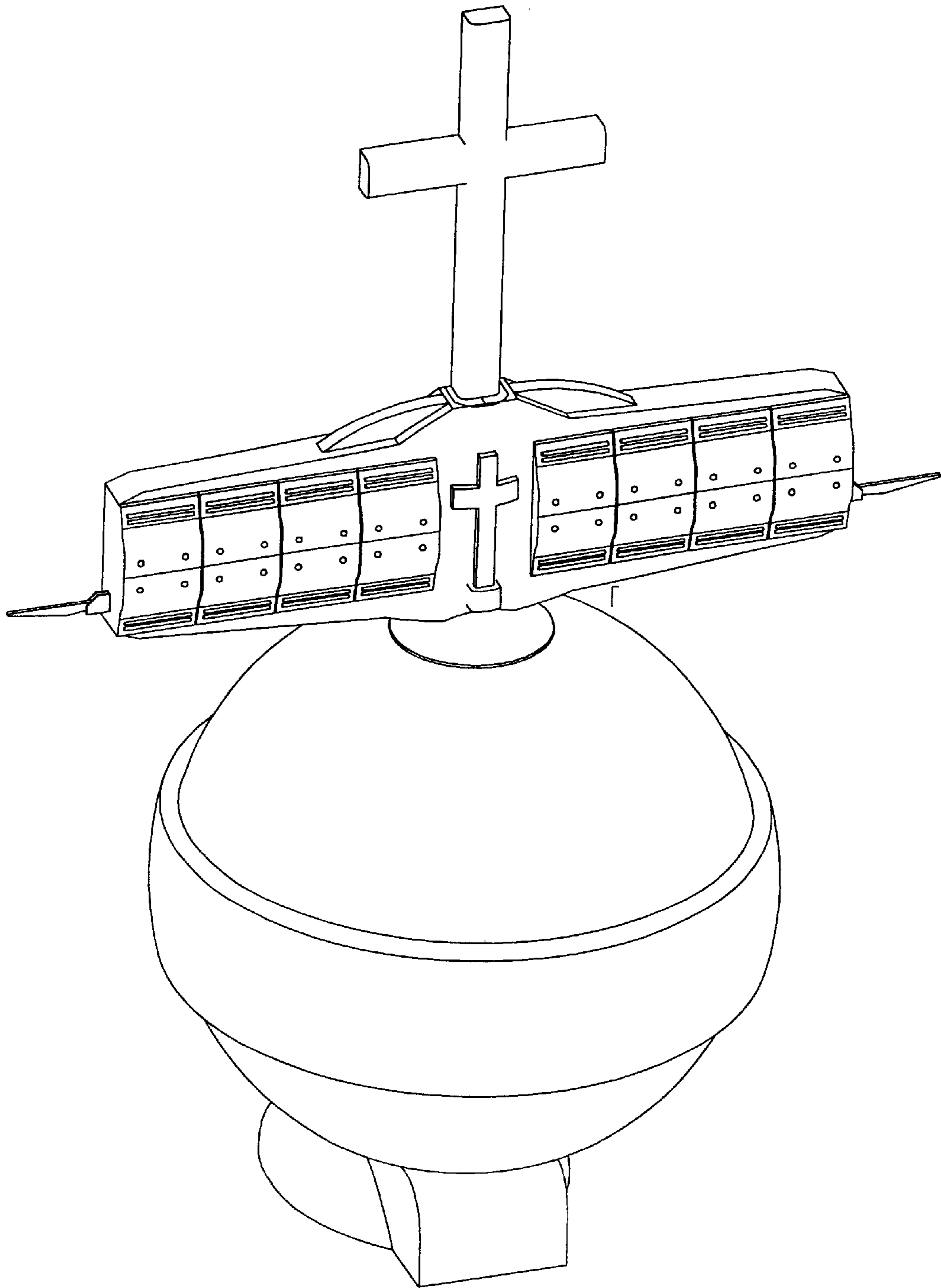

FIG. 2

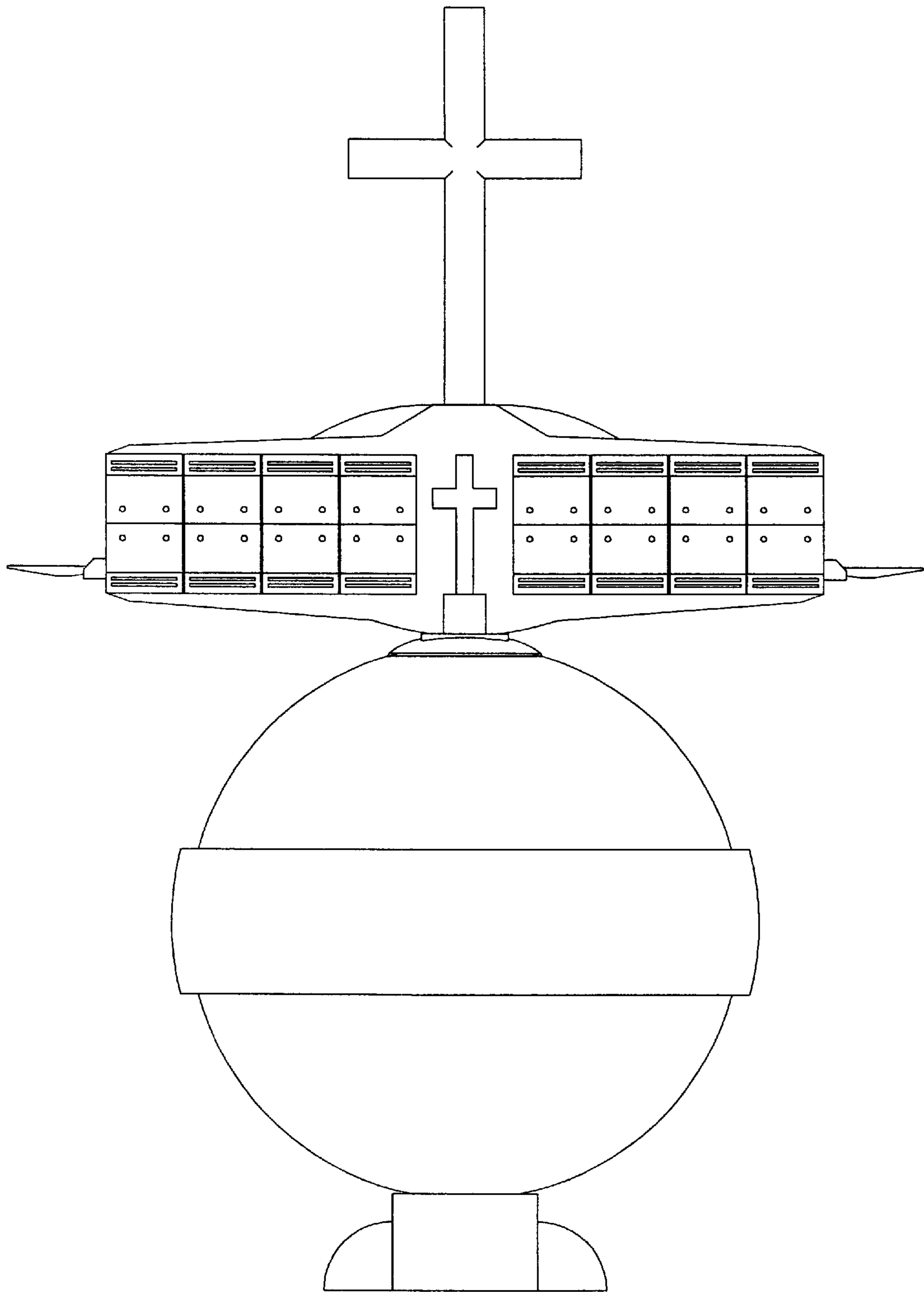

FIG. 3

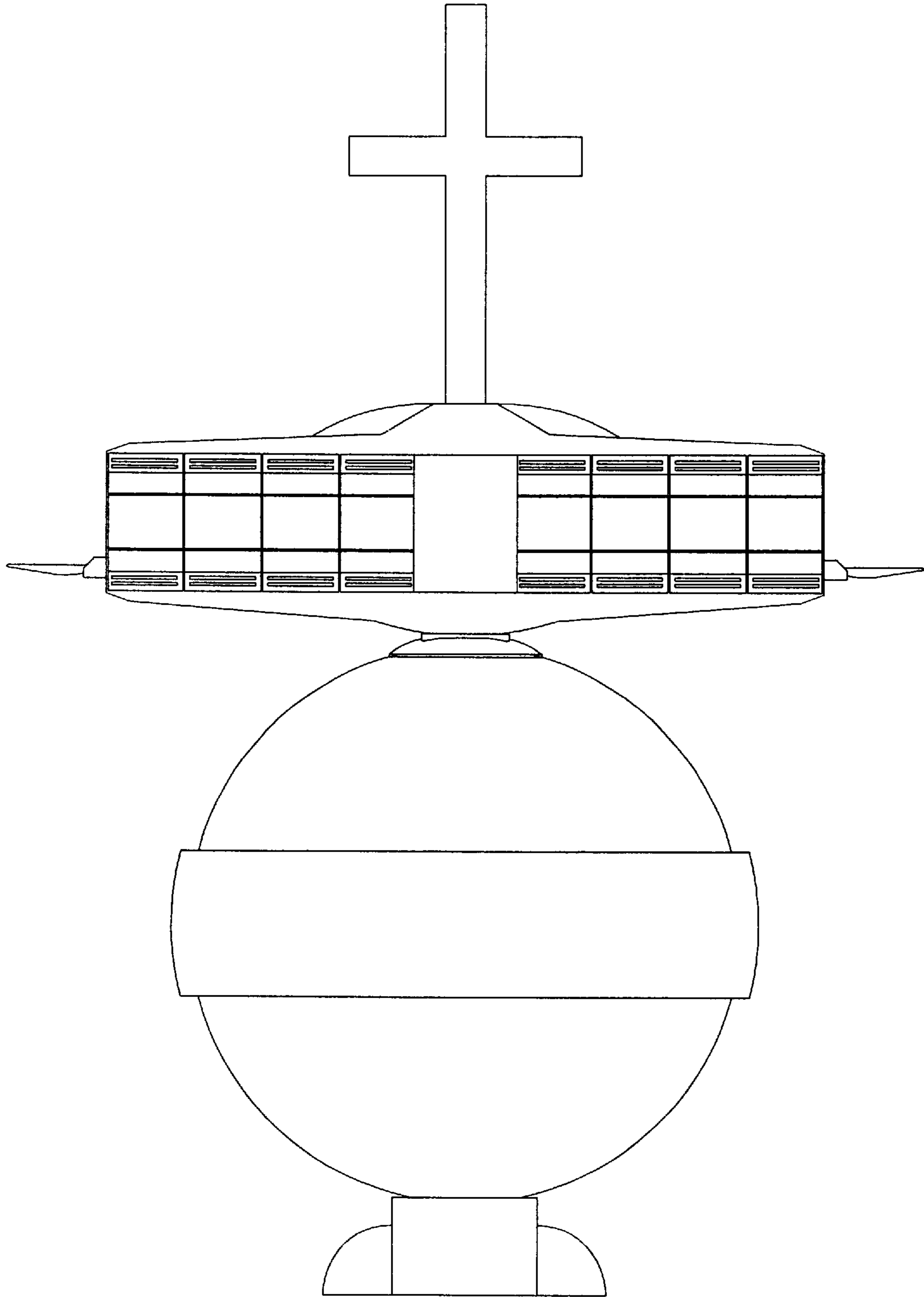

FIG. 4

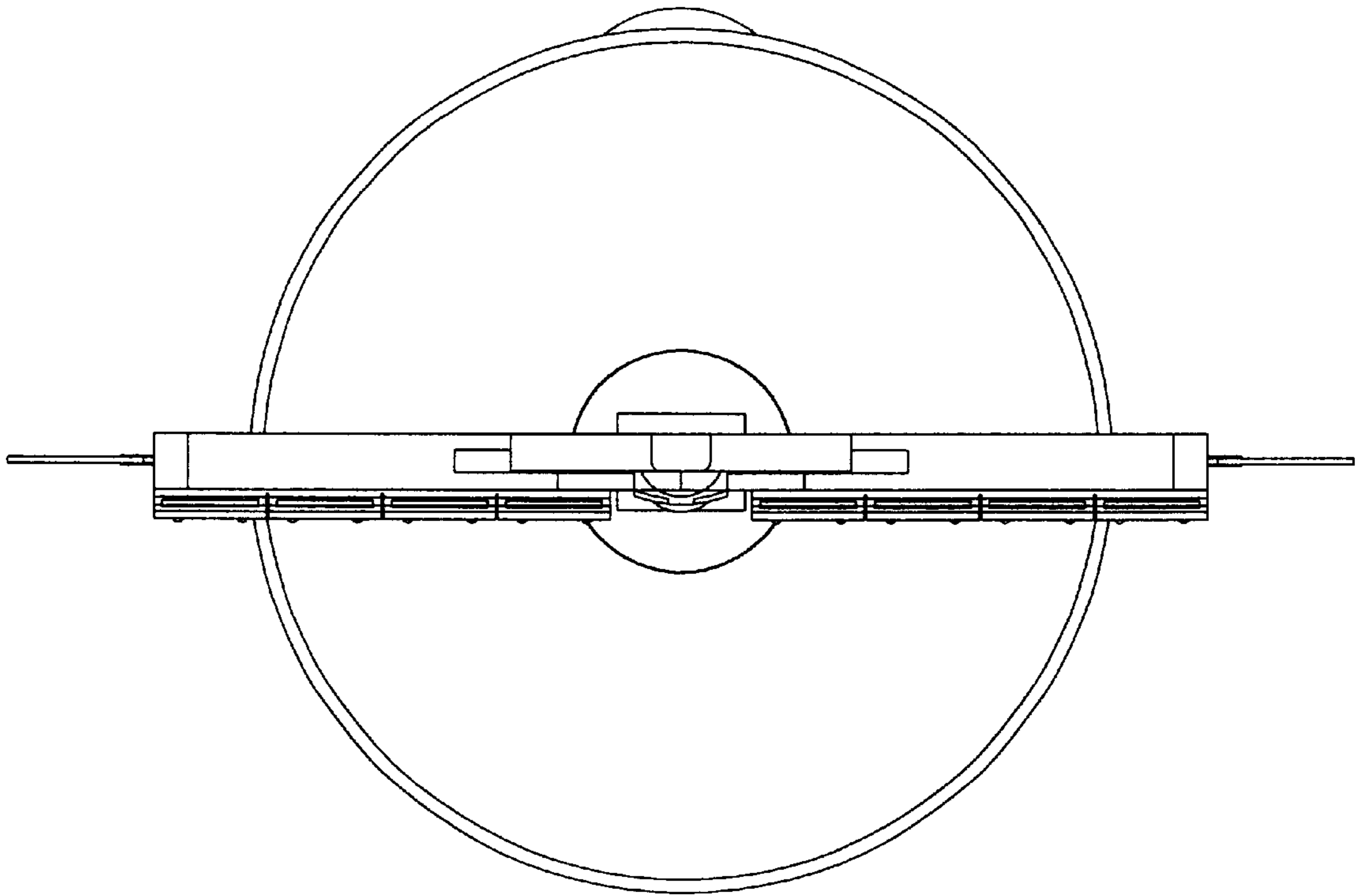

FIG. 5

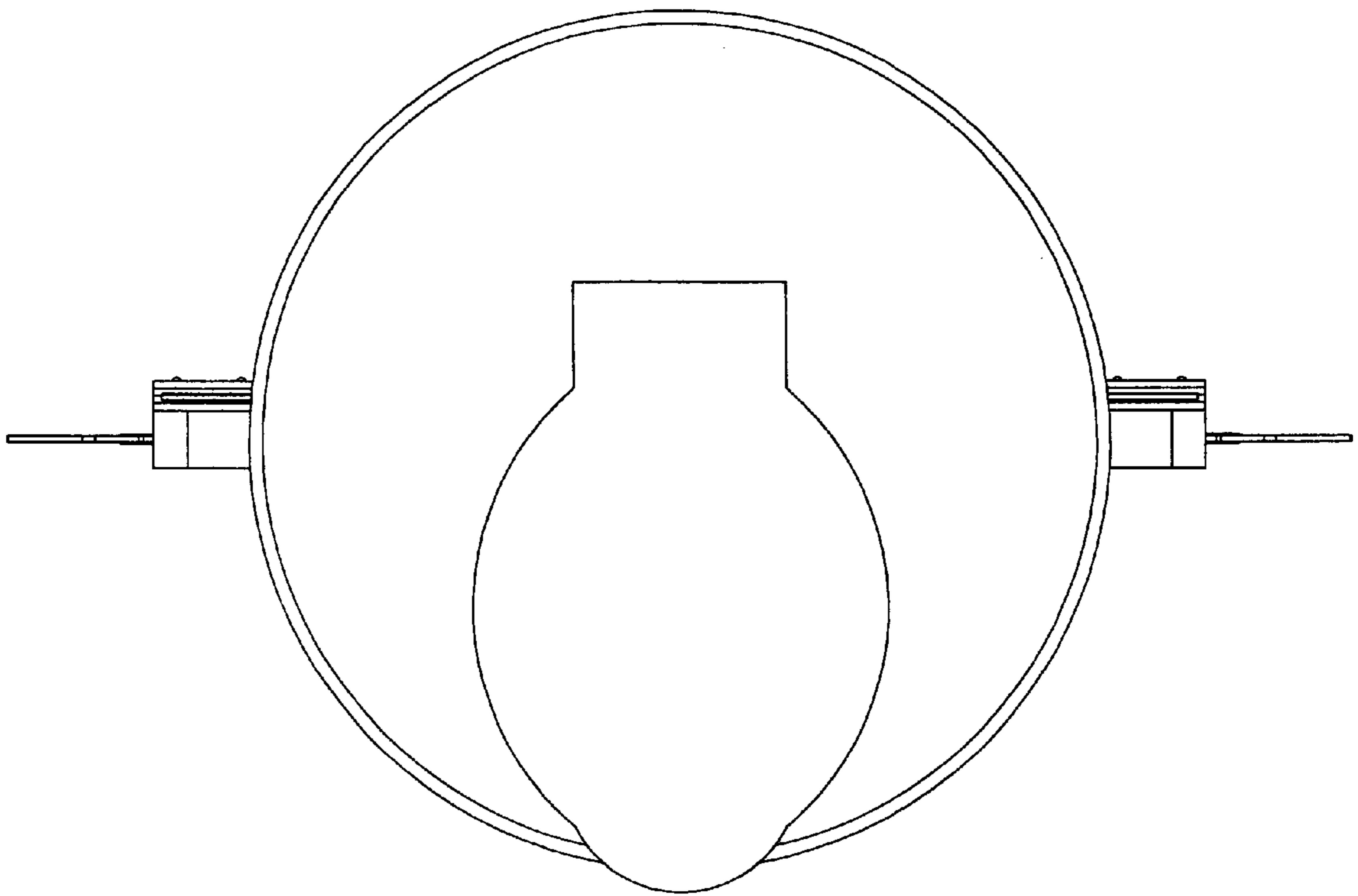

FIG. 6

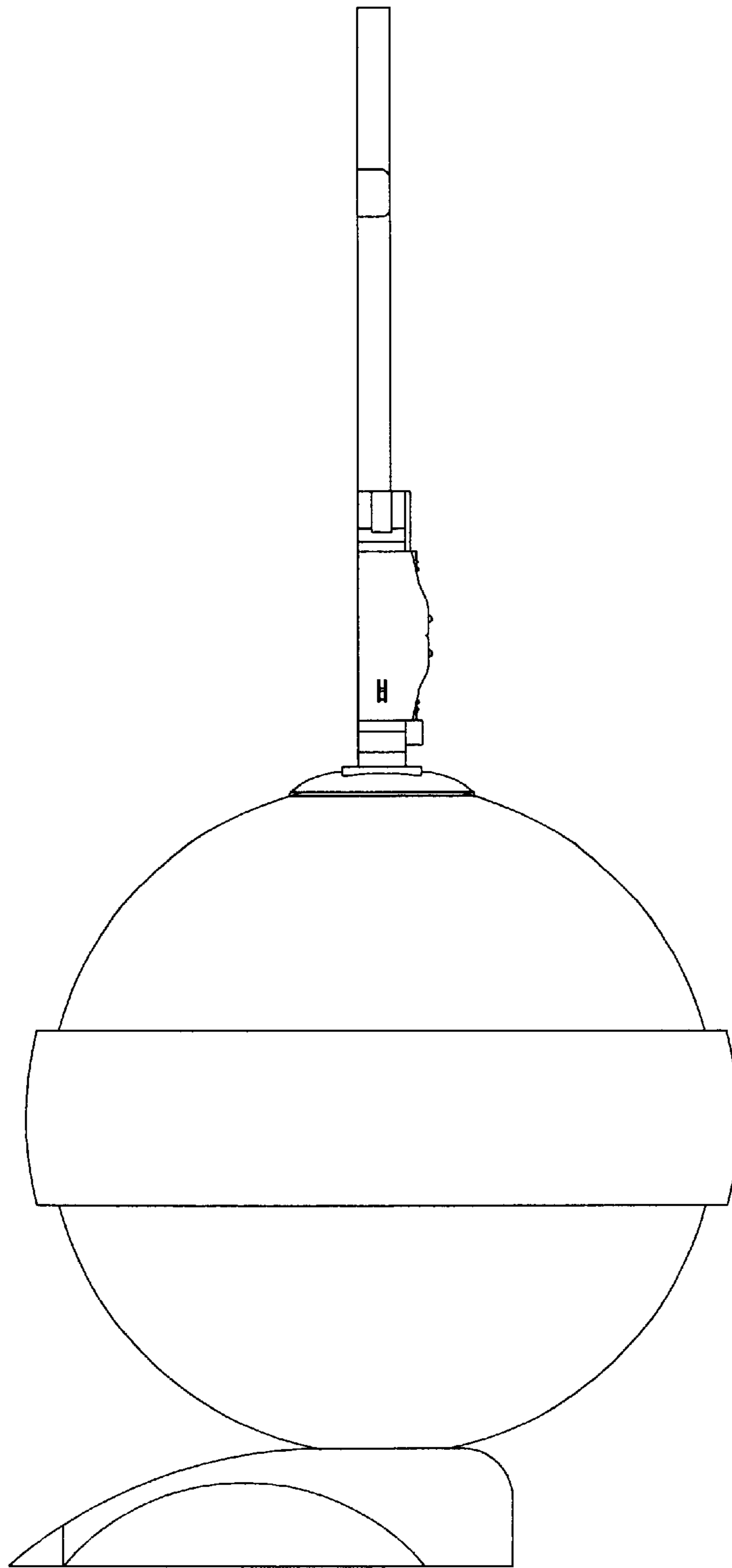

FIG. 7

