

US00D465749S

(12) **United States Design Patent**
Beigel

(10) **Patent No.:** **US D465,749 S**

(45) **Date of Patent:** **** Nov. 19, 2002**

(54) **HIGHWAY TRACTOR AND SLEEPER**

D445,361 S * 7/2001 Tirey D12/96
D447,099 S 8/2001 Tirey et al.

(75) Inventor: **David Joseph Beigel**, Kettering, OH
(US)

* cited by examiner

(73) Assignee: **International Truck and Engine Corporation Canada**, Warrenville, IL
(US)

Primary Examiner—Melody N. Brown
(74) *Attorney, Agent, or Firm*—Jeffrey P. Calfa; Neil T. Powell; Dennis Kelly Sullivan

(**) Term: **14 Years**

(57) **CLAIM**

(21) Appl. No.: **29/143,711**

The ornamental design for a highway tractor and sleeper, as shown and described.

(22) Filed: **Jun. 19, 2001**

DESCRIPTION

(51) **LOC (7) Cl.** **12-16**

(52) **U.S. Cl.** **D12/96**

(58) **Field of Search** D12/96, 97, 93;
296/180.1, 190, 91, 180.2; 180/89.12, 89.13

FIG. 1 is a right front perspective view of a highway tractor and sleeper showing my new design;
FIG. 2 is a left front perspective view thereof;
FIG. 3 is a left side view thereof, the right side being substantially a mirror image of that shown;
FIG. 4 is a front view thereof; and,
FIG. 5 is a top view thereof.

(56) **References Cited**

U.S. PATENT DOCUMENTS

D391,908 S 3/1998 Allendorph et al.

1 Claim, 5 Drawing Sheets

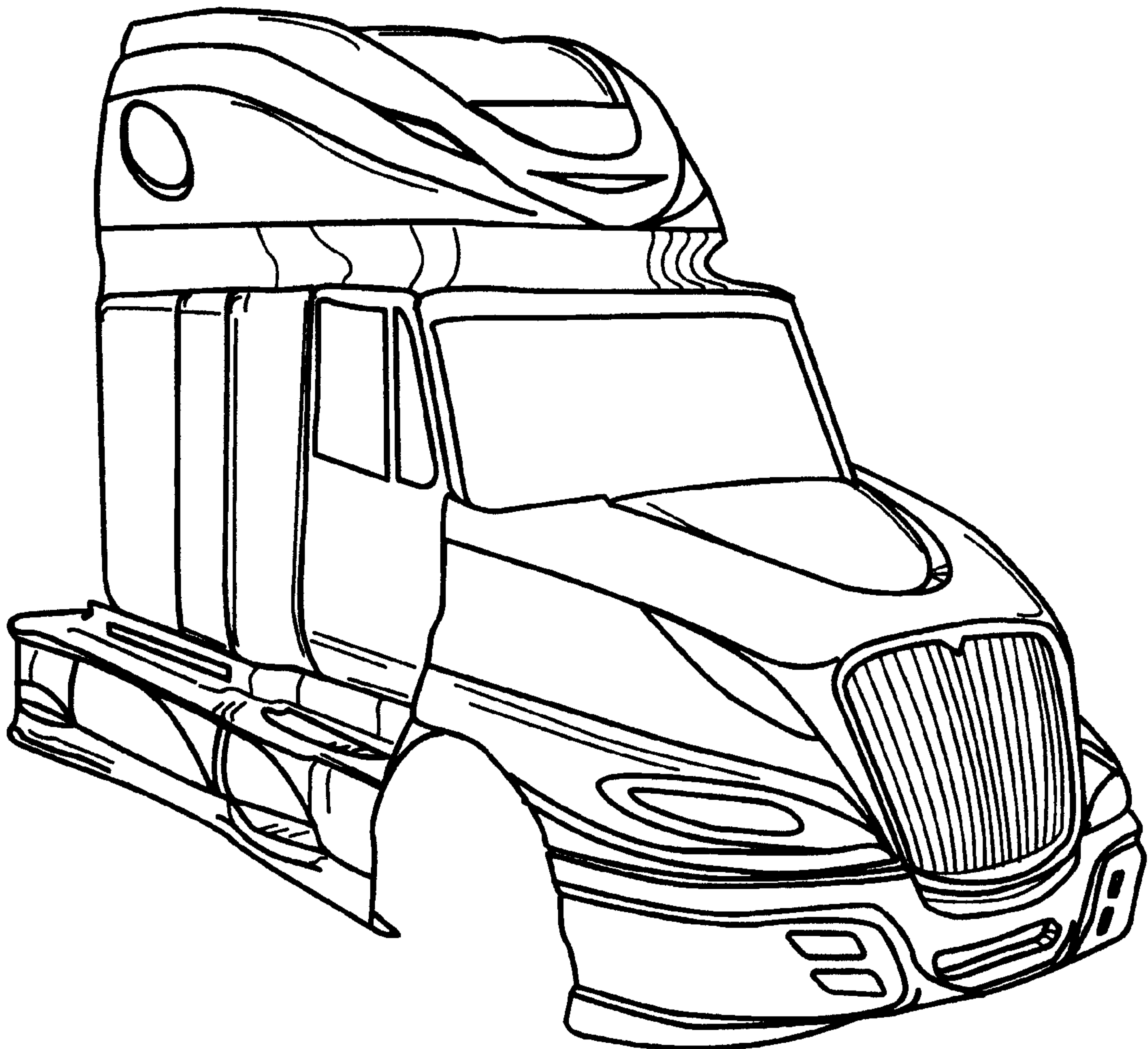

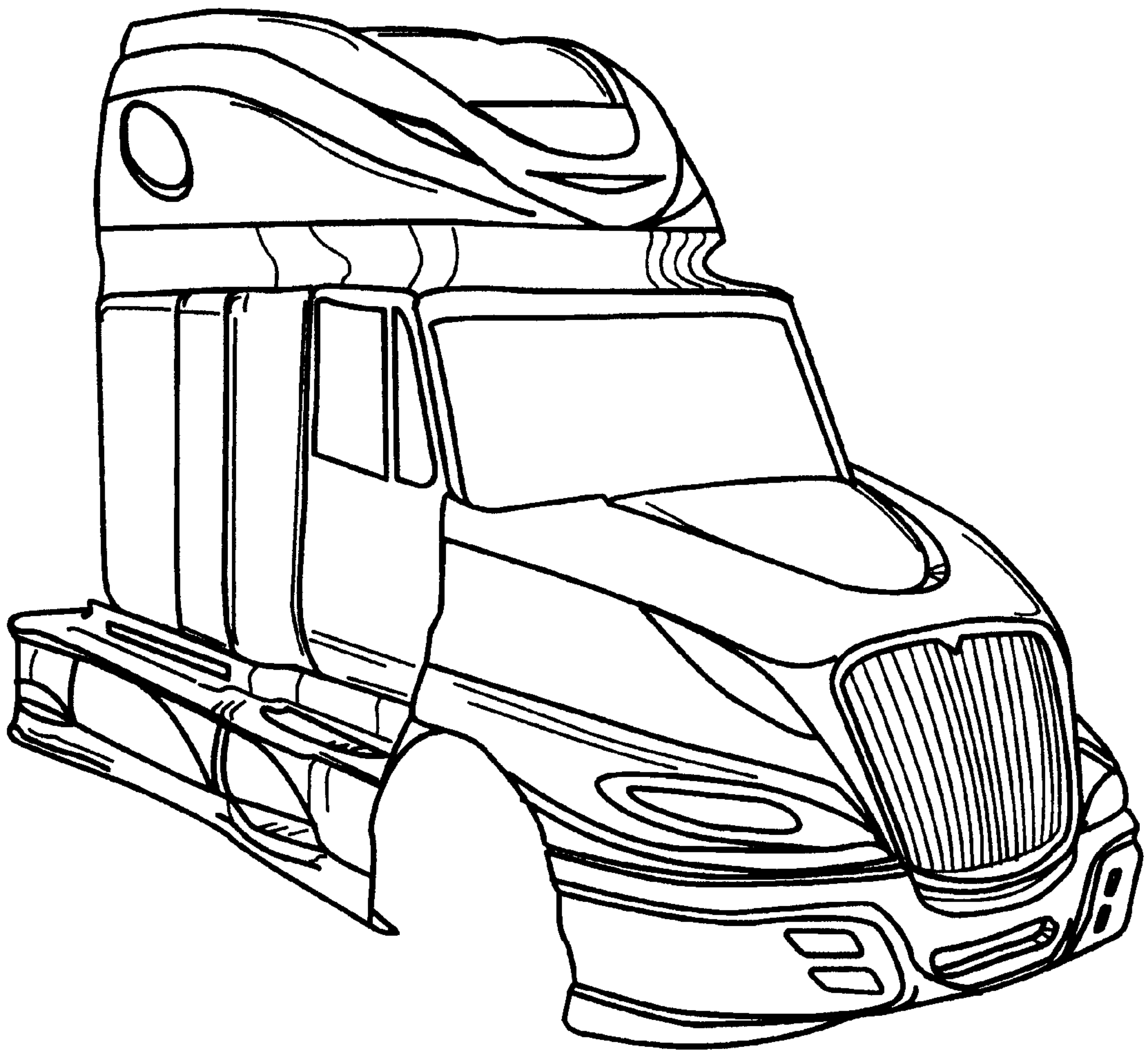

FIG. 1

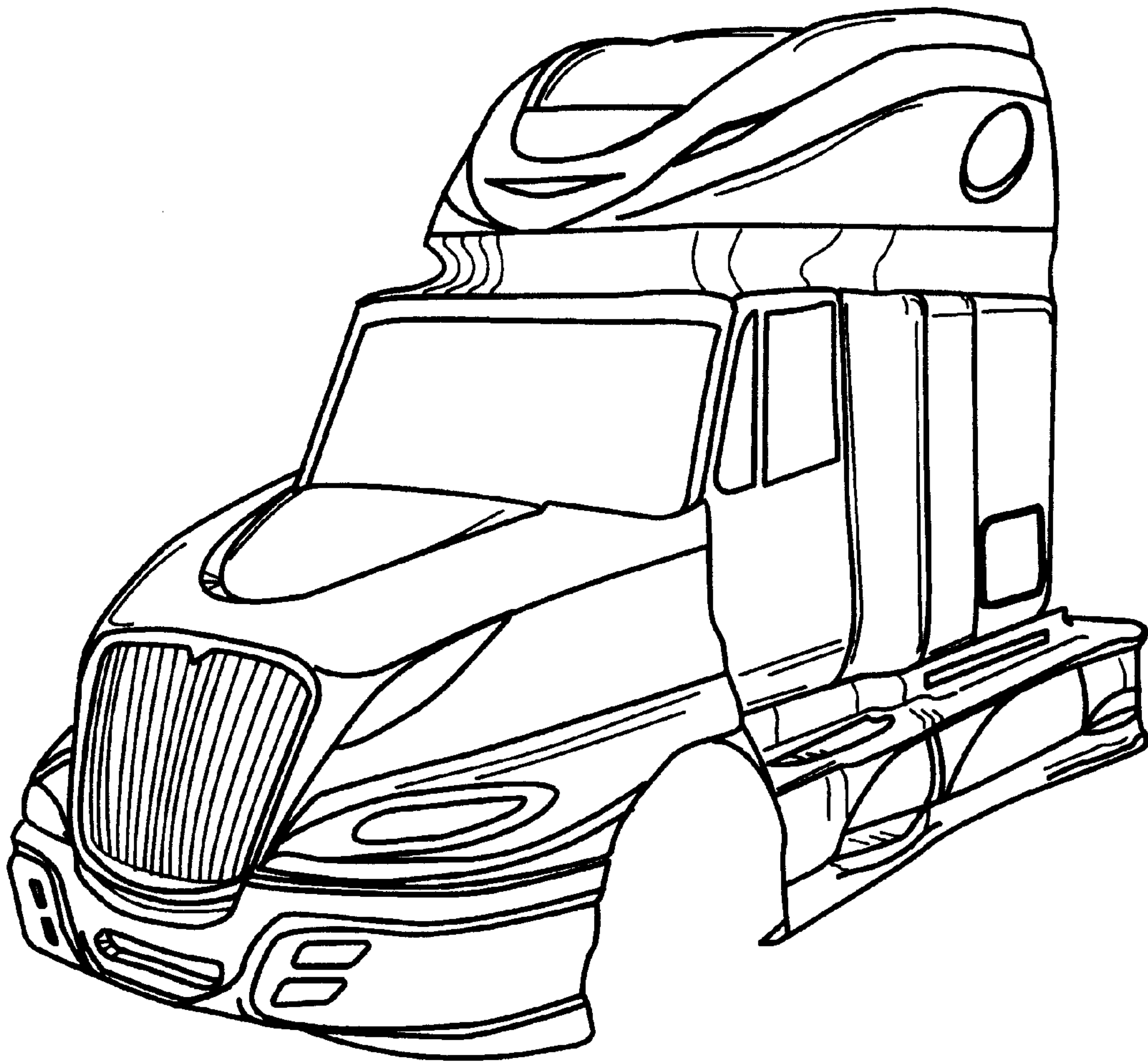

FIG. 2

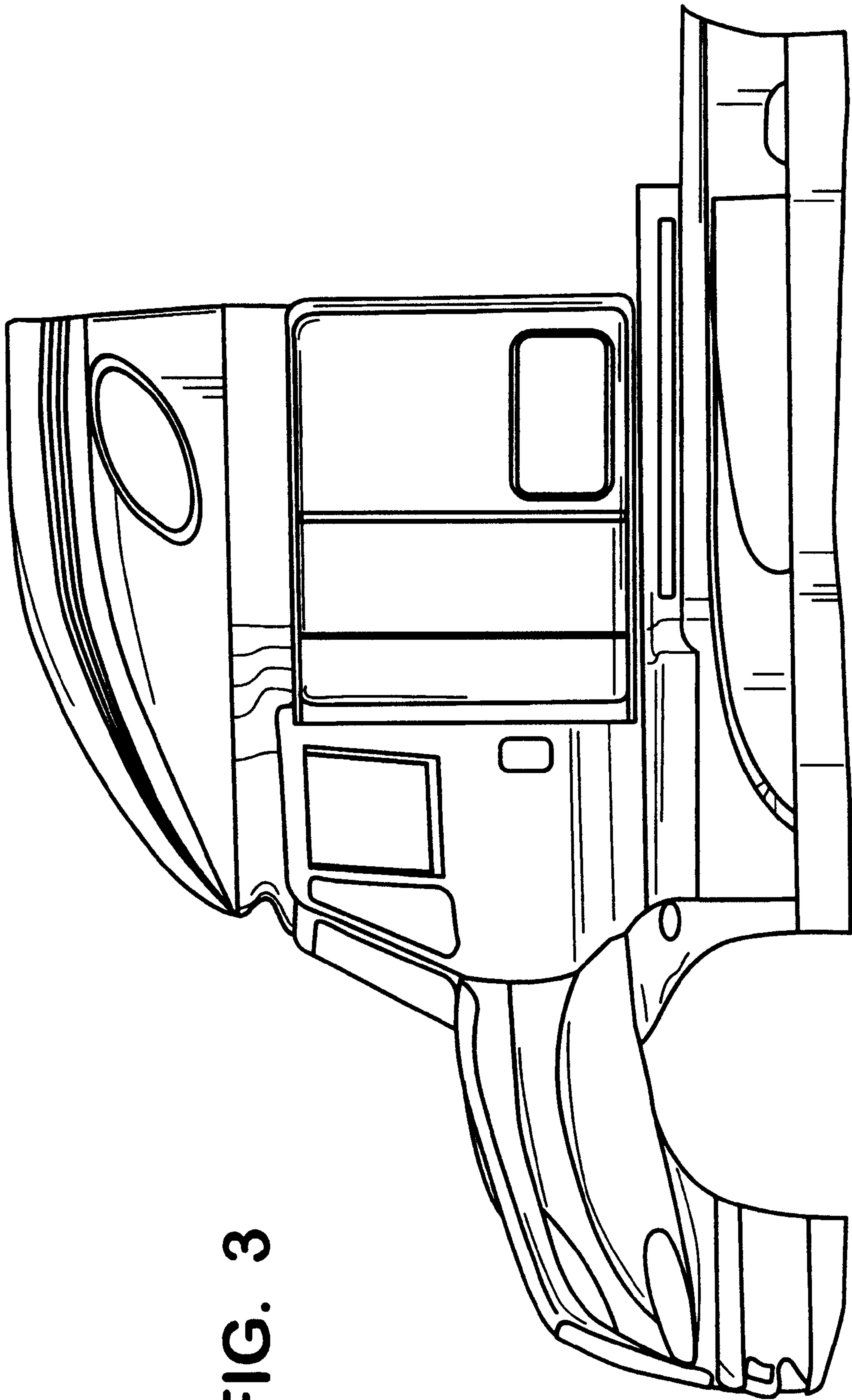

FIG. 3

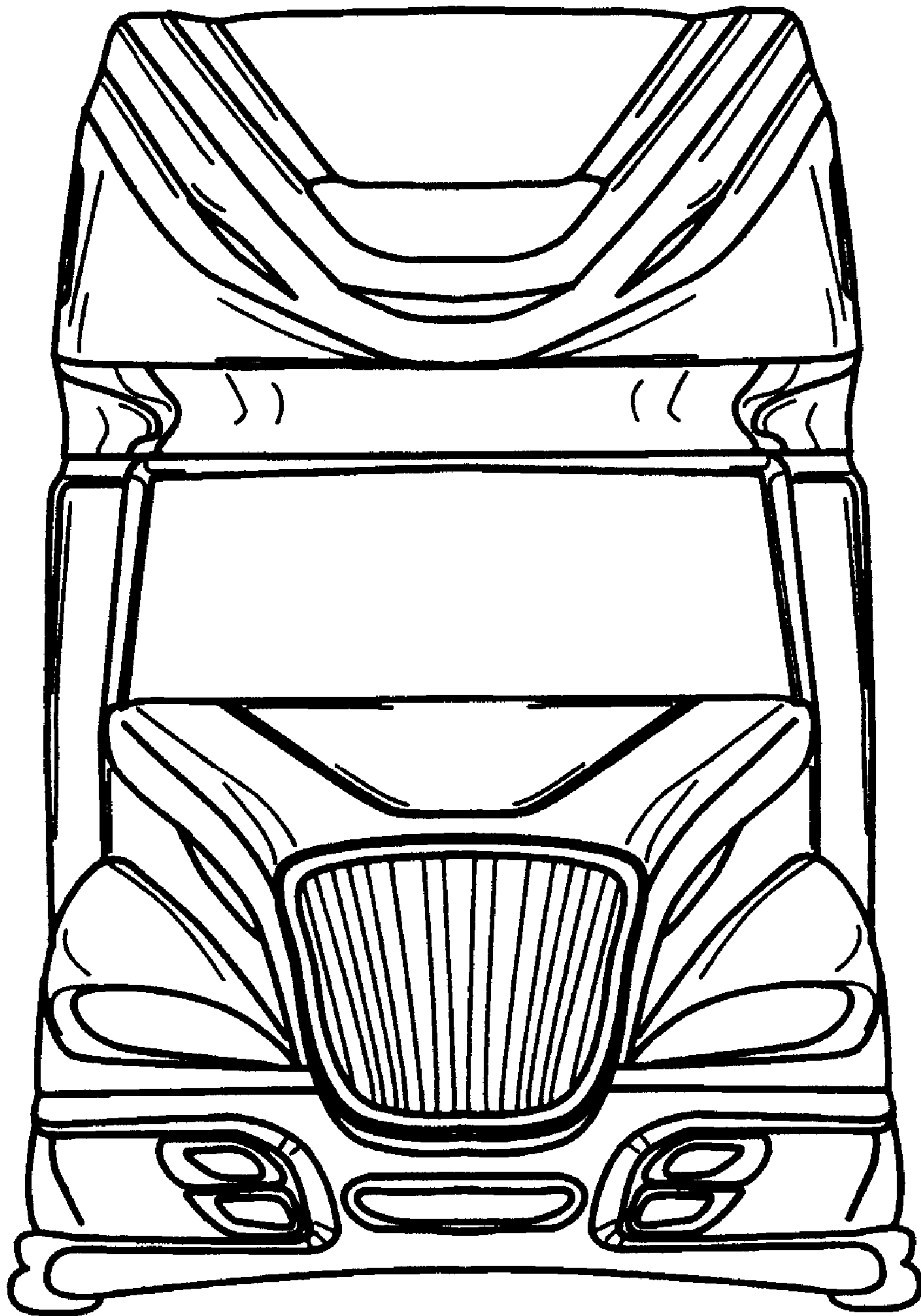

FIG. 4

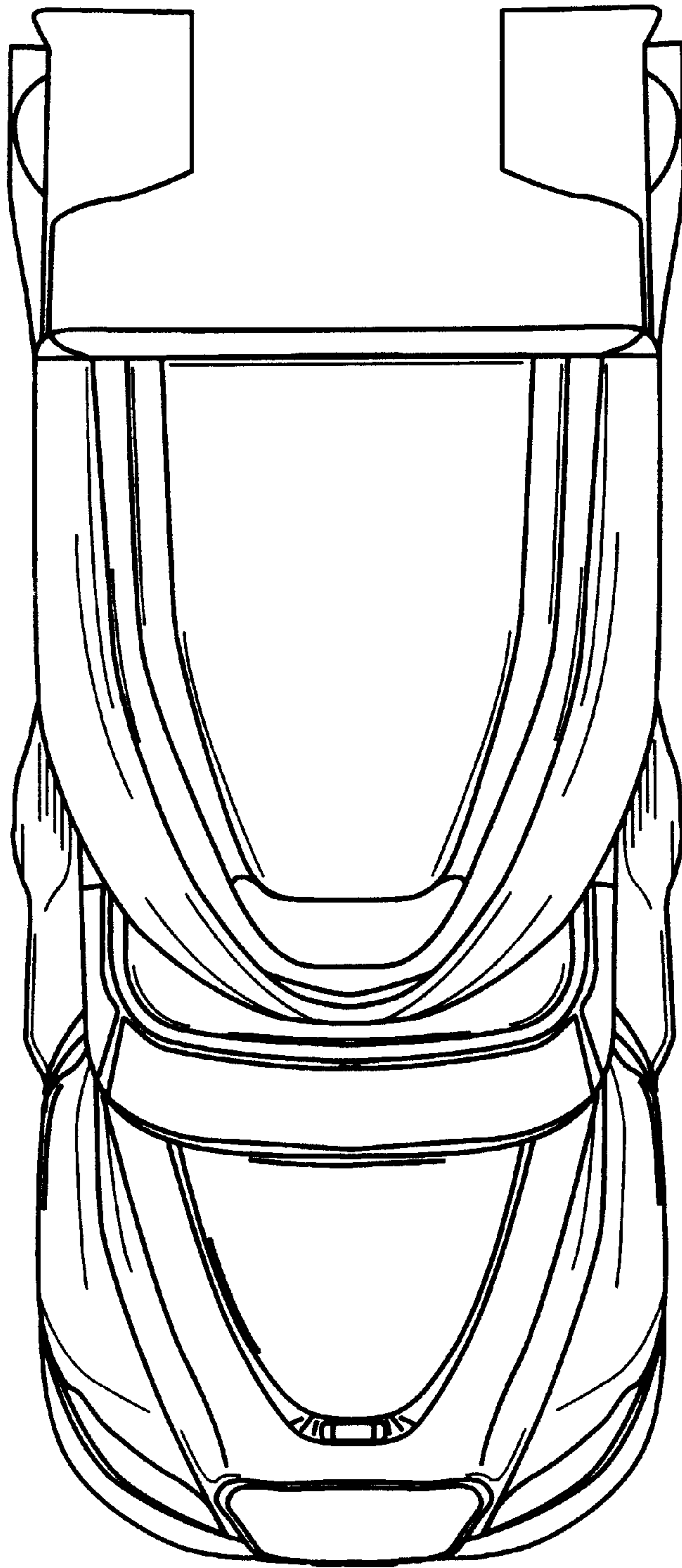

FIG. 5