



US00D465437S

(12) **United States Design Patent**  
**van der Veer**

(10) **Patent No.:** **US D465,437 S**

(45) **Date of Patent:** **\*\* Nov. 12, 2002**

(54) **BICYCLE**

(75) Inventor: **Popke Binne van der Veer**, GC Deil (NL)

(73) Assignee: **Prima Ricerca & Sviluppo SpA**, Olgiate Comasco-Localita (IT)

(\*\*) Term: **14 Years**

(21) Appl. No.: **29/138,660**

(22) Filed: **Mar. 14, 2001**

(30) **Foreign Application Priority Data**

Sep. 14, 2000 (XH) ..... DM/056 978

(51) **LOC (7) Cl.** ..... **12-11**

(52) **U.S. Cl.** ..... **D12/111**

(58) **Field of Search** ..... D12/110, 111; 280/274-280, 281.1, 282-288, 288.1-288.3

(56) **References Cited**

**U.S. PATENT DOCUMENTS**

2,495,859 A \* 1/1950 Mennesson ..... 280/281.1

D401,534 S \* 11/1998 Higashihara et al. .... D12/110

D402,925 S \* 12/1998 Kino et al. .... D12/110

\* cited by examiner

*Primary Examiner*—Alan P. Douglas

*Assistant Examiner*—Linda Brooks

(74) *Attorney, Agent, or Firm*—Christensen O'Connor Johnson Kindness PLLC

(57) **CLAIM**

The ornamental design for a bicycle, as shown and described.

**DESCRIPTION**

FIG. 1 is a top plan view of my new bicycle; FIG. 2 is a front elevational view thereof; FIG. 3 is a left side elevational view thereof; FIG. 4 is a rear elevational view thereof; FIG. 5 is a right side elevational view thereof; FIG. 6 is a bottom plan view thereof; FIG. 7 is a top perspective view of an alternate embodiment of my new bicycle; FIG. 8 is a front elevational view of the alternate embodiment of FIG. 7; FIG. 9 is a left side elevational view thereof; FIG. 10 is a rear elevational view thereof; FIG. 11 is a right side elevational view thereof; and, FIG. 12 is a bottom view thereof.

**1 Claim, 4 Drawing Sheets**

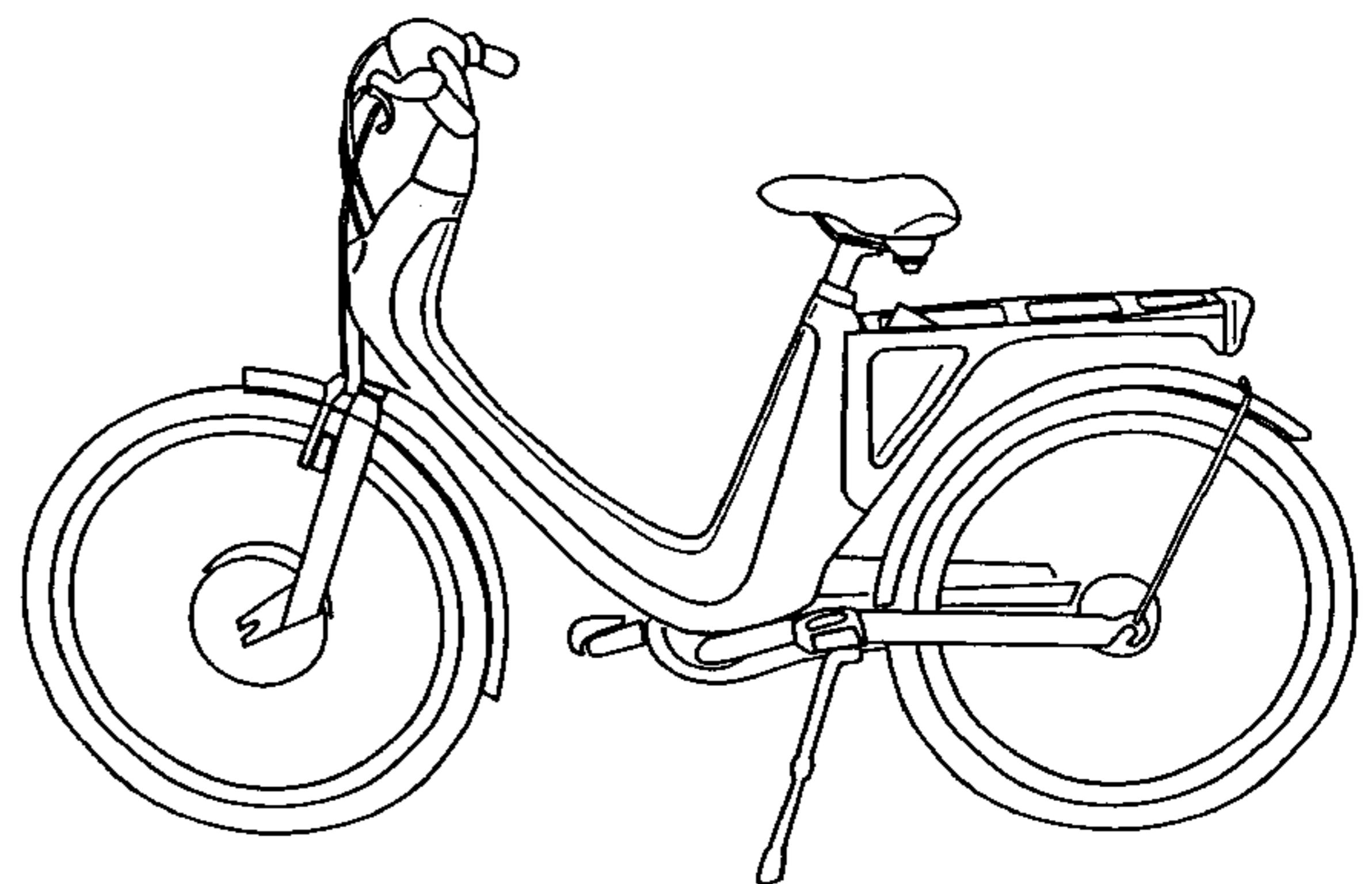
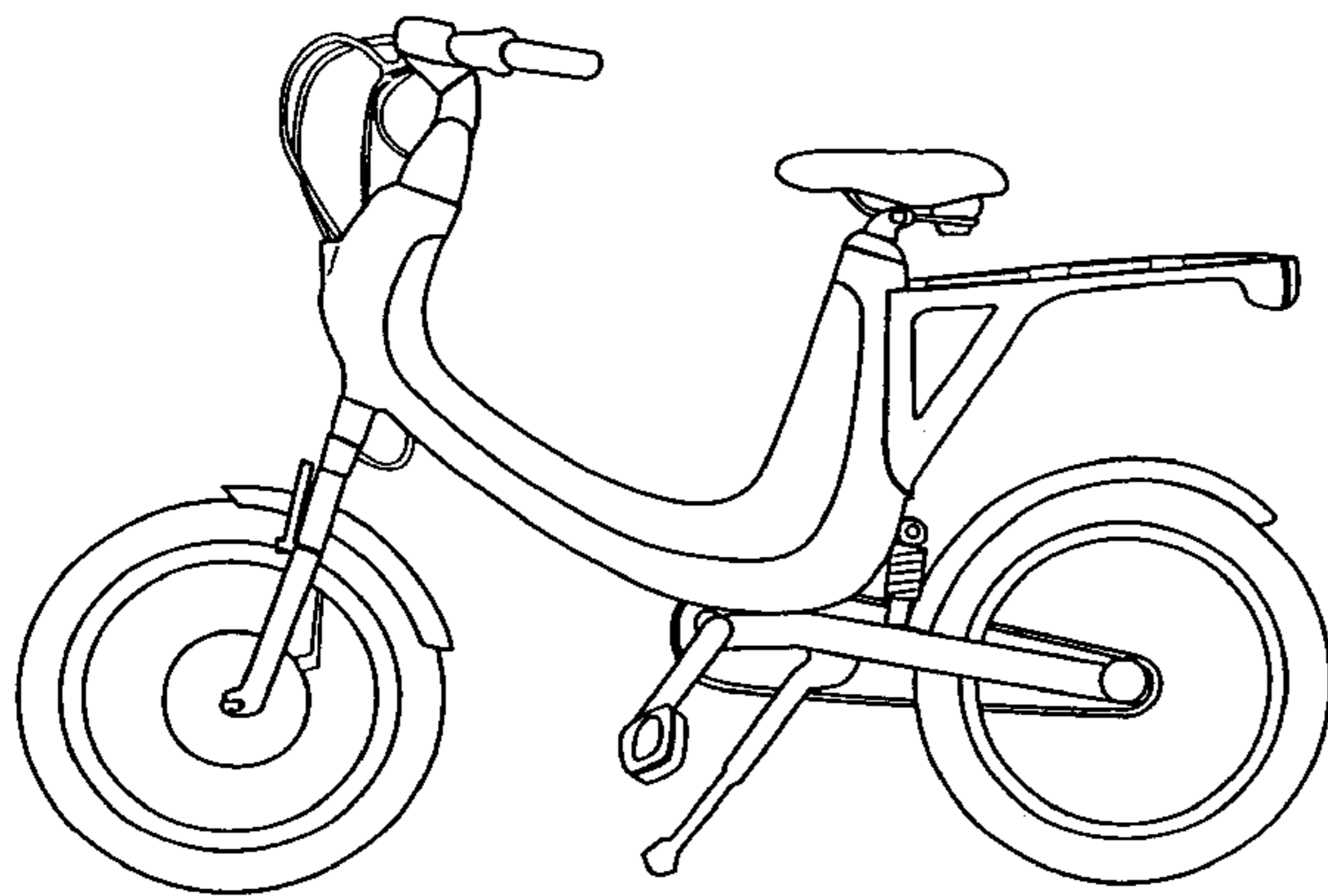

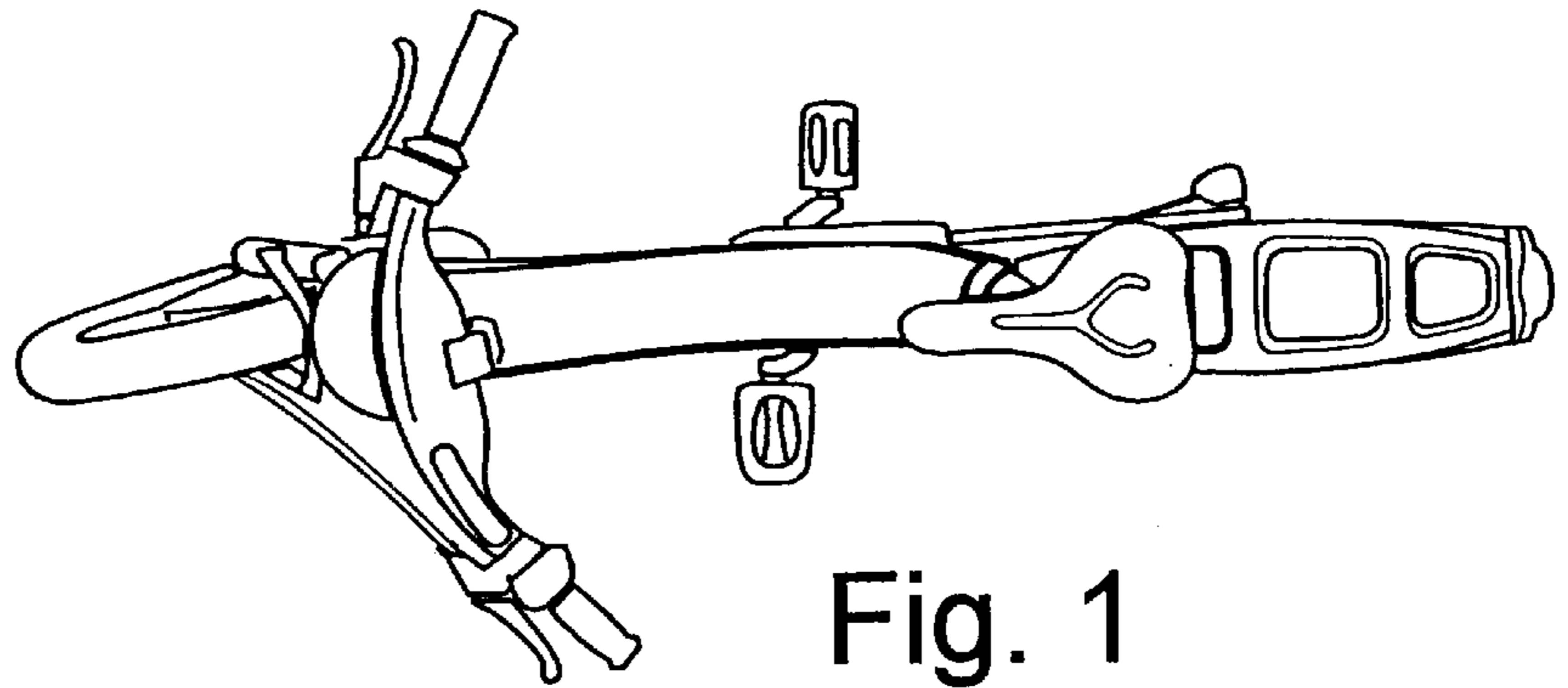

Fig. 1

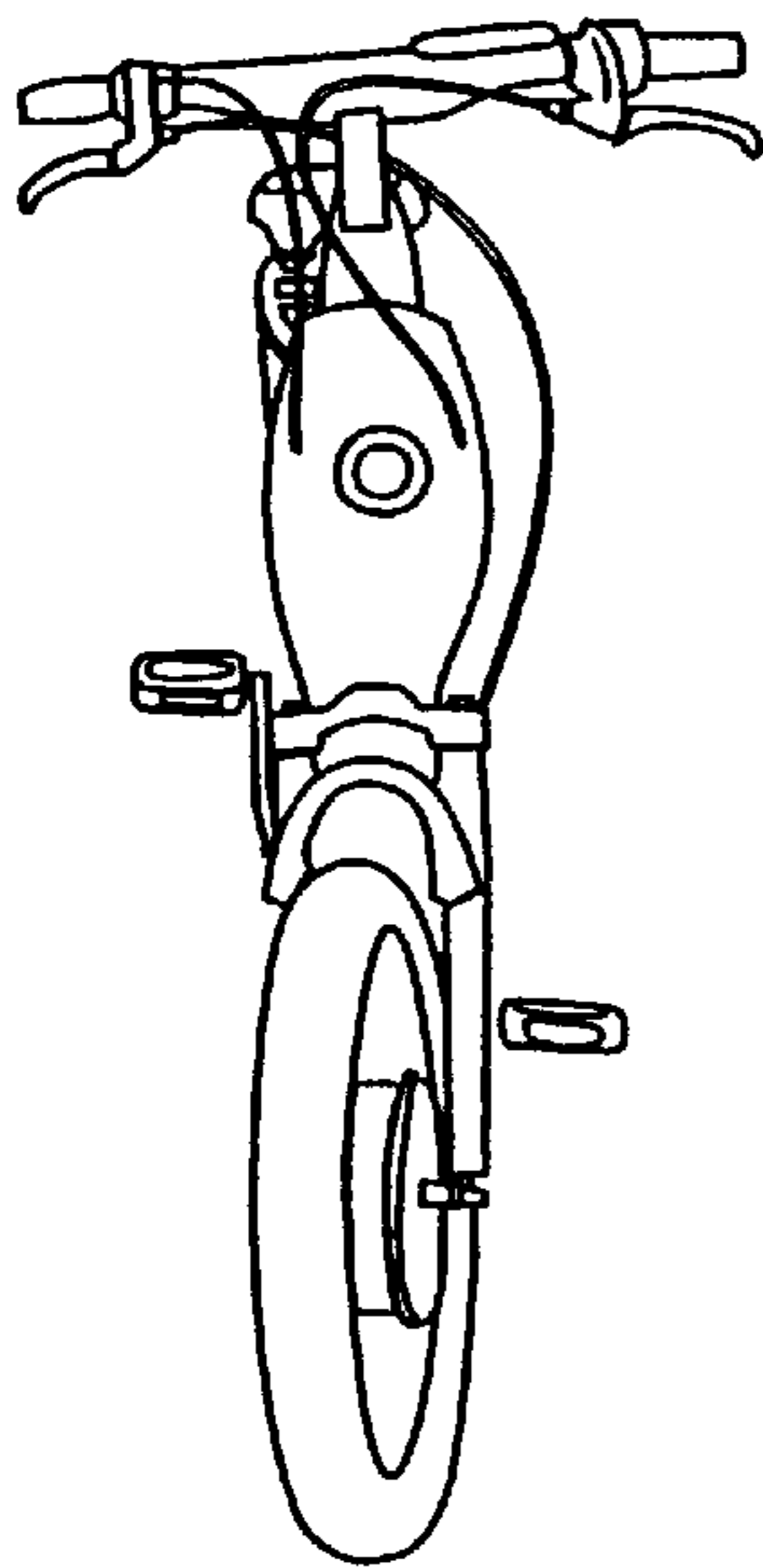

Fig. 2

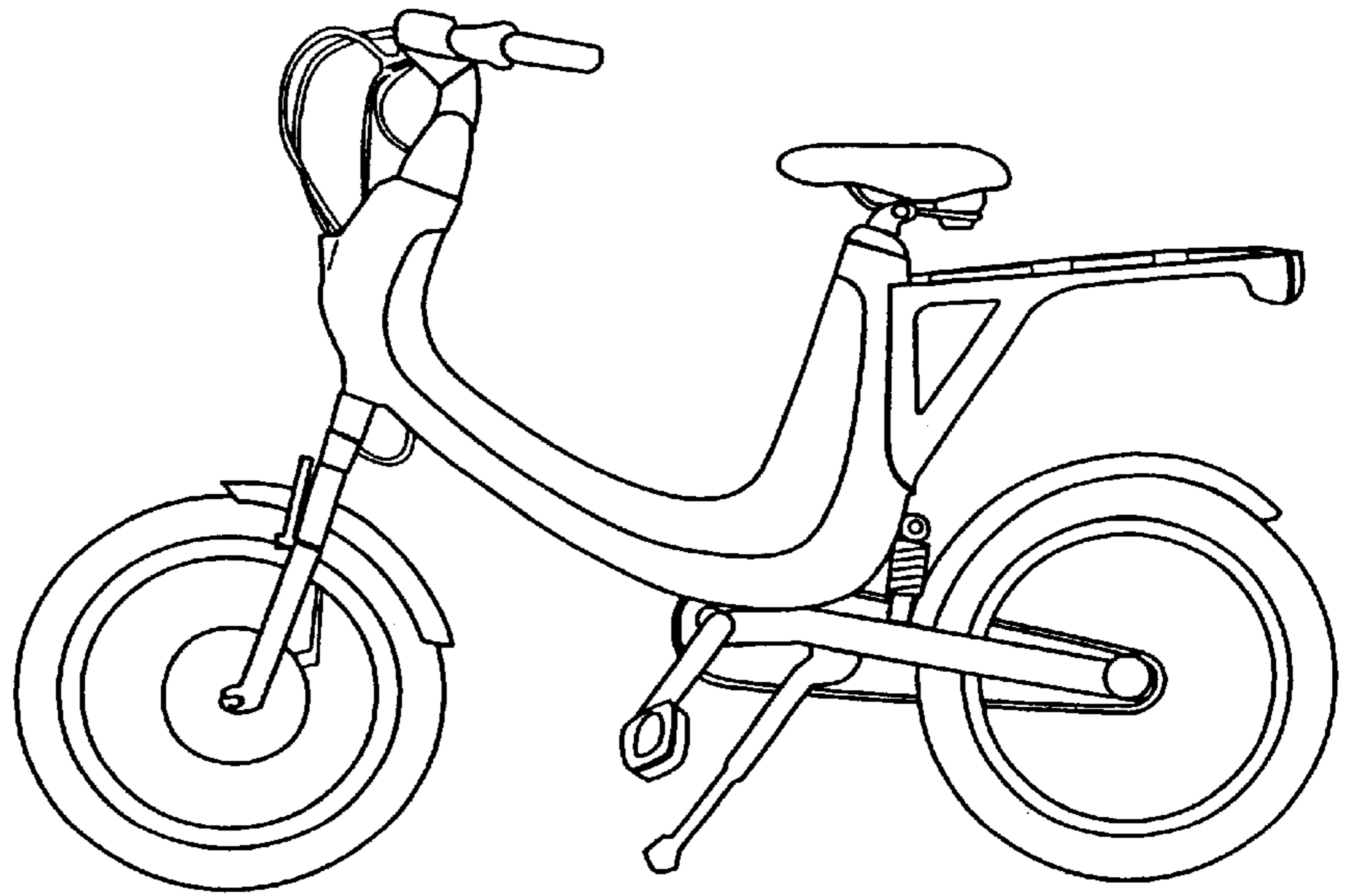

Fig. 3

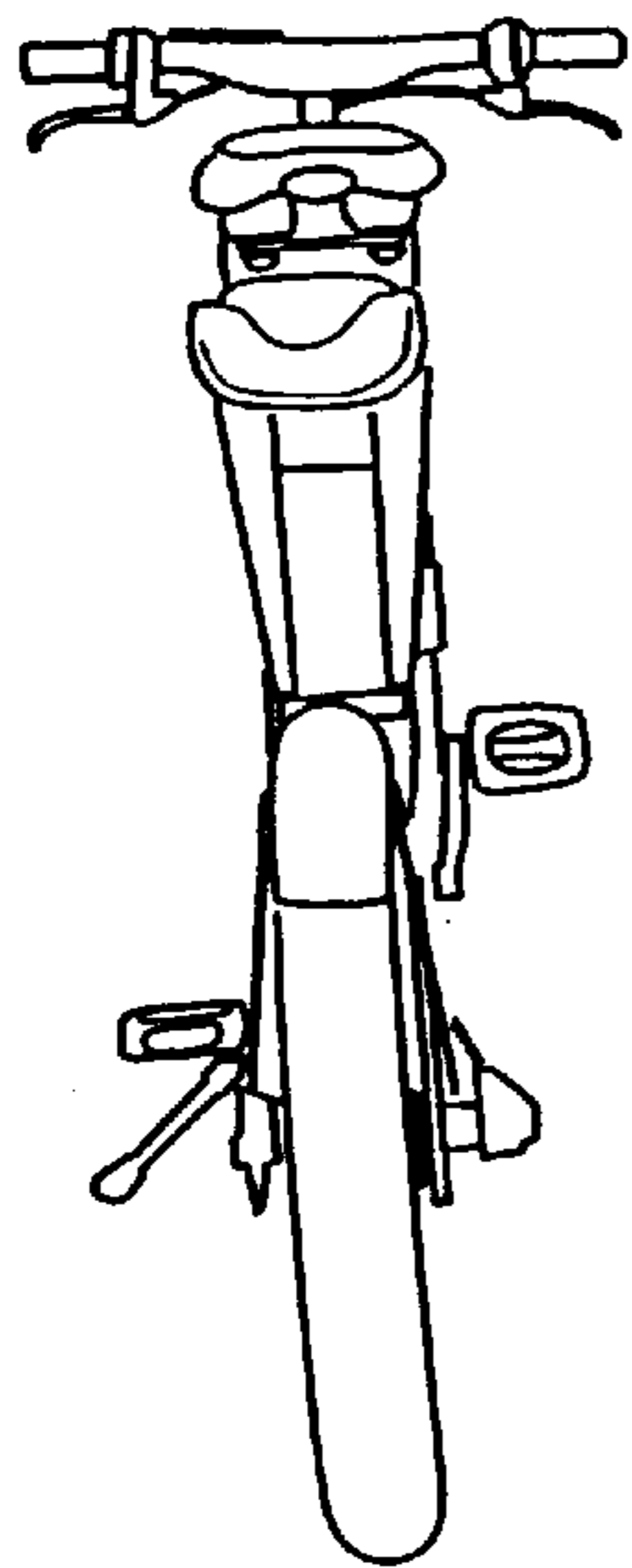

Fig. 4

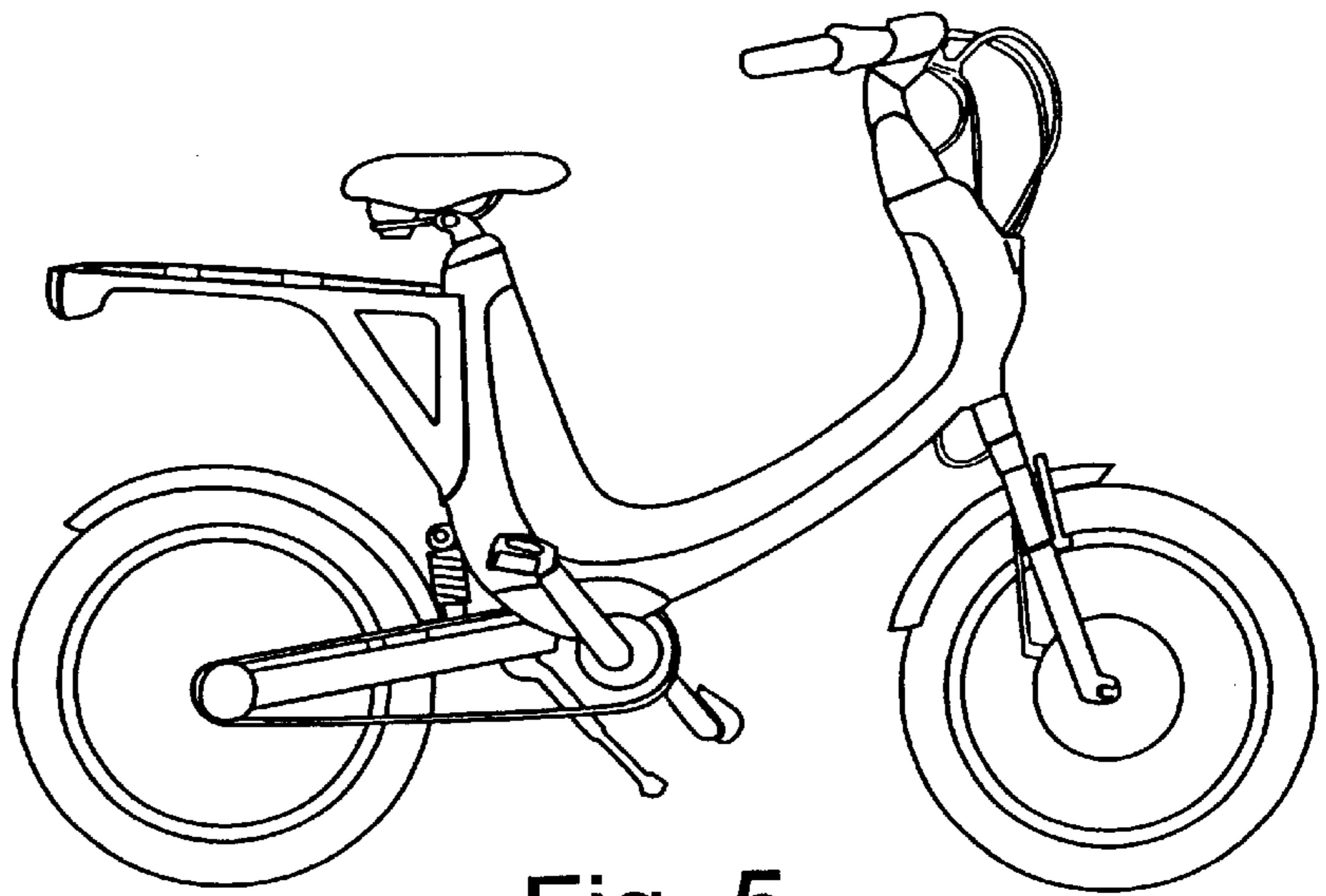

Fig. 5

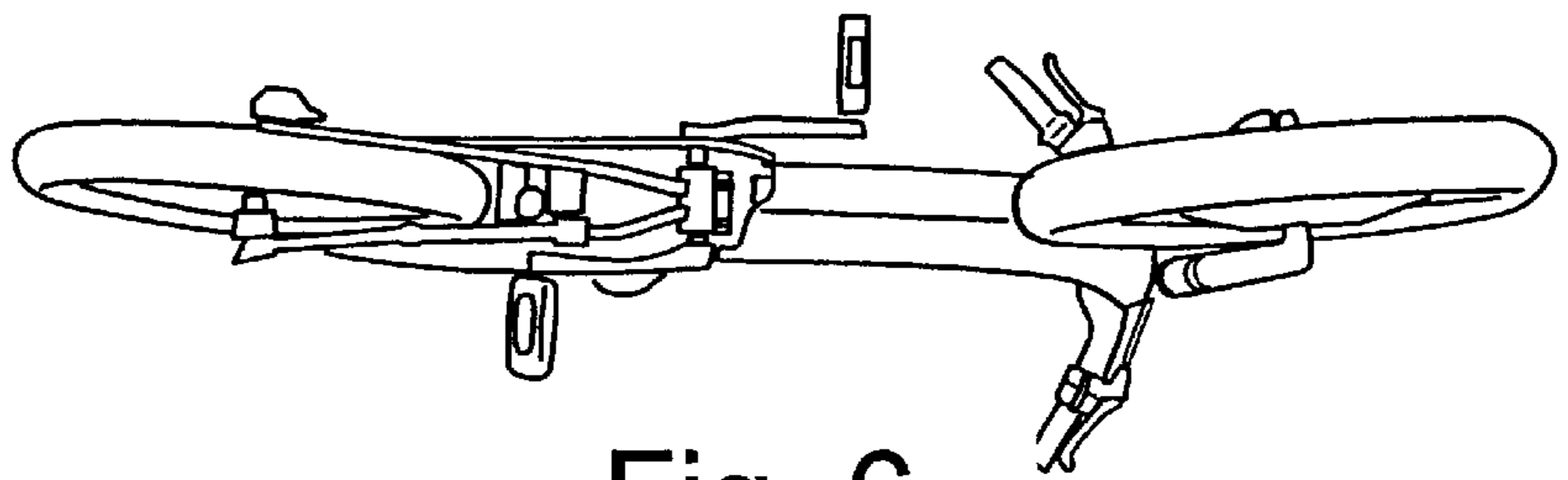

Fig. 6

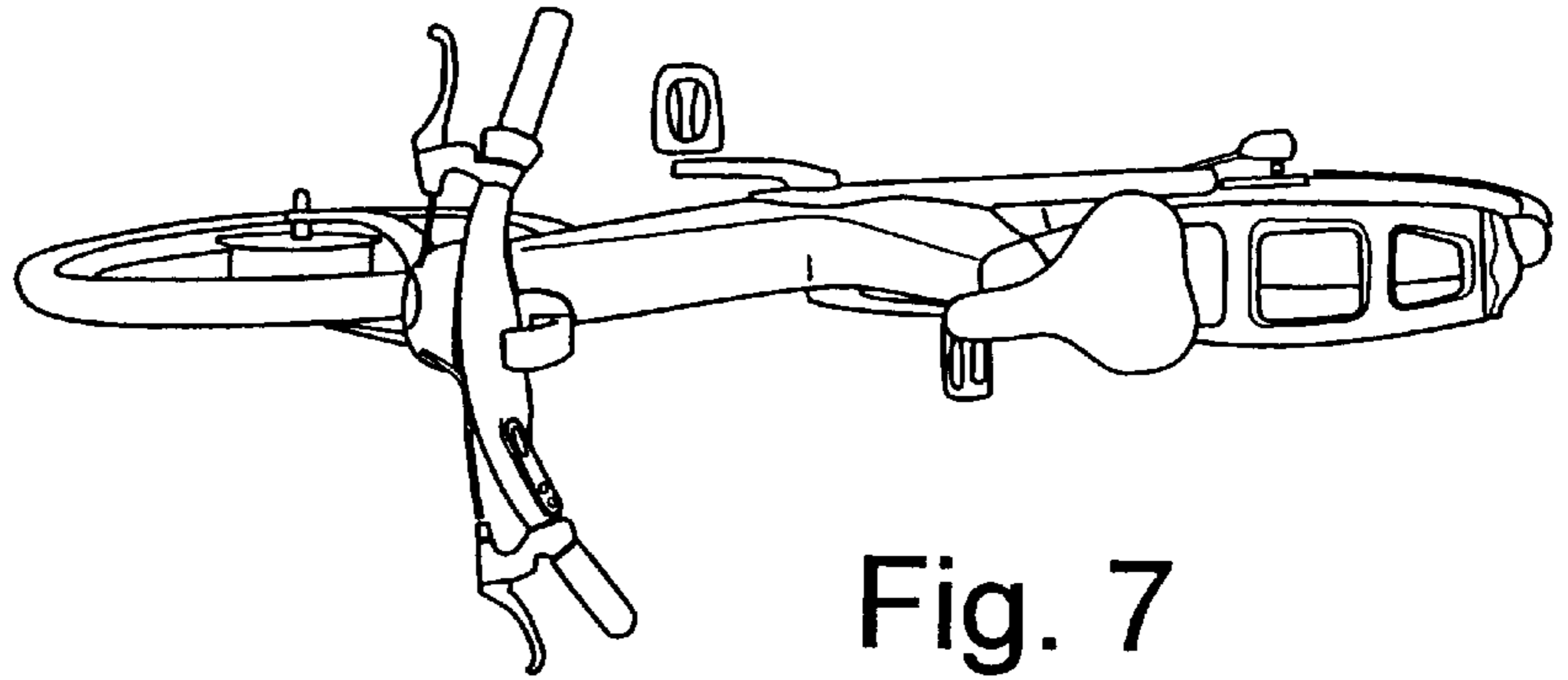

Fig. 7

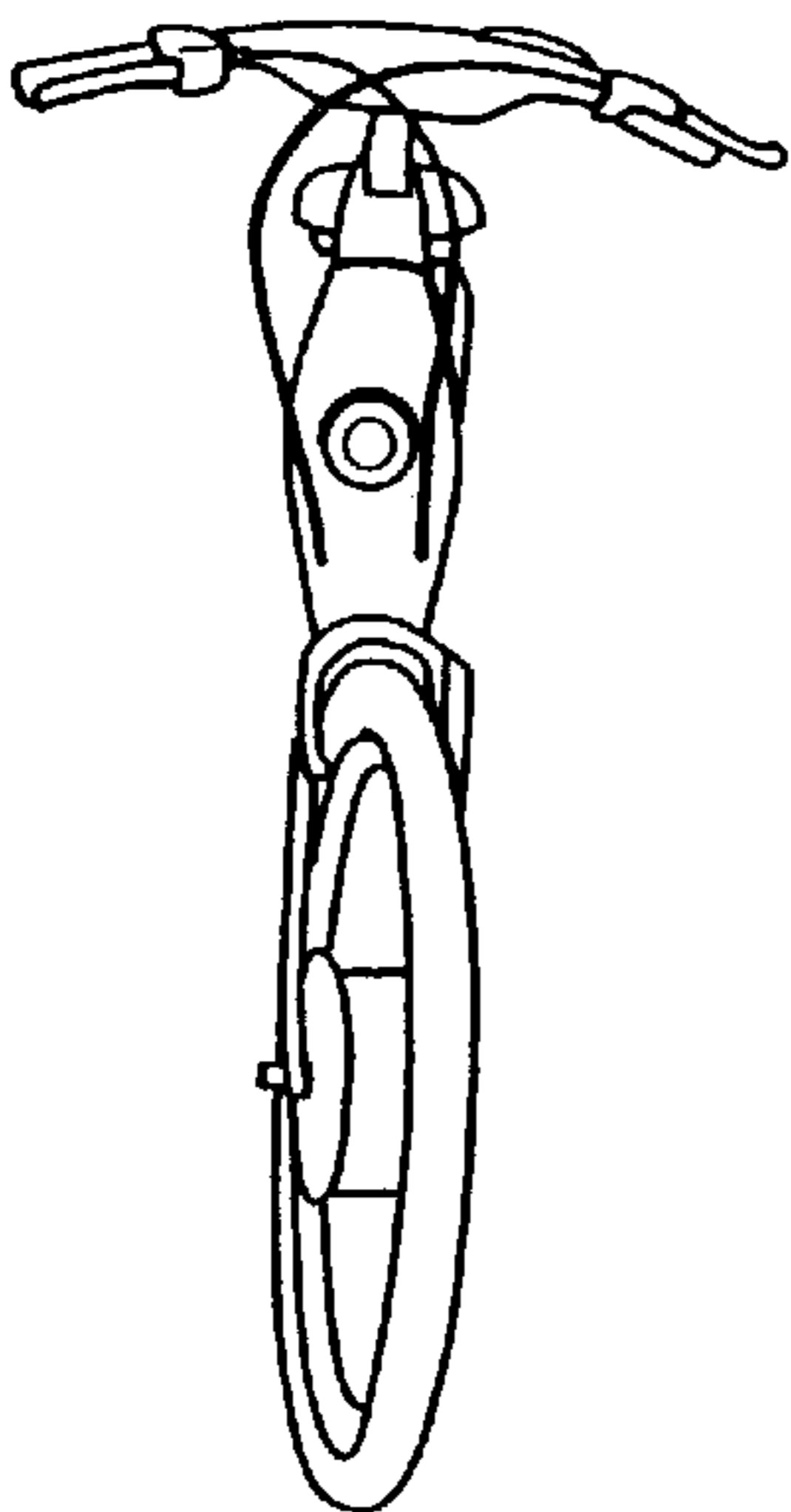

Fig. 8

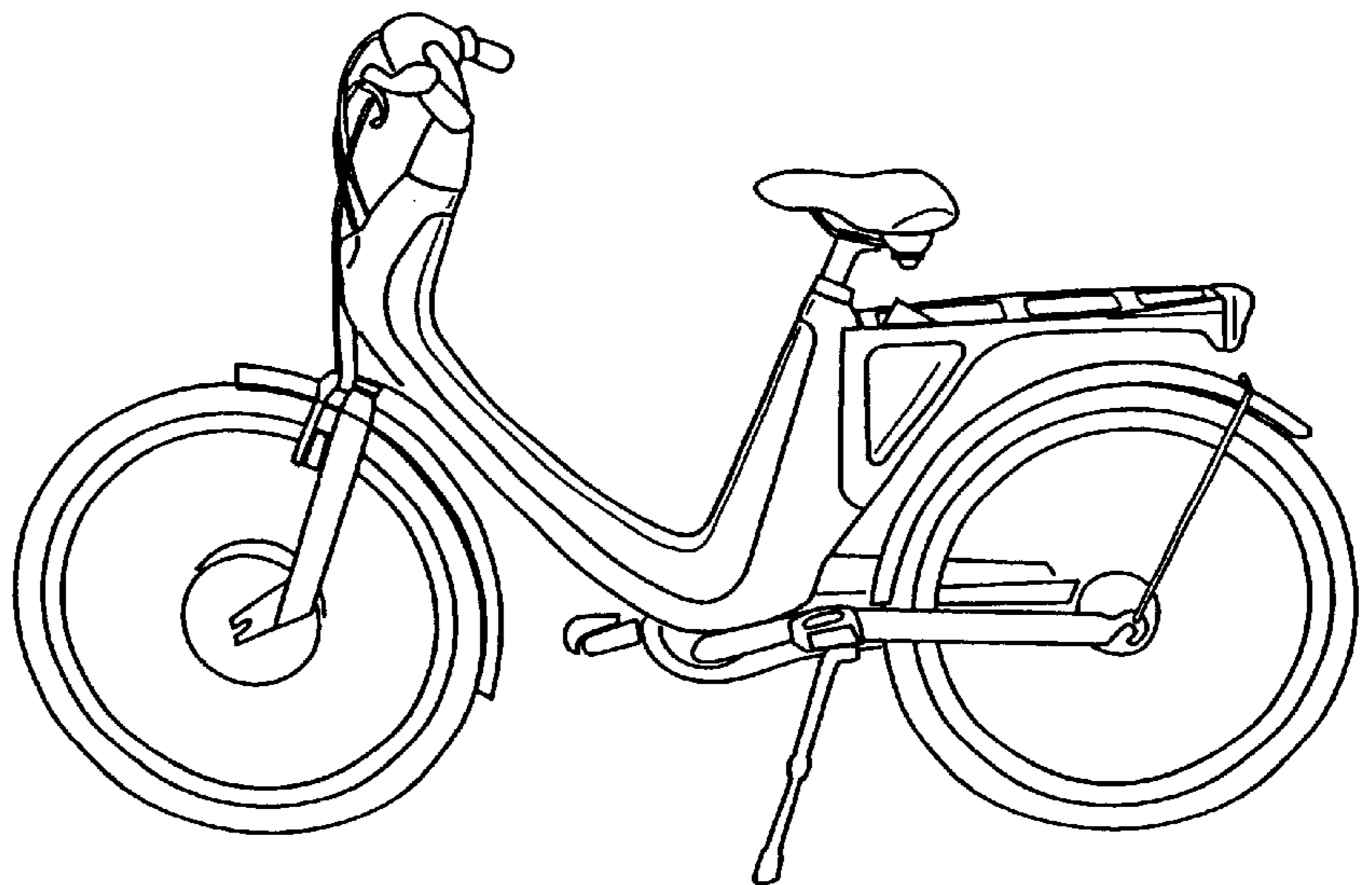

Fig. 9

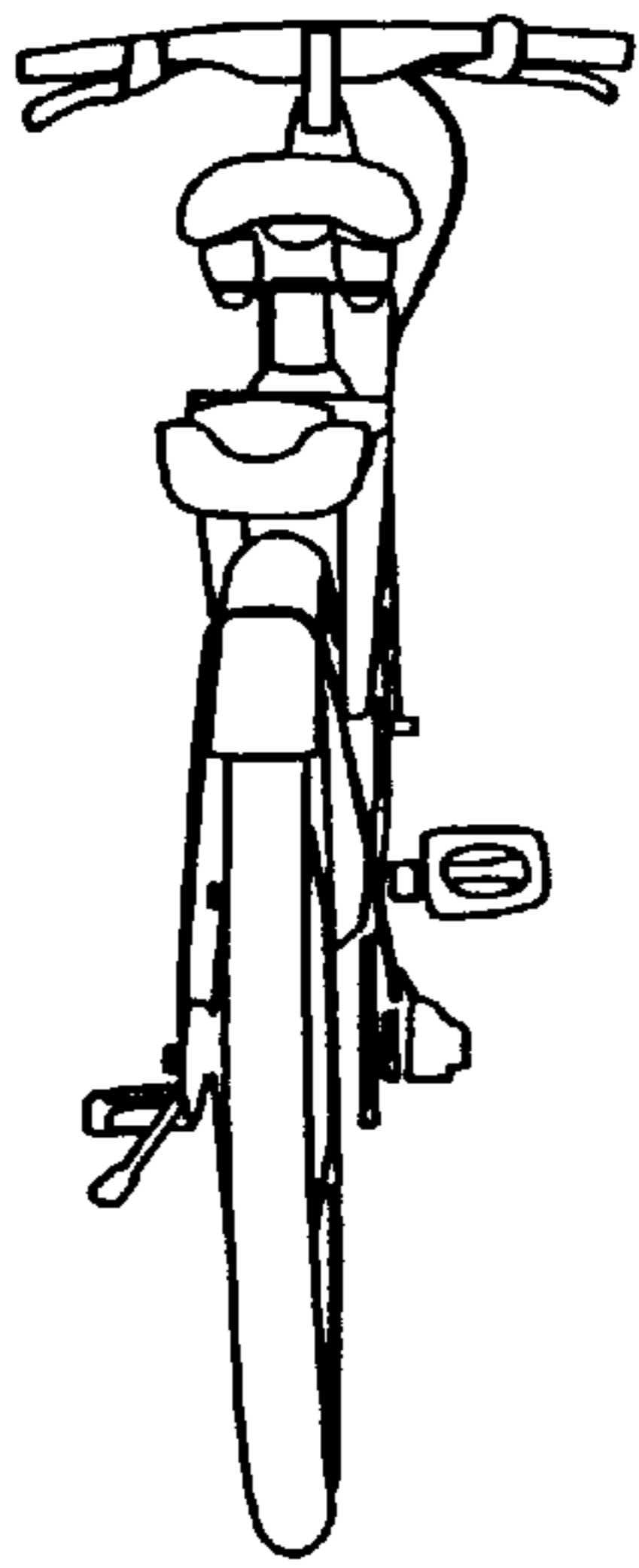

Fig. 10

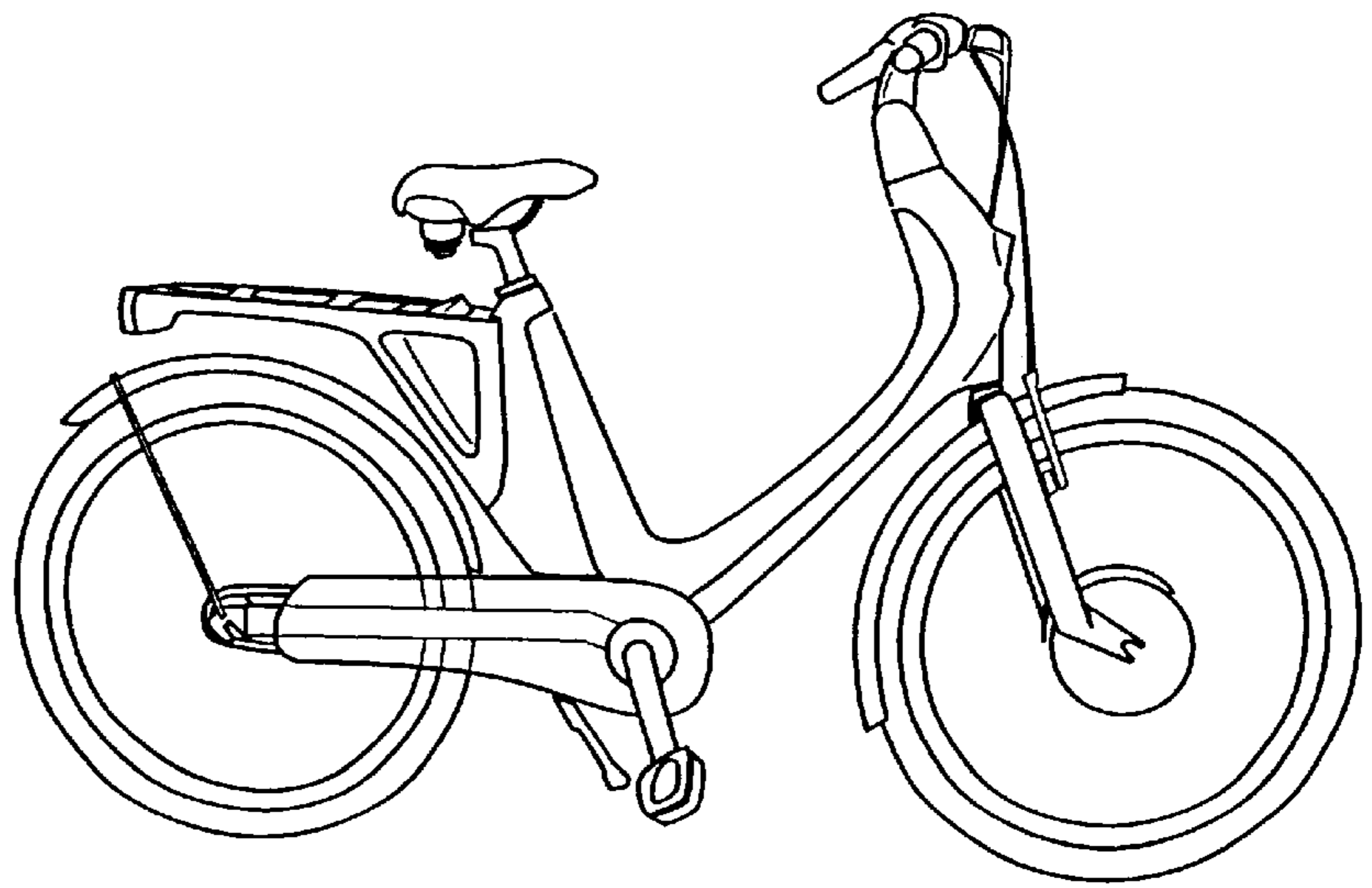

Fig. 11

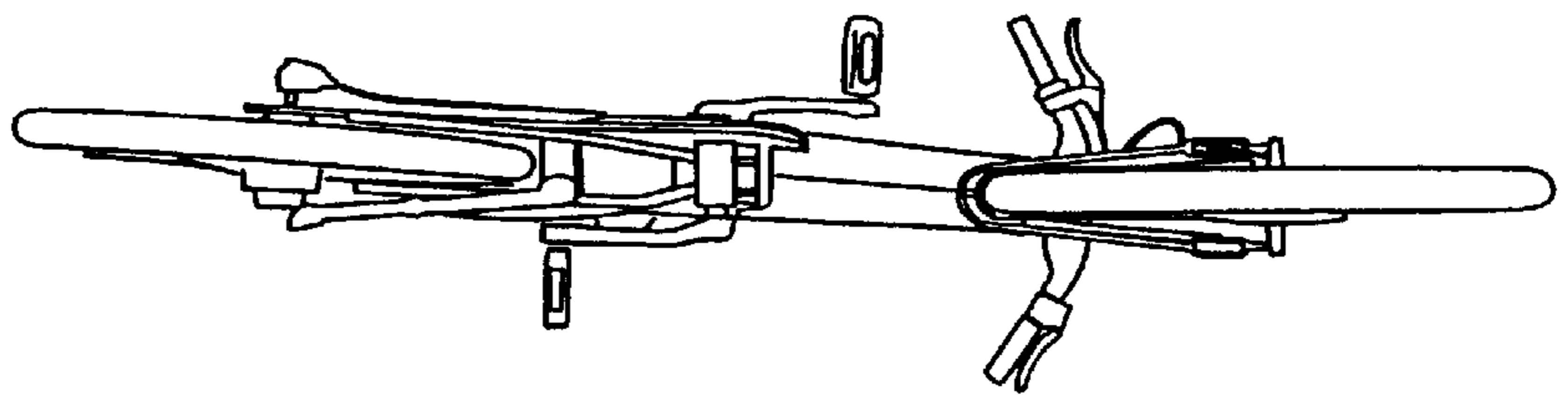

Fig. 12