



US00D465187S

(12) **United States Design Patent**
Walker et al.

(10) **Patent No.:** **US D465,187 S**

(45) **Date of Patent:** **** Nov. 5, 2002**

(54) **CARGO BOX SURFACE**

(75) Inventors: **April Dawn Agee Walker**, Hampton, VA (US); **Dileep Kumar Ticku**, Raleigh, NC (US); **Mark Paul Koontz**, Mayville, WI (US)

(73) Assignee: **Deere & Company**, Moline, IL (US)

(**) Term: **14 Years**

(21) Appl. No.: **29/151,291**

(22) Filed: **Dec. 6, 2001**

(51) **LOC (7) Cl.** **12-06**

(52) **U.S. Cl.** **D12/221**

(58) **Field of Search** D12/221, 93, 98;
296/39.1-39.3, 164, 183; 280/423.1, 433,
441, 441.1, 441.2, 415.1

(56) **References Cited**

U.S. PATENT DOCUMENTS

D249,494 S	9/1978	Lambitz et al.	D12/98
D252,677 S	8/1979	Richardson, III	D12/98
D259,928 S	7/1981	Weis et al.	D12/98
D271,009 S	10/1983	Fishler	D12/98
D293,226 S	12/1987	Whitson	D12/98
D298,112 S	10/1988	Hall	D12/98
D325,716 S	4/1992	Larson	D12/98
D331,896 S	12/1992	Pickering	D12/98
D333,112 S	2/1993	Diaco et al.	D12/98
D339,779 S	9/1993	Spica	D12/155
D346,991 S	5/1994	Krieger, Jr.	D12/98
D350,105 S	8/1994	Schroeder	D12/221
D368,887 S	* 4/1996	Upshaw	D12/221
D371,535 S	* 7/1996	Young	D12/221
D413,854 S	9/1999	Vitoorapakorn	D12/221
D417,182 S	11/1999	Vitoorapakorn	D12/221
5,992,915 A	* 11/1999	Thompson et al.	296/39.2
D425,825 S	* 5/2000	Shambeau et al.	D12/93
6,120,078 A	* 9/2000	Smyl	296/39.1

OTHER PUBLICATIONS

Deere & Company, Gator 6x4 and 4x2 Utility Vehicles, 12 pages, see particularly p. 5, publication date—Mar. 1993, published in U.S.A.

Ransomes America Corporation, Cushman Super Runabout, 2 pages, see particularly p. 2, publication date—1992, published in U.S.A.

(List continued on next page.)

Primary Examiner—Melody N. Brown

(57) **CLAIM**

The ornamental design for a cargo box surface, as shown and described.

DESCRIPTION

FIG. 1 is a left rear elevated perspective view of a cargo box surface showing our new design.

FIG. 2 is a top plan view of the cargo box surface design of FIG. 1.

FIG. 3 is a left side view of the cargo box surface design of FIG. 1.

FIG. 4 is a right side view of the cargo box surface design of FIG. 1.

FIG. 5 is a rear view of the cargo box surface design of FIG. 1.

FIG. 6 is a left rear elevated perspective view of a cargo box surface showing a second embodiment of our new design.

FIG. 7 is a plan view of the cargo box surface design of FIG. 6.

FIG. 8 is a left side view of the cargo box surface design of FIG. 6.

FIG. 9 is a right side view of the cargo box surface design of FIG. 6; and,

FIG. 10 is a rear view of the cargo box surface design of FIG. 6.

The broken lines shown in FIGS. 1, 2, 6, and 7 are shown for illustrative purposes and form no part of the claimed design.

1 Claim, 4 Drawing Sheets

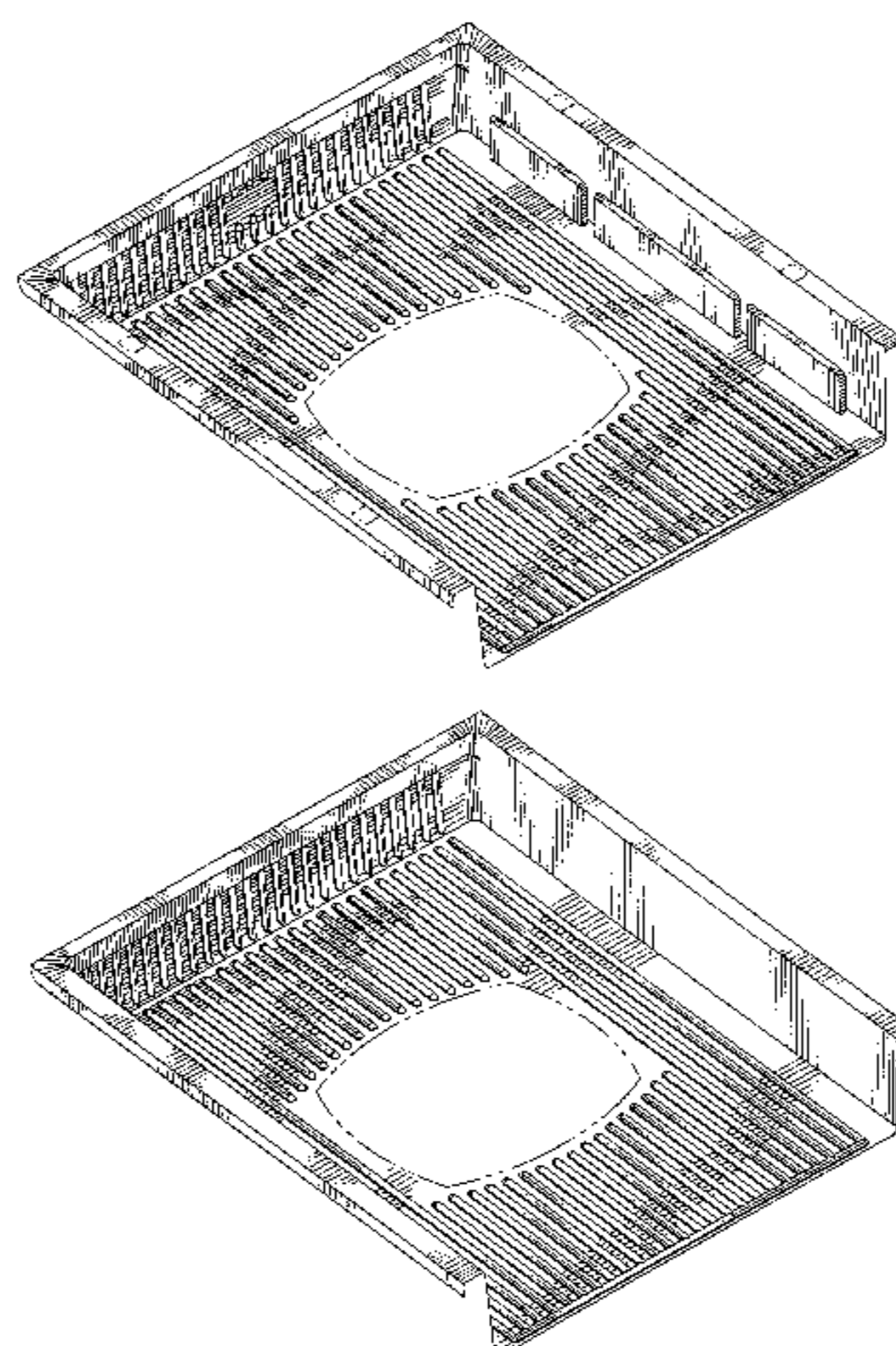

OTHER PUBLICATIONS

Daihatsu America Inc., Daihatsu Multipurpose Off-Road Utility Vehicle, 12 pages, see particularly p. 10, publication date—1988, published in U.S.A.

Yamaha Motor Corp., U.S.A., Yamaha Utility Review, 4 pages, see particularly p. 1, publication date—Feb. 1989, published in U.S.A.

Outboard Marine Corporation, Cushman Turf-Care Vehicles and Accessories, 20 pages, see particularly p. 19, publication date—1987, published in U.S.A.

Kawasaki Motors Corp., U.S.A., Mule Accessories Catalog, 16 pages, see particularly p. 10, publication date—1993, published in U.S.A.

* cited by examiner

Fig. 1

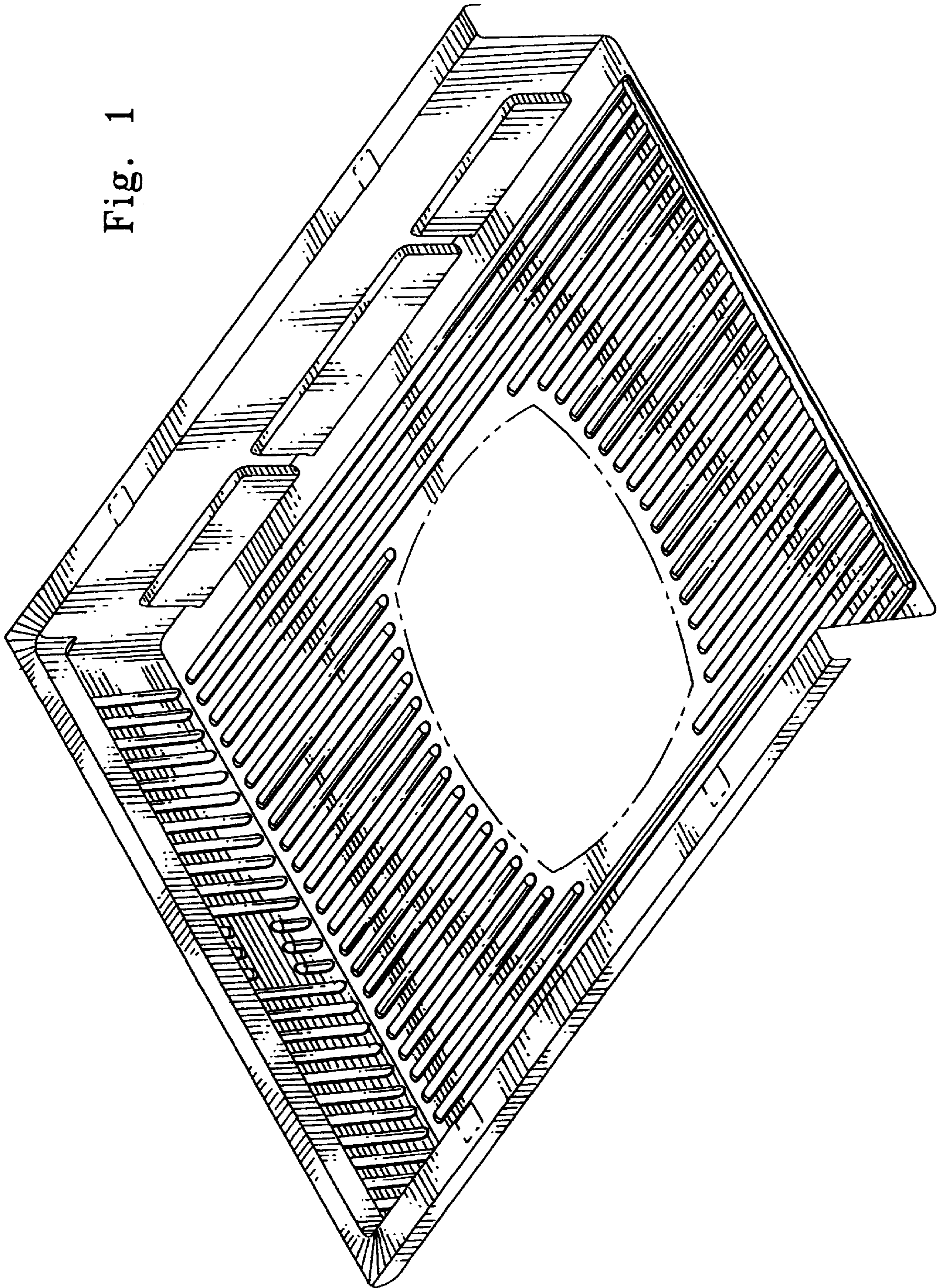

Fig. 2

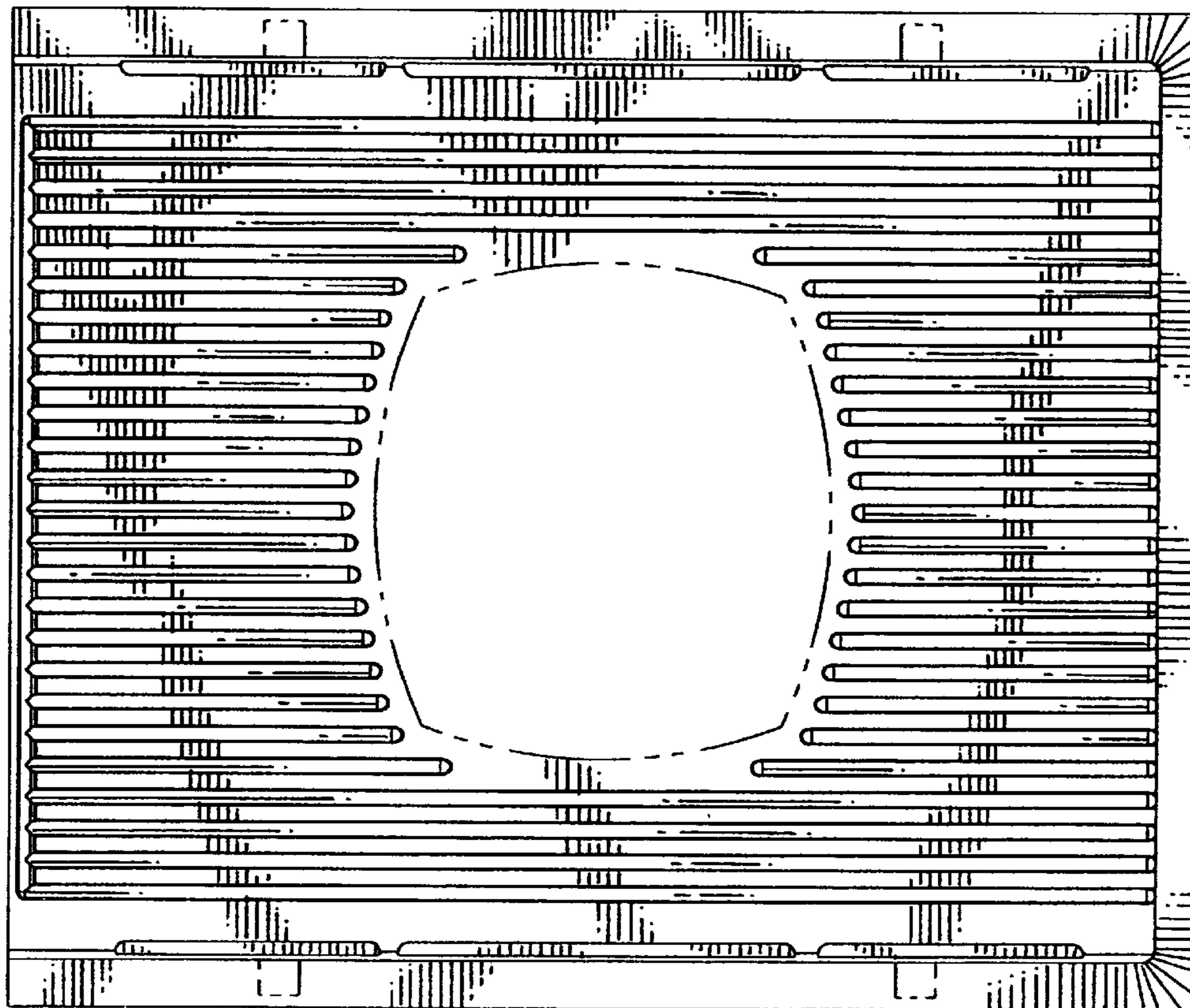

Fig. 3

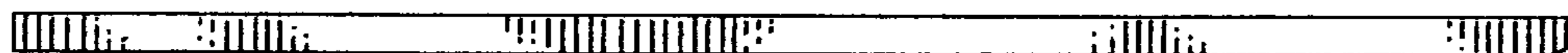

Fig. 4

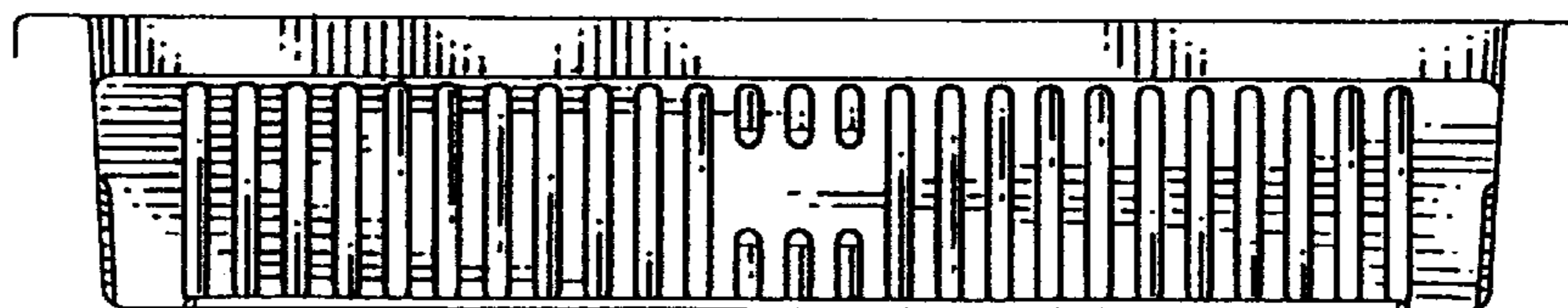

Fig. 5

Fig. 6

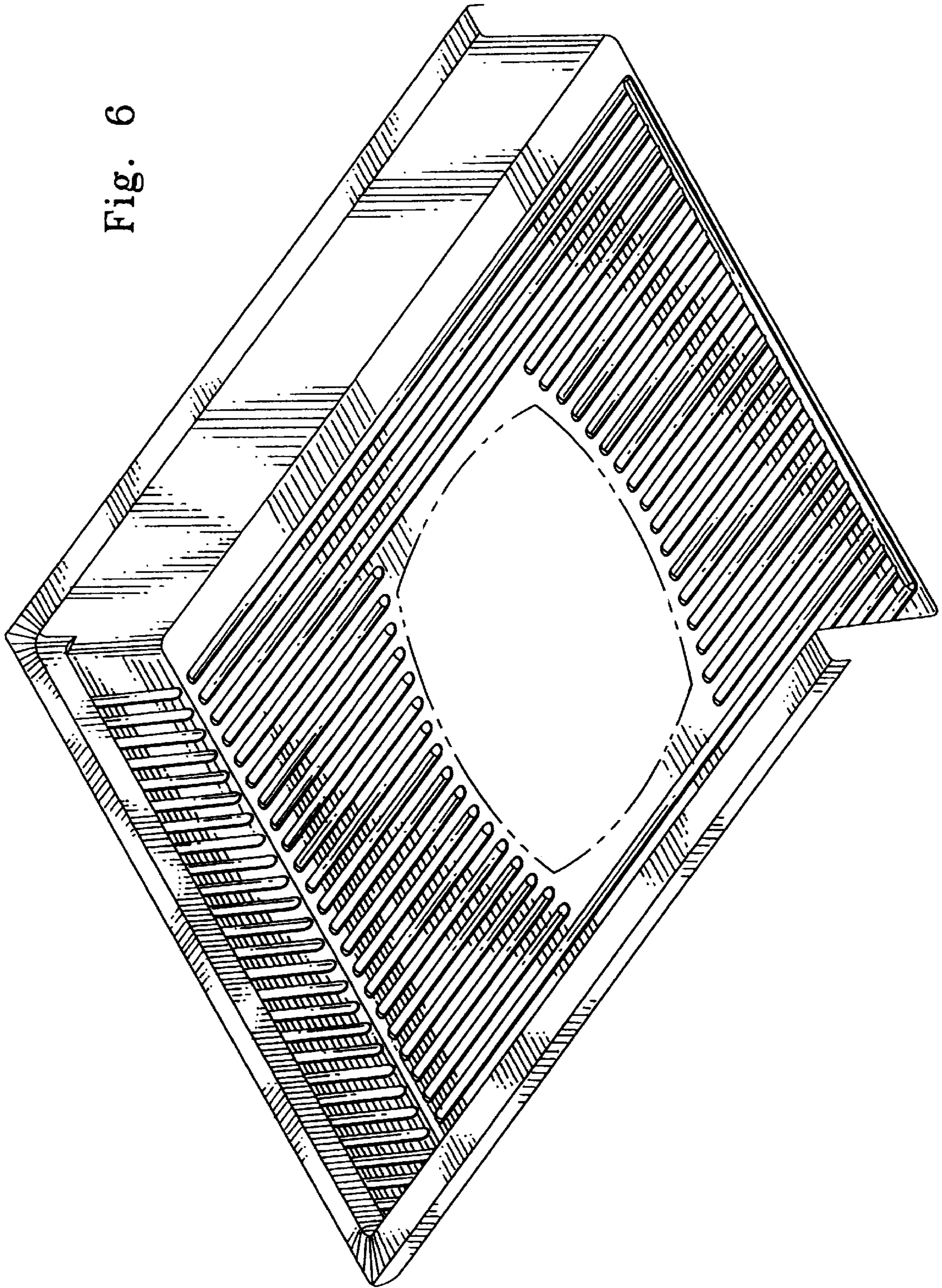

Fig. 7

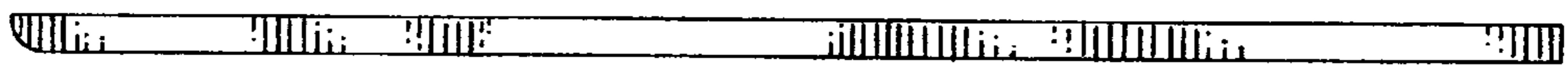
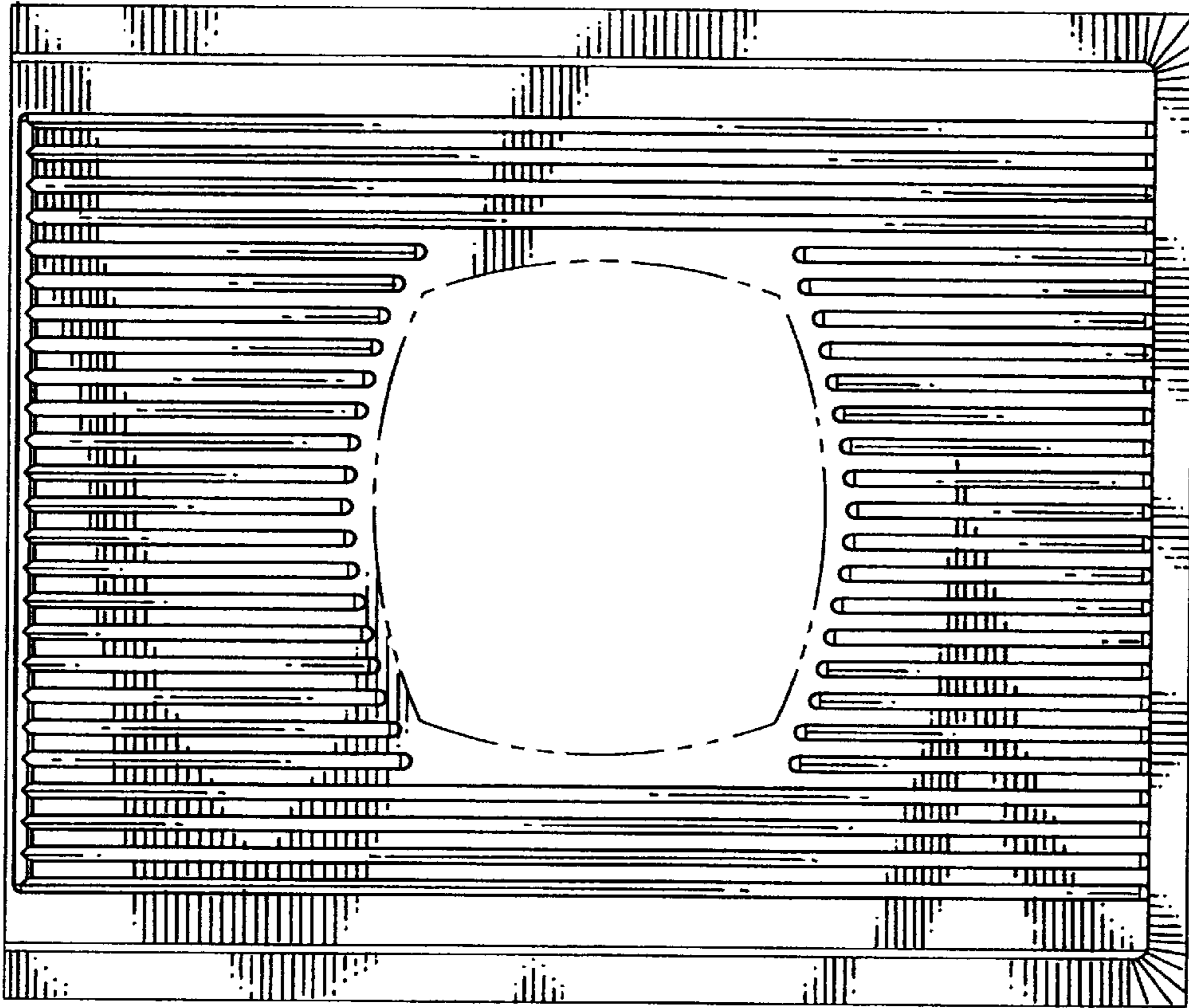

Fig. 8



Fig. 9

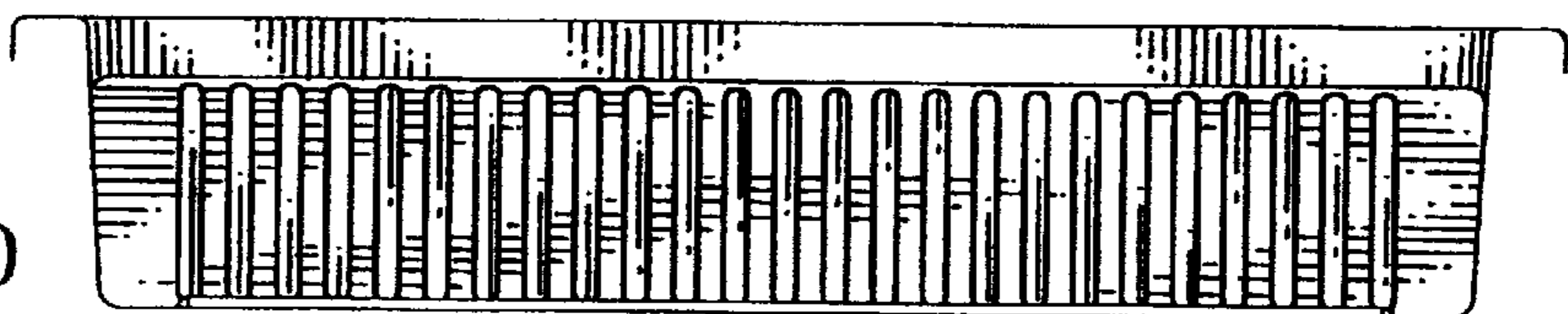

Fig. 10