



US00D465020S

(12) **United States Design Patent**
Stone et al.

(10) **Patent No.:** **US D465,020 S**

(45) **Date of Patent:** **** Oct. 29, 2002**

(54) **STOCK CAR AIR FRESHENER FOR MOTOR VEHICLES**

(75) Inventors: **Robert D. Stone**, Castle Rock, CO (US); **Frank N. Cane**, San Jose, CA (US)

(73) Assignee: **FatBoy Fresh, Inc.**, San Jose, CA (US)

(**) Term: **14 Years**

(21) Appl. No.: **29/162,269**

(22) Filed: **Jun. 12, 2002**

(51) **LOC (7) Cl.** **23-04**

(52) **U.S. Cl.** **D23/366**

(58) **Field of Search** D23/366-369;
239/60, 211, 55, 53, 57, 34, 52; 261/DIG. 65;
422/305, 120, 5; D21/548-560, 424-435;
D12/90-92, 86

(56) **References Cited**

U.S. PATENT DOCUMENTS

D347,886 S	6/1994	Bender	
D373,626 S	9/1996	Dente et al.	
D385,344 S	10/1997	Green	
D390,433 S	* 2/1998	Miller	81/3.4
D390,942 S	2/1998	Mei	
D396,528 S	7/1998	Ceresko	
D398,047 S	* 9/1998	Chen	D23/366
D398,390 S	9/1998	Chen	
D398,976 S	9/1998	Green	
D403,420 S	12/1998	Vullion	
5,865,372 A	2/1999	Ceresko	
D408,456 S	* 4/1999	Garner	D19/86
D413,970 S	9/1999	Chen	
D415,800 S	* 10/1999	Norton	D21/548
D417,729 S	12/1999	Chen	
D419,207 S	* 1/2000	Lieberman	D21/548

D419,659 S	1/2000	Yang	
6,123,906 A	9/2000	Farmer	
D431,862 S	10/2000	Chen	
D435,898 S	* 1/2001	Yang	D23/367
D439,321 S	3/2001	Matthew et al.	
6,305,685 B1	* 10/2001	Motosko	273/118 R

* cited by examiner

Primary Examiner—Lisa Lichtenstein

(57) **CLAIM**

The ornamental design for a stock car air freshener for motor vehicles, as shown and described.

DESCRIPTION

FIG. 1 is a perspective view of a stock car air freshener, showing our new design.

FIG. 2 is a perspective view of a stock car air freshener for motor vehicles, showing a second embodiment of our new design;

FIG. 3 is a front elevational view thereof;

FIG. 4 is a rear elevational view thereof;

FIG. 5 is a left side elevational view thereof;

FIG. 6 is a right side elevational view thereof;

FIG. 7 is a top plan view thereof;

FIG. 8 is a bottom plan view thereof;

FIG. 9 is an alternative bottom plan view thereof; and,

FIG. 10 is a perspective view of a stock car air freshener for motor vehicles on a reduced scale shown in use. The broken line showing of environmental structure is for illustrative purposes only and forms no part of the claimed design.

The sole difference between the first and second embodiments resides in the location of the clip which is on the right side in the first embodiment and on the left side in the second embodiment. The sole difference between the third embodiment and the first two embodiments resides in the lack of a clip.

1 Claim, 10 Drawing Sheets

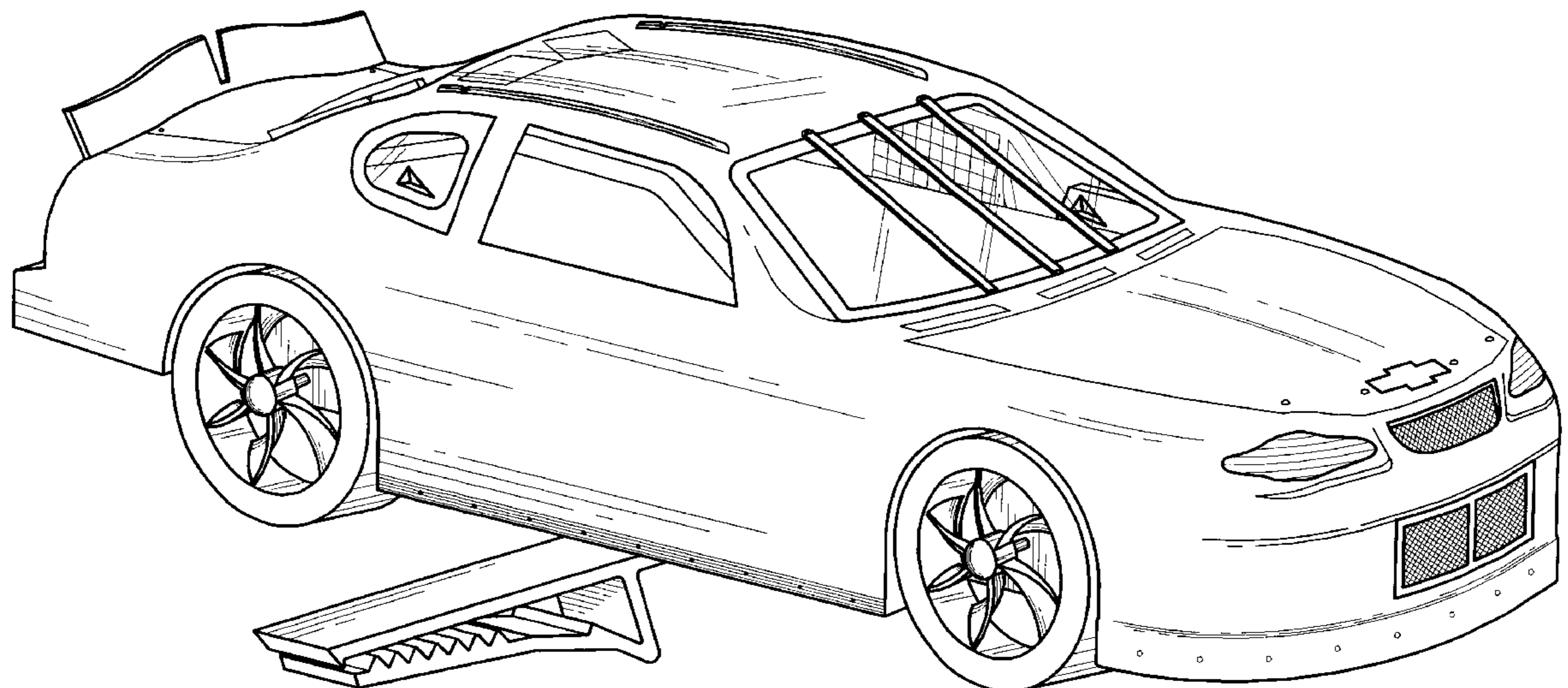

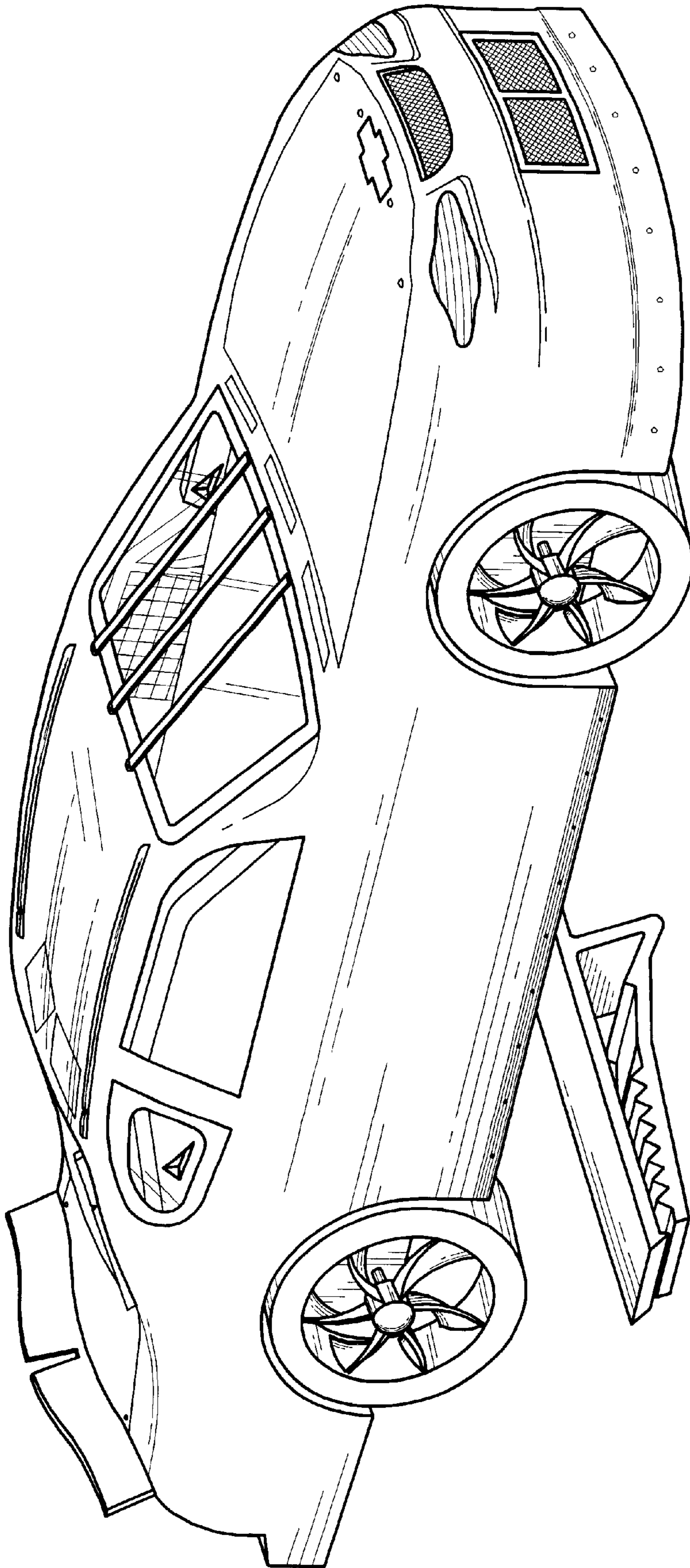

FIG. 1

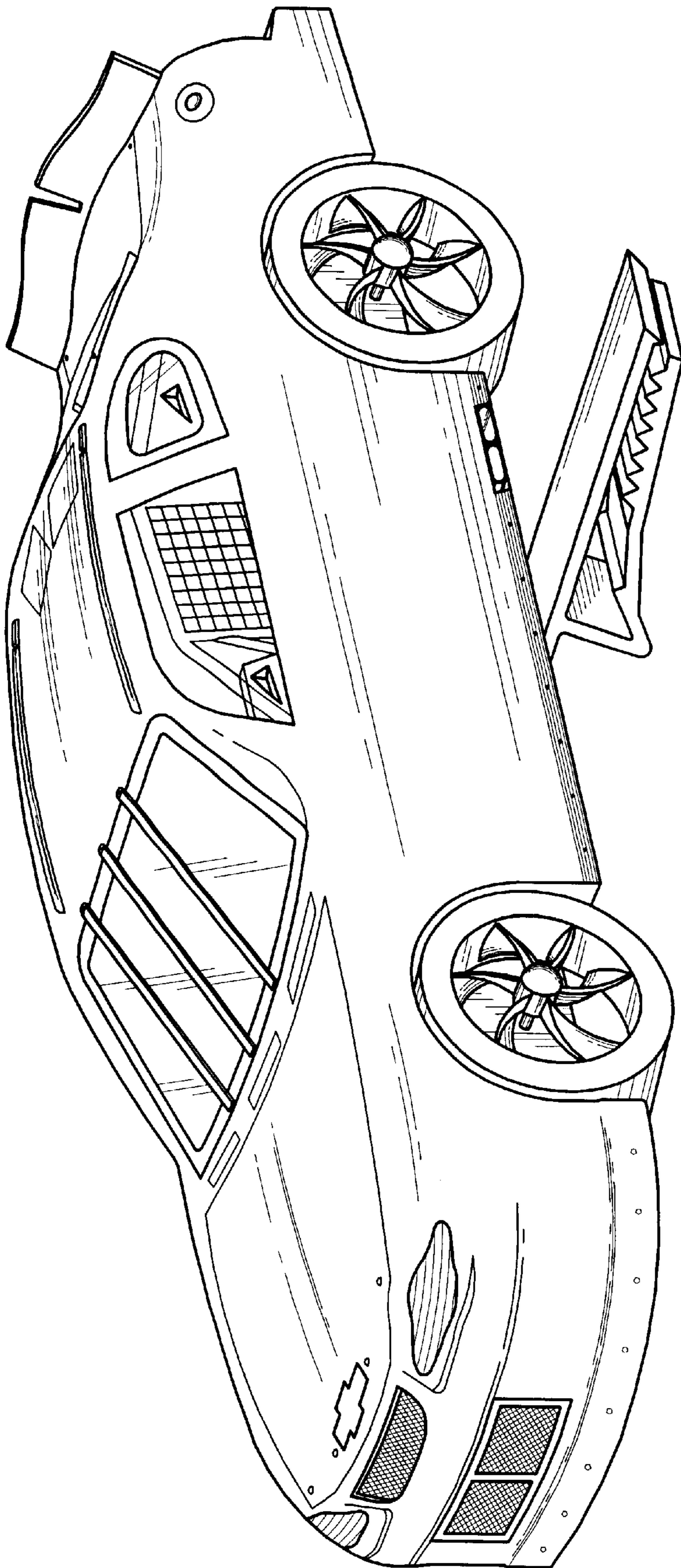

FIG. 2

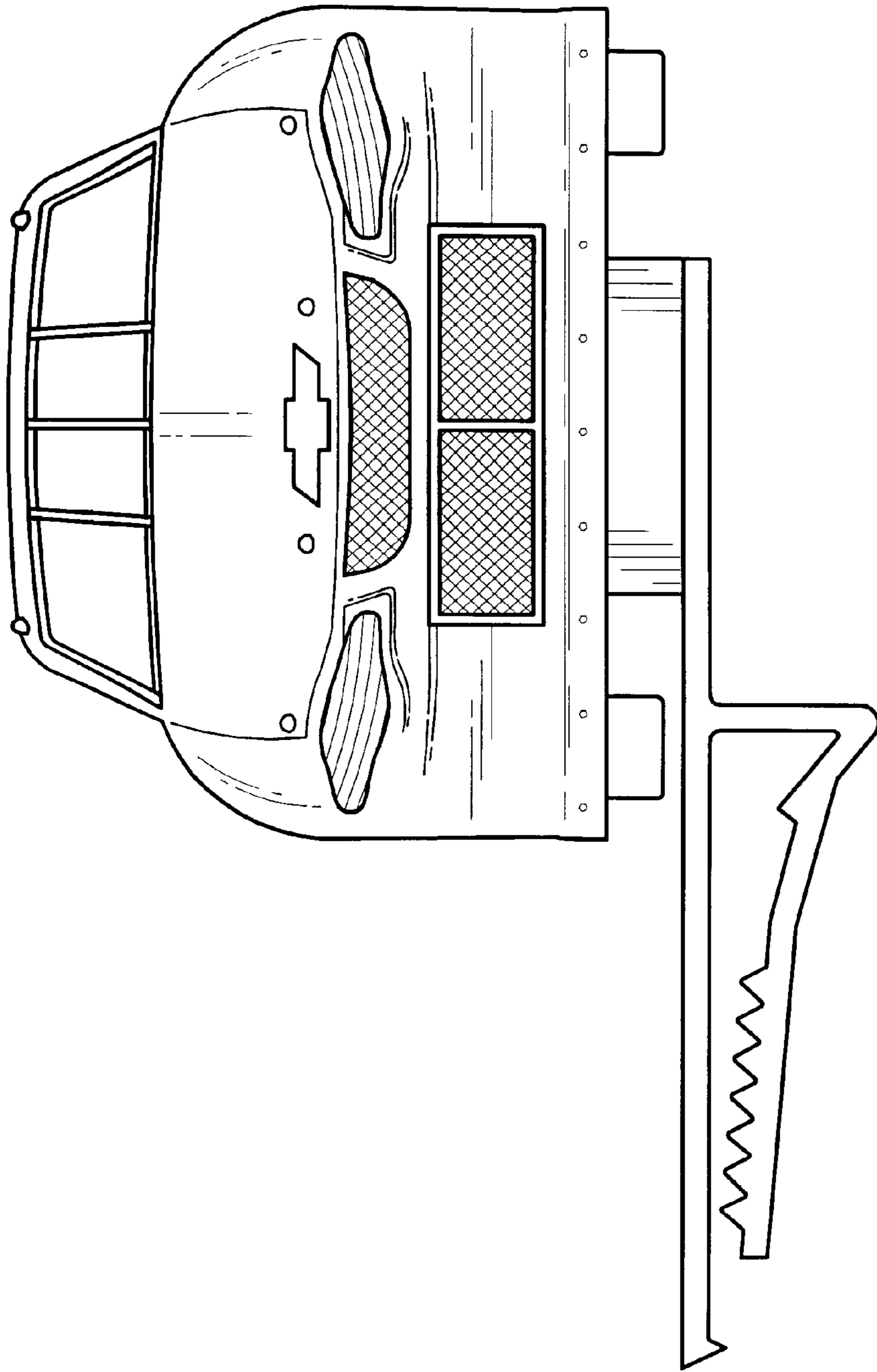

FIG. 3

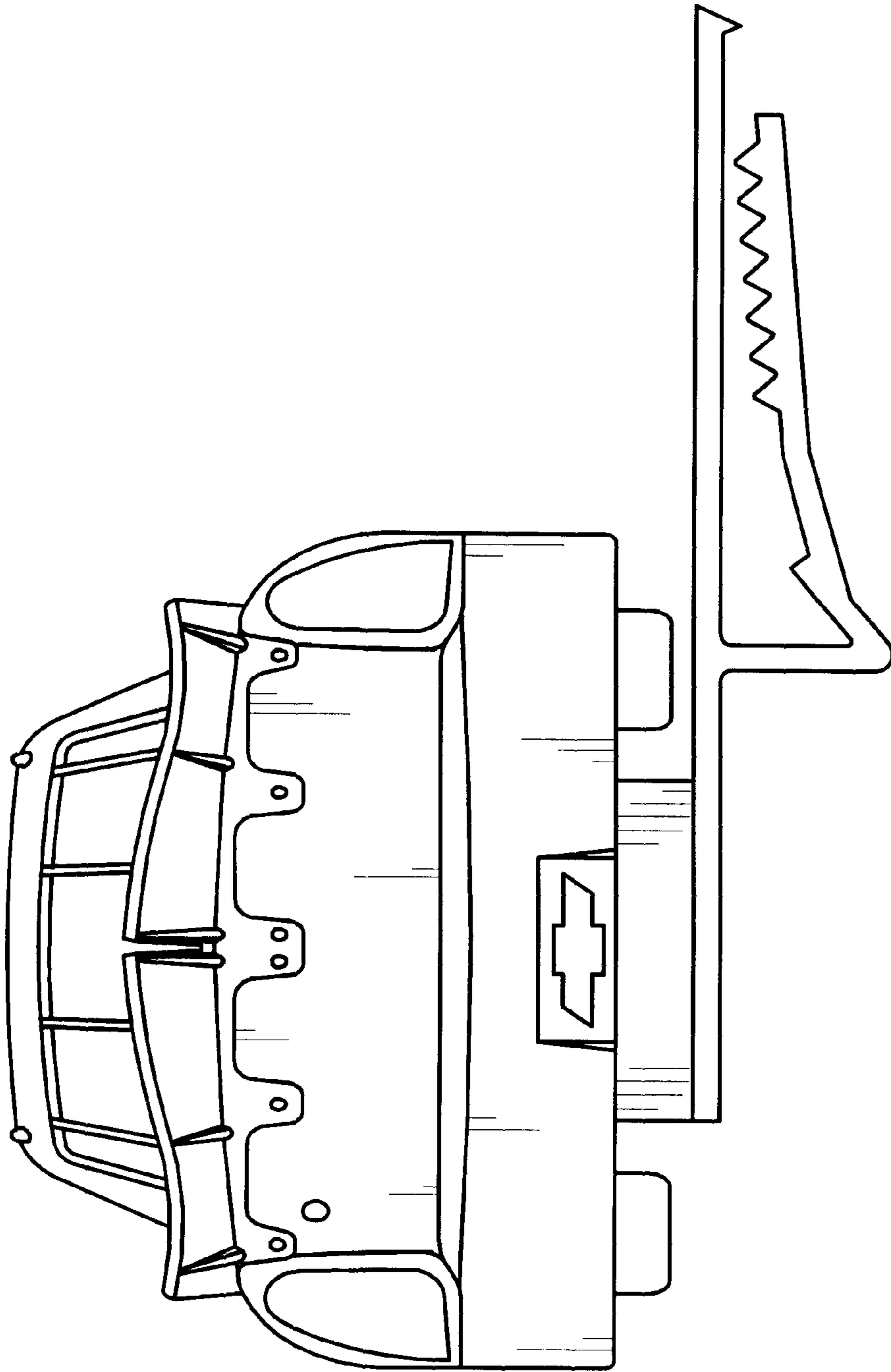

FIG. 4

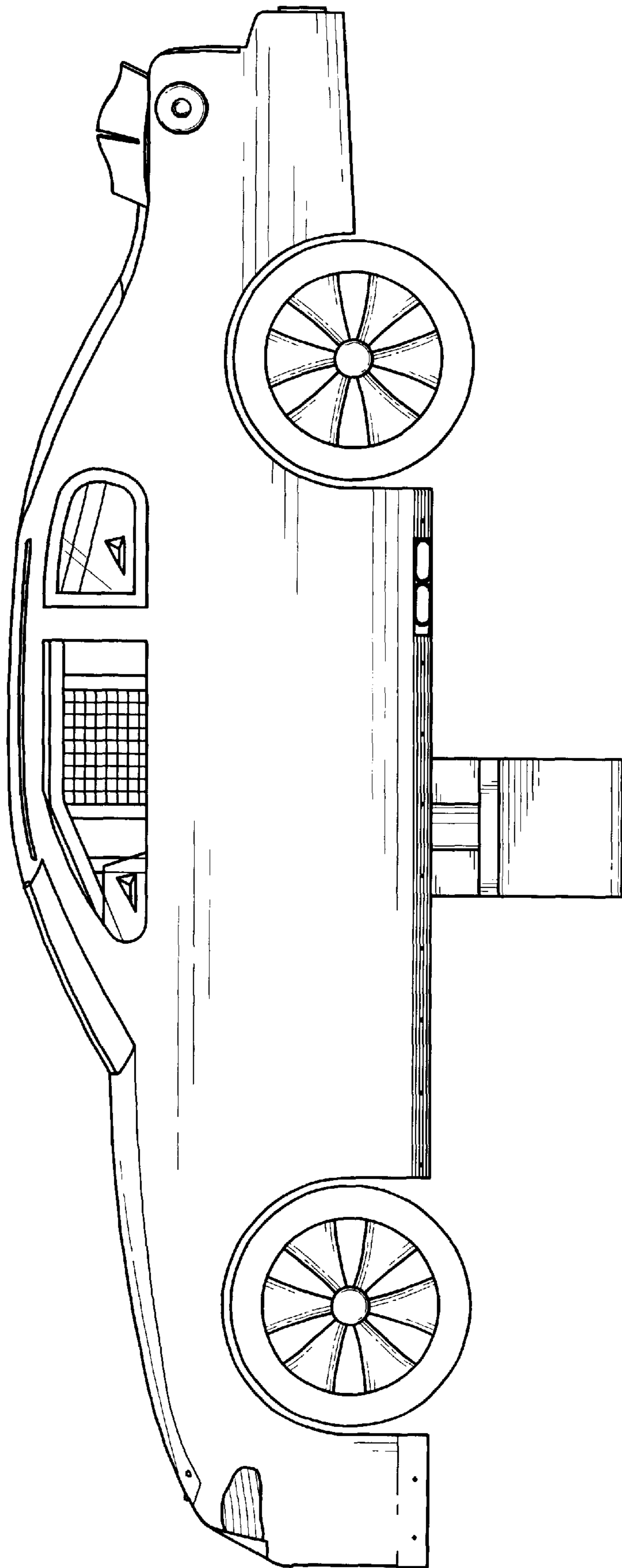

FIG. 5

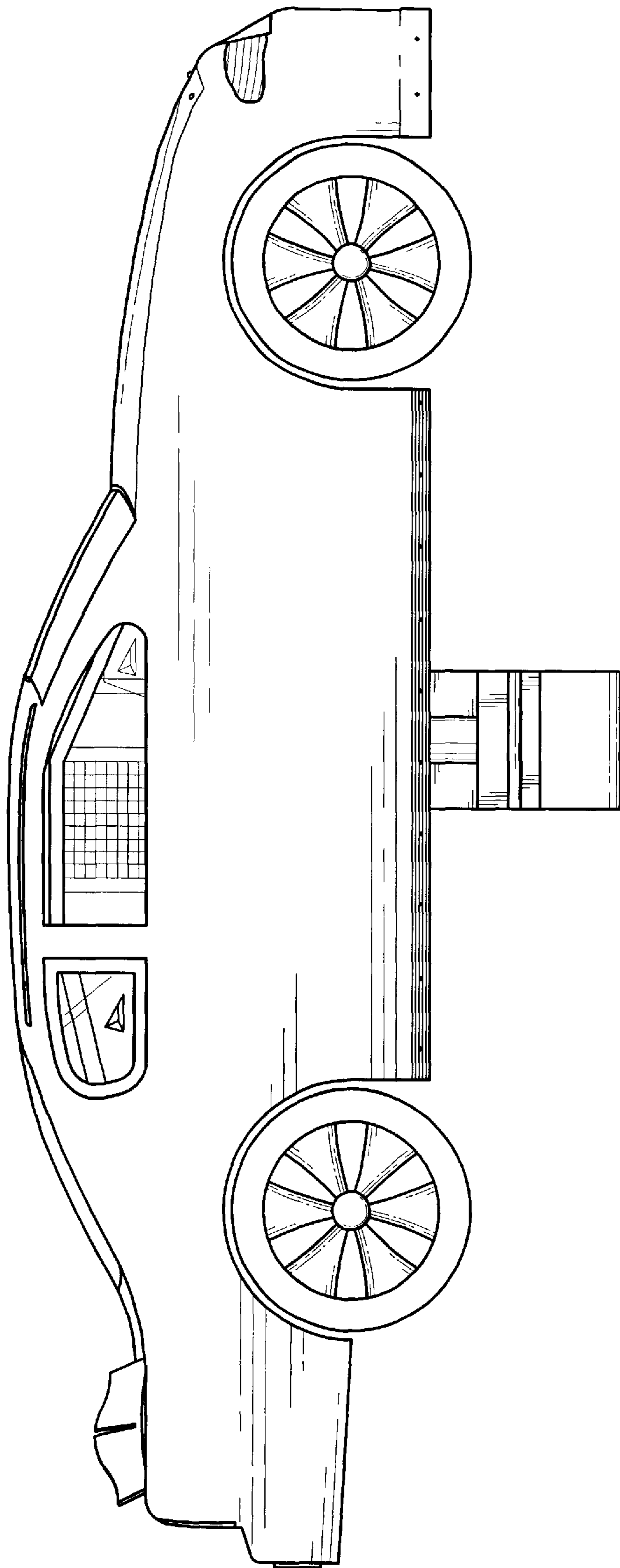

FIG. 6

FIG. 7

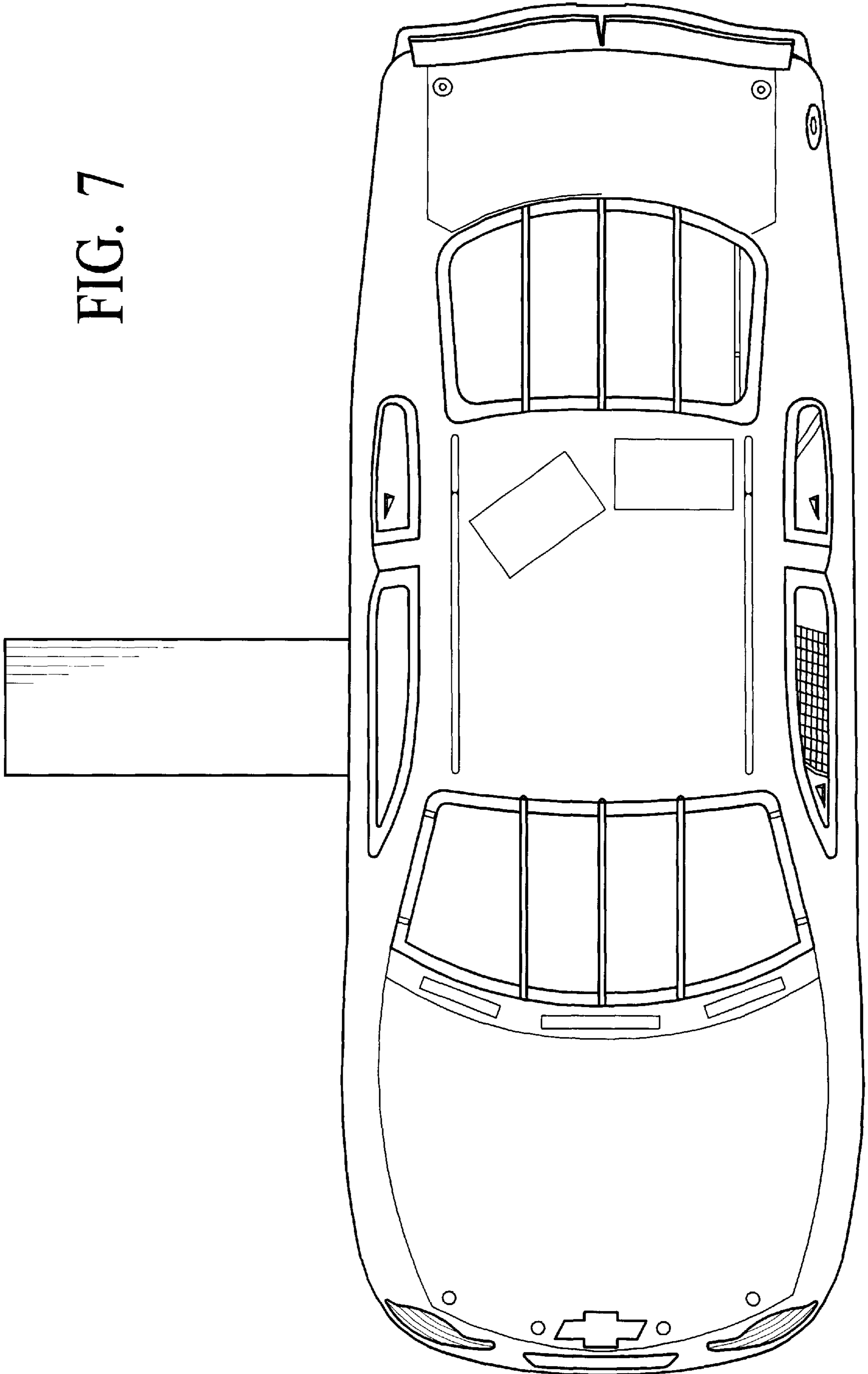
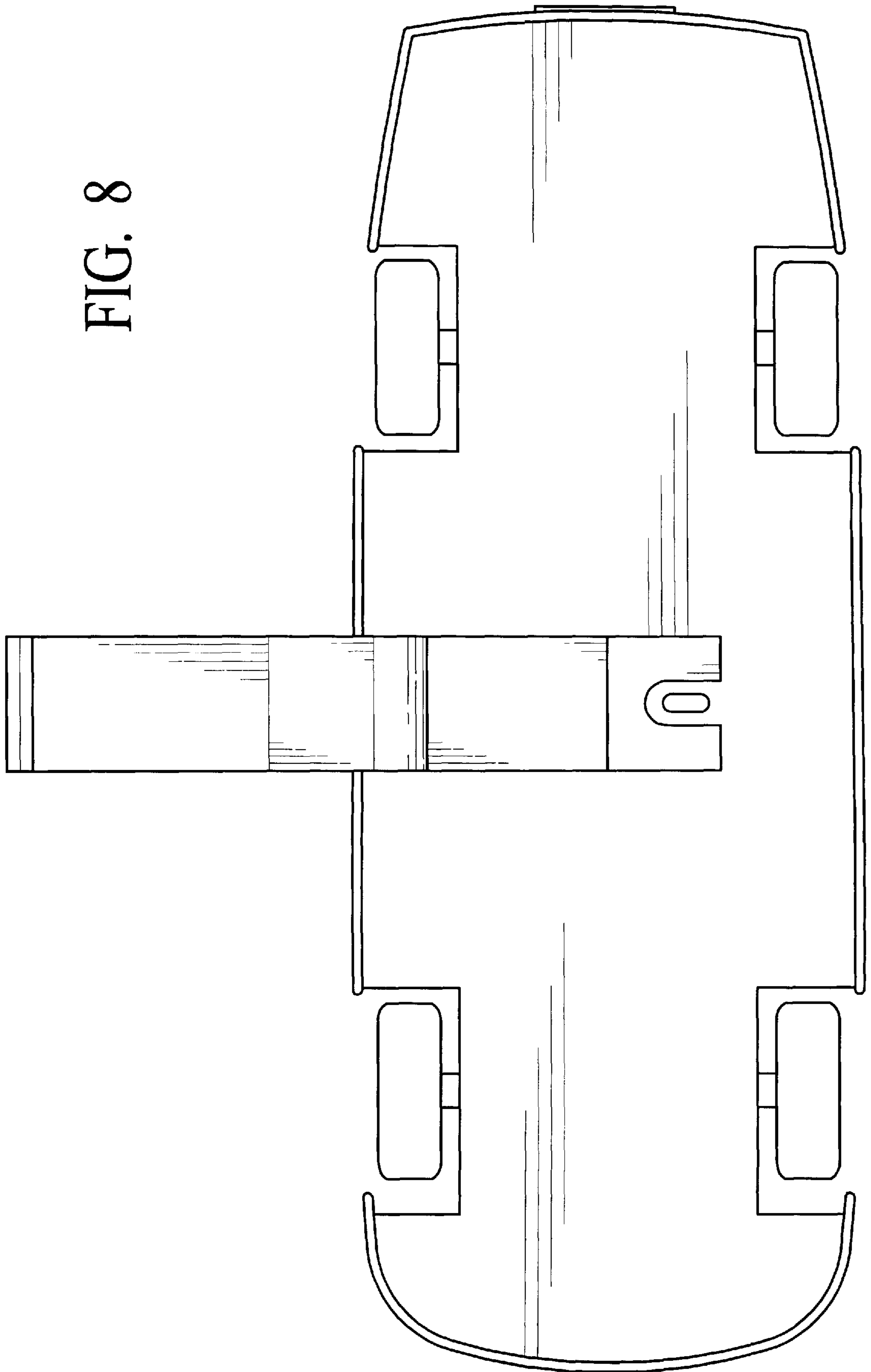

FIG. 8



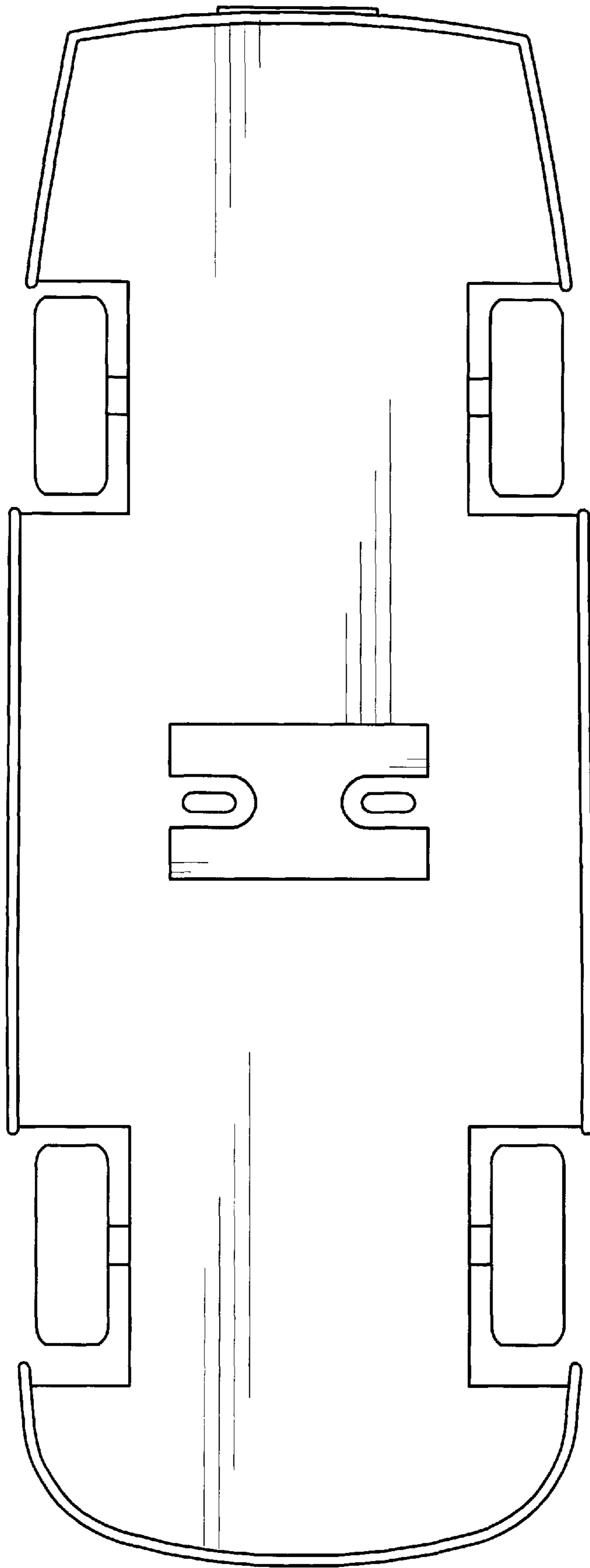

FIG. 9

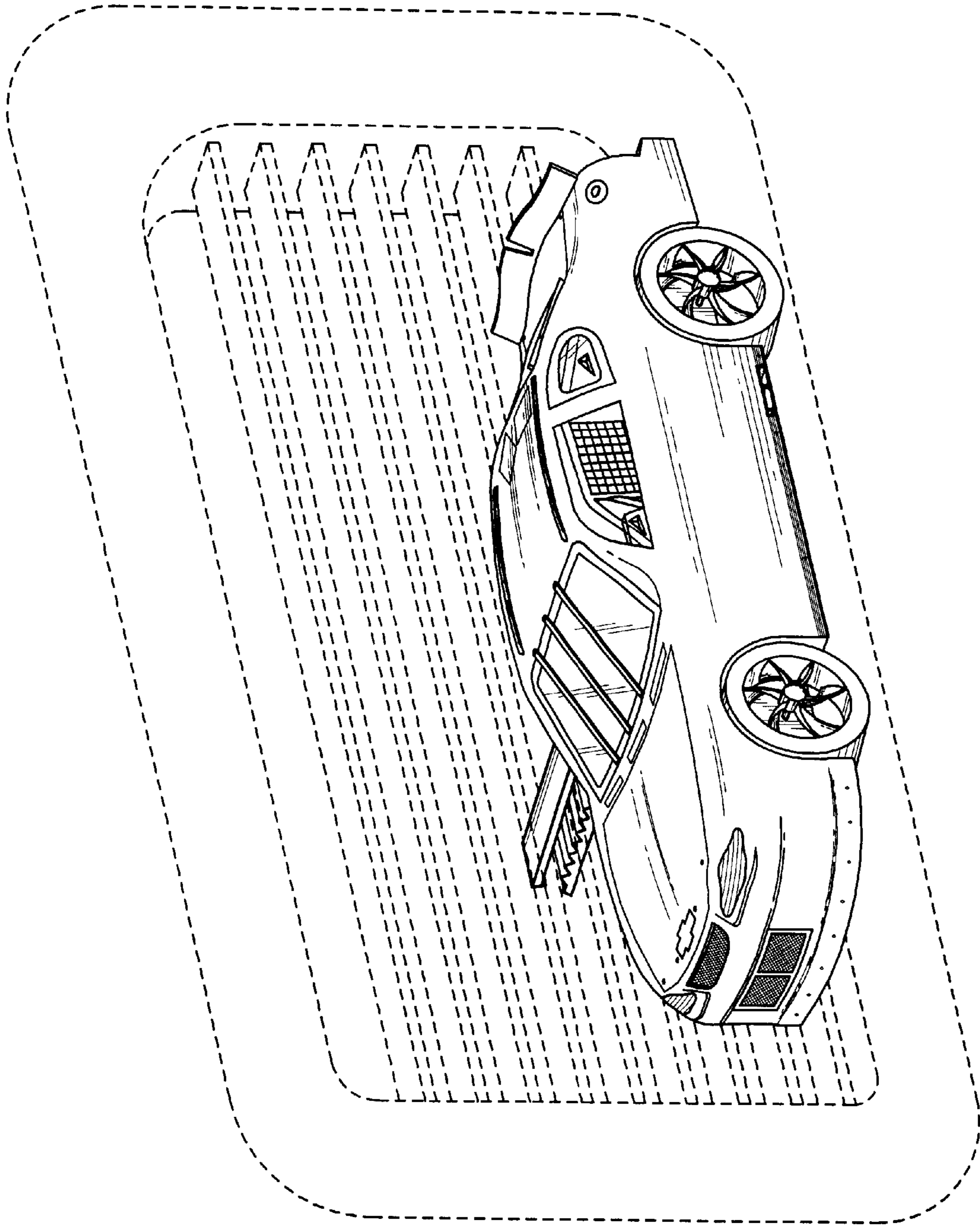

FIG. 10