



US00D464976S

(12) **United States Design Patent**  
**Krieger et al.**

(10) **Patent No.:** **US D464,976 S**

(45) **Date of Patent:** **\*\* Oct. 29, 2002**

(54) **RECHARGEABLE HANDHELD COMPRESSOR**

(75) Inventors: **Michael Krieger**, Miami Beach, FL (US); **Kevin Ellsworth**, Hollywood, FL (US)

(73) Assignee: **Vector Products, Inc.**, Ft. Lauderdale, FL (US)

(\*\*) Term: **14 Years**

(21) Appl. No.: **29/158,157**

(22) Filed: **Apr. 1, 2002**

(51) **LOC (7) Cl.** ..... **15-02**

(52) **U.S. Cl.** ..... **D15/9**

(58) **Field of Search** ..... D15/7-9; 417/234, 417/231, 410.4; D21/59

(56) **References Cited**

**U.S. PATENT DOCUMENTS**

- D248,396 S \* 7/1978 Sendak ..... D15/7
- D400,892 S \* 11/1998 Williams ..... D15/9

- D415,500 S \* 10/1999 Poon ..... D15/7
- D421,756 S \* 3/2000 Bonzer ..... D15/7
- D423,519 S \* 4/2000 Bonzer ..... D15/9
- D451,521 S \* 12/2001 Poon ..... D15/7

\* cited by examiner

*Primary Examiner*—Ralf Seifert

(74) *Attorney, Agent, or Firm*—Venable; Robert Kinberg

(57) **CLAIM**

The ornamental design for a rechargeable handheld compressor, as shown and described.

**DESCRIPTION**

FIG. 1 is a top-front-left perspective view of the rechargeable handheld compressor showing our new design; FIG. 2 is a front view of the design shown in FIG. 1; FIG. 3 is a back view of the design shown in FIG. 1; FIG. 4 is a left side view of the design shown in FIG. 1; FIG. 5 is a right side view of the design shown in FIG. 1; FIG. 6 is a top view of the design shown in FIG. 1; and, FIG. 7 is a bottom view of the design shown in FIG. 1.

**1 Claim, 5 Drawing Sheets**

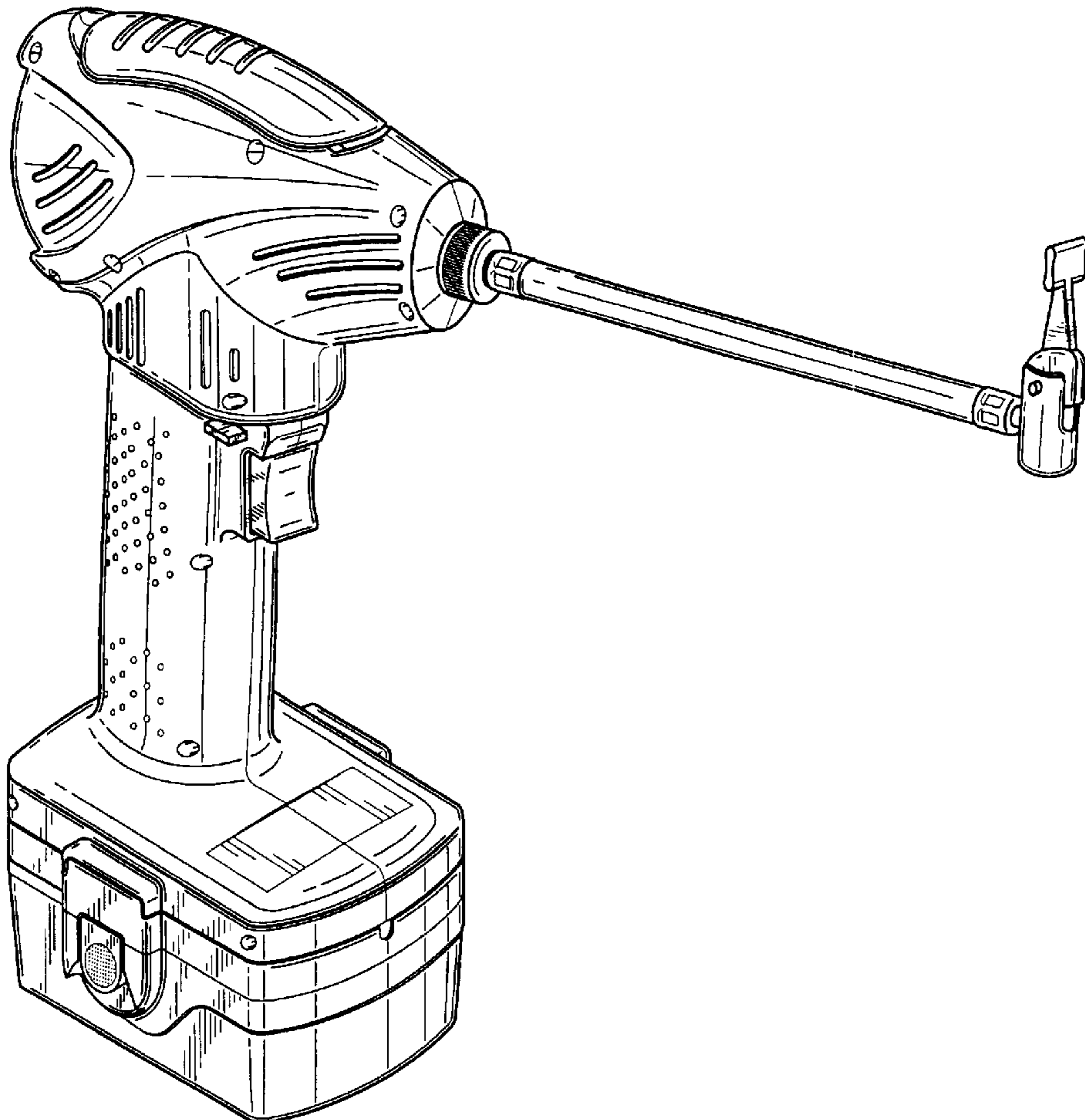

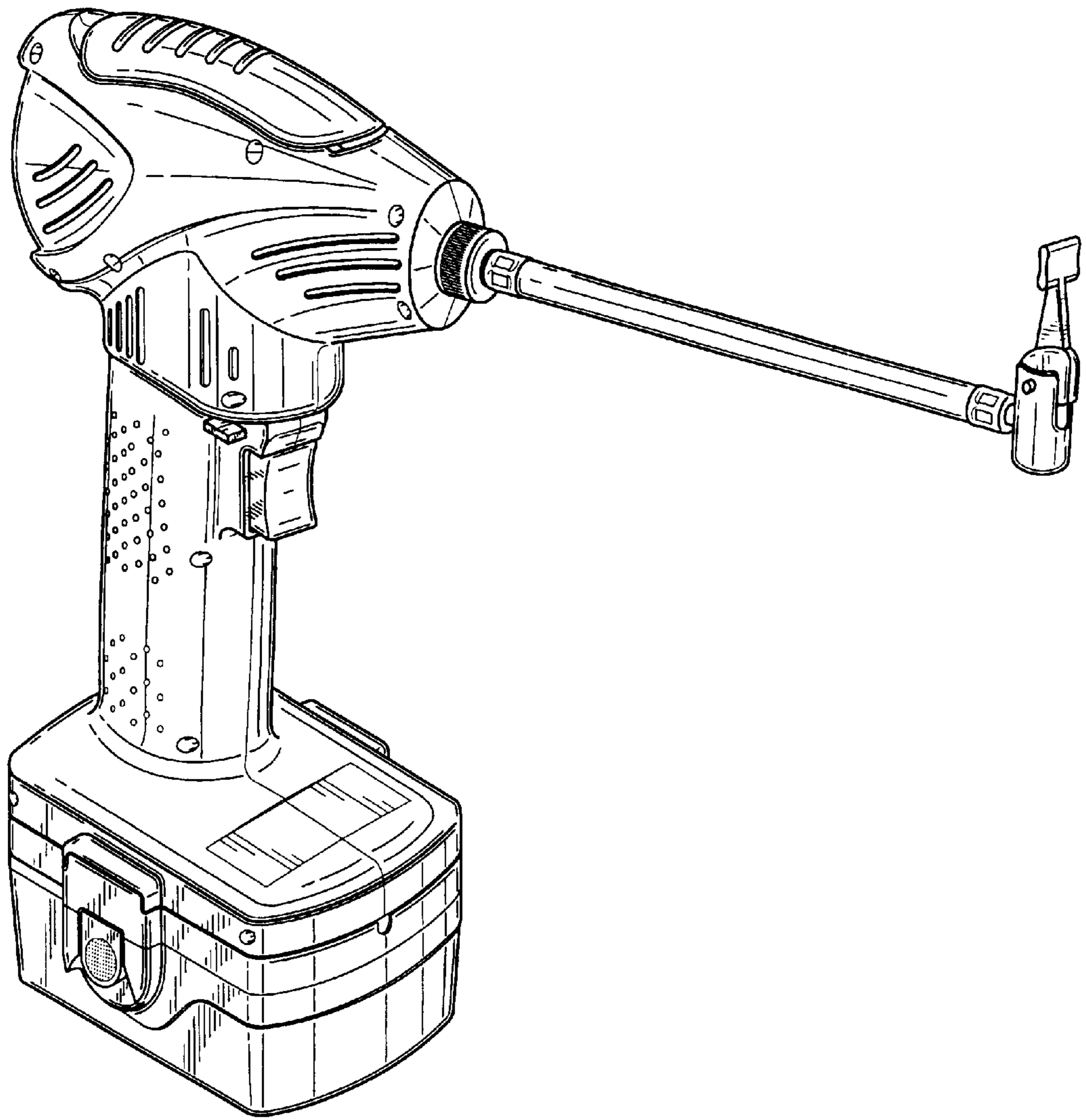

FIG. 1

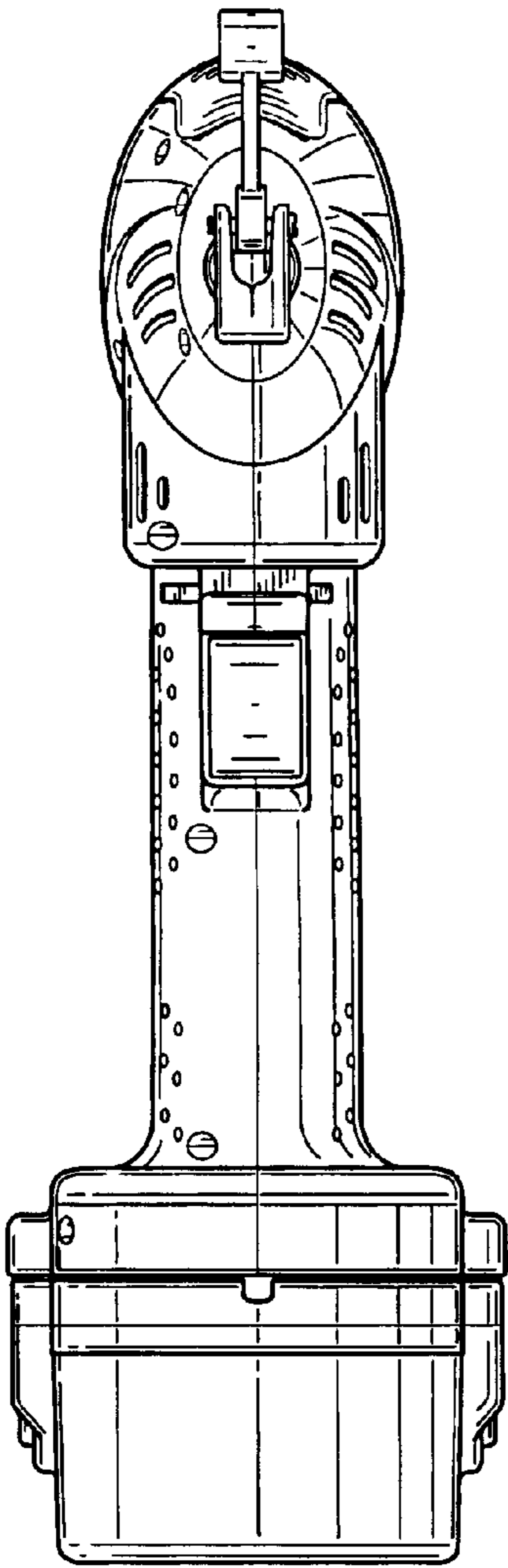

FIG. 2

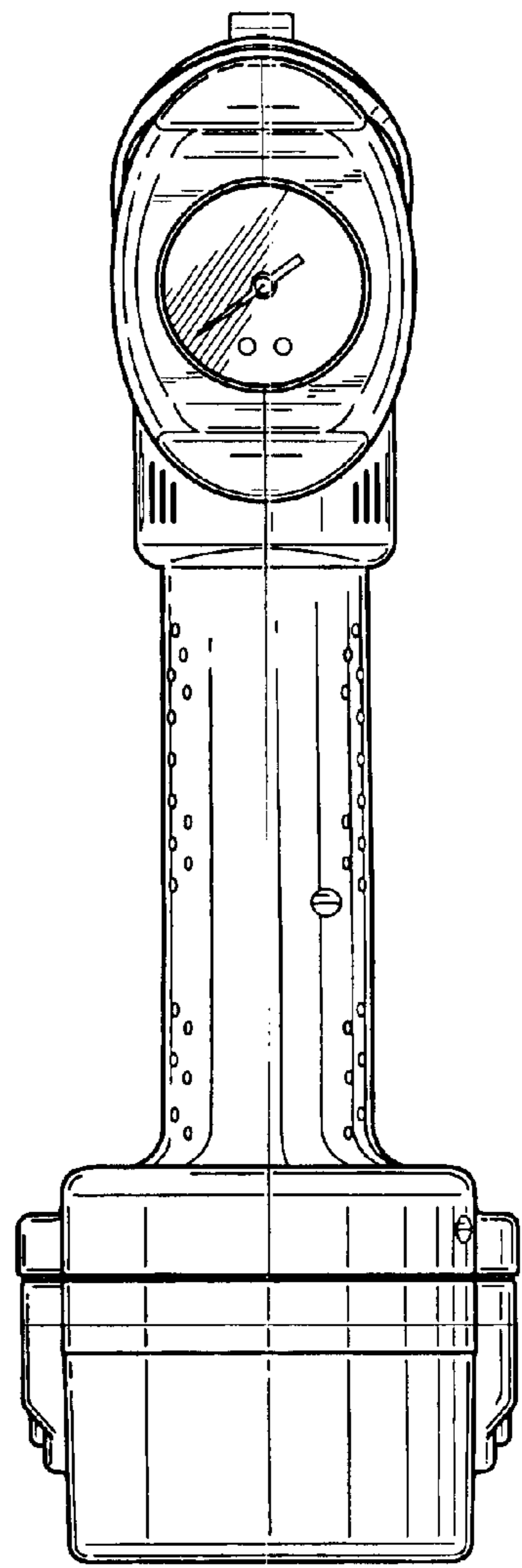

FIG. 3

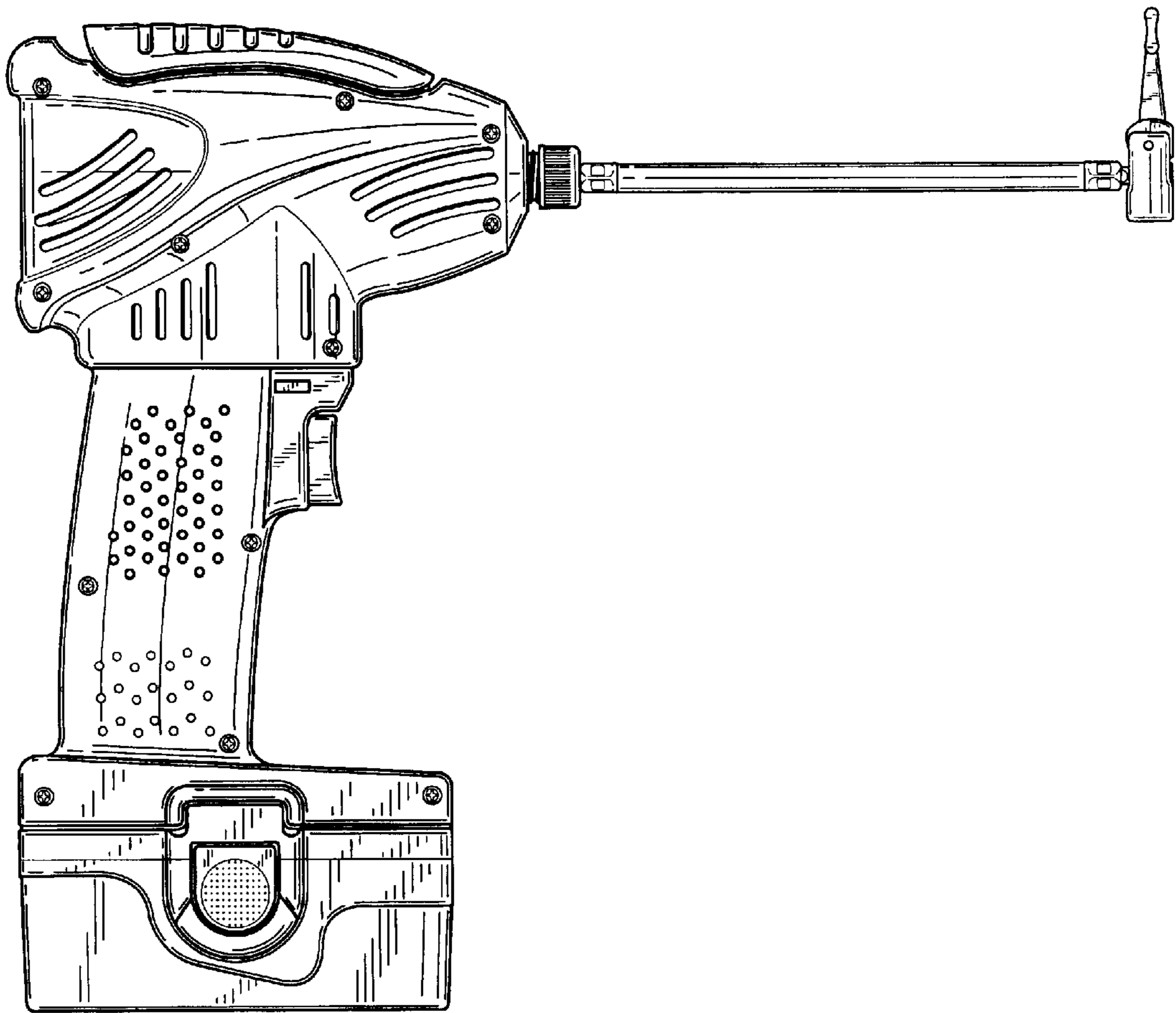

FIG. 4

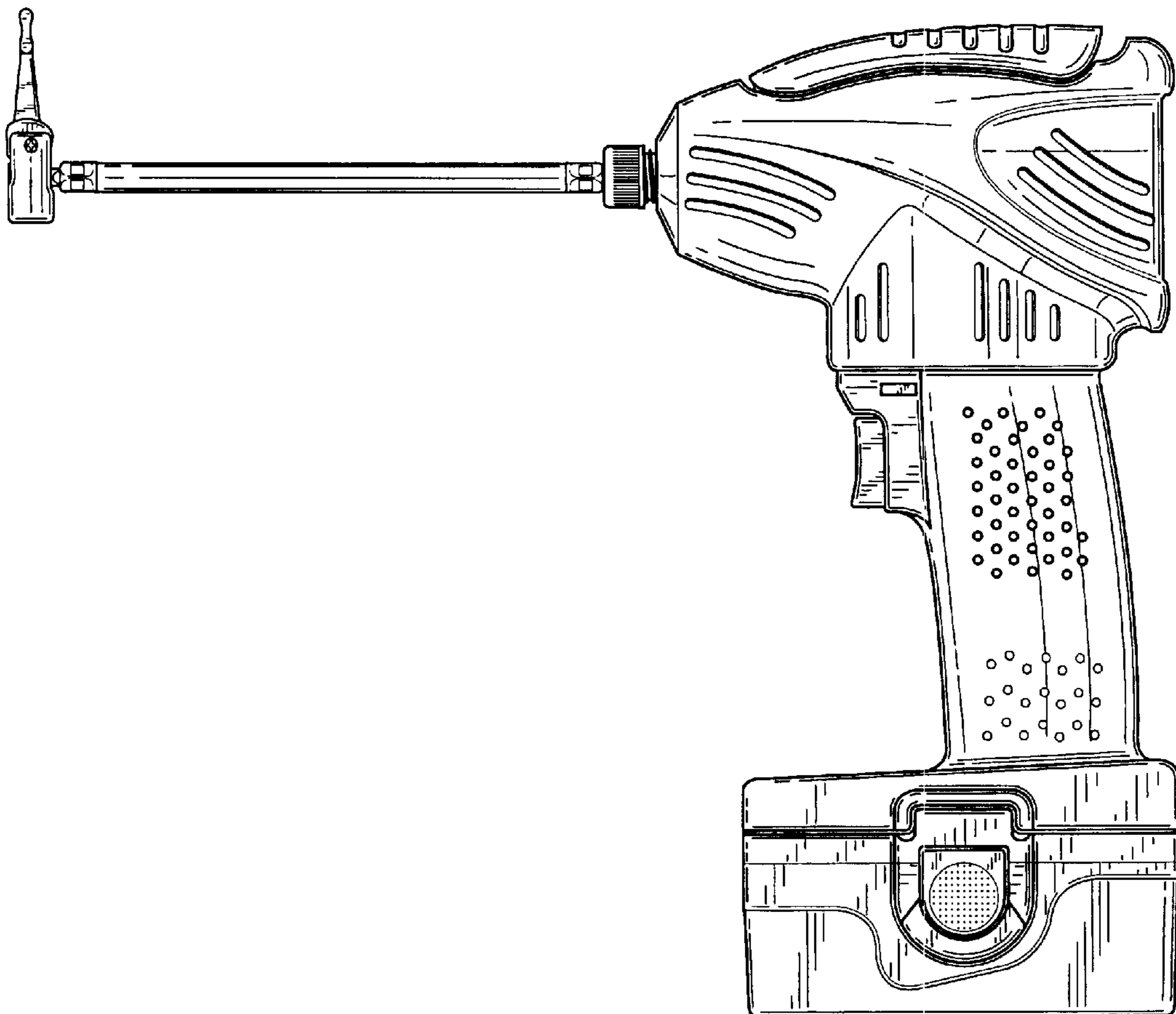

FIG. 5

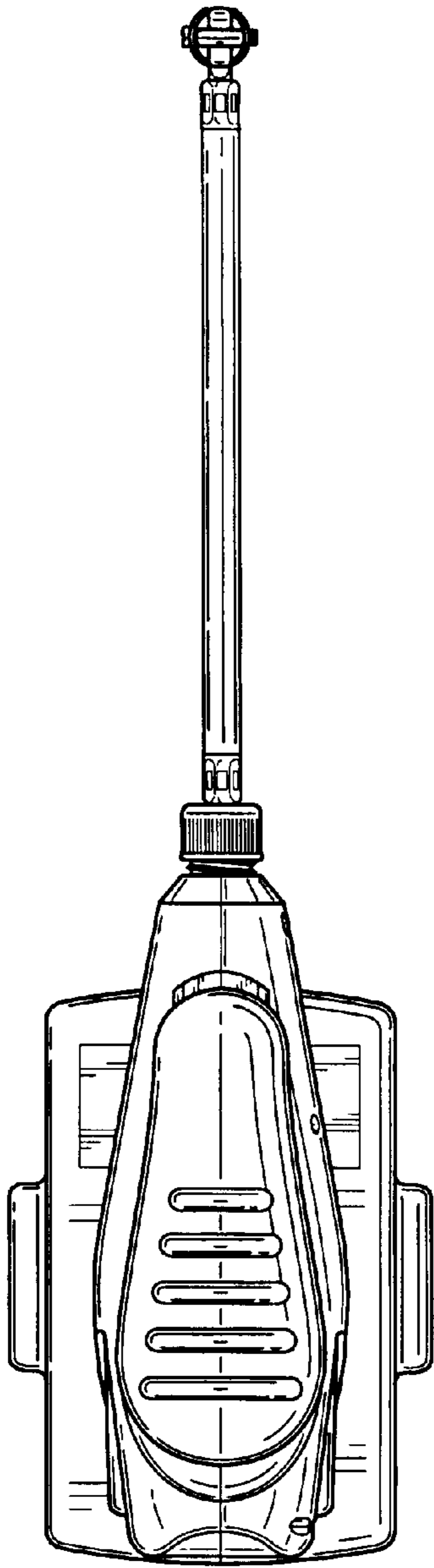

FIG. 6

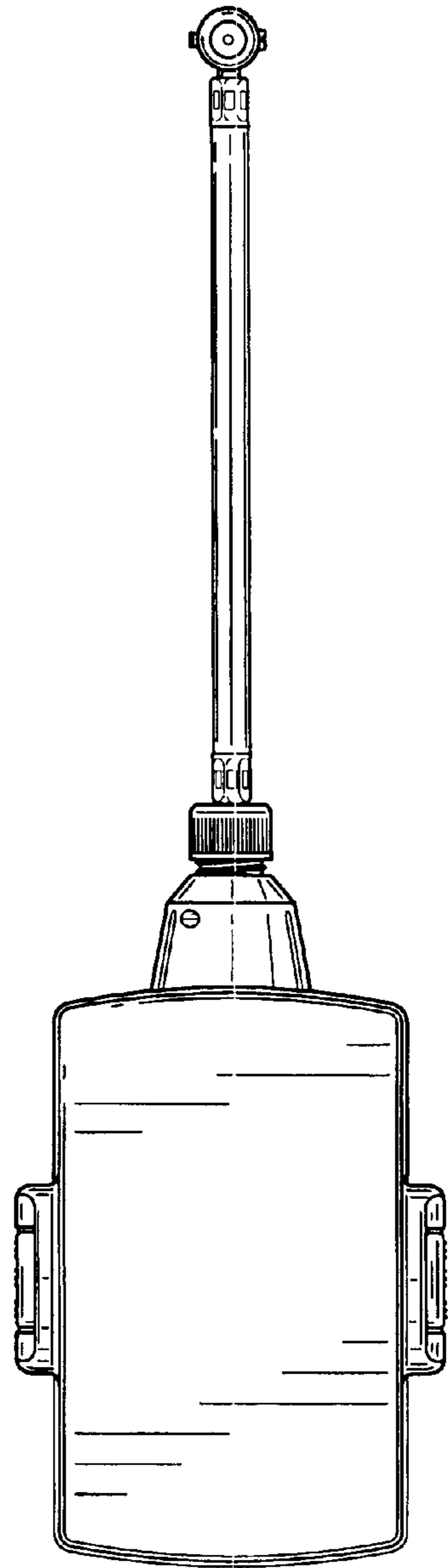

FIG. 7