



US00D464916S

(12) **United States Design Patent**
Golenz et al.

(10) **Patent No.:** **US D464,916 S**

(45) **Date of Patent:** **** Oct. 29, 2002**

(54) **CARGO TRAILER BODY**

D422,243 S * 4/2000 Keirstead D12/102

6,199,909 B1 3/2001 Kass et al.

D443,561 S * 6/2001 Voogt D12/102

(75) Inventors: **Douglas John Golenz**, Louisville, CO
(US); **Vaughn Goodbrand**, Superior,
CO (US)

* cited by examiner

(73) Assignee: **Goodbrand Enterprises LLC**,
Superior, CO (US)

Primary Examiner—Melody N. Brown

(74) *Attorney, Agent, or Firm*—F. A. Sirr; E. C. Hancock;
Holland & Hart LLP

(**) Term: **14 Years**

(57) **CLAIM**

(21) Appl. No.: **29/143,543**

The ornamental design for a cargo trailer body, as shown and
described.

(22) Filed: **Jun. 15, 2001**

(51) **LOC (7) Cl.** **12-10**

(52) **U.S. Cl.** **D12/102**

(58) **Field of Search** D12/102, 101;
286/418.6, 475, 656, 763.1; 296/173

DESCRIPTION

(56) **References Cited**

U.S. PATENT DOCUMENTS

- D272,525 S 2/1984 Paulina
- D373,748 S 9/1996 Fuller et al.
- D389,439 S * 1/1998 Friedrich D12/102
- D391,526 S * 3/1998 Kass et al. D12/102
- D396,668 S 8/1998 Ewald
- D405,727 S 2/1999 Ewald
- 6,042,175 A 3/2000 Williams

FIG. 1 is a front view of first embodiment of a cargo trailer
body showing our design.

FIG. 2 is a rear view of the first embodiment.

FIG. 3 is a left-side view of the first embodiment, with the
right-side view being a mirror image of FIG. 3.

FIG. 4 is a top view of the first embodiment.

FIG. 5 is a bottom view of the first embodiment; and,

FIG. 6 is a left side and top perspective view of the first
embodiment.

The broken lines are shown for illustrative purposes only
and form no part of the claimed design.

1 Claim, 5 Drawing Sheets

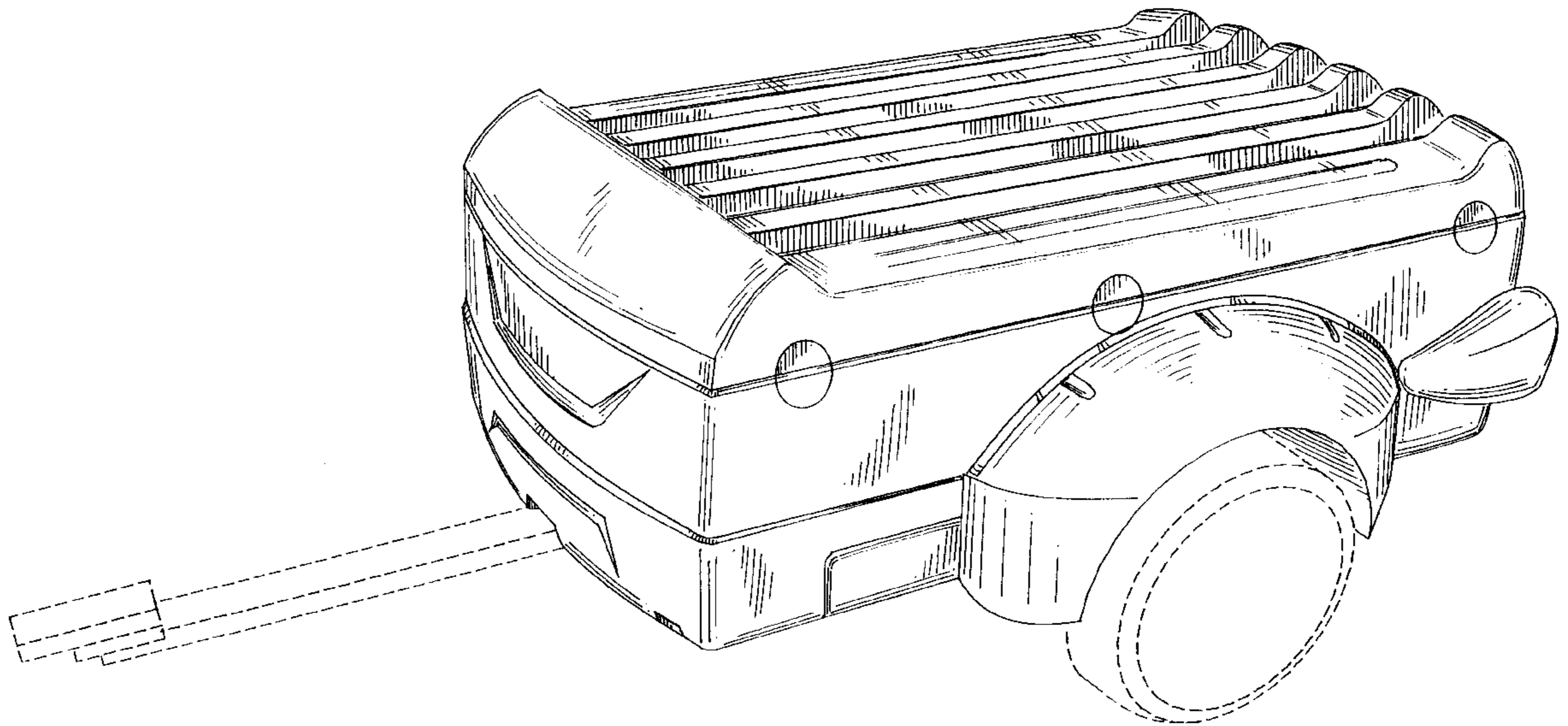

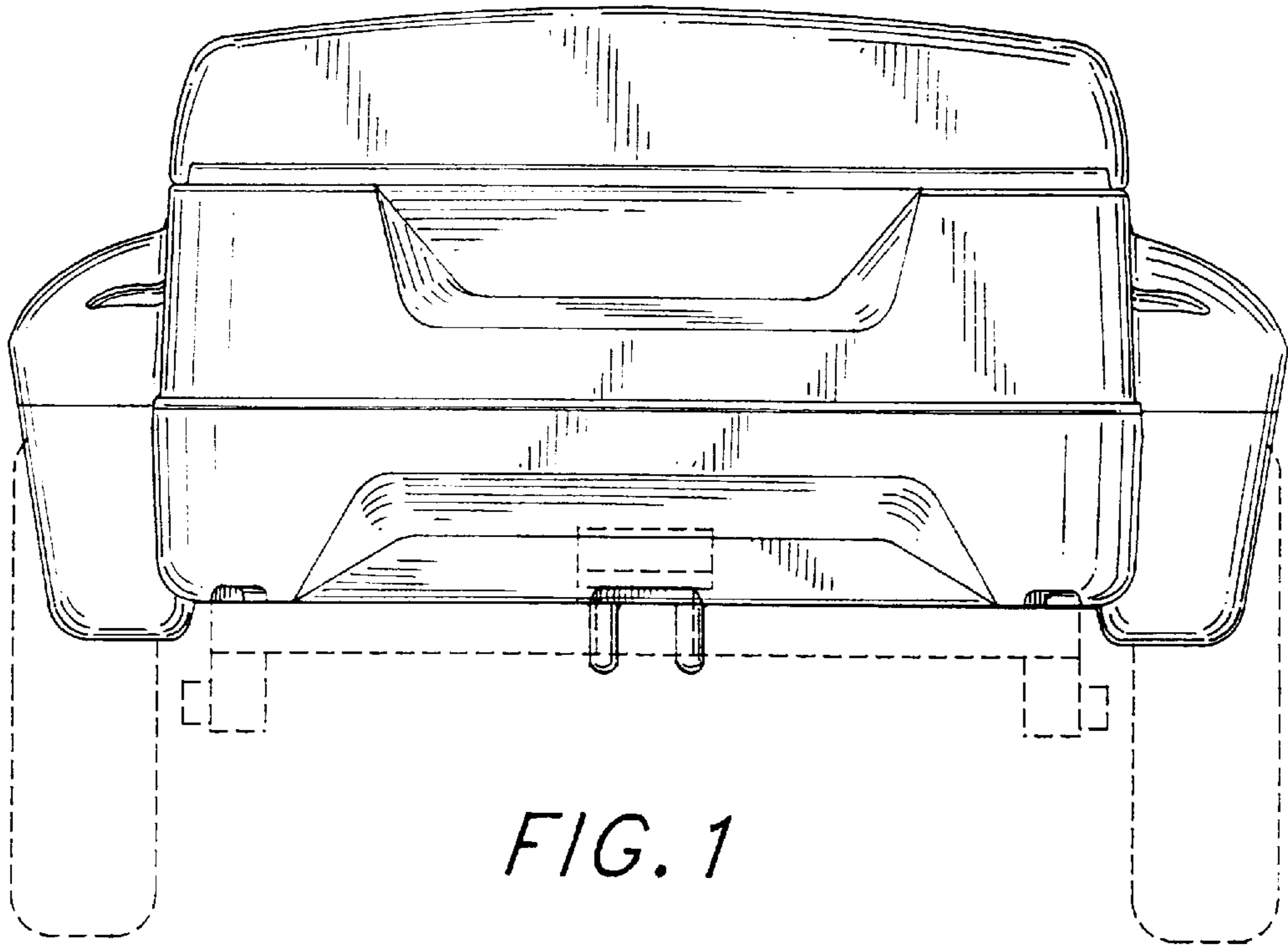

FIG. 1

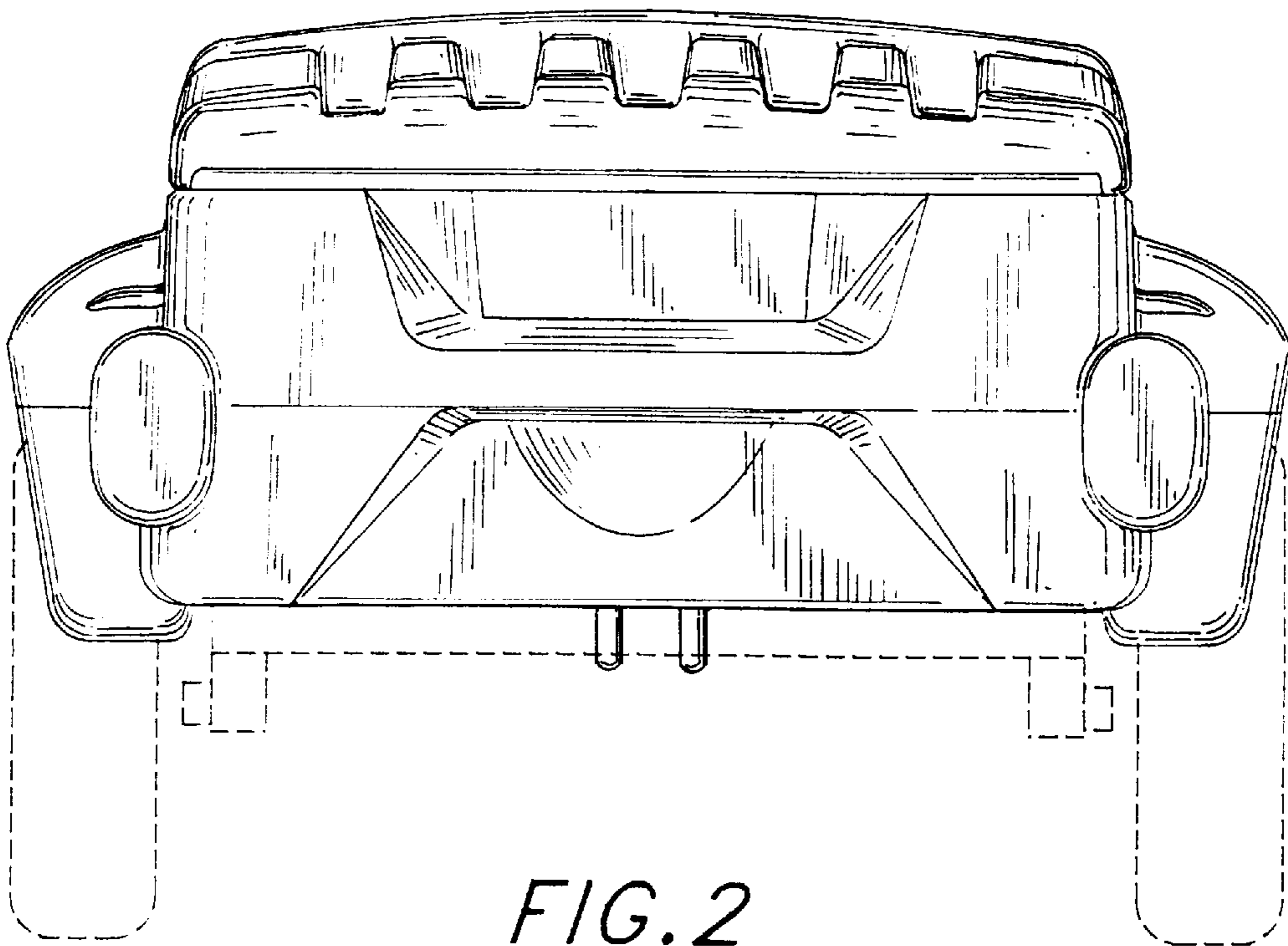

FIG. 2

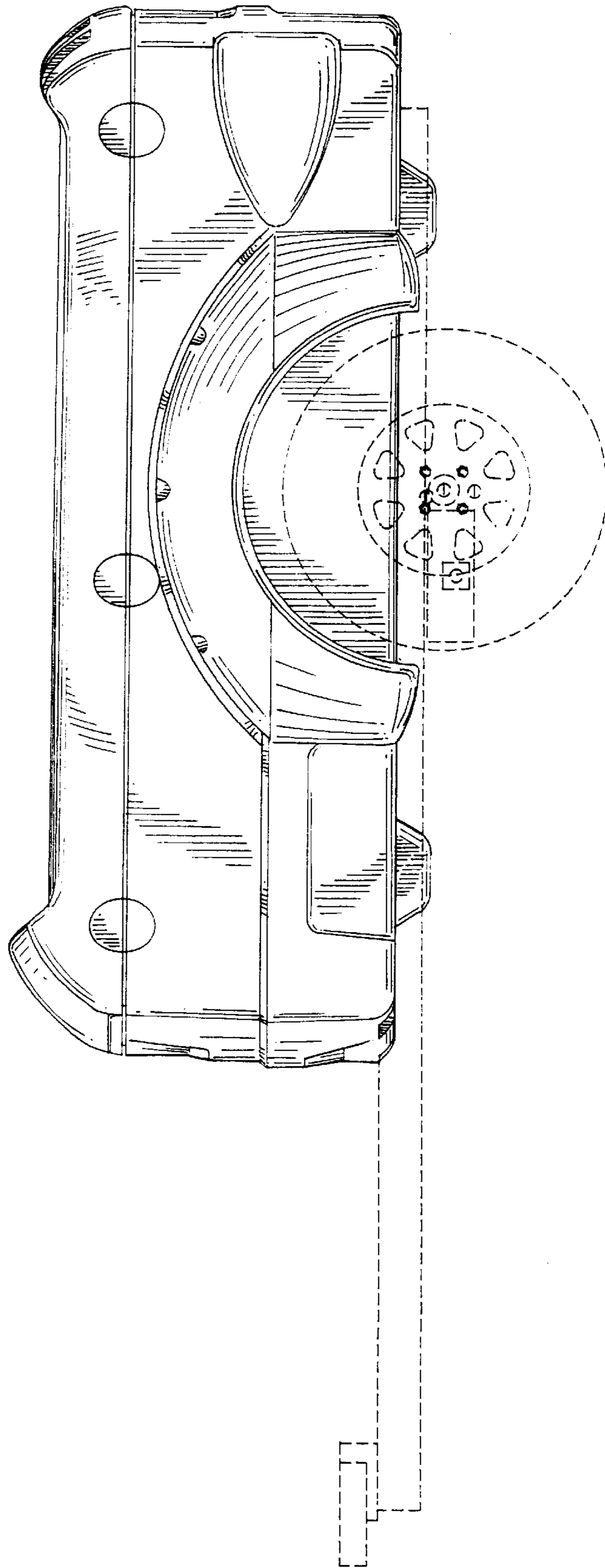

FIG. 3

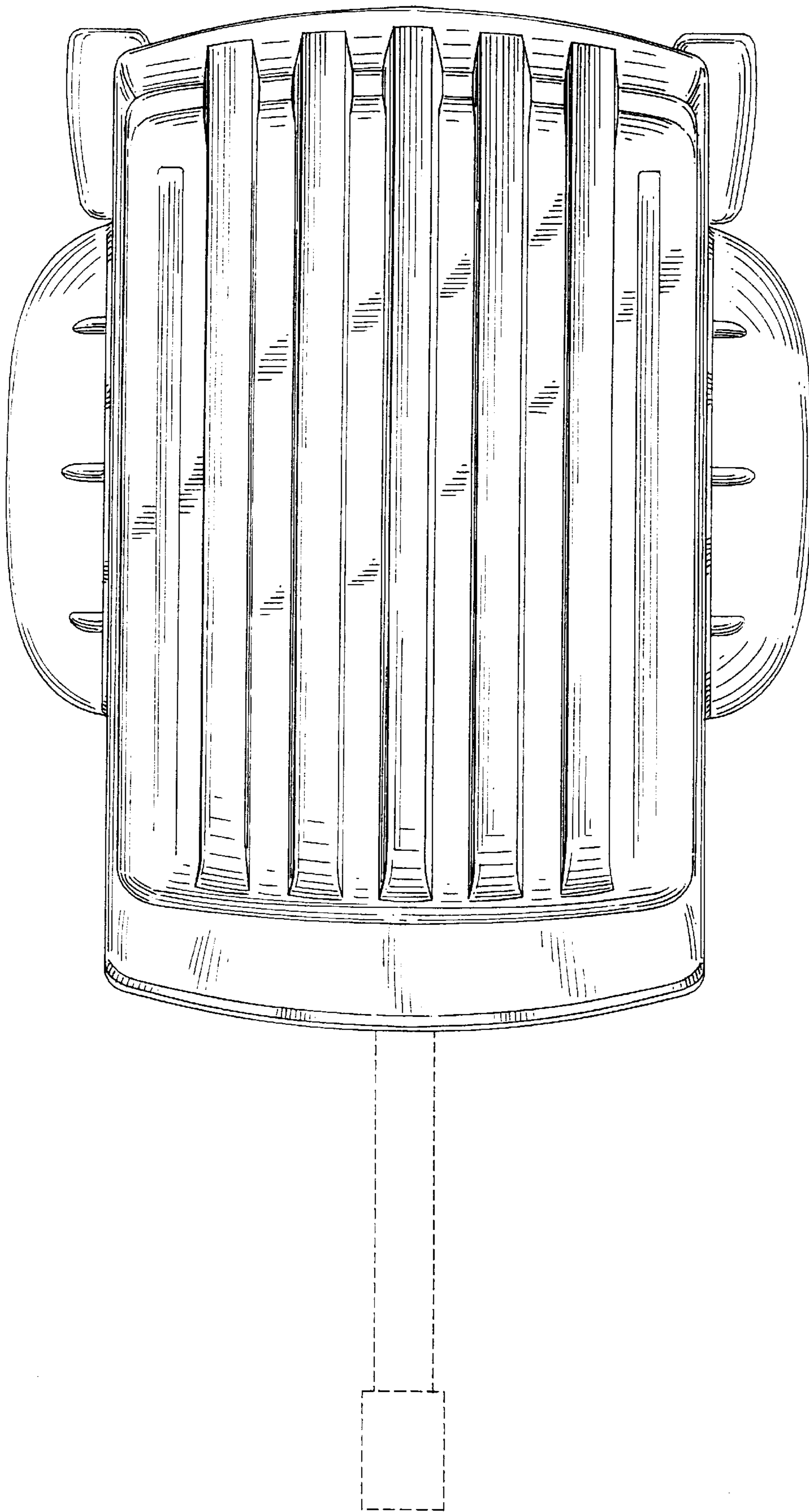

FIG. 4

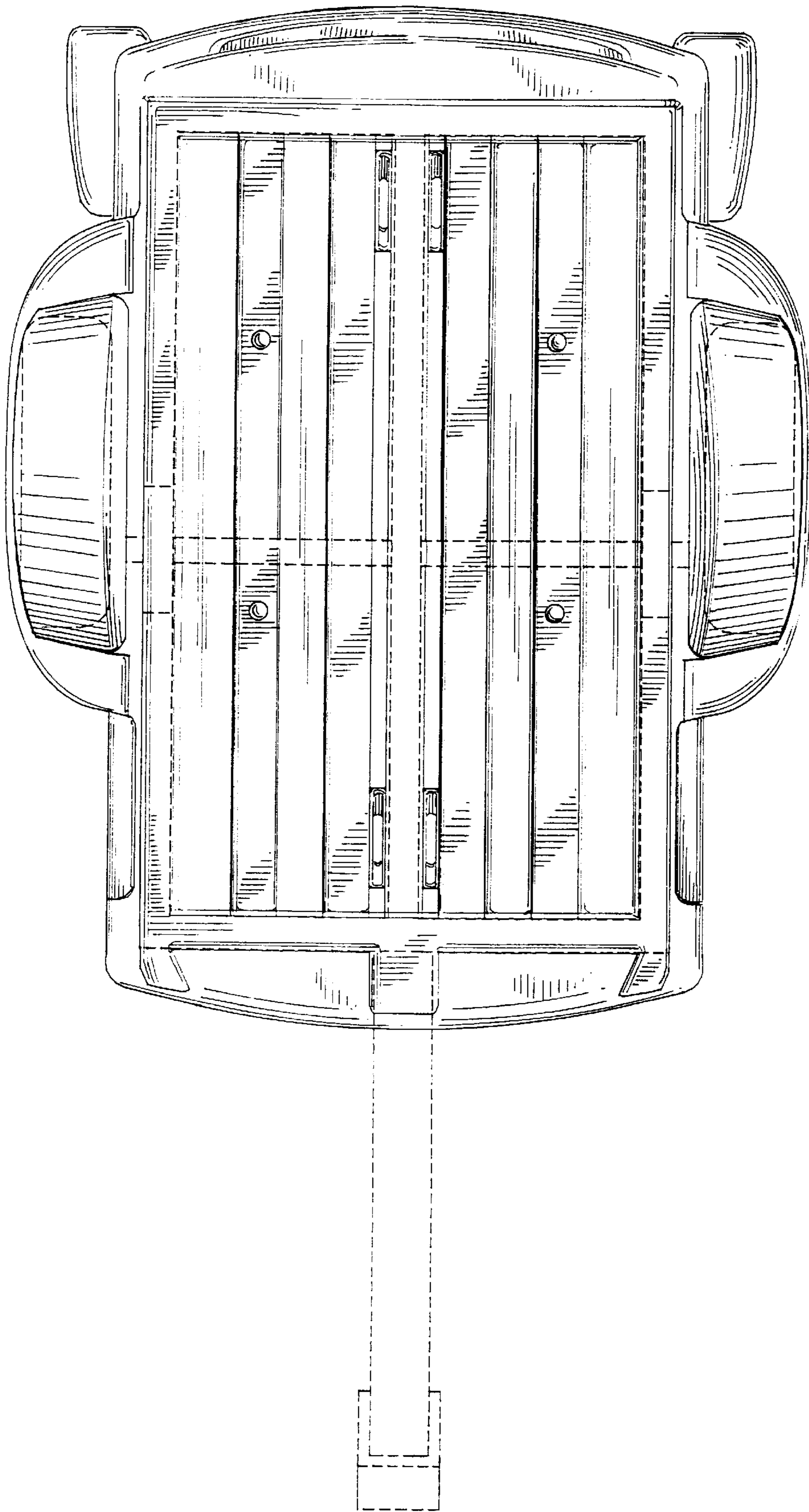

FIG. 5

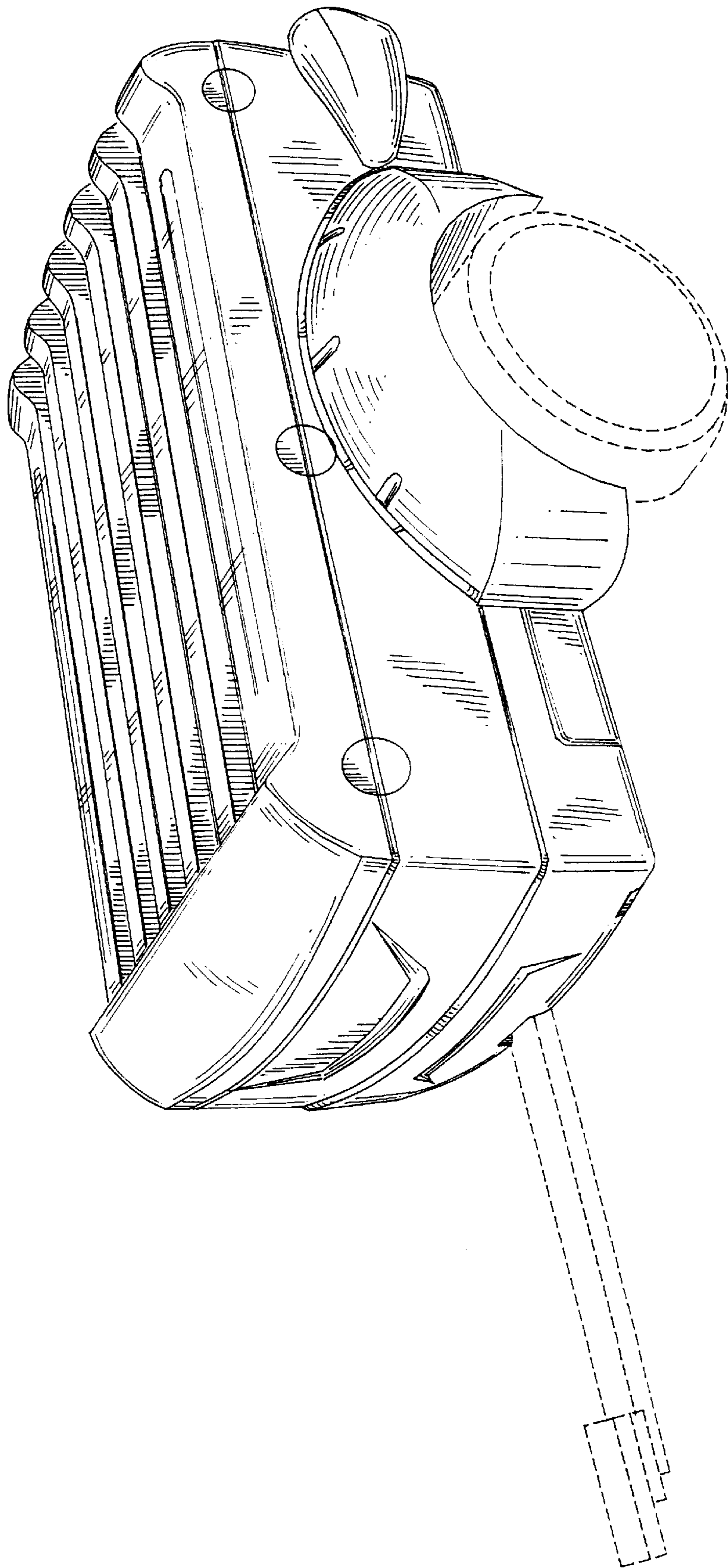

FIG. 6