



US00D464744S

(12) **United States Design Patent**
Kato et al.

(10) **Patent No.:** **US D464,744 S**

(45) **Date of Patent:** **** Oct. 22, 2002**

(54) **ARRAY OF LIGHT EMITTING DEVICES**

(75) Inventors: **Masaru Kato**, Tokushima (JP);
Kazunori Watanabe, Tokushima (JP)

(73) Assignee: **Nichia Corporation**, Anan (JP)

(**) Term: **14 Years**

(21) Appl. No.: **29/144,280**

(22) Filed: **Jul. 2, 2001**

(30) **Foreign Application Priority Data**

Feb. 16, 2001 (JP) 2001-003592

(51) **LOC (7) Cl.** **26-06**

(52) **U.S. Cl.** **D26/1**

(58) **Field of Search** D26/1, 2, 37-50;
D20/12; 362/157, 158, 171, 172, 173, 183-208;
D10/114

(56) **References Cited**

U.S. PATENT DOCUMENTS

D317,657 S * 6/1991 Iwata et al. D26/1
D440,513 S * 4/2001 Smith D10/114
D445,922 S * 7/2001 Yasuoka D26/1

* cited by examiner

Primary Examiner—Marcus A. Jackson

(74) *Attorney, Agent, or Firm*—Burns, Doane, Swecker & Mathis, LLP

(57) **CLAIM**

The ornamental design for a array of light emitting devices, as shown and described.

DESCRIPTION

FIG. 1 is a front elevational view of the first embodiment of a array of light emitting devices showing our new design; FIG. 2 is a rear elevational view thereof; FIG. 3 is a top plan view thereof; FIG. 4 is a bottom plan view thereof; FIG. 5 is a right side elevational view thereof; FIG. 6 is a left side elevational view thereof; FIG. 7 is a perspective view thereof; FIG. 8 is a front elevational view of the second embodiment of a array of light emitting devices showing our new design; FIG. 9 is a rear elevational view thereof; FIG. 10 is a top plan view thereof; FIG. 11 is a bottom plan view thereof; FIG. 12 is a right side elevational view thereof; FIG. 13 is a left side elevational view thereof; and, FIG. 14 is a perspective view thereof.

1 Claim, 8 Drawing Sheets

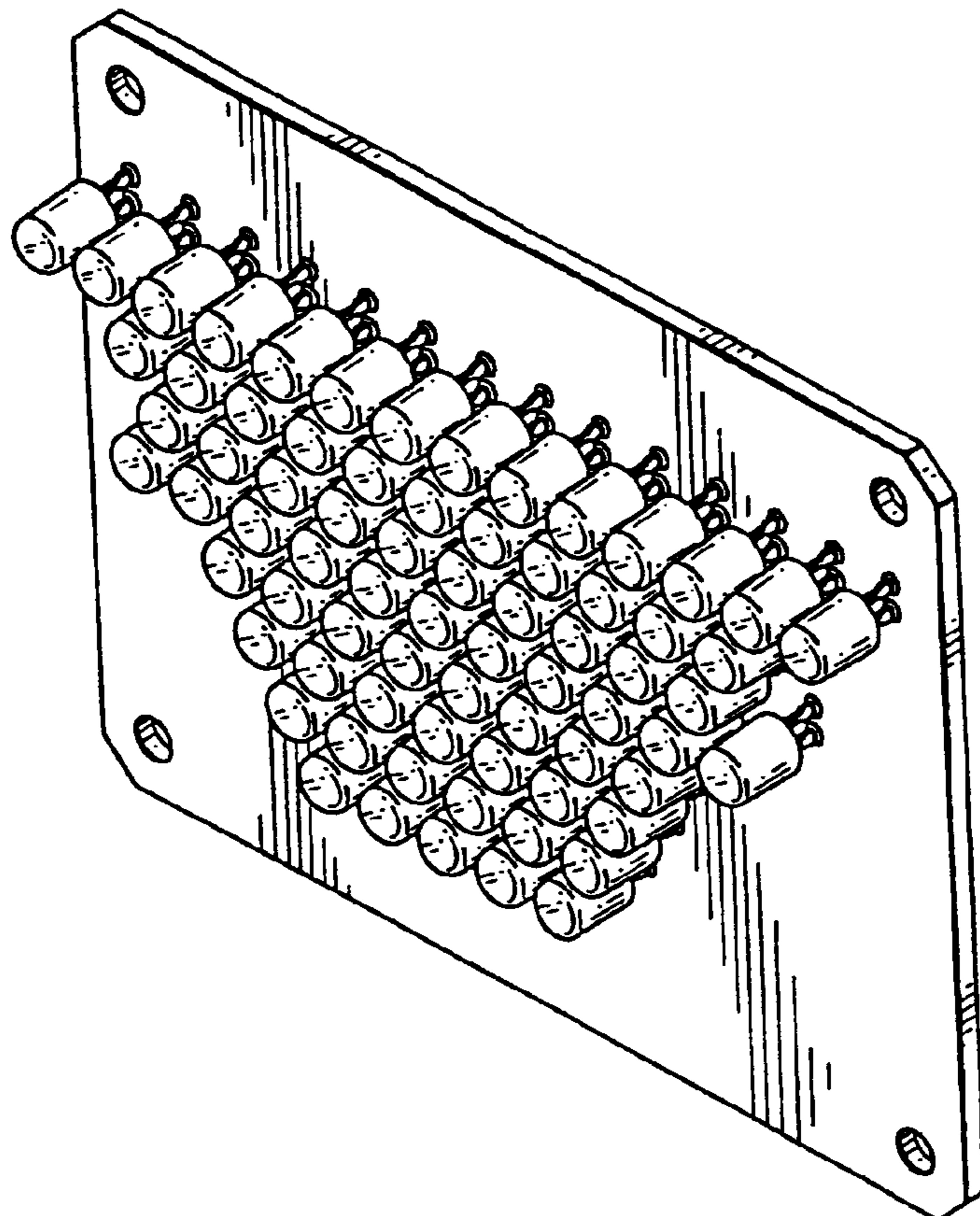

Fig. 1

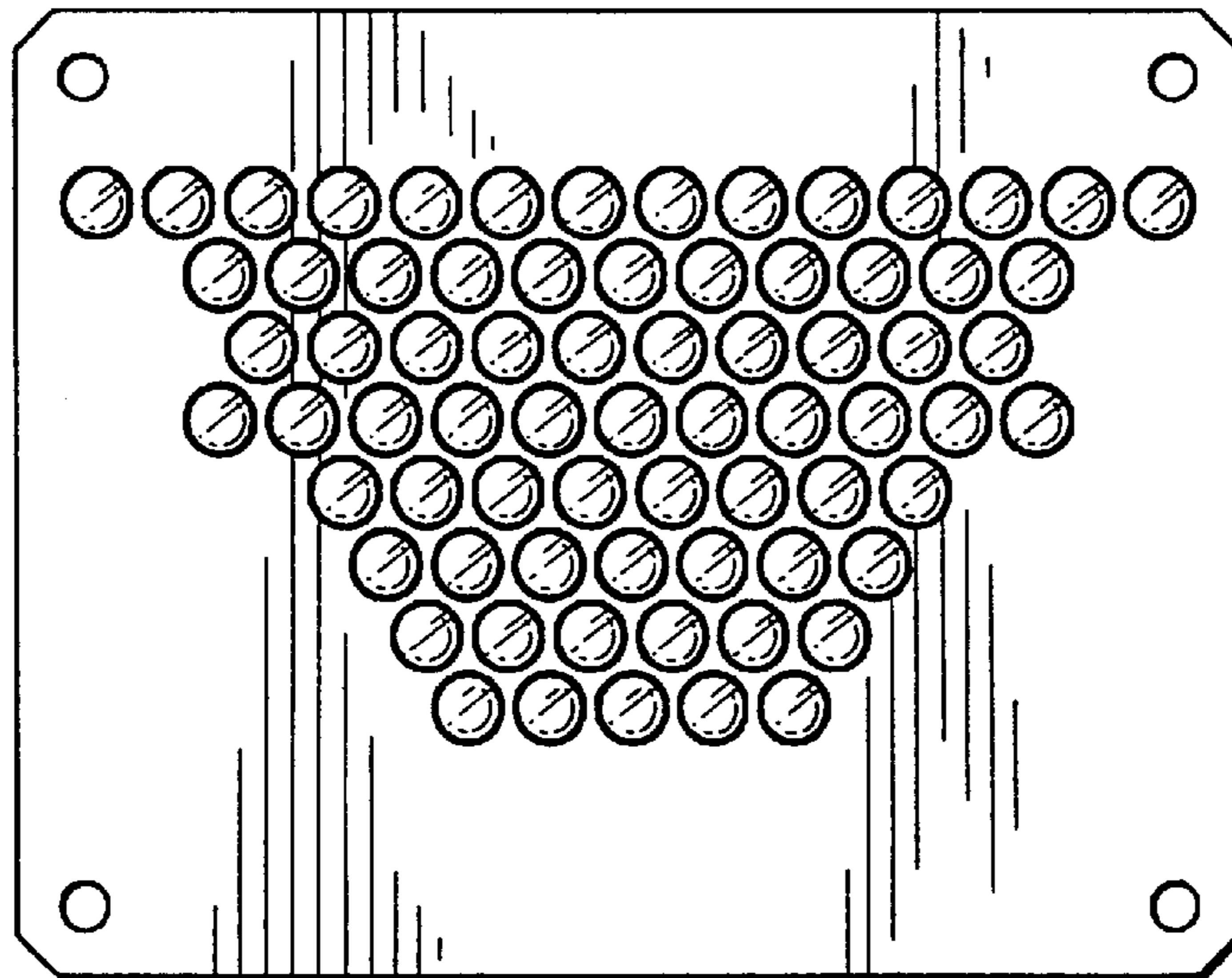

Fig. 2

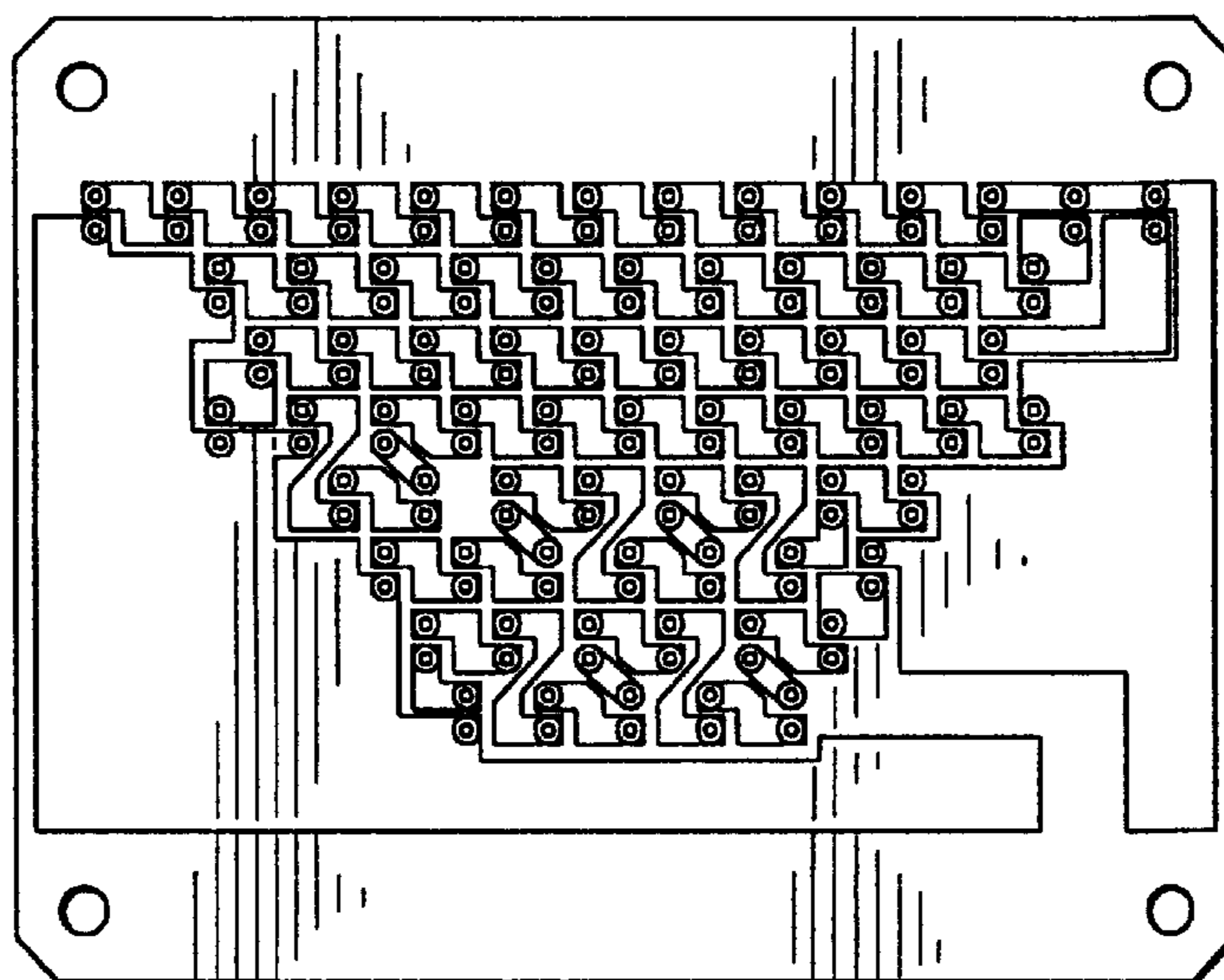

Fig. 3

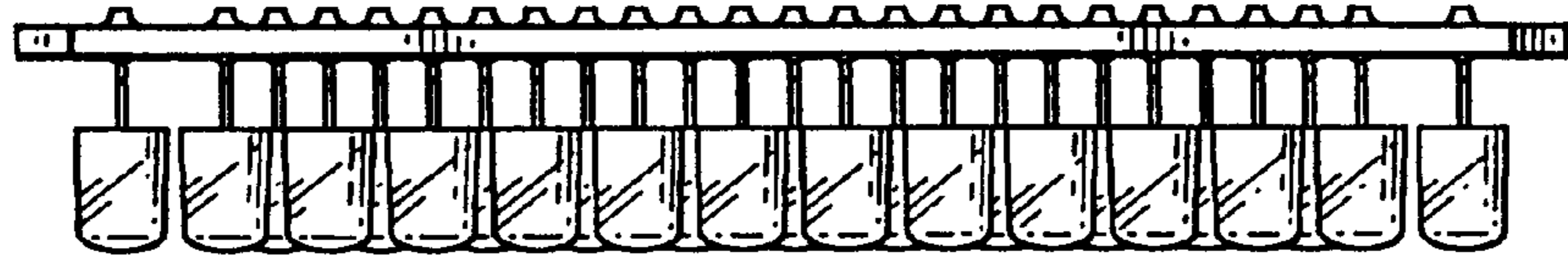

Fig. 4

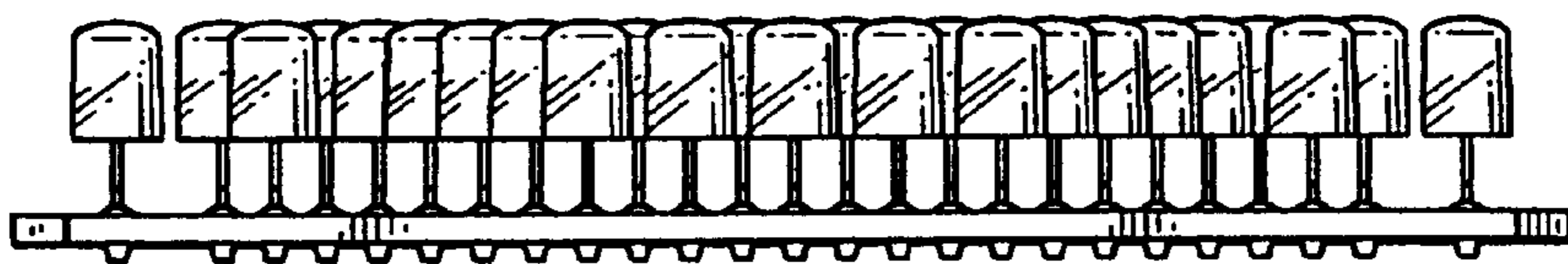

Fig. 5

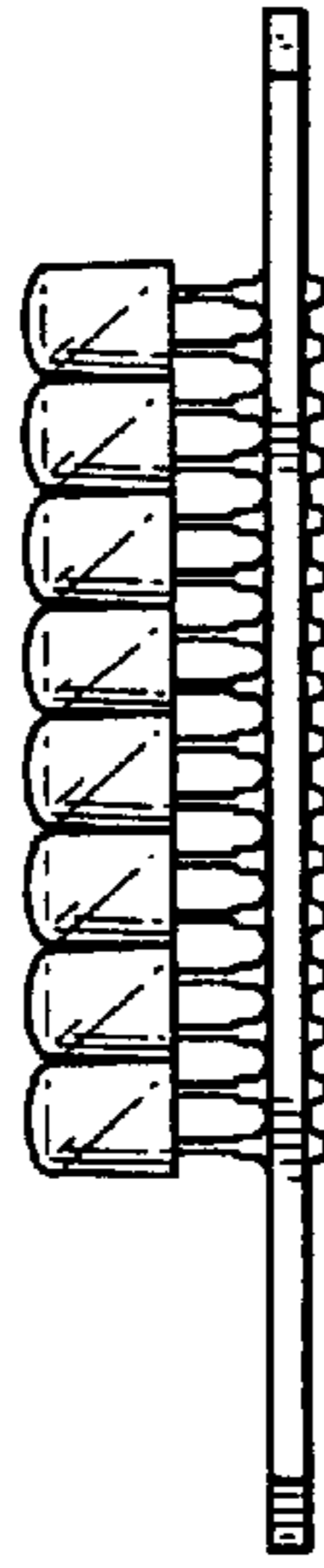

Fig. 6

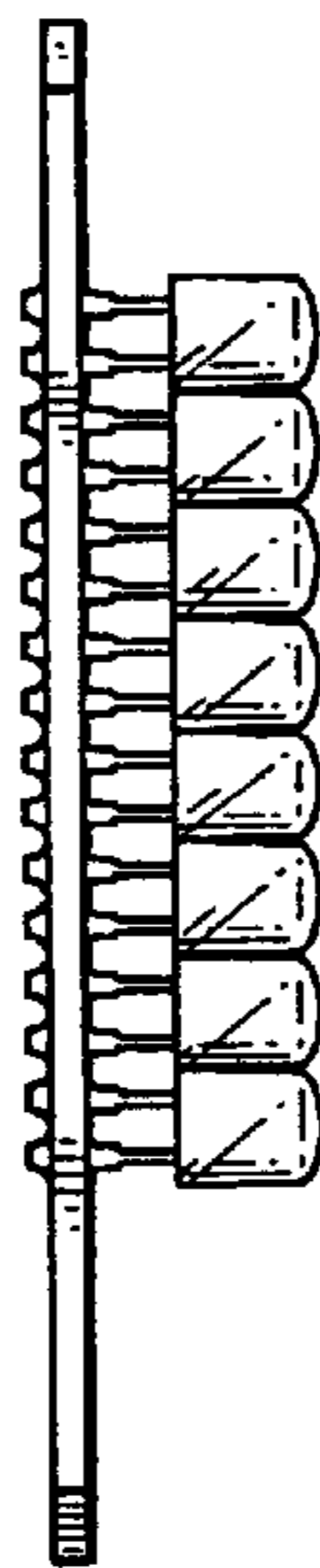

Fig. 7

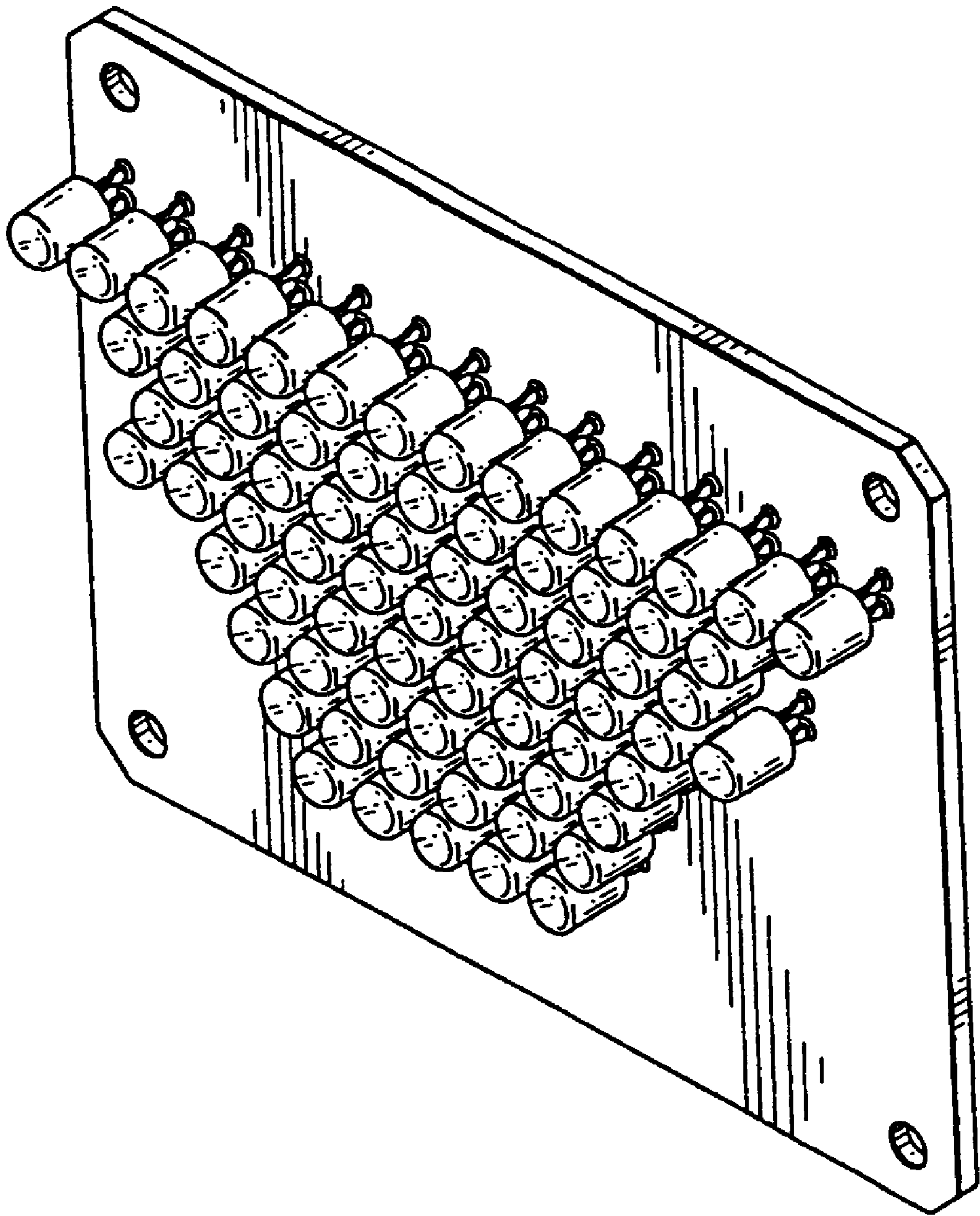

Fig. 8

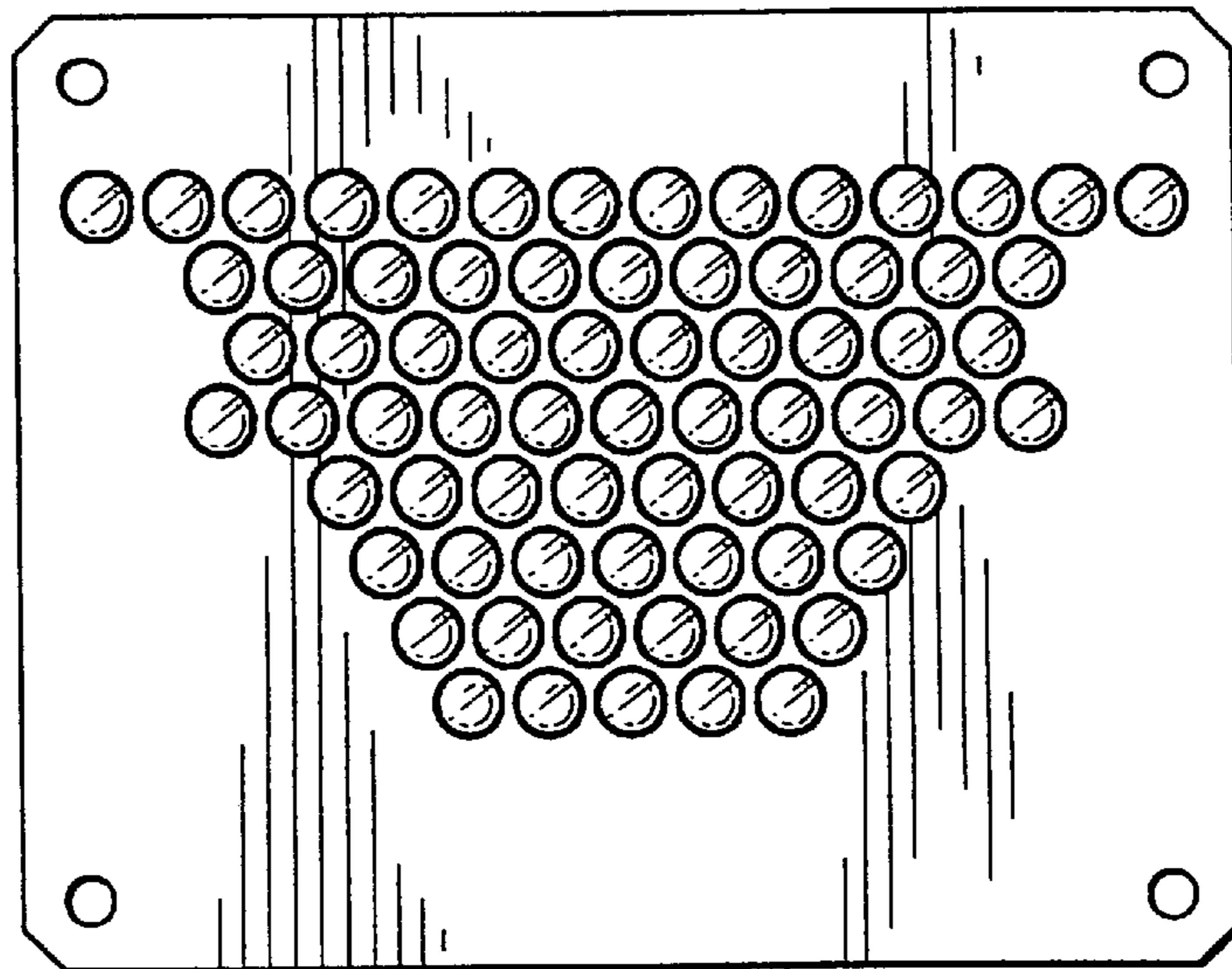

Fig. 9

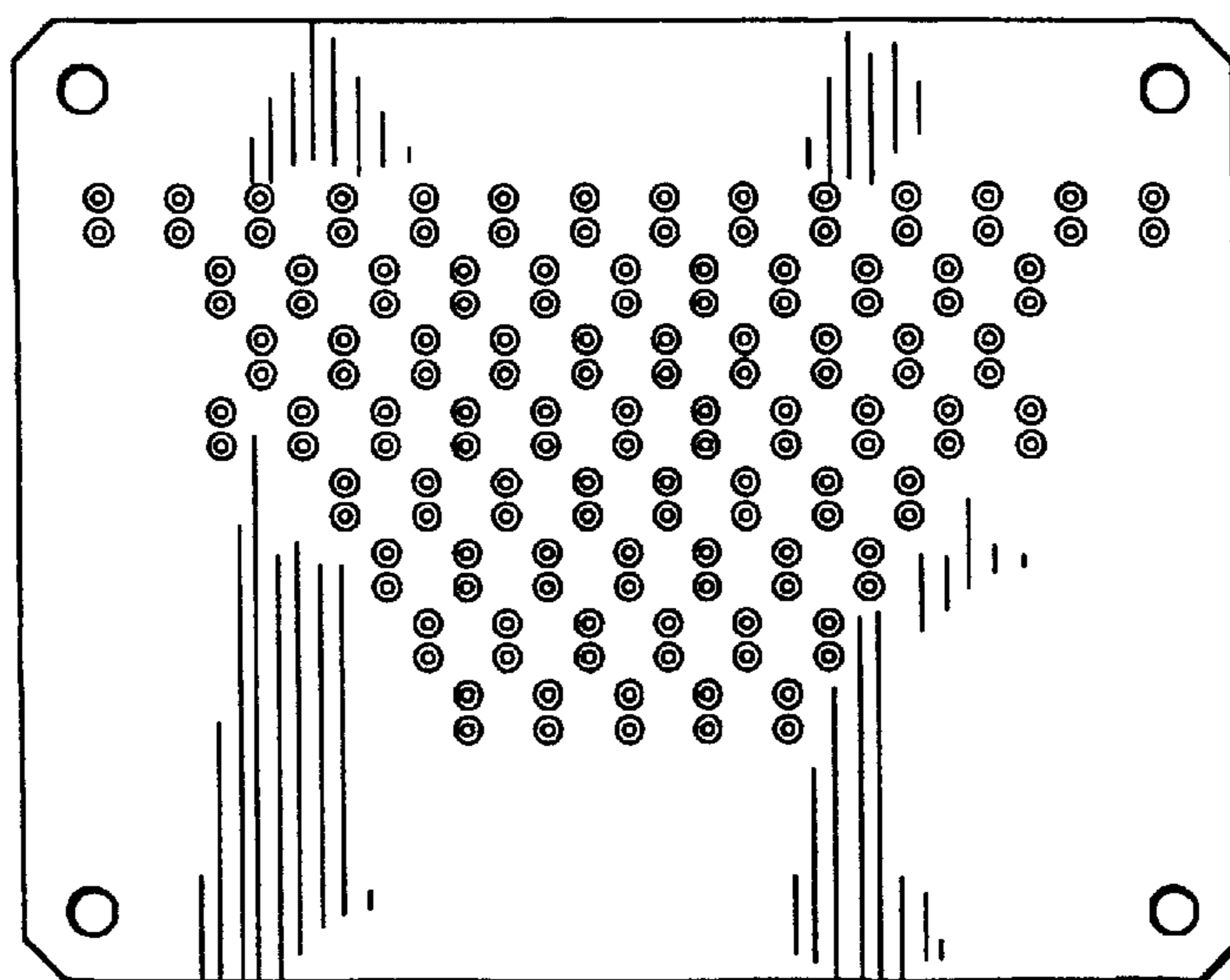

Fig. 10

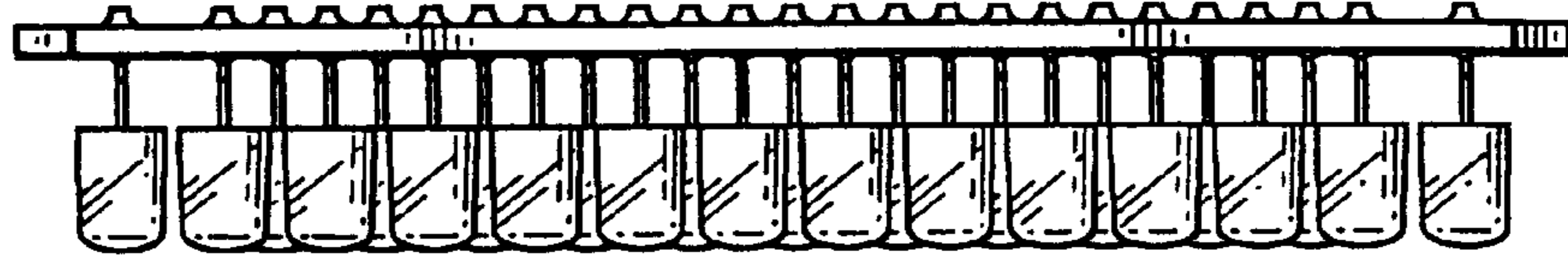

Fig. 11

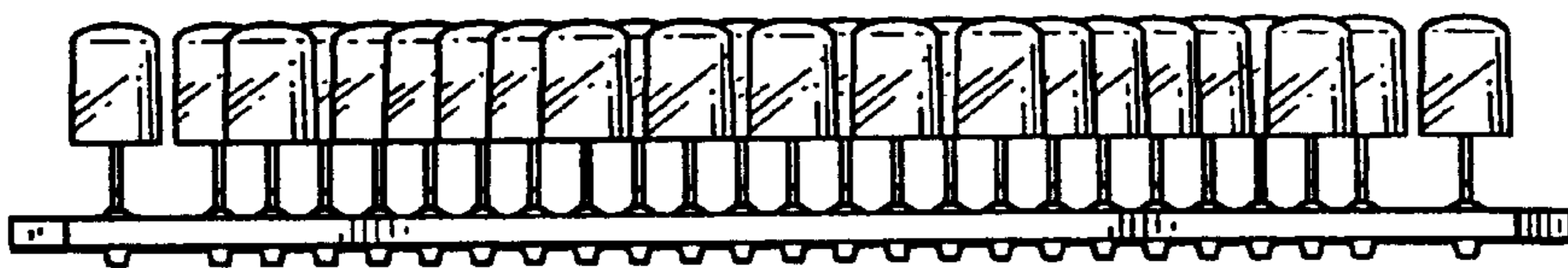

Fig. 12

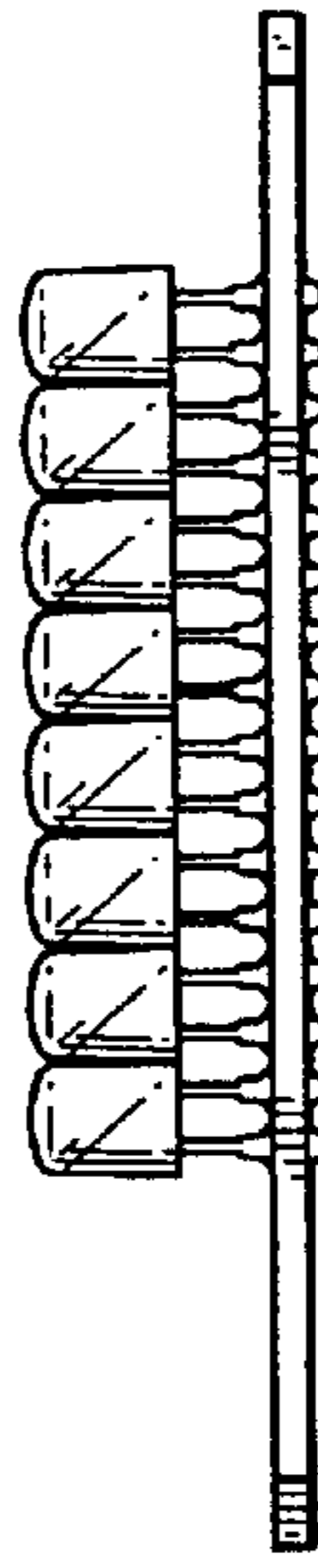

Fig. 13

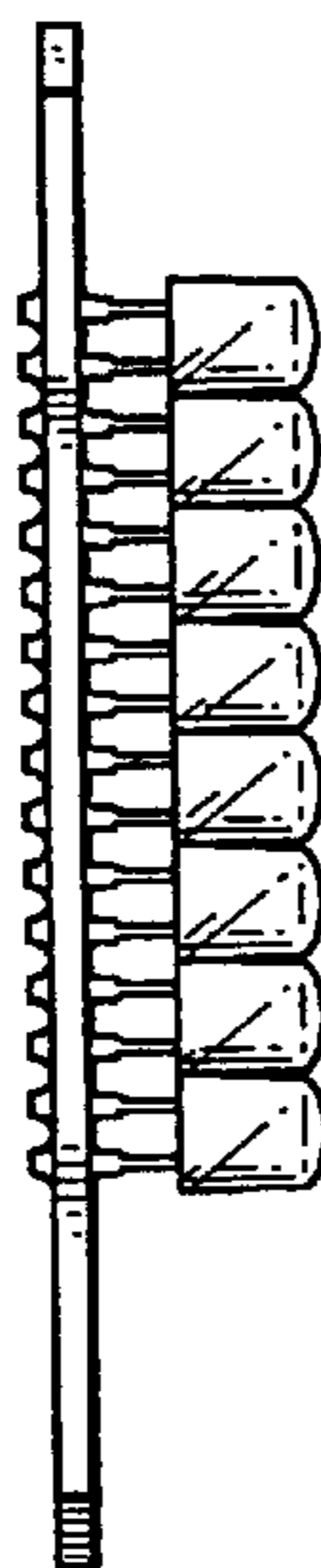

Fig. 14

