



US00D464597S

(12) **United States Design Patent**  
**Bassani**

(10) **Patent No.:** **US D464,597 S**

(45) **Date of Patent:** **\*\* Oct. 22, 2002**

(54) **AUTOMOBILE AND TRUCK GASKET-LESS CONNECTOR**

(75) **Inventor:** **Darryl C. Bassani**, Yorba Linda, CA (US)

(73) **Assignee:** **Bassani Manufacturing**, Anaheim, CA (US)

(\*\*) **Term:** **14 Years**

(21) **Appl. No.:** **29/105,228**

(22) **Filed:** **May 20, 1999**

(51) **LOC (7) Cl.** ..... **12-16**

(52) **U.S. Cl.** ..... **D12/194**

(58) **Field of Search** ..... D12/400, 194;  
285/382.5, 222, 263, 111, 368; 29/523,  
890.044, 890.08; 138/37, 39, 44, 109, 103;  
181/225, 227-228, 202, 277, 347

(56) **References Cited**

**U.S. PATENT DOCUMENTS**

3,179,449 A	4/1965	Markisen
3,188,115 A	6/1965	Morrish et al.
3,752,509 A	8/1973	Stafford
4,209,177 A	6/1980	Hall
4,277,092 A	7/1981	Viers
4,640,537 A	2/1987	Chaix et al.
5,149,147 A	9/1992	Kastrup et al.
5,374,086 A	12/1994	Higgins
5,393,108 A	2/1995	Kerr

D374,647 S	* 10/1996	Capra	.....	D12/194
D381,308 S	* 7/1997	Manning	.....	D12/194
D386,137 S	* 11/1997	Bailey	.....	D12/194
5,713,611 A	2/1998	Kurimoto et al.		
5,884,666 A	* 3/1999	Johnson	.....	138/39

\* cited by examiner

*Primary Examiner*—Stacia Cadmus

(74) *Attorney, Agent, or Firm*—Knobbe, Martens, Olson & Bear, LLP

(57) **CLAIM**

The ornamental design for an automobile and truck gasket-less connector, as shown and described.

**DESCRIPTION**

FIG. 1 is a top plan view of an automobile and truck gasket-less connector, showing my new design prior to assembly;

FIG. 2 is an elevational view of the automobile and truck gasket-less connector taken along the lines 2—2 of FIG. 1;

FIG. 3 is an elevational view of the automobile and truck gasket-less connector taken along the lines 3—3 of FIG. 1;

FIG. 4 is a top plan view of the automobile and truck gasket-less connector of FIG. 1 showing my new design after assembly;

FIG. 5 is a left side elevational view of the automobile and truck gasket-less connector of FIG. 4; and,

FIG. 6 is a right side elevational view of the automobile and truck gasket-less connector of FIG. 4.

**1 Claim, 2 Drawing Sheets**

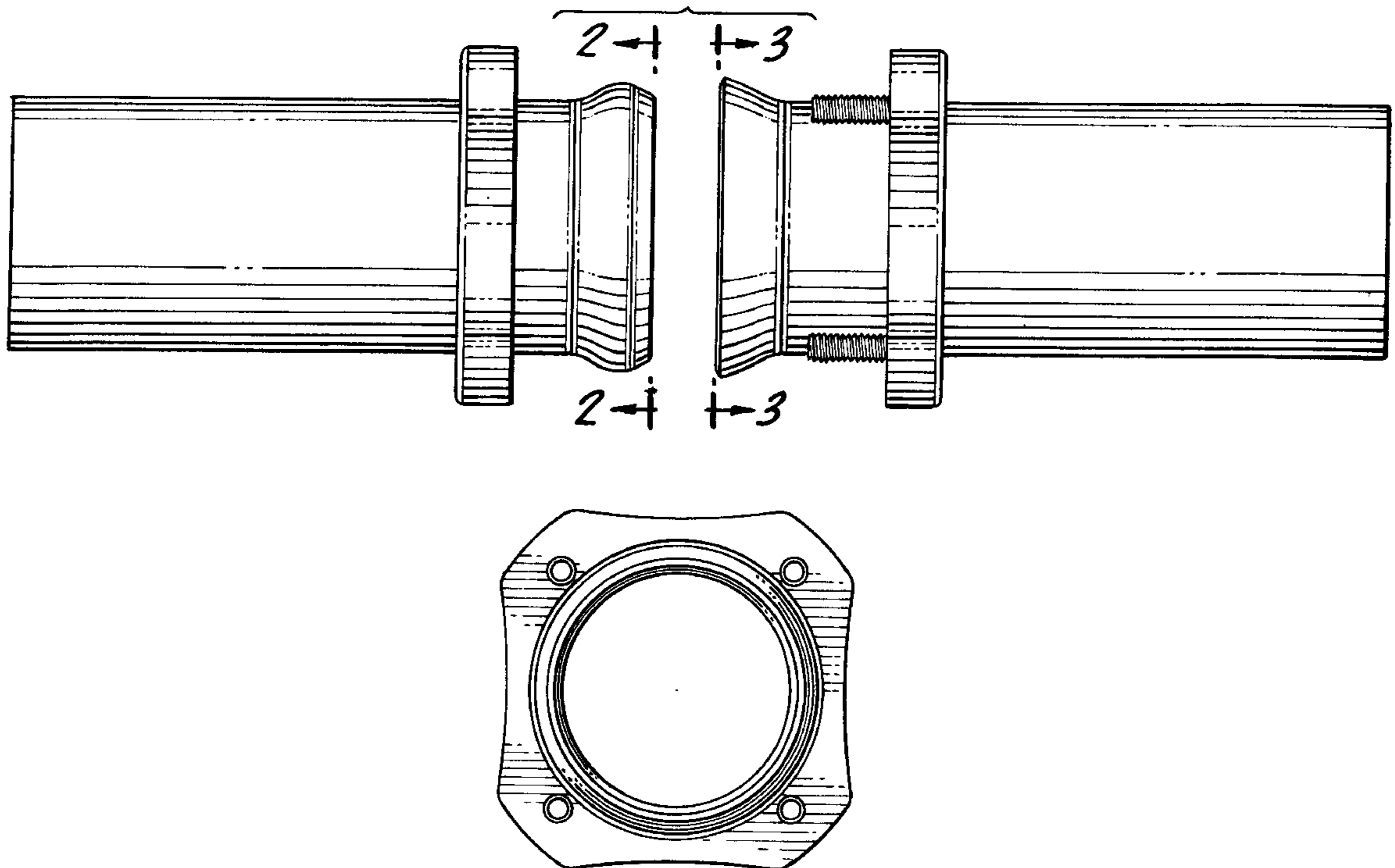

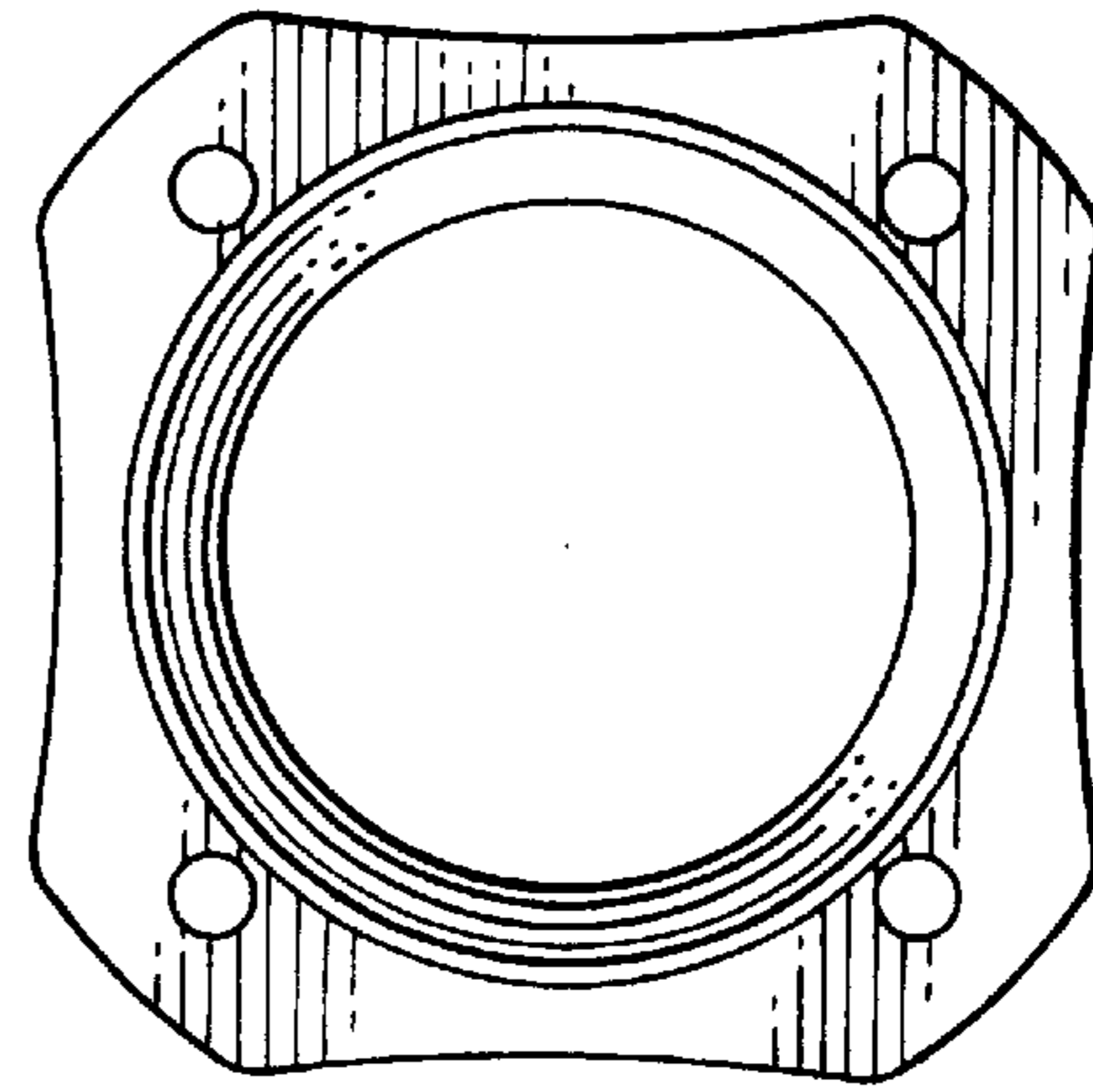
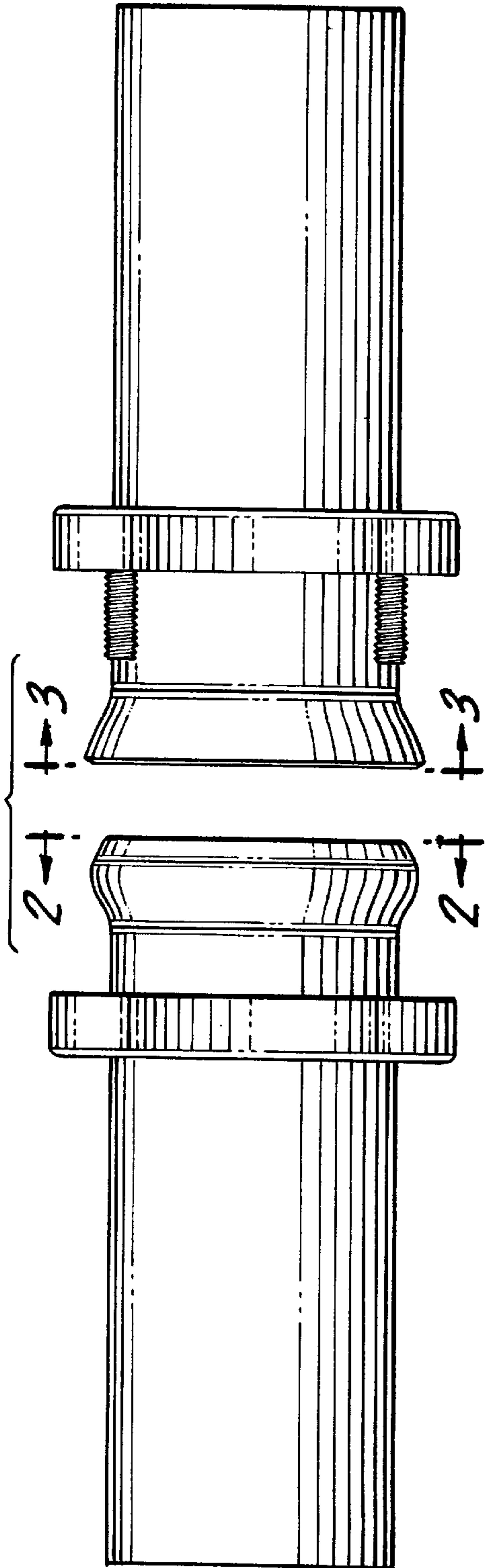

FIG. 3.

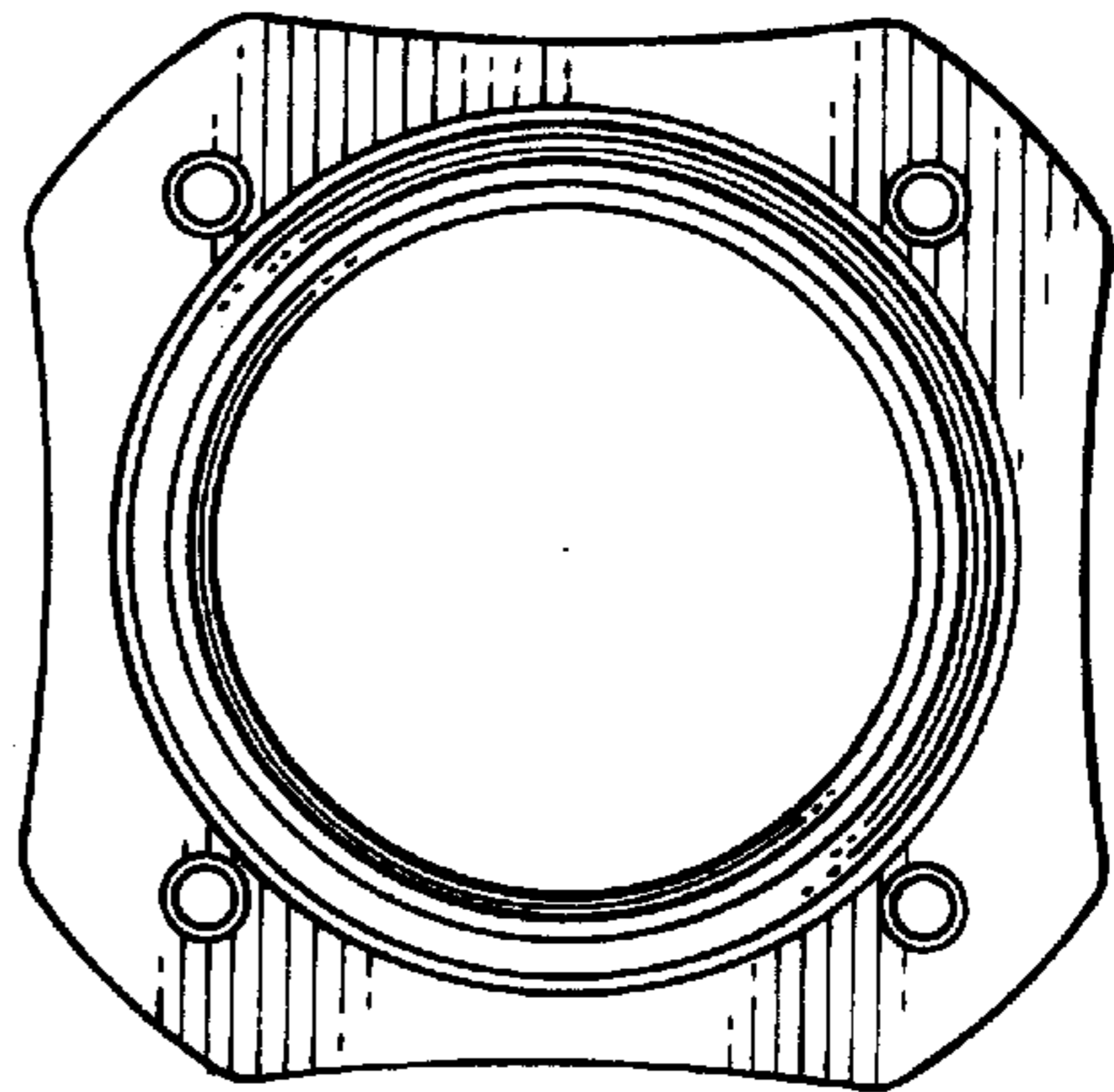

FIG. 2.

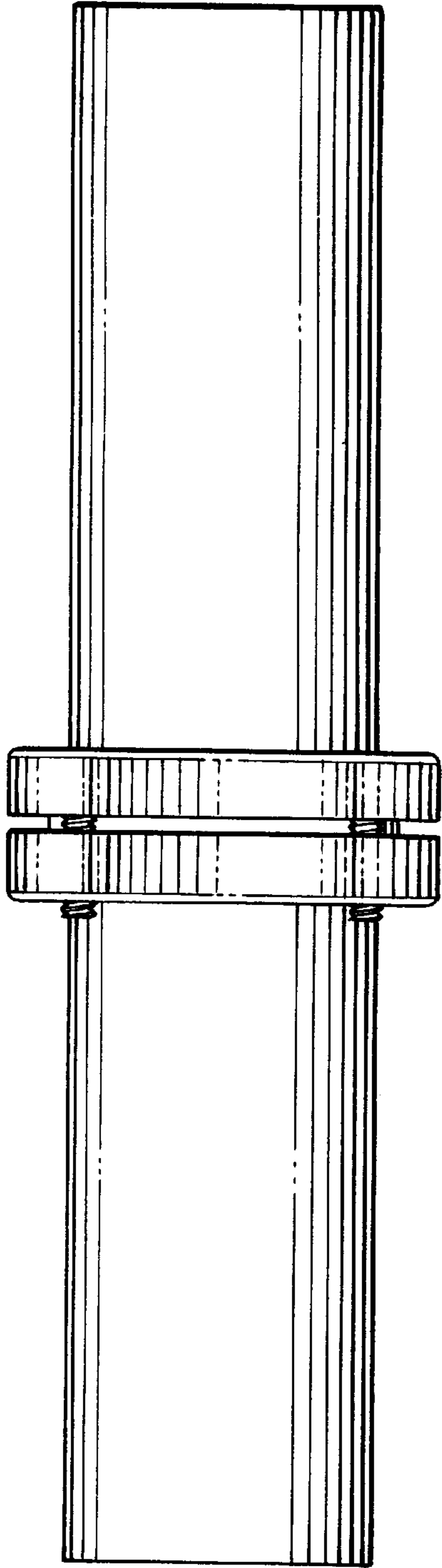

FIG. 4.

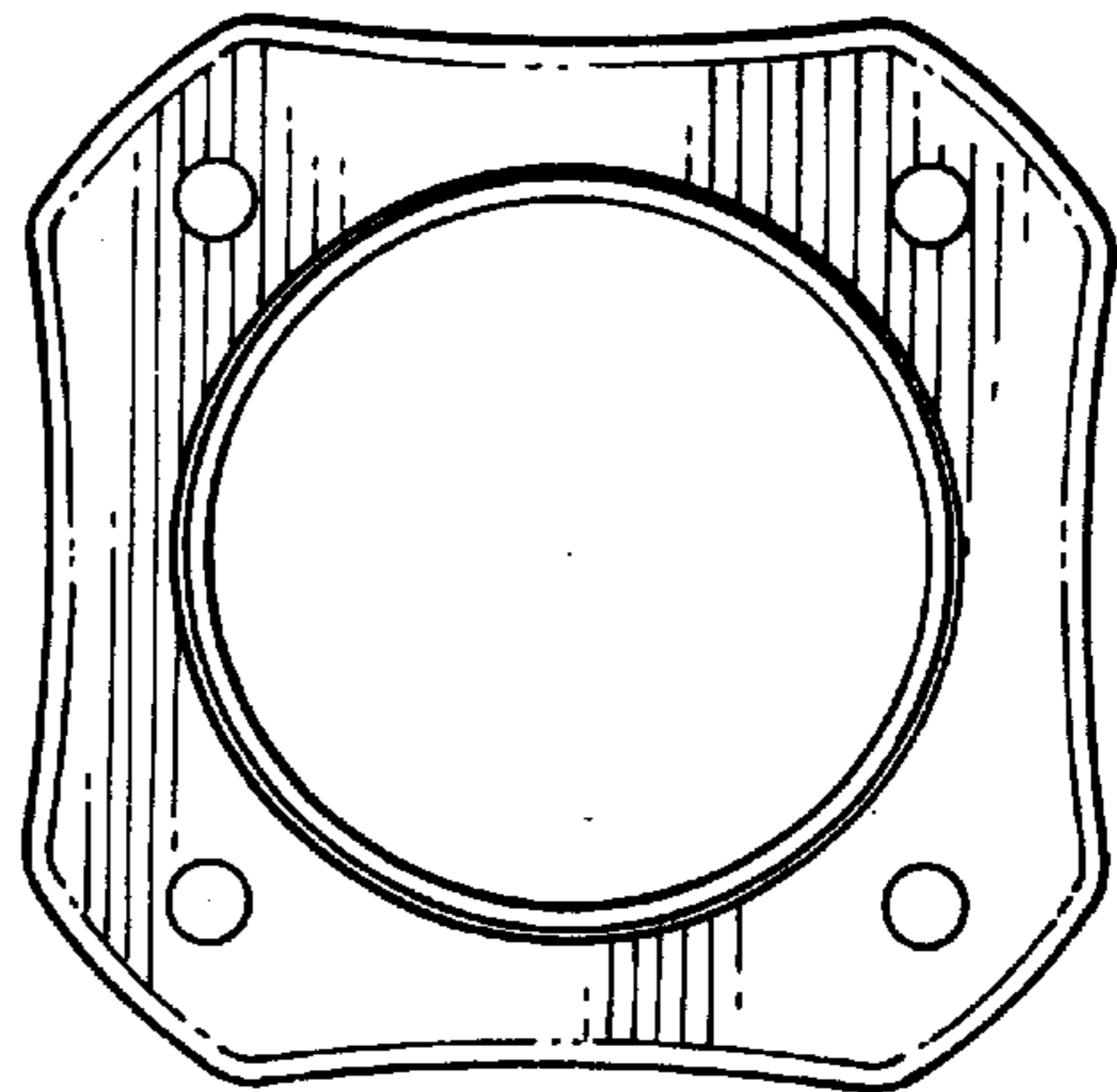

FIG. 5.

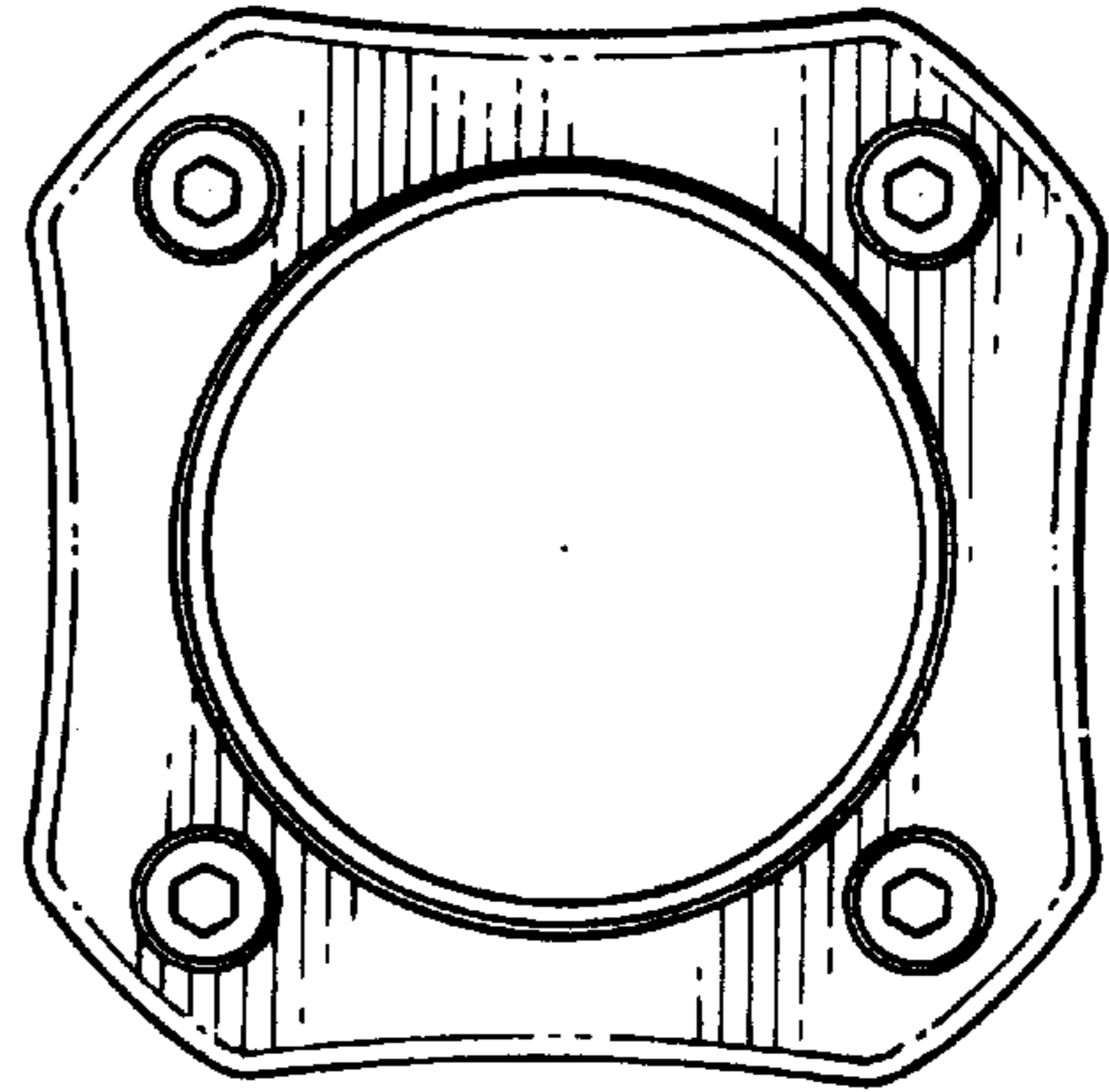

FIG. 6.

UNITED STATES PATENT AND TRADEMARK OFFICE  
**CERTIFICATE OF CORRECTION**

PATENT NO. : Des. 464,597 S  
DATED : October 22, 2002  
INVENTOR(S) : Darryl C. Bassani

Page 1 of 1

It is certified that error appears in the above-identified patent and that said Letters Patent is hereby corrected as shown below:

Title page,

Item [54], the title which reads, "**AUTOMOBILE AND TRUCK GASKET-LESS CONNECTOR,**" should read -- **AUTOMOBILE AND TRUCK GASKET-LESS EXHAUST CONNECTOR.** --

Signed and Sealed this

Twenty-ninth Day of April, 2003

A handwritten signature in black ink, appearing to read "James E. Rogan", written over a horizontal line.

JAMES E. ROGAN  
*Director of the United States Patent and Trademark Office*