



US00D464324S

(12) **United States Design Patent**
Hwang

(10) **Patent No.:** **US D464,324 S**

(45) **Date of Patent:** **** Oct. 15, 2002**

(54) **SPACER USED BETWEEN GBIC GUIDE RAILS**

(75) **Inventor:** **Jenq-Yih Hwang, Irvine, CA (US)**

(73) **Assignee:** **Hon Hai Precision Ind. Co., Ltd., Taipei Hsien (TW)**

(**) **Term:** **14 Years**

(21) **Appl. No.:** **29/140,941**

(22) **Filed:** **Apr. 26, 2001**

(51) **LOC (7) Cl.** **13-03**

(52) **U.S. Cl.** **D13/154**

(58) **Field of Search** D9/414; D13/152, D13/154, 156, 184, 199; D14/434, 447, 457; 361/790; 439/108, 135, 567, 753

(56) **References Cited**

U.S. PATENT DOCUMENTS

- D31,836 S * 11/1899 Heib D13/154
- D207,534 S * 5/1967 Dobbs et al. D13/184
- D340,446 S * 10/1993 Dalesandro D13/119

- 6,201,709 B1 * 3/2001 Justiniano et al. 361/790
- D449,282 S * 10/2001 Kramer D13/199
- 6,304,436 B1 * 10/2001 Branch et al. 439/135
- 6,354,875 B1 * 3/2002 Wu 439/607

* cited by examiner

Primary Examiner—Robert M. Spear

(74) *Attorney, Agent, or Firm*—Wei Te Chung

(57) **CLAIM**

The ornamental design for a spacer used between GBIC guide rails, as shown and described.

DESCRIPTION

FIG. 1 is a perspective view of a spacer used between GBIC guide rails showing my new design;
 FIG. 2 is a right side elevational view thereof;
 FIG. 3 is a left side elevational view thereof;
 FIG. 4 is a front view thereof;
 FIG. 5 is a rear view thereof;
 FIG. 6 is a top plan view thereof; and,
 FIG. 7 is a bottom plan view thereof.

1 Claim, 5 Drawing Sheets

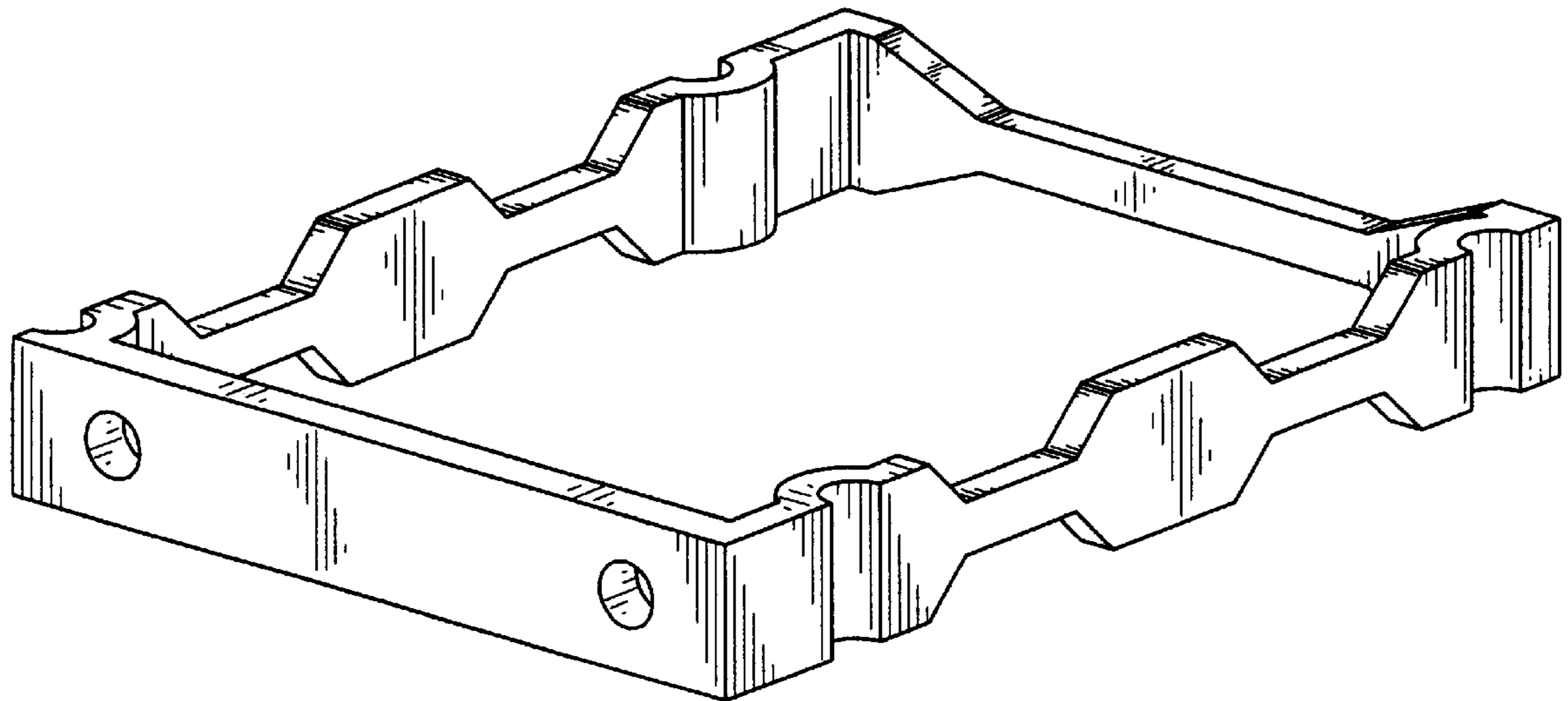

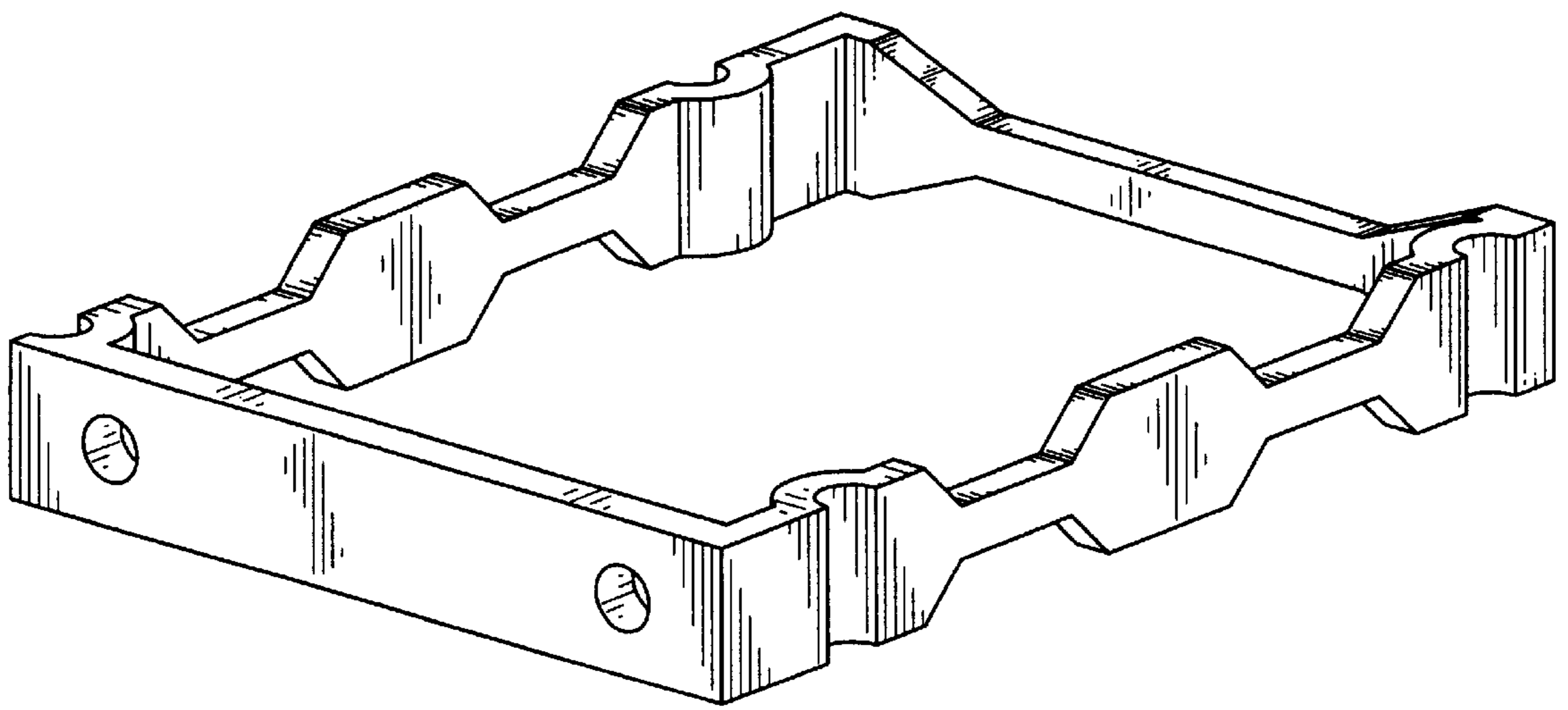

FIG. 1

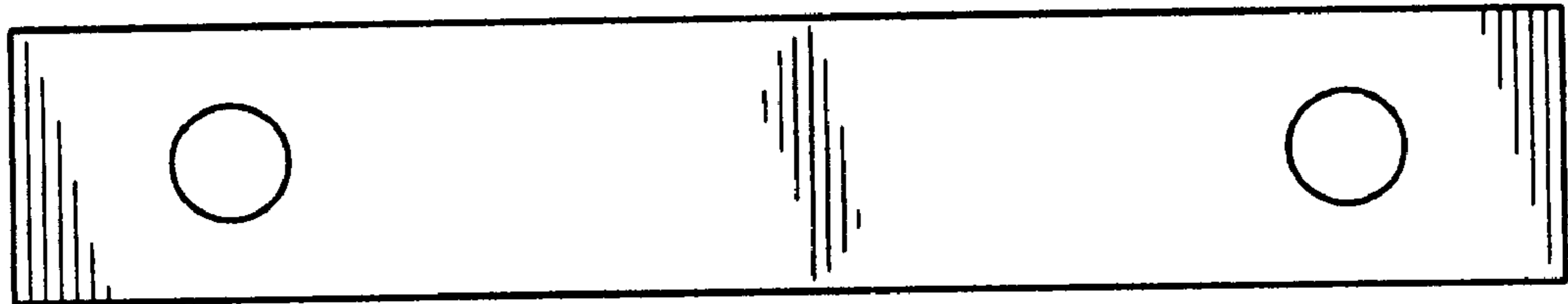

FIG. 2

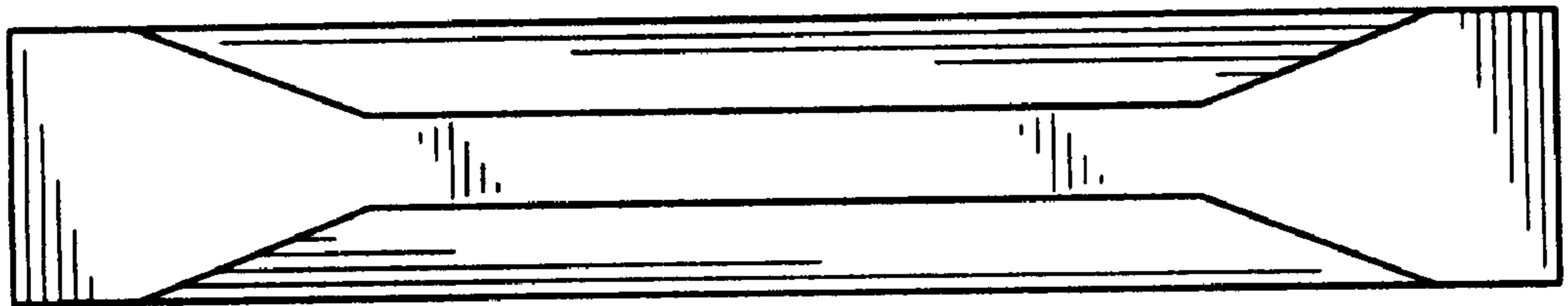

FIG. 3

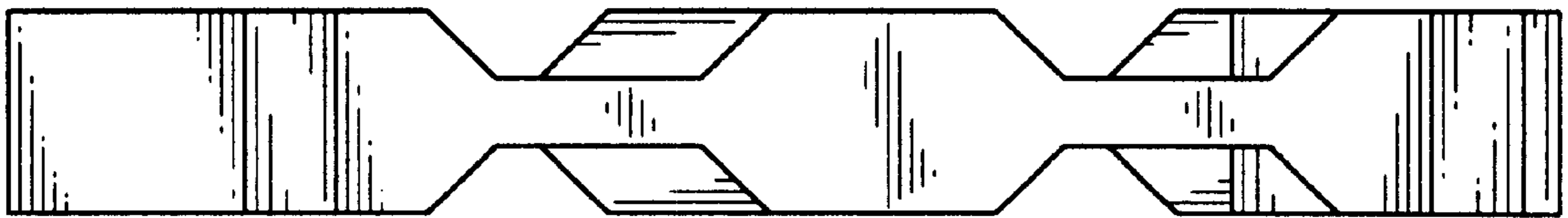

FIG. 4

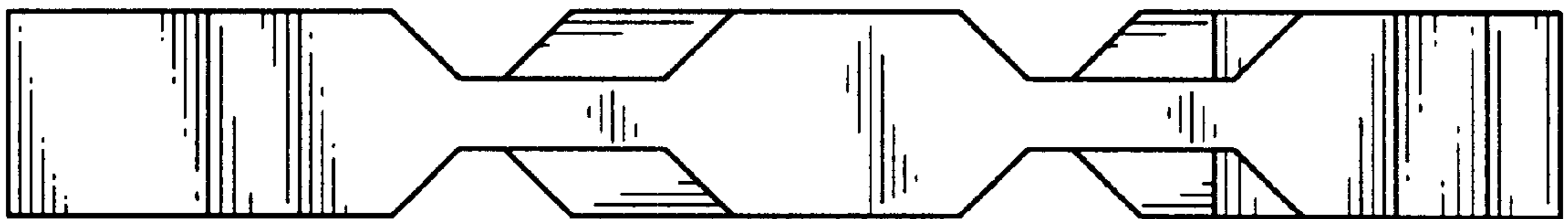

FIG. 5

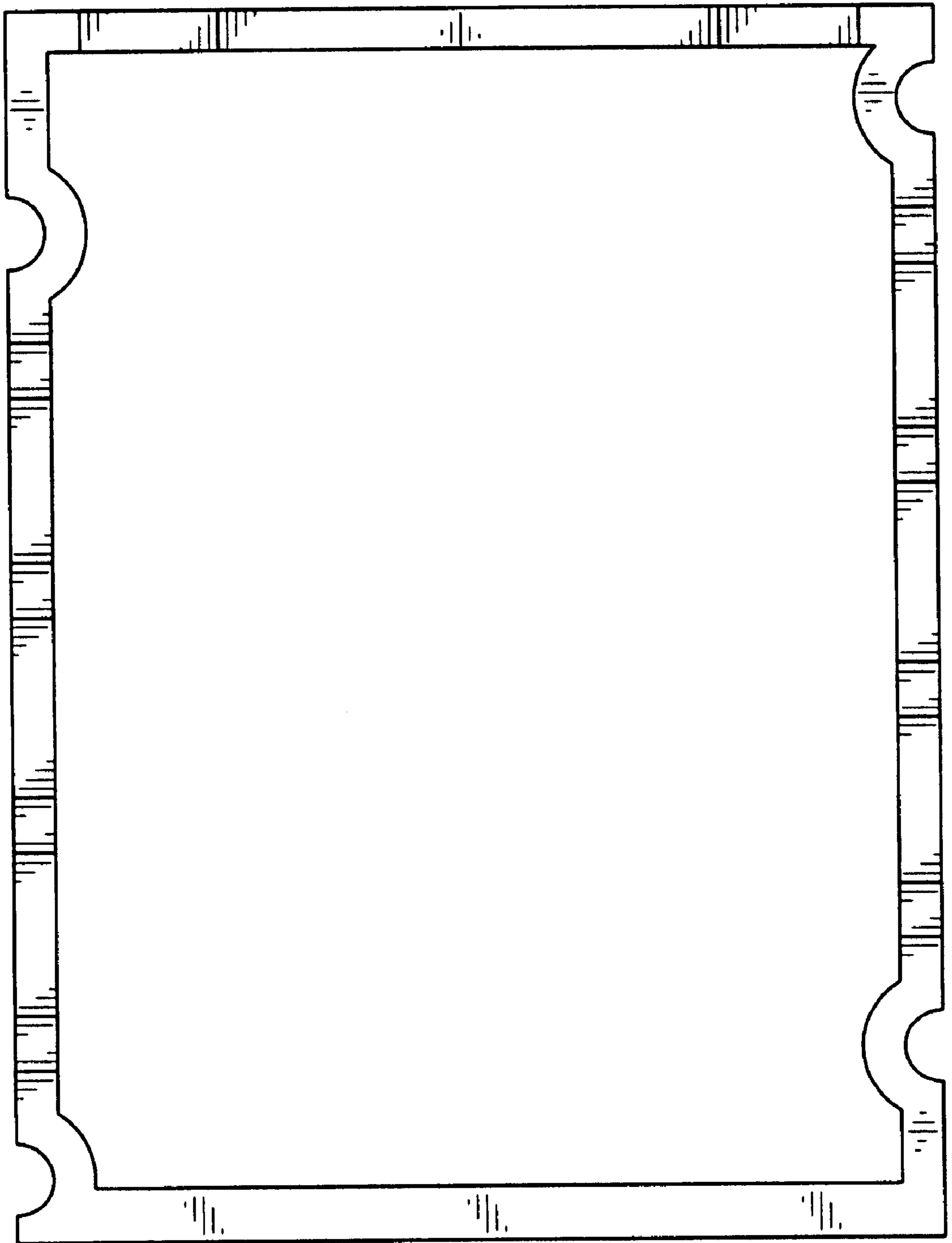

FIG. 6

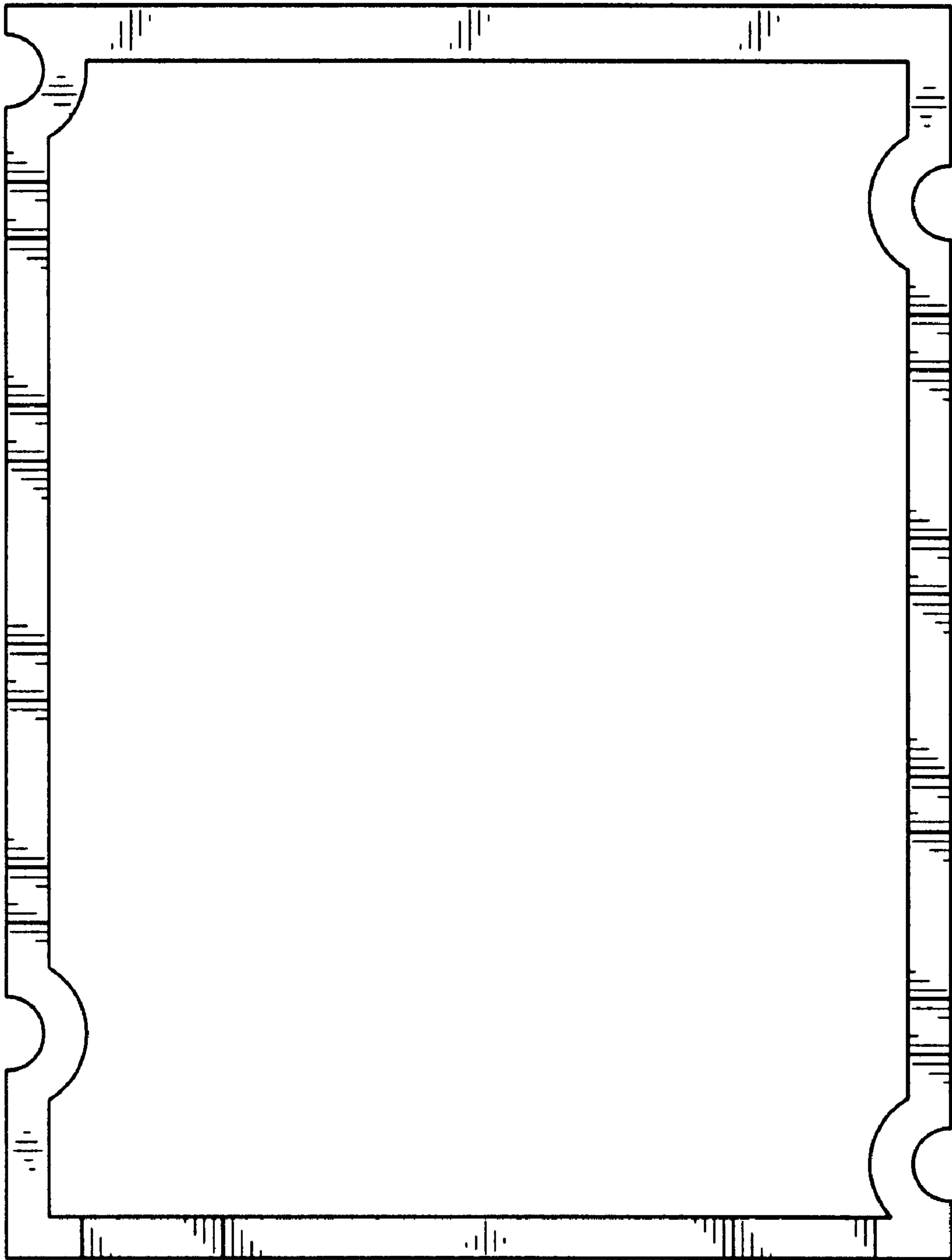

FIG. 7