



US00D463992S

(12) **United States Design Patent**
Tremmel

(10) **Patent No.:** **US D463,992 S**

(45) **Date of Patent:** **** Oct. 8, 2002**

(54) **ROADWAY REFLECTOR POST SYSTEM**

D439,855 S * 4/2001 Caldeira D10/109
D453,700 S * 2/2002 Tremmel D10/109

(76) Inventor: **Uwe Tremmel**, Steinheimer Str. 15,
D-70435 Stuttgart (DE)

* cited by examiner

(**) Term: **14 Years**

Primary Examiner—Marcus A. Jackson
(74) *Attorney, Agent, or Firm*—Laurence A. Greenberg;
Werner H. Stemer; Gregory L. Mayback

(21) Appl. No.: **29/150,694**

(22) Filed: **Nov. 27, 2001**

(57) **CLAIM**

The ornamental design for the roadway reflector post system, as shown and described.

Related U.S. Application Data

DESCRIPTION

(62) Division of application No. 29/124,520, filed on Jun. 7, 2000.

(51) **LOC (7) Cl.** **10-05**

(52) **U.S. Cl.** **D10/109**

(58) **Field of Search** D10/109, 111,
D10/113, 114; 116/63 C, 63 P, 63 R; 40/606,
607, 611, 612; 404/5-16

FIG. 1 is a right-side elevational view of a metallic support base with a round pipe support pole, with the pole broken away to indicate indeterminate length;
FIG. 2 is a front elevational view thereof;
FIG. 3 is a rear elevational view thereof;
FIG. 4 is a left-side elevational view thereof;
FIG. 5 is a top plan view thereof; and,
FIG. 6 is a bottom plan view thereof.

(56) **References Cited**

U.S. PATENT DOCUMENTS

D424,961 S * 5/2000 Dolfin D10/109

1 Claim, 2 Drawing Sheets

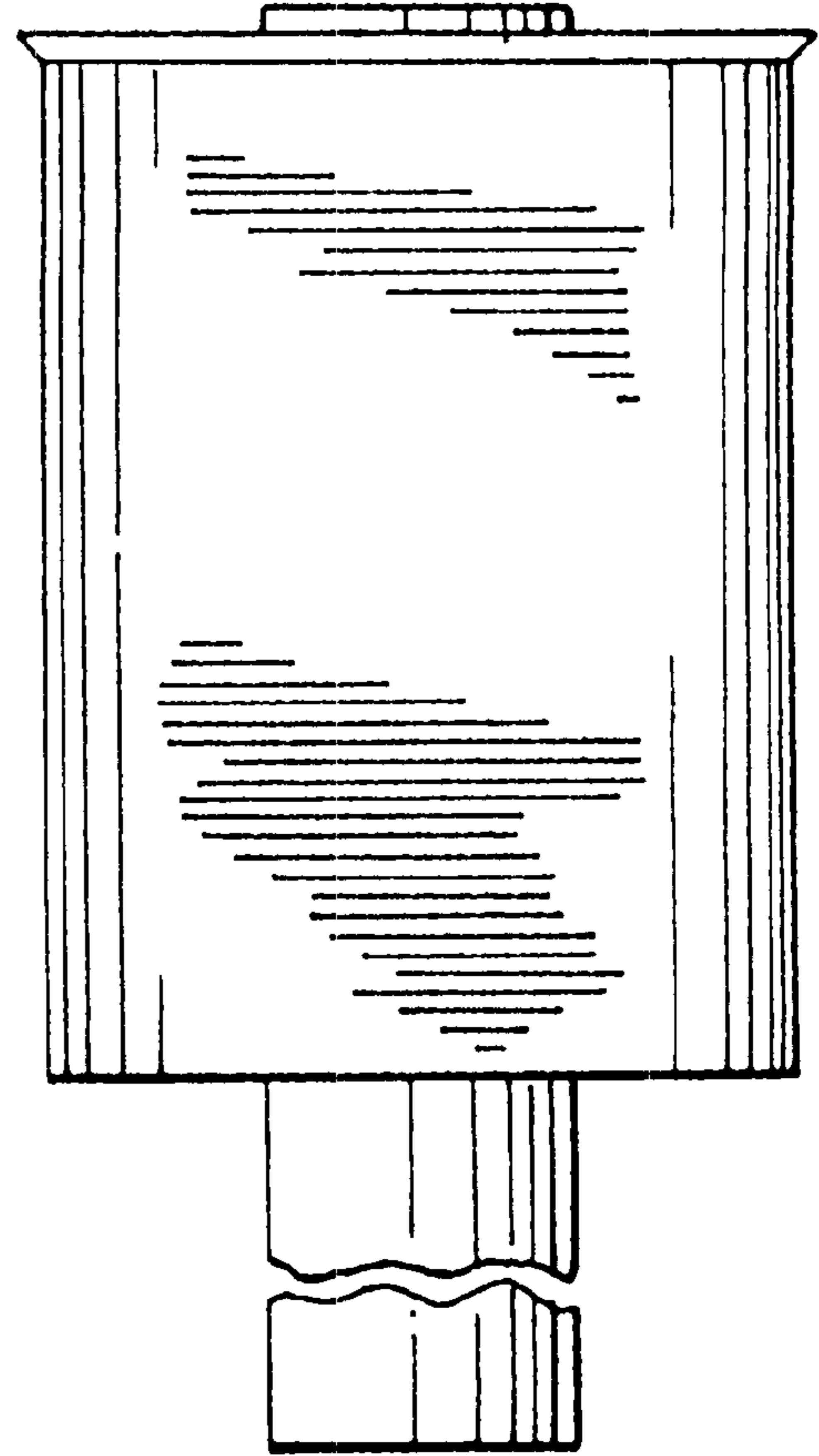
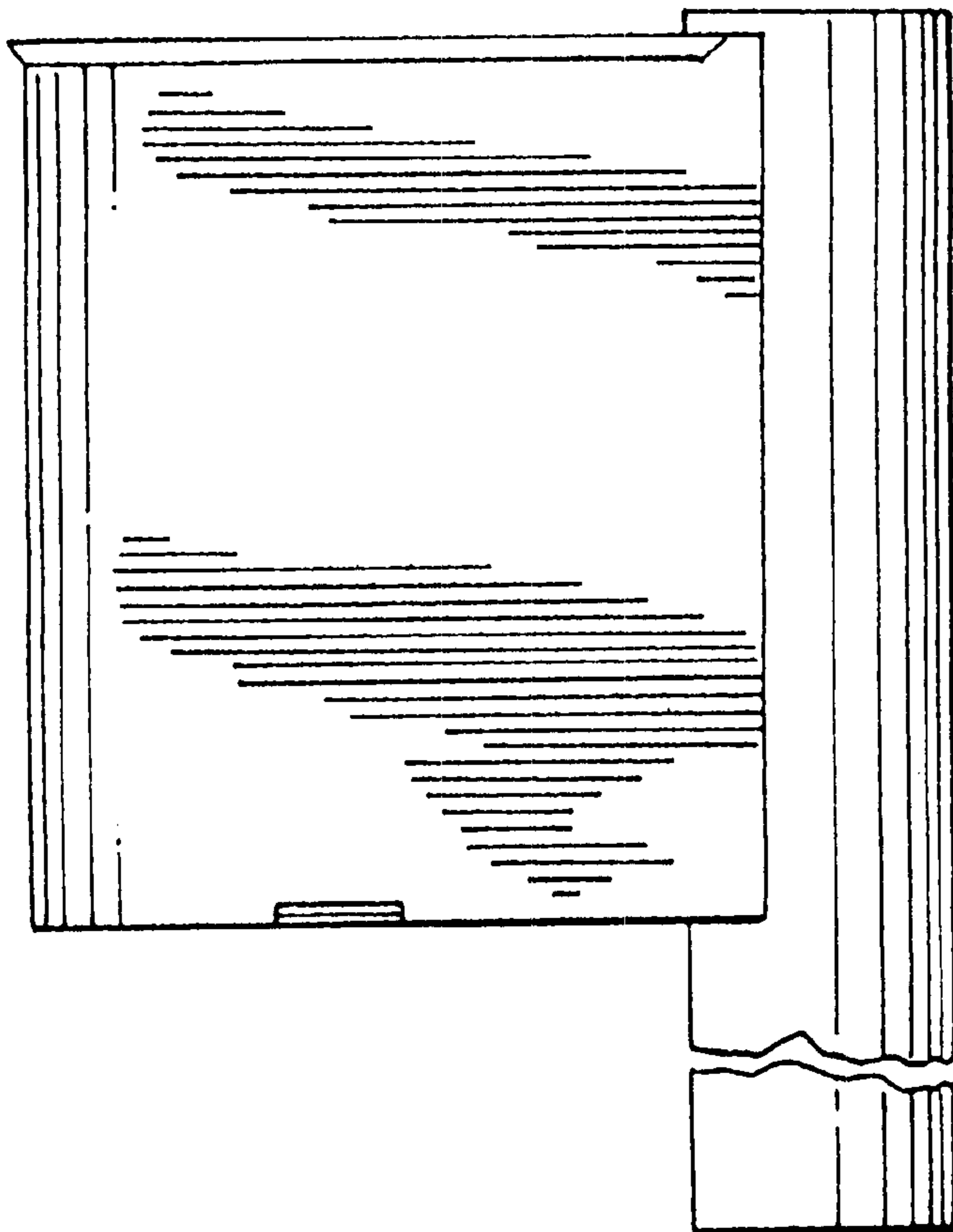

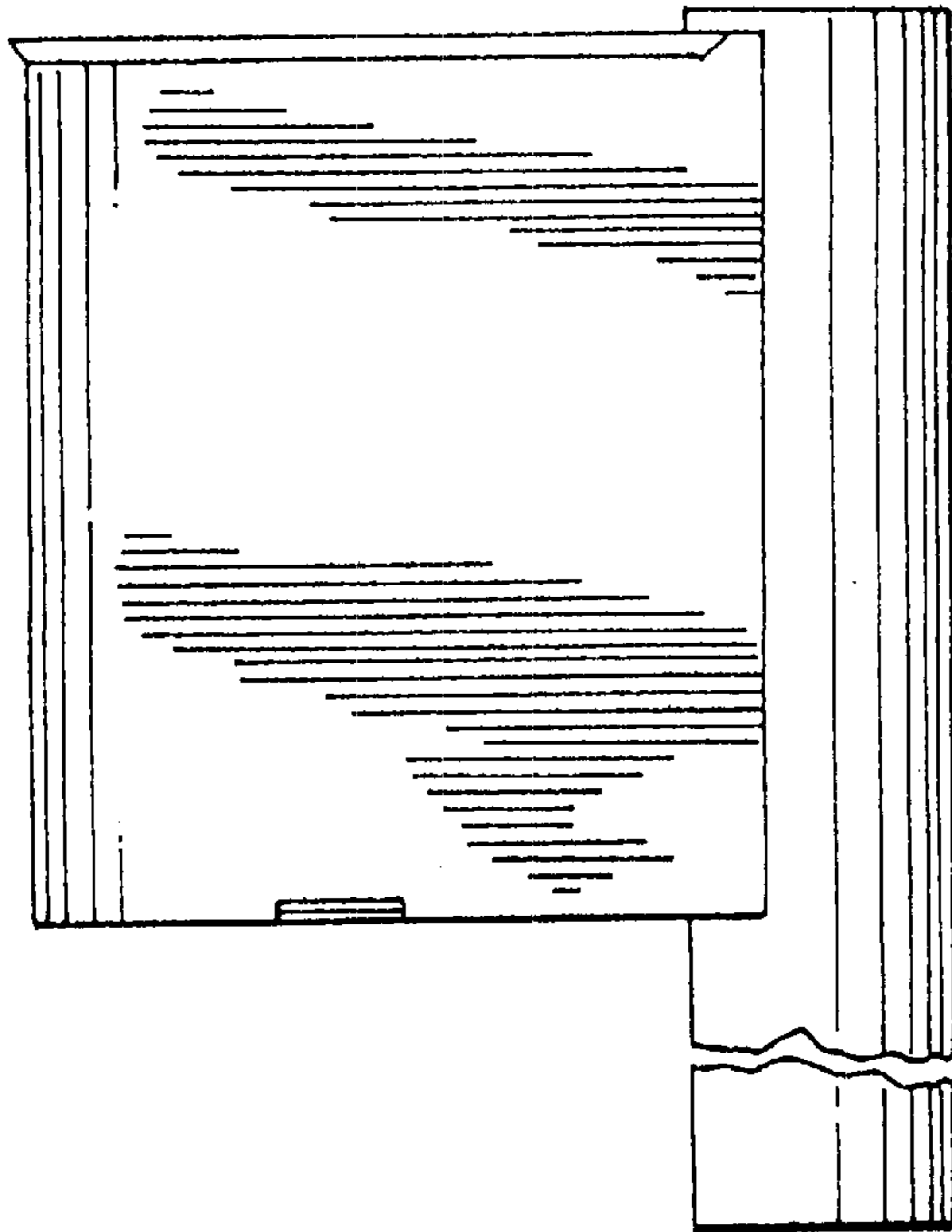

Fig. 1

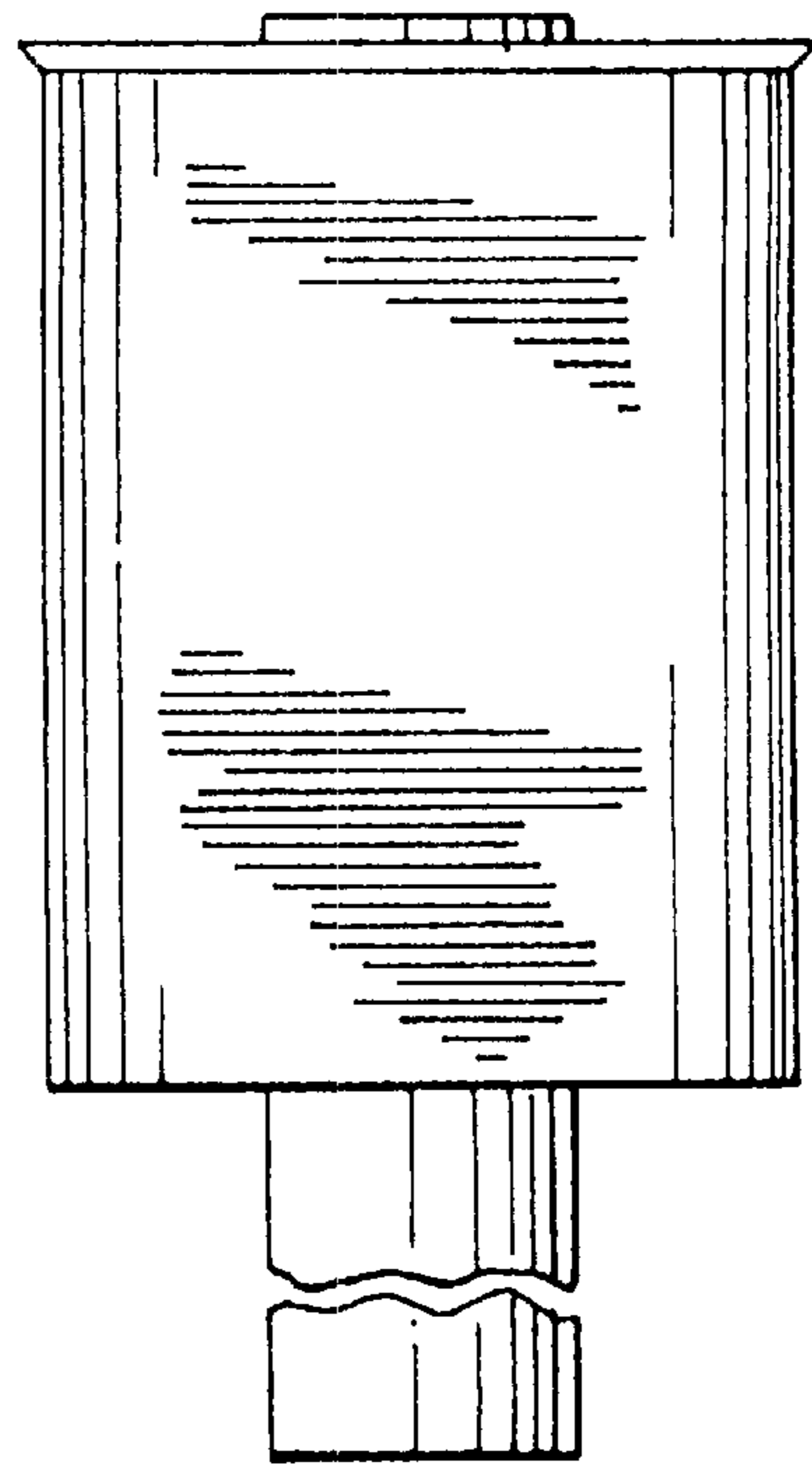

Fig. 2

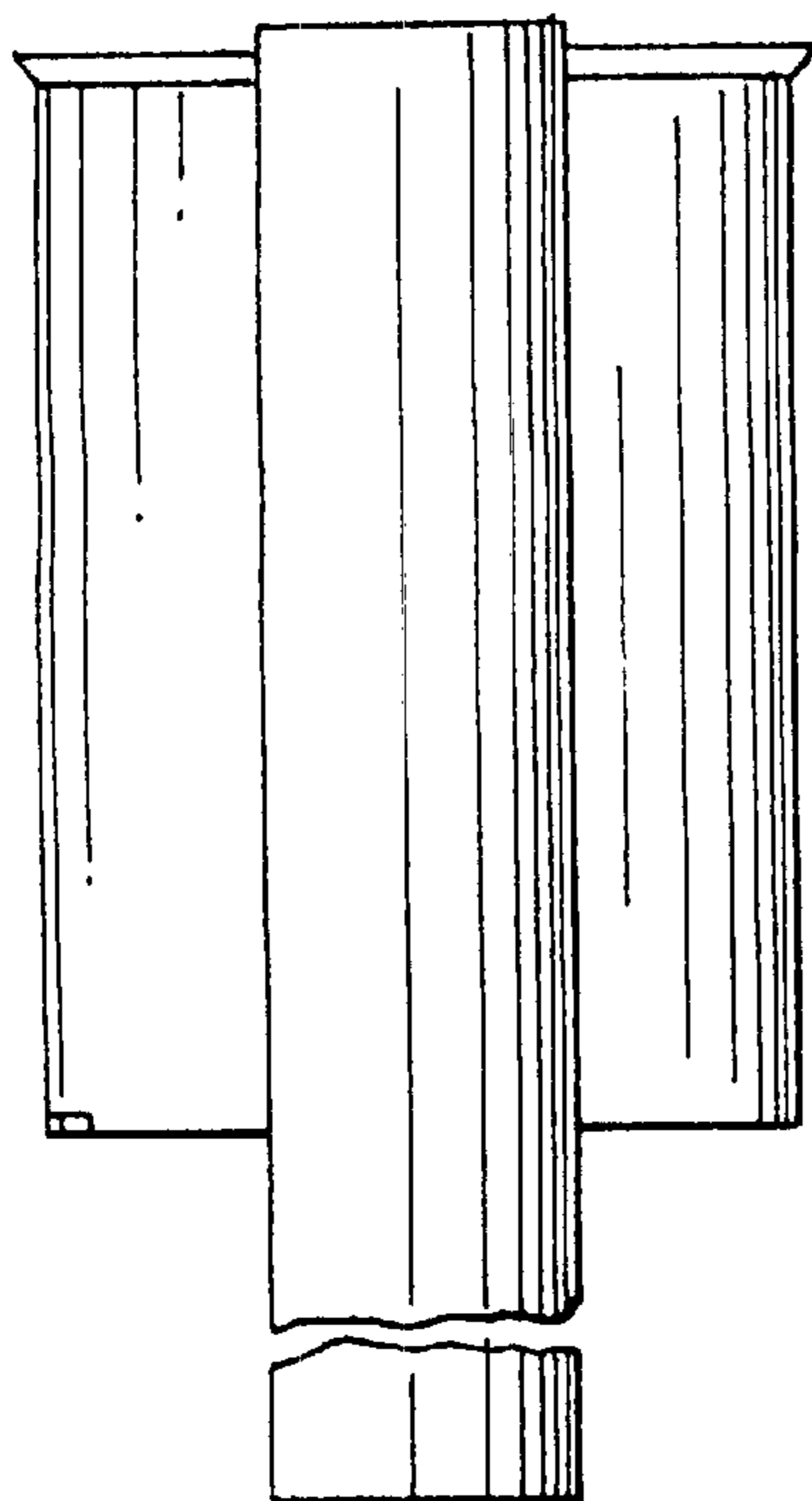

Fig. 3

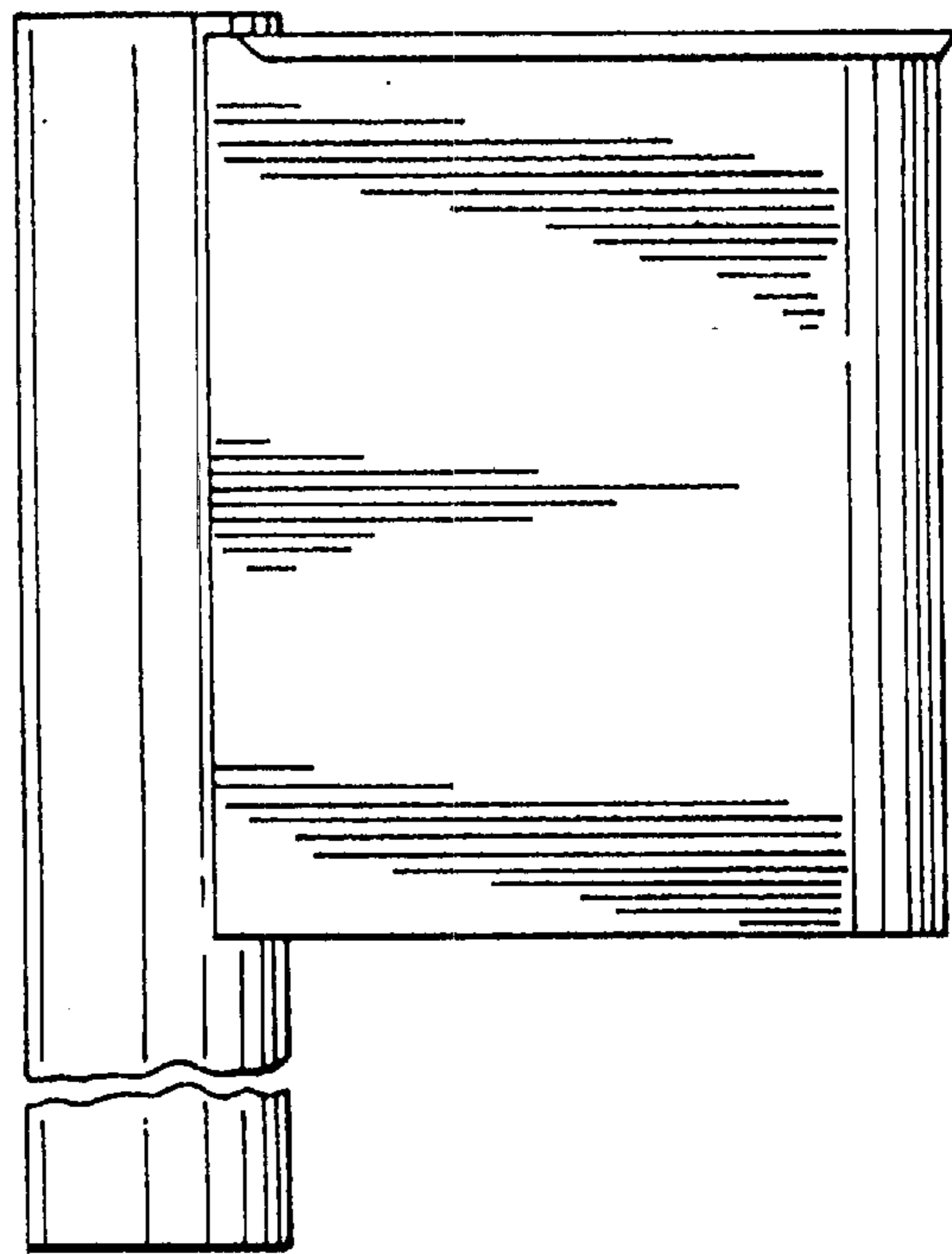

Fig. 4

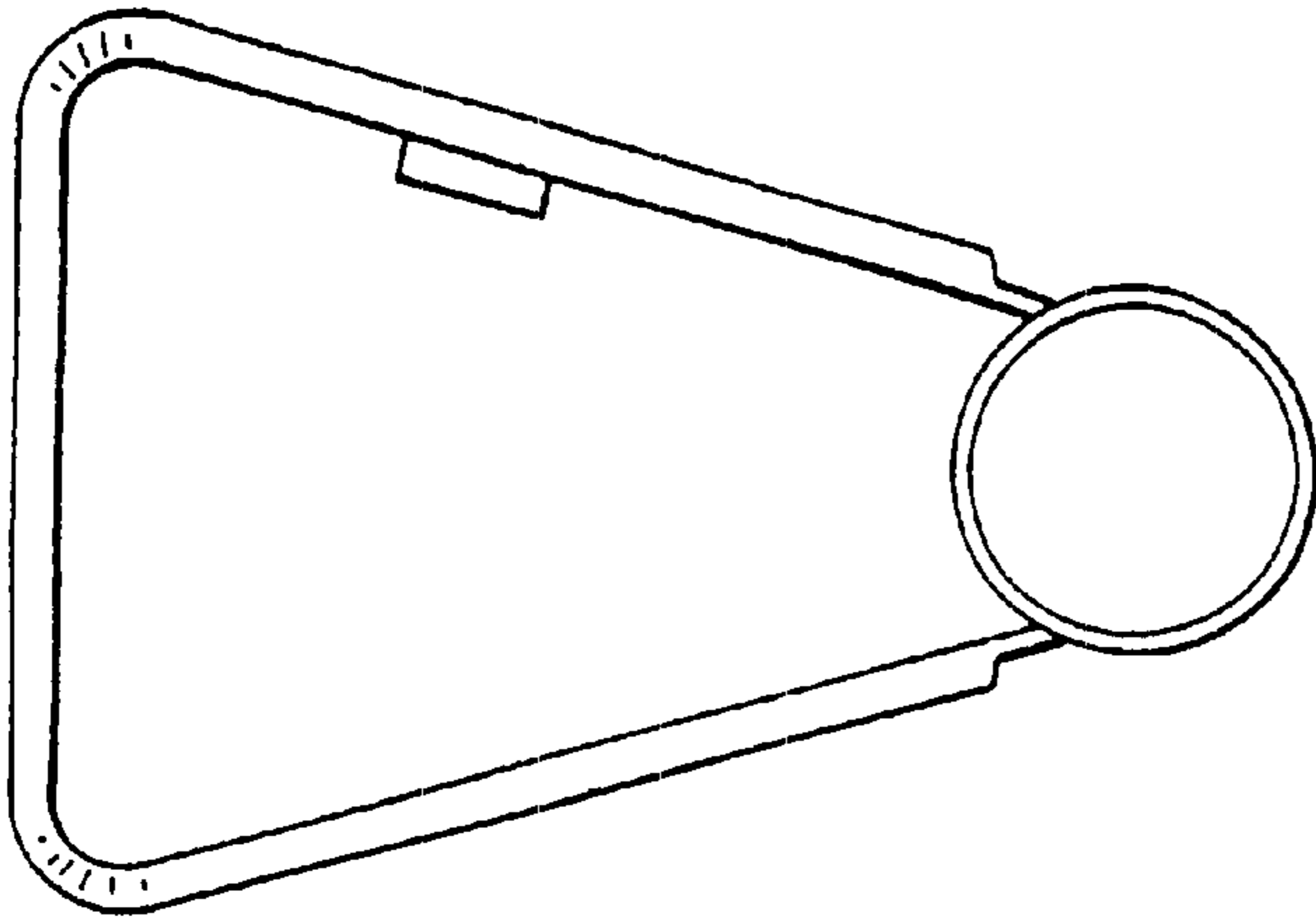

Fig. 5

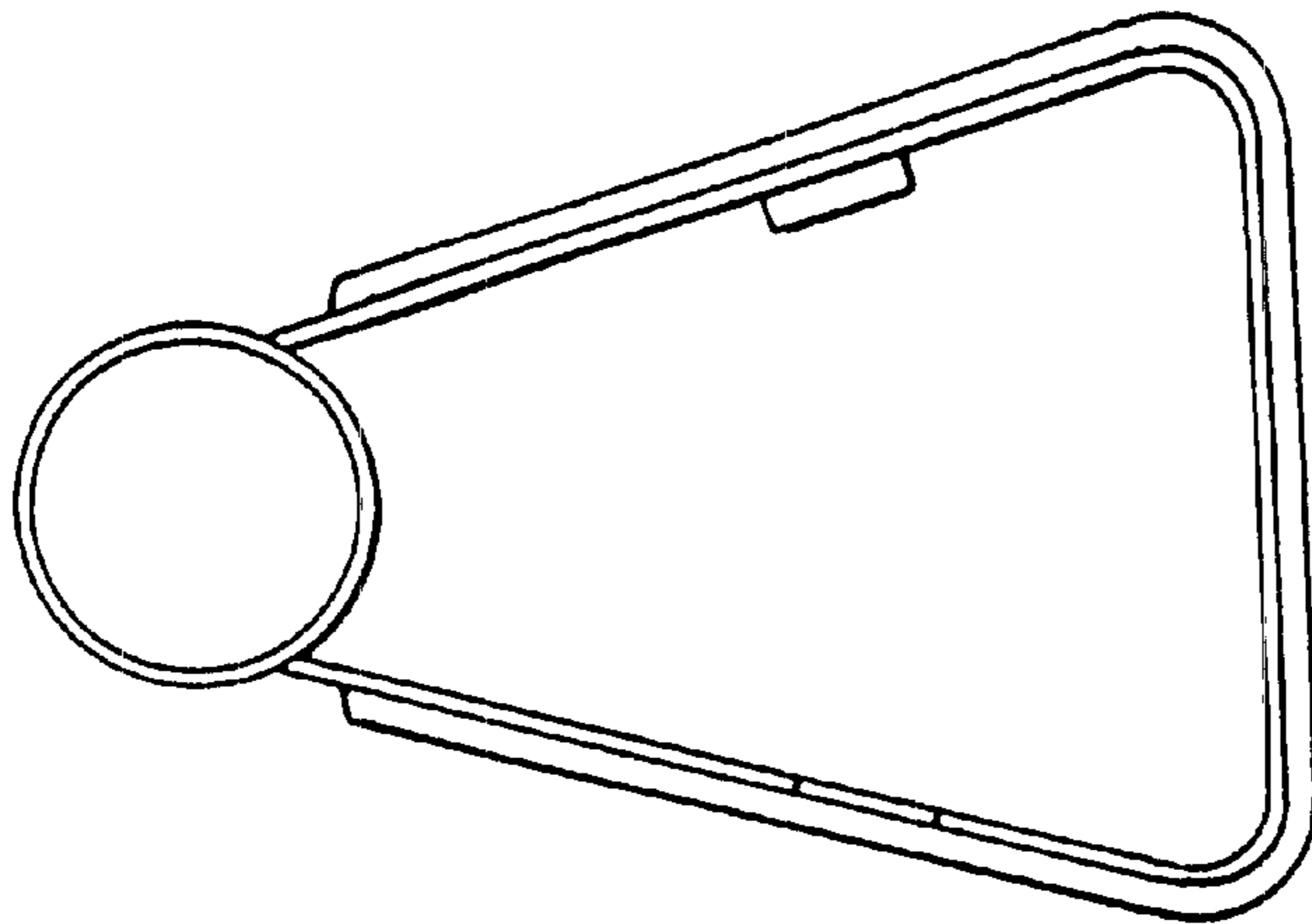

Fig. 6