



US00D463805S

(12) **United States Design Patent**  
**Witte et al.**

(10) **Patent No.:** **US D463,805 S**

(45) **Date of Patent:** **\*\* Oct. 1, 2002**

(54) **TRACTOR**

(75) Inventors: **Benjamin M. Witte**, Fairbank, IA (US);  
**Robert J. Recker**, Waterloo, IA (US);  
**Mervin P. Kizlyk**, Cedar Falls, IA  
(US); **Barrie L. Smith**, Moline, IL  
(US); **Daniel G. Niebuhr**, Fairbank, IA  
(US); **Michael O. Youngblood**, Cedar  
Falls, IA (US); **Gary Vandebark**, East  
Markleville, IN (US); **Ryan Libler**,  
Anderson, IN (US); **Kevin Augustin**,  
Greenwood, IN (US); **Curt Jensen**,  
Fort Mill, SC (US); **James Nagorcka**,  
Hamilton (AU)

(73) Assignee: **Deere & Company**, Moline, IL (US)

(\*\*) Term: **14 Years**

(21) Appl. No.: **29/143,120**

(22) Filed: **Jun. 7, 2001**

(51) **LOC (7) Cl.** ..... **12-09**

(52) **U.S. Cl.** ..... **D15/23**

(58) **Field of Search** ..... D15/10, 22, 23,  
D15/26; 180/89.12; 56/13.7, 14.9, 6; 111/109,  
136, 926

(56) **References Cited**

**U.S. PATENT DOCUMENTS**

3,601,958 A	*	8/1971	Roof	.....	56/13.7
4,438,710 A	*	3/1984	Paladino	.....	111/109
D422,606 S	*	4/2000	Katoh	.....	D15/23
D442,972 S	*	5/2001	Wolf	.....	D15/15

\* cited by examiner

*Primary Examiner*—Mitchell Siegel

(57) **CLAIM**

The ornamental design for a tractor, as shown and described.

**DESCRIPTION**

FIG. 1 is an elevated front perspective view of a tractor showing the new design.

FIG. 2 is a top view of the tractor design of FIG. 1.

FIG. 3 is a right side view of the tractor design of FIG. 1.

FIG. 4 is a left side view of the tractor design of FIG. 1.

FIG. 5 is a front view of the tractor design of FIG. 1; and,

FIG. 6 is a rear view of the tractor design of FIG. 1.

The broken line showing is for illustrative purposes only and forms no part of the claimed design.

**1 Claim, 6 Drawing Sheets**

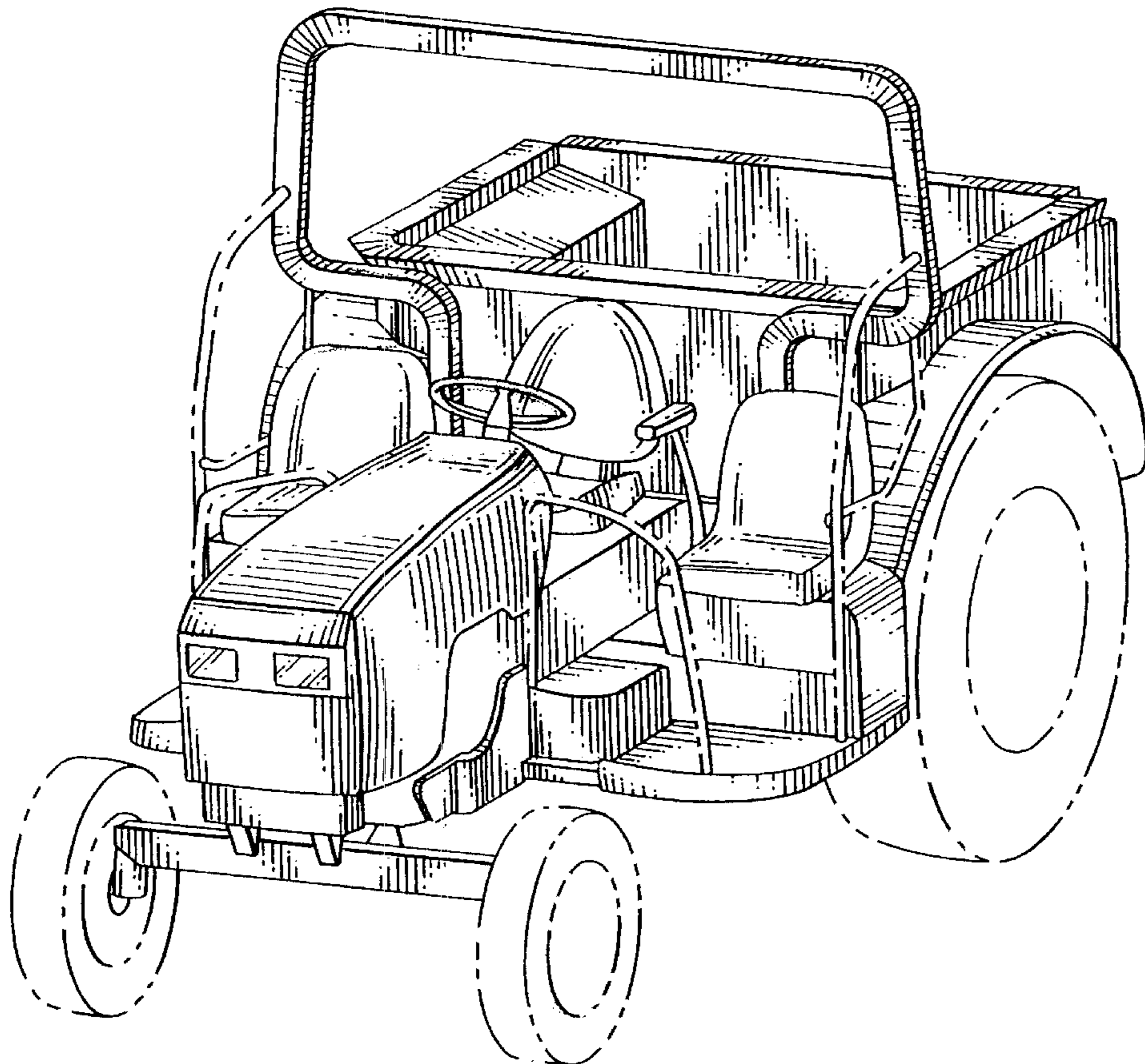

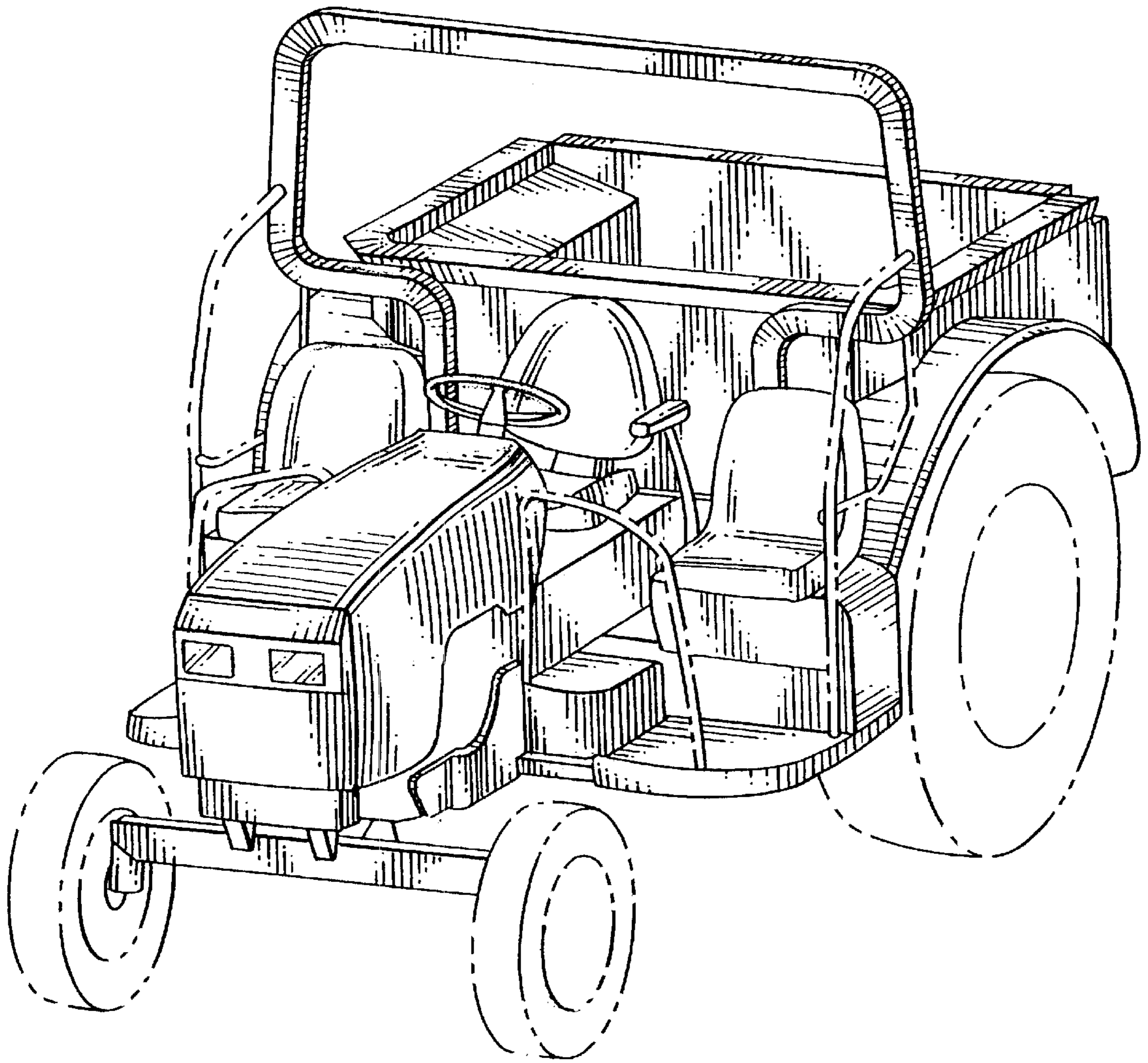

*Fig. 1*

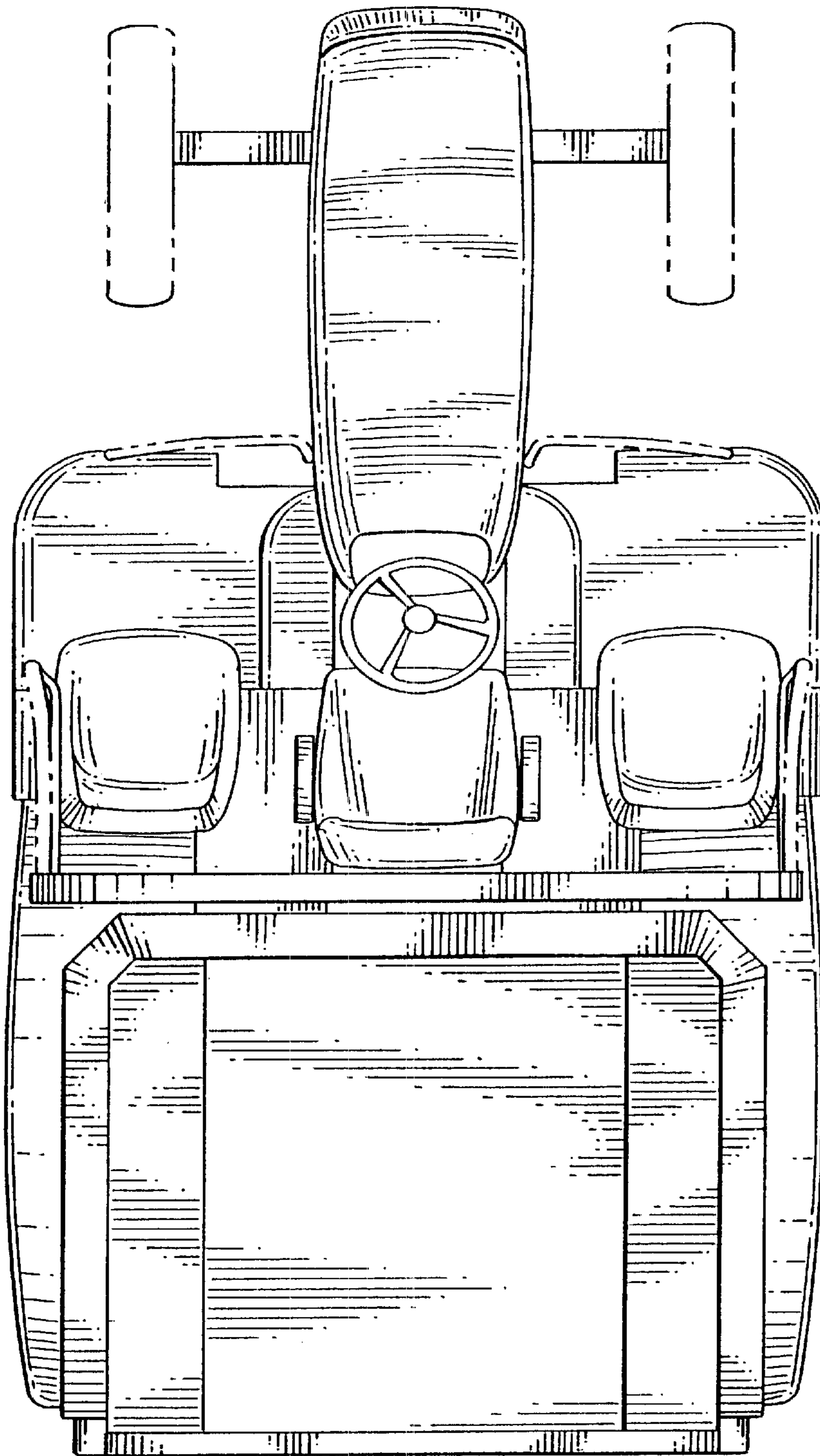
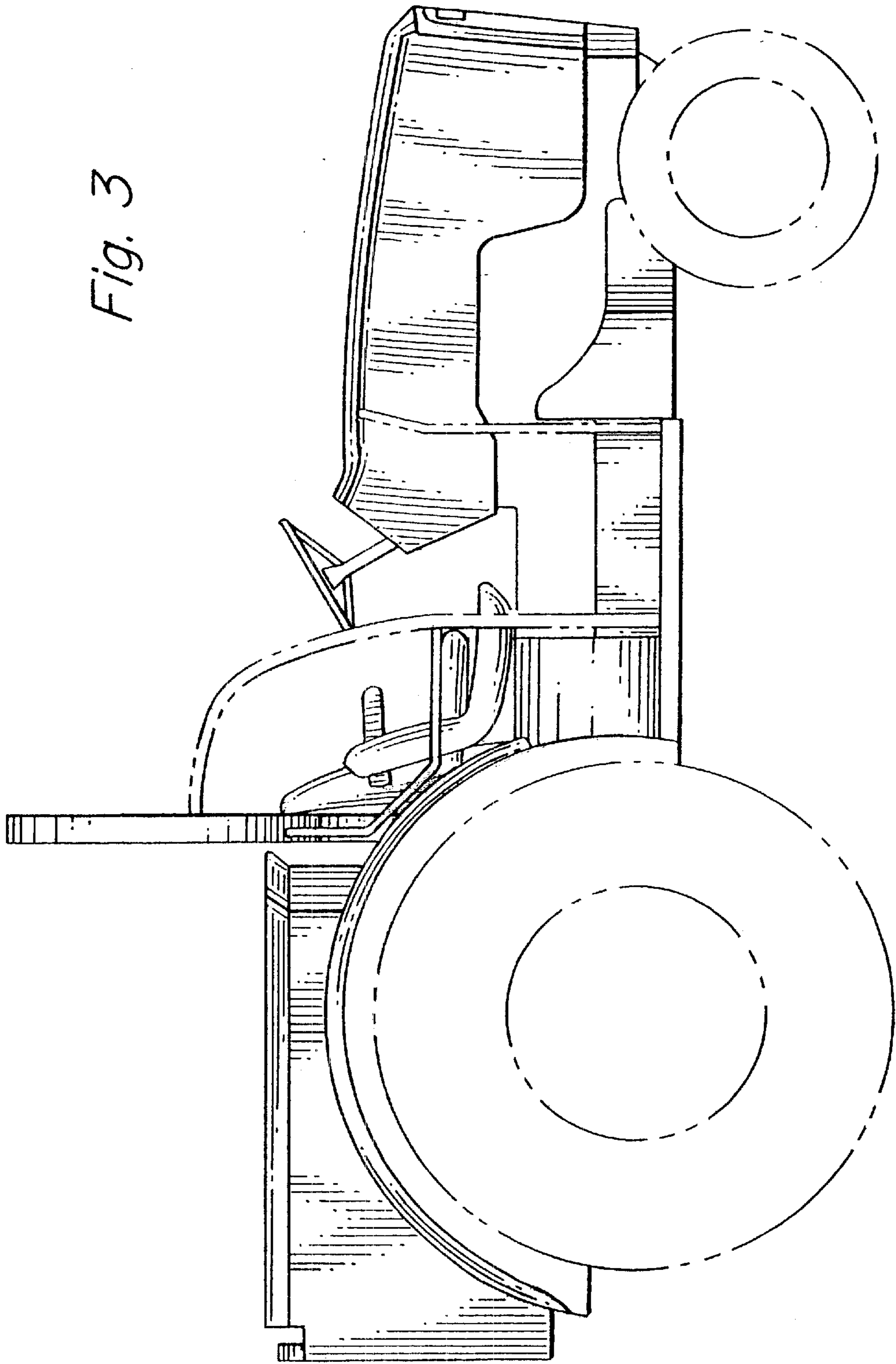

Fig. 2



*Fig. 3*



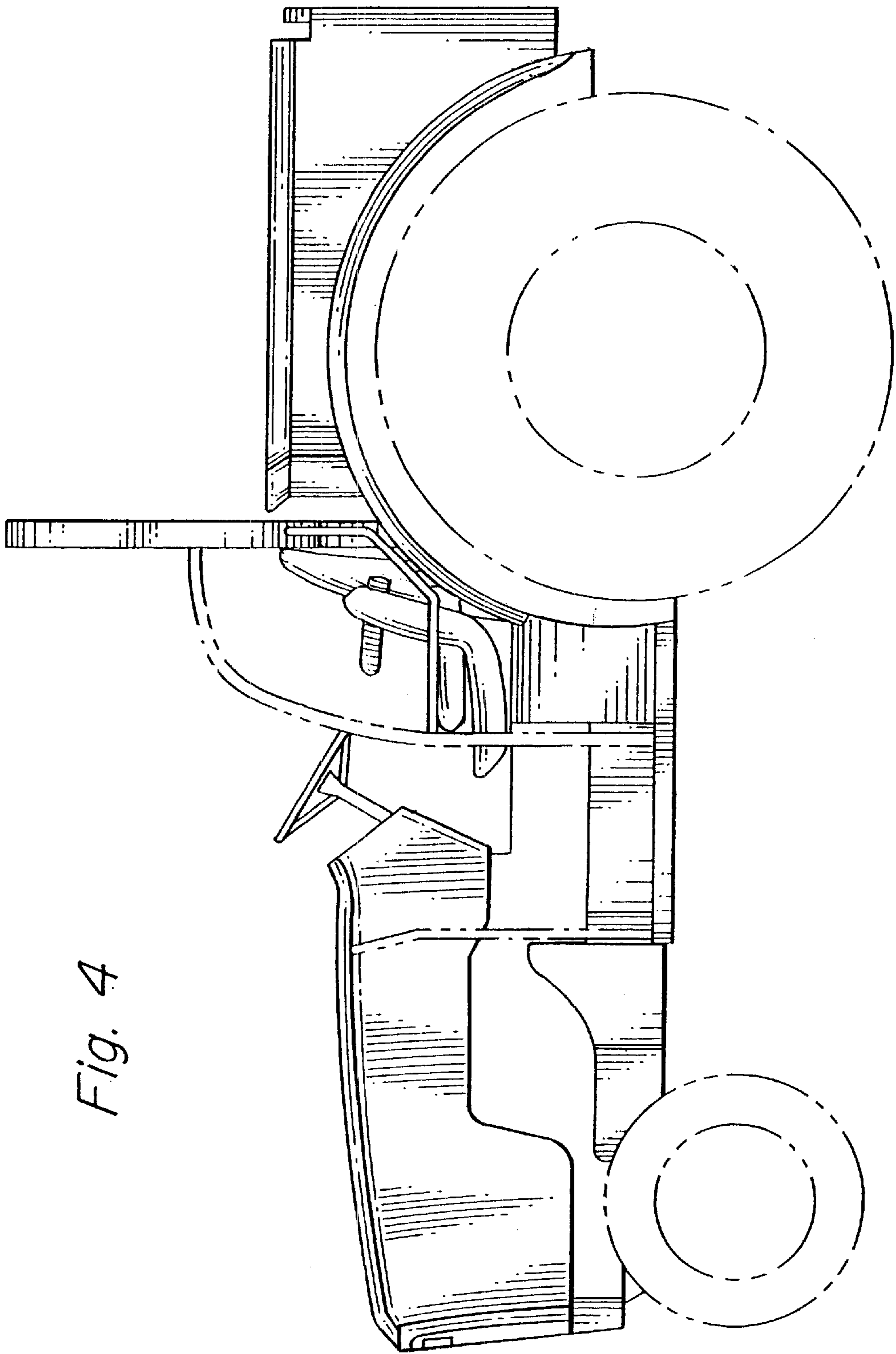
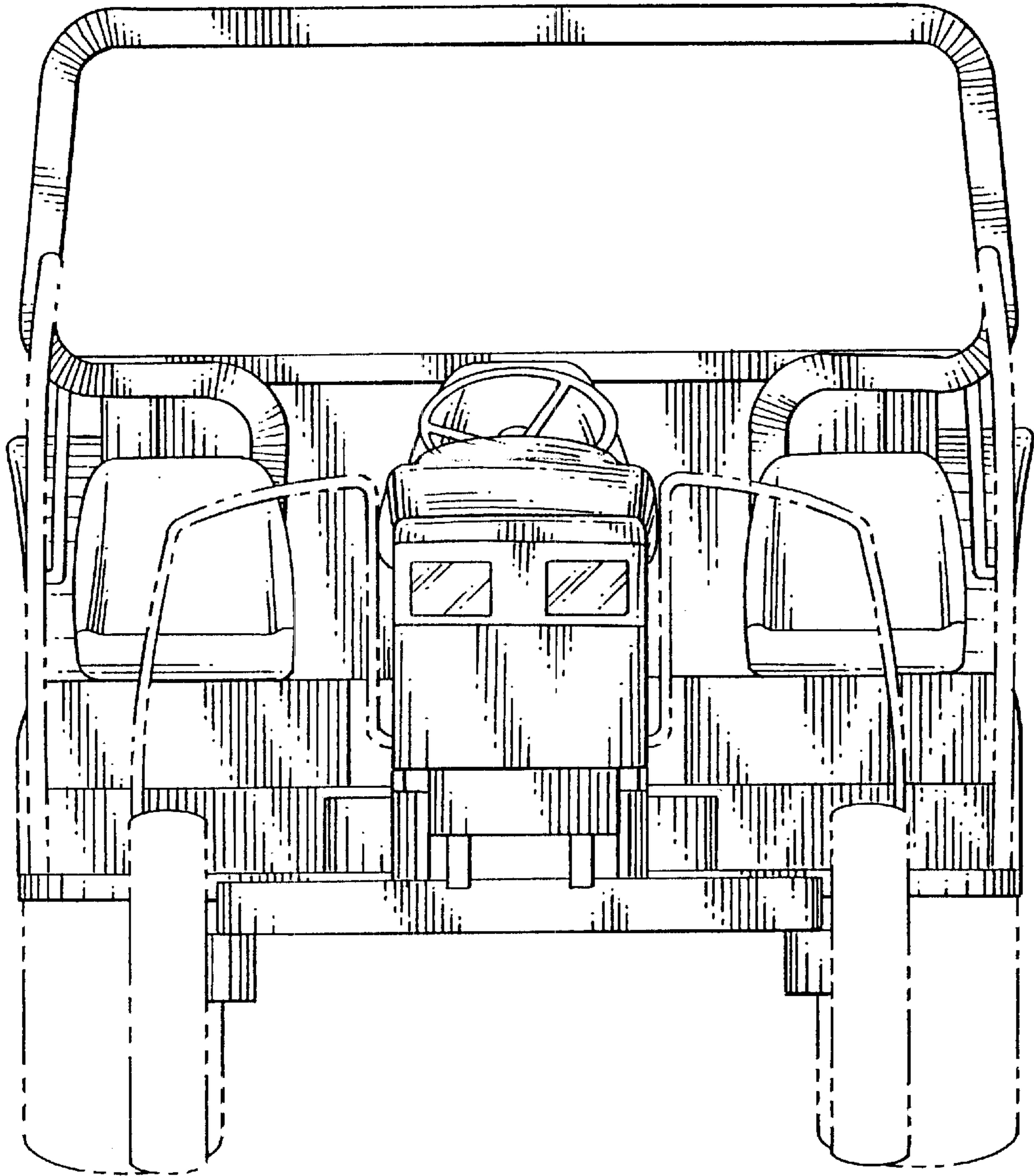
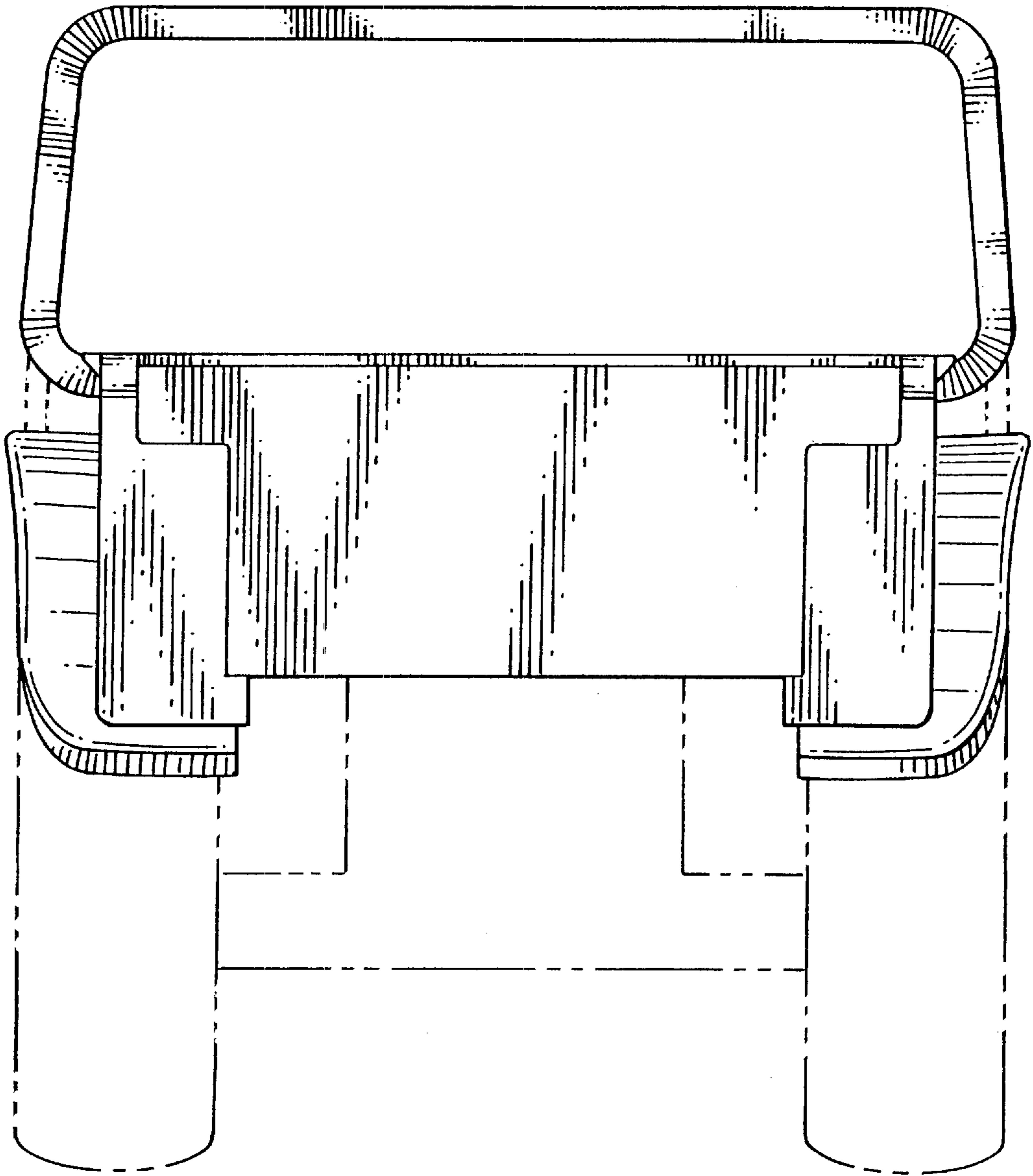

Fig. 4



*Fig. 5*



*Fig. 6*