



US00D463759S

(12) **United States Design Patent**
Okonkwo

(10) **Patent No.:** **US D463,759 S**

(45) **Date of Patent:** **** Oct. 1, 2002**

(54) **MODERN PICK-UP TRUCK BODY**

(75) Inventor: **Chidi Okonkwo**, 670 McGill Pl.,
Atlanta, GA (US) 30312

(73) Assignee: **Chidi Okonkwo**, Atlanta, GA (US)

(**) Term: **14 Years**

(21) Appl. No.: **29/153,871**

(22) Filed: **Jan. 15, 2002**

(51) **LOC (7) Cl.** **12-08**

(52) **U.S. Cl.** **D12/98**

(58) **Field of Search** D12/98, 93, 96;
296/183, 24.1, 37.6

(56) **References Cited**

U.S. PATENT DOCUMENTS

D396,666 S	*	8/1998	Allen	D12/98
D405,392 S	*	2/1999	Allen	D12/98
D411,969 S	*	7/1999	Gerisch et al.	D12/98
D430,068 S	*	8/2000	Castiglione et al.	D12/98

* cited by examiner

Primary Examiner—Melody N. Brown

(57) **CLAIM**

The ornamental design for a modern pick-up truck body, as shown and described.

DESCRIPTION

FIG. 1 is a front perspective view of the modern pick-up truck body, showing the new design.

FIG. 2 is a rear perspective view of the modern pick-up truck body shown in FIG. 1.

FIG. 3 is a side view of the modern pick-up truck body shown in FIG. 1.

FIG. 4 is a top plan view of the modern pick-up truck body shown in FIG. 1.

FIG. 5 is a rear perspective view of the modern pick-up truck body shown in FIG. 1, with the left door opened, and both cargo access panels opened (alternate positions).

FIG. 6 is a rear perspective view of the modern pick-up truck body shown in FIG. 1, with the Cargo bed lid opened, and the rear gate opened (alternate positions).

FIG. 7 is a rear perspective view of the modern pick-up truck body shown in FIG. 1, with the Cargo bed lid folded once, and the rear gate opened (alternate positions).

FIG. 8 is a rear perspective view of the modern pick-up truck body shown in FIG. 1, with the Cargo bed lid folded for the second time, to conceal it, and the rear gate opened (alternate positions).

FIG. 9 is a front view of the modern pick-up truck body shown in FIG. 1; and,

FIG. 10 is a rear view of the modern pick-up truck body shown in FIG. 1.

It will be understood that the broken lines showing tires and wheels through out the drawings are for illustrative purposes only and does not form any part of the subject design.

1 Claim, 6 Drawing Sheets

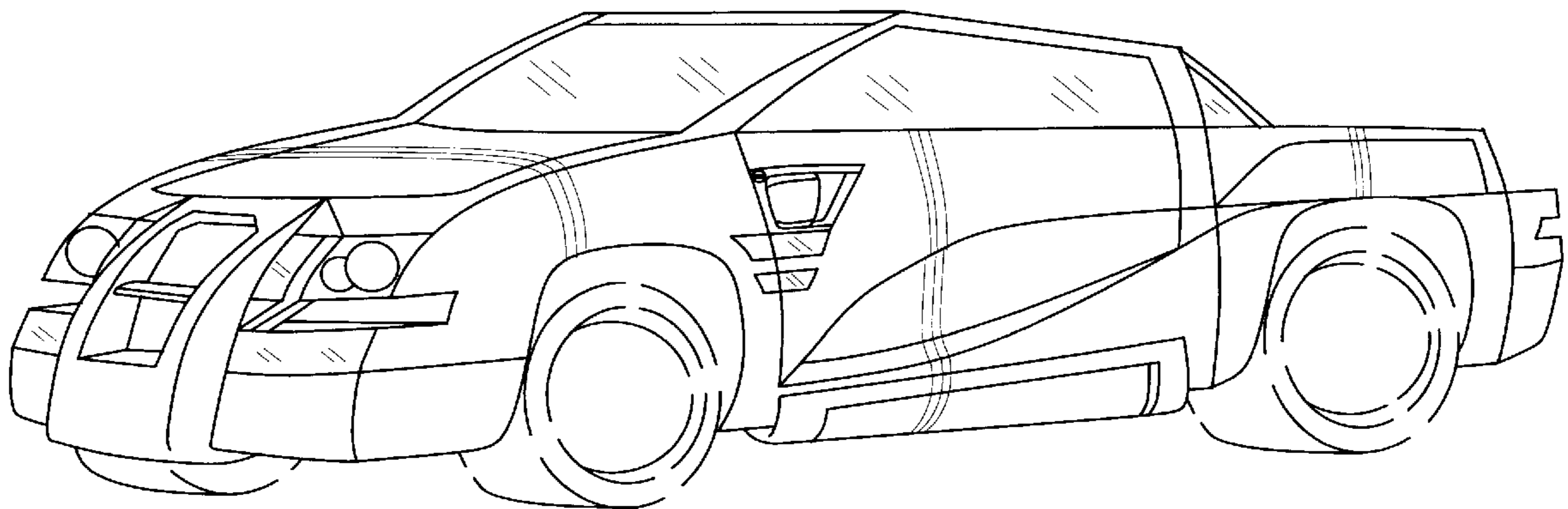

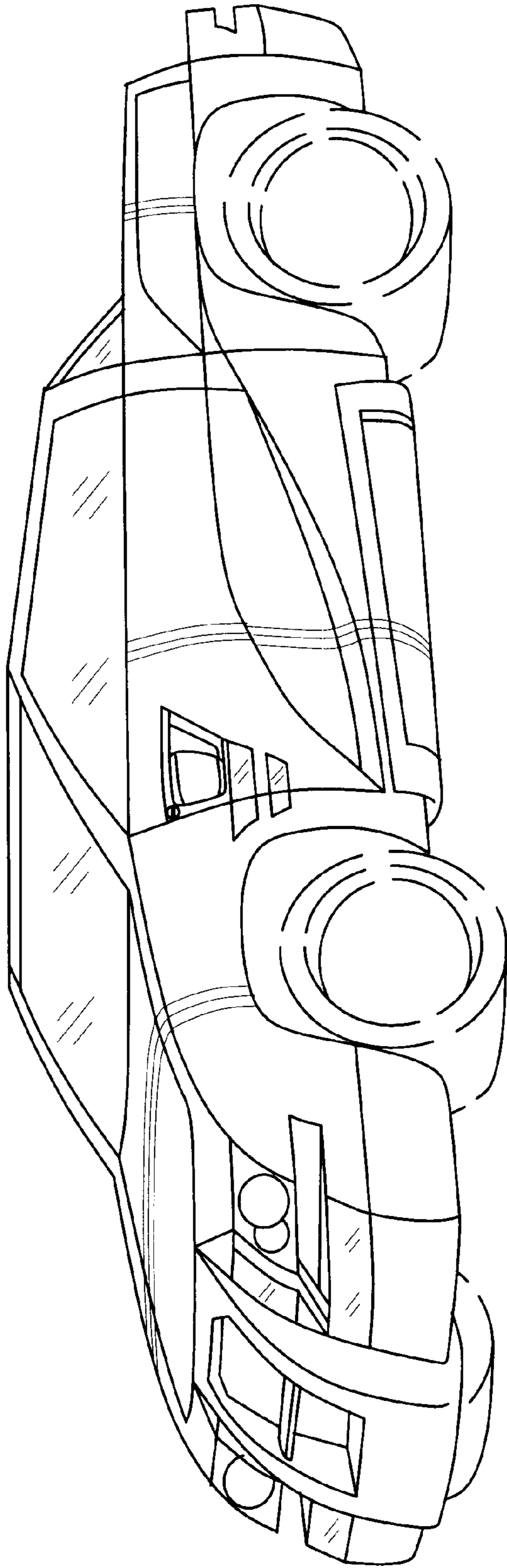

Fig - 1

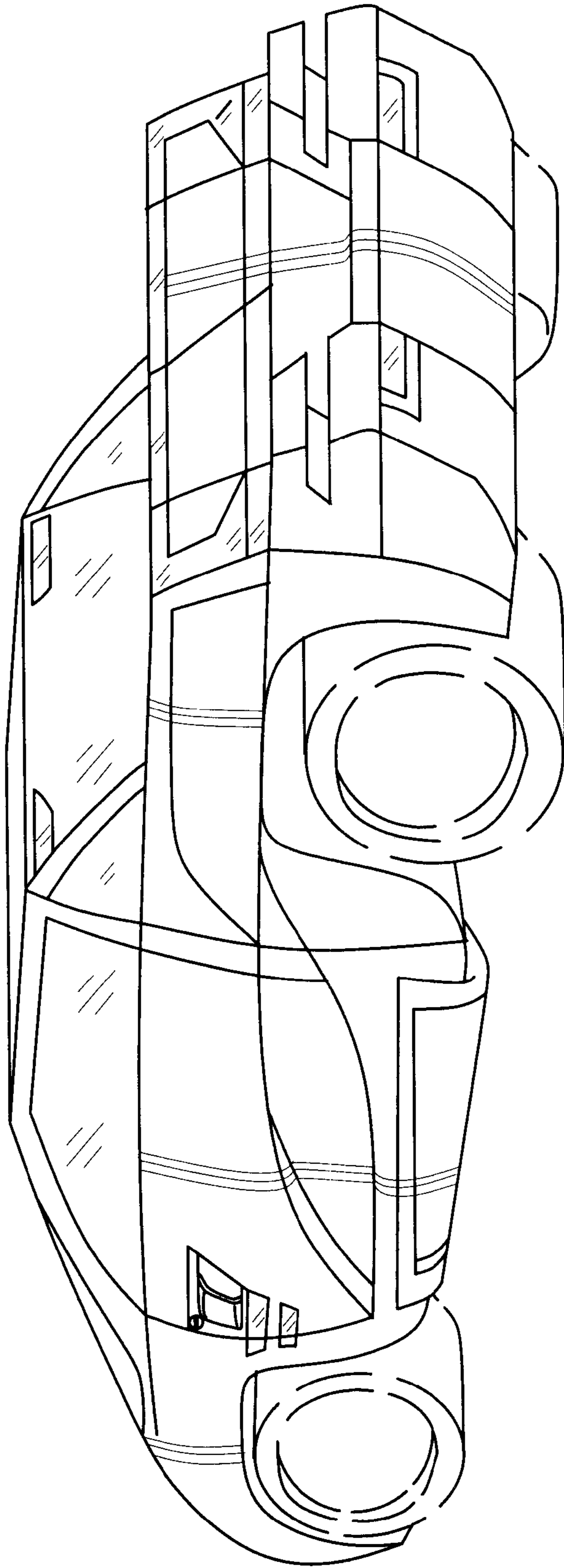

Fig - 2

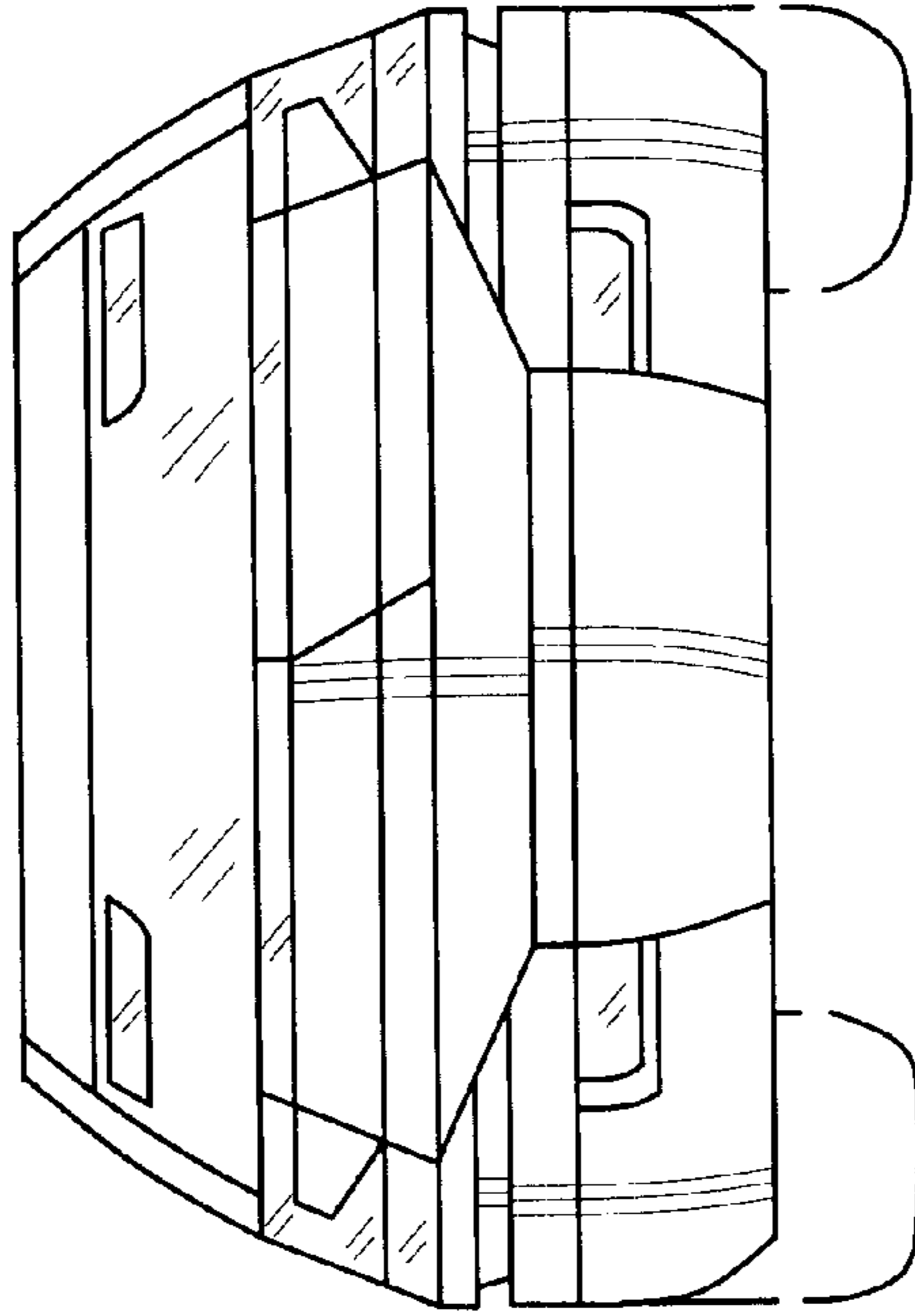

Fig - 4

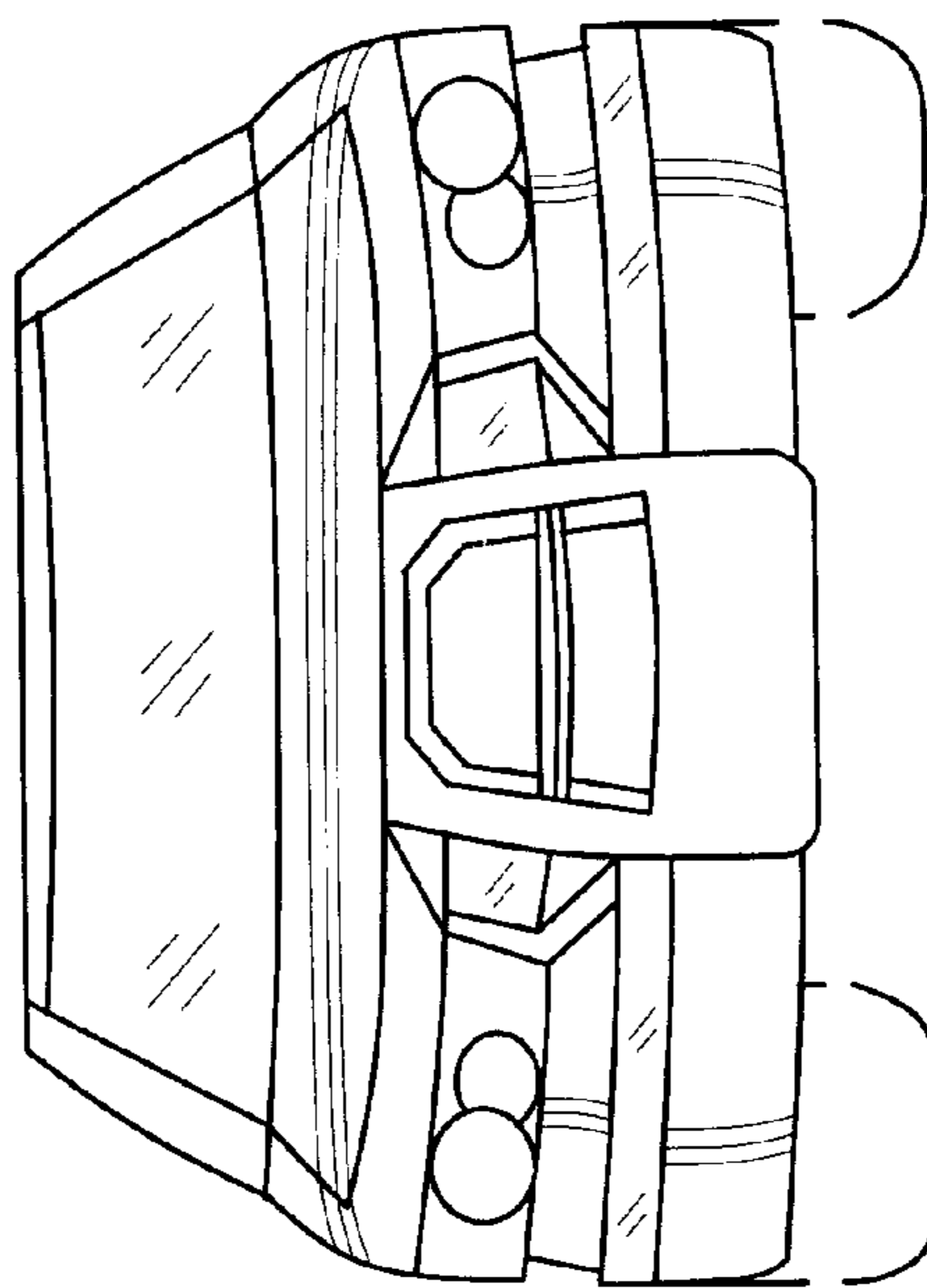

Fig - 3

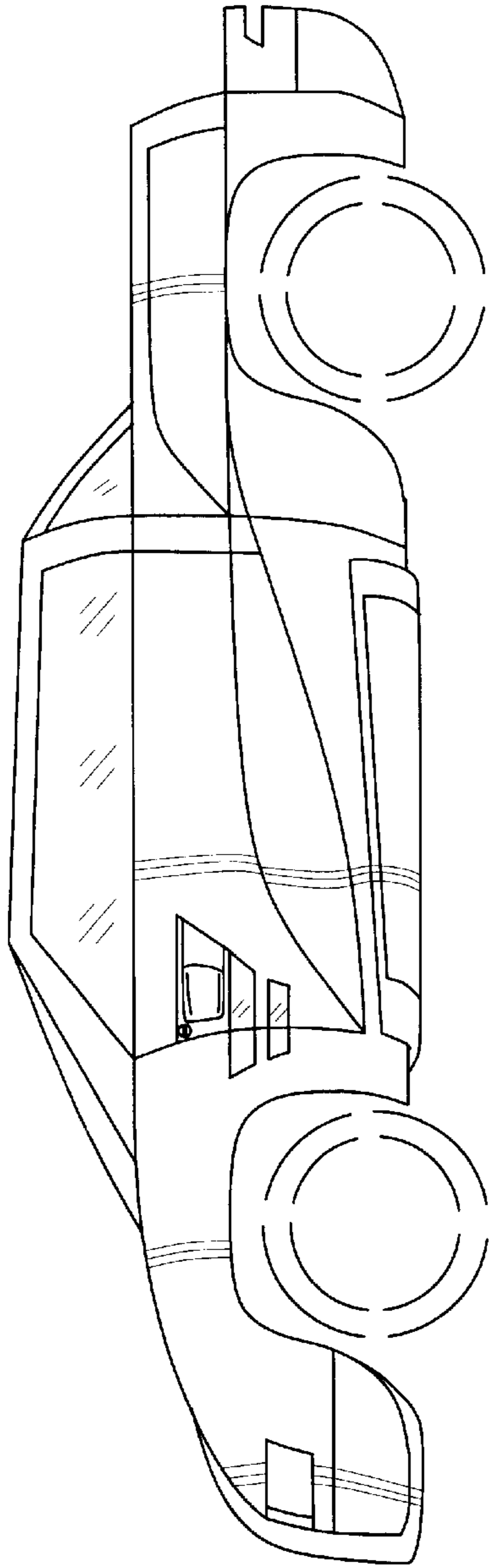

Fig - 5

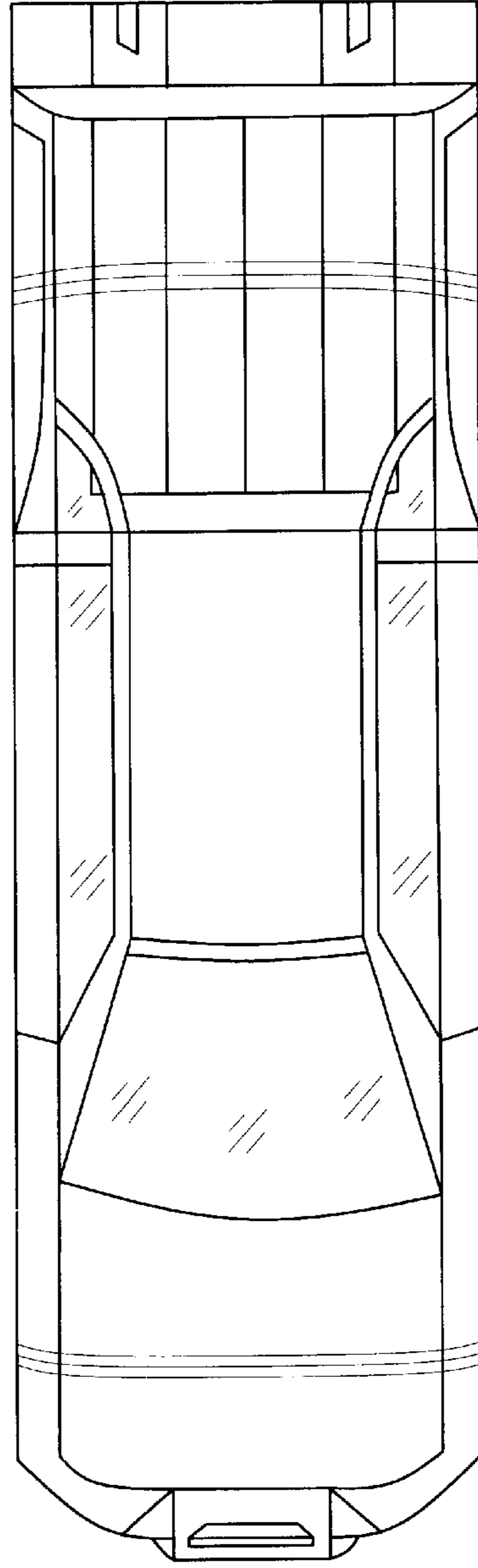

Fig - 6

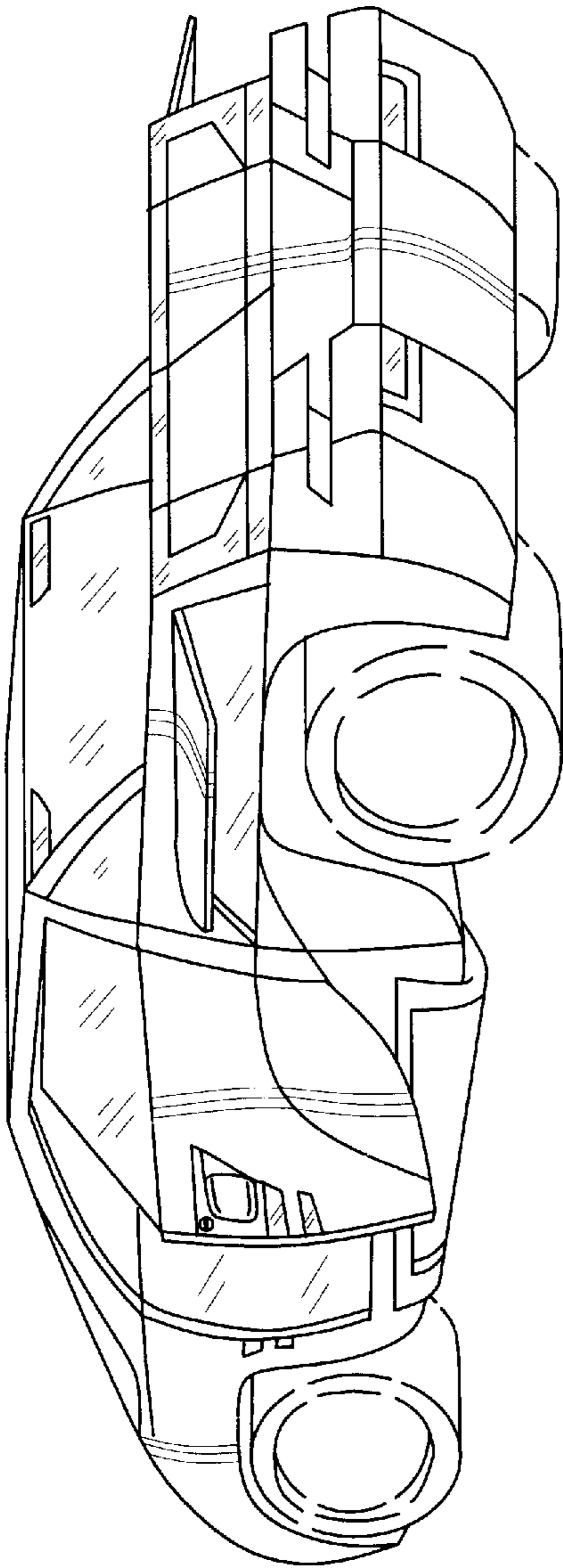

Fig - 7

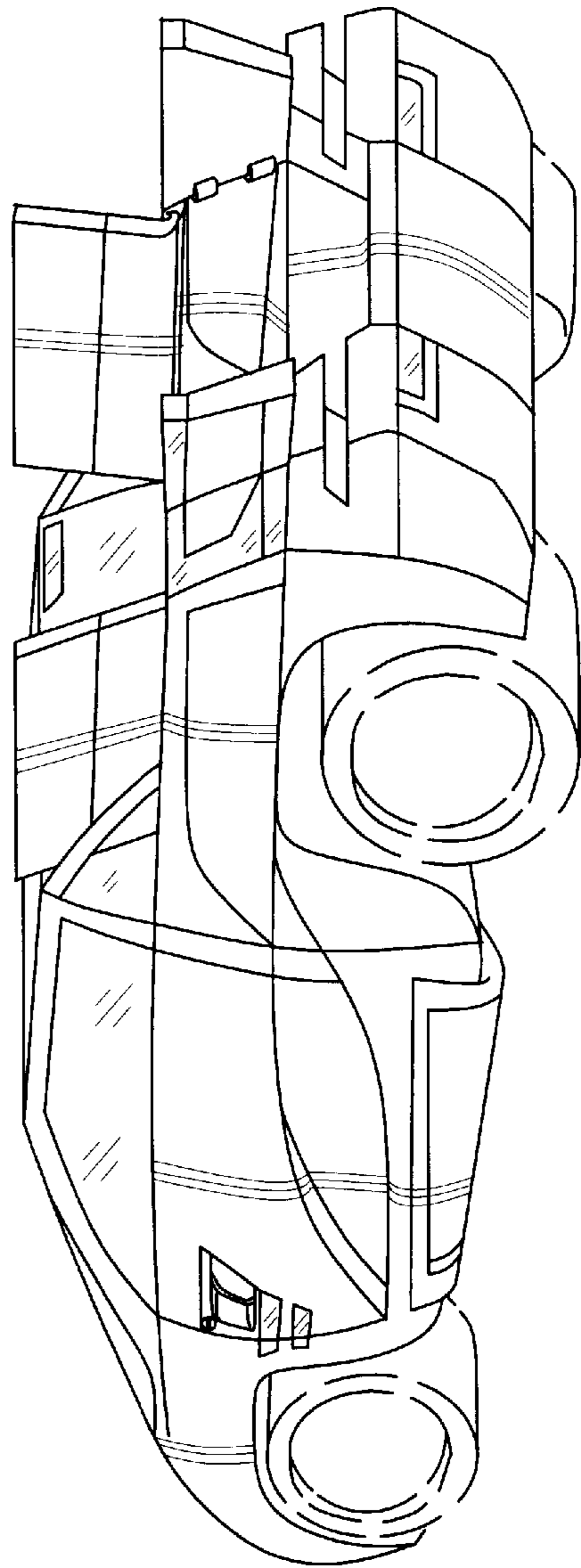

Fig - 8

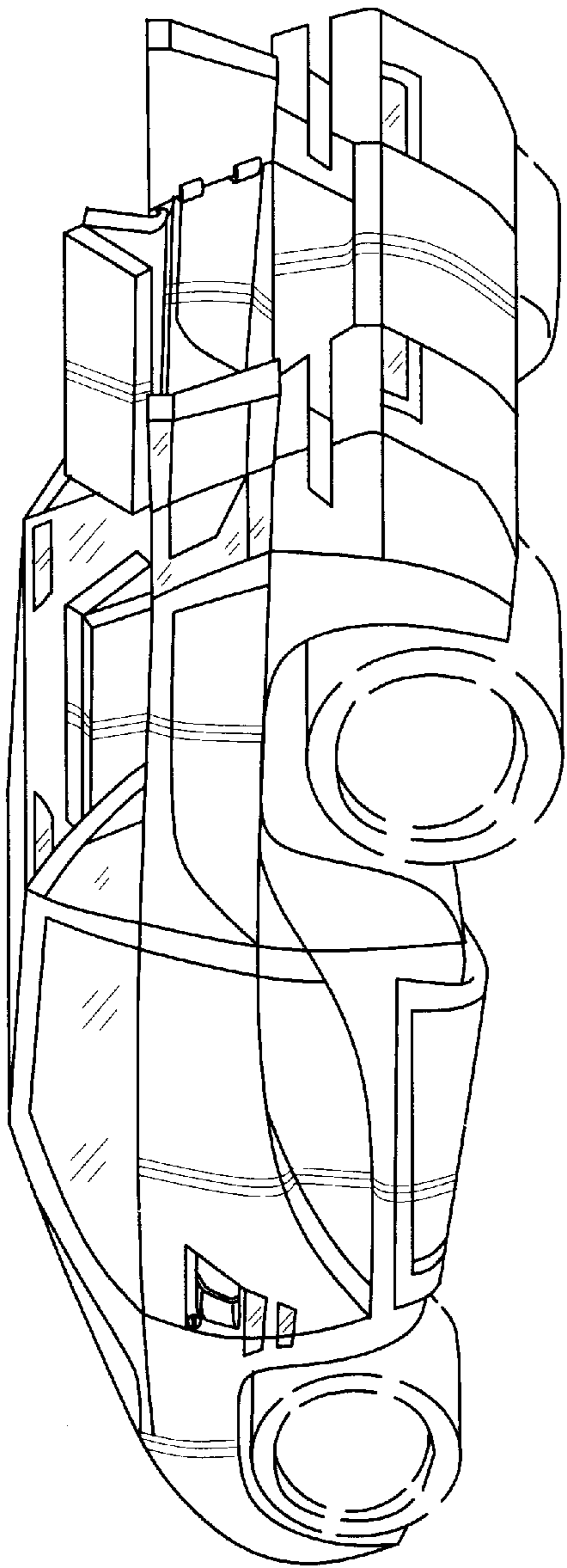

Fig - 9

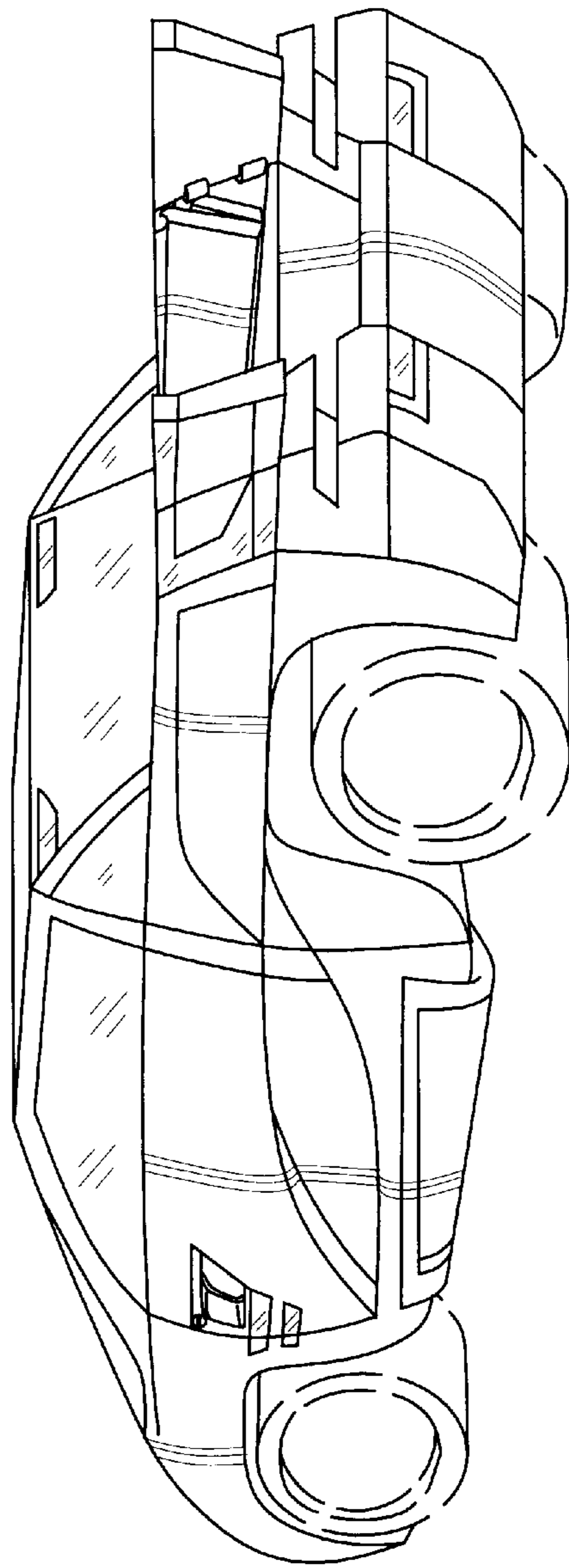

Fig - 10