



US00D463499S

(12) **United States Design Patent**
Marcos

(10) **Patent No.: US D463,499 S**

(45) **Date of Patent: ** Sep. 24, 2002**

(54) **URBAN CLOSET FOR ADVERTISEMENT**

(75) **Inventor: Javier Moreno Marcos, Mexico City (MX)**

(73) **Assignee: Equipamientos Urbanos de Mexico, S.A. de C.V. (MX)**

(**) **Term: 14 Years**

(21) **Appl. No.: 29/143,833**

(22) **Filed: Jun. 20, 2001**

(30) **Foreign Application Priority Data**

Dec. 20, 2000 (MX) 001761

(51) **LOC (7) Cl. 20-03**

(52) **U.S. Cl. D20/10**

(58) **Field of Search D20/10, 16-21, D20/39-99; 40/446-482, 541-585, 605-612**

(56) **References Cited**

U.S. PATENT DOCUMENTS

D279,201 S * 6/1985 Shuman D20/43
D330,919 S * 11/1992 Von Canal D20/10

5,615,503 A * 4/1997 Current 40/601
D392,686 S * 3/1998 Sarkisian et al. D20/41
D396,065 S * 7/1998 Johnson et al. D20/41
5,927,676 A * 7/1999 Lefton 248/472

* cited by examiner

Primary Examiner—Caron D. Veynar

(74) *Attorney, Agent, or Firm*—Fulbright & Jaworski LLP

(57) **CLAIM**

The ornamental design for an urban closet for advertisement, as shown and described.

DESCRIPTION

FIG. 1 is a perspective view of an urban closet for advertisement with one door open showing my new design; FIG. 2 is a side elevation view thereof, the opposite side view is mirror image thereof; FIG. 3 is a front perspective view thereof; FIG. 4 is a rear perspective view thereof; FIG. 5 is a top plan view thereof; and, FIG. 6 is a front elevation view with the door closed. The broken lines shown on FIGS. 1-6 are for illustrative purposes only and form no part of the claimed design.

1 Claim, 6 Drawing Sheets

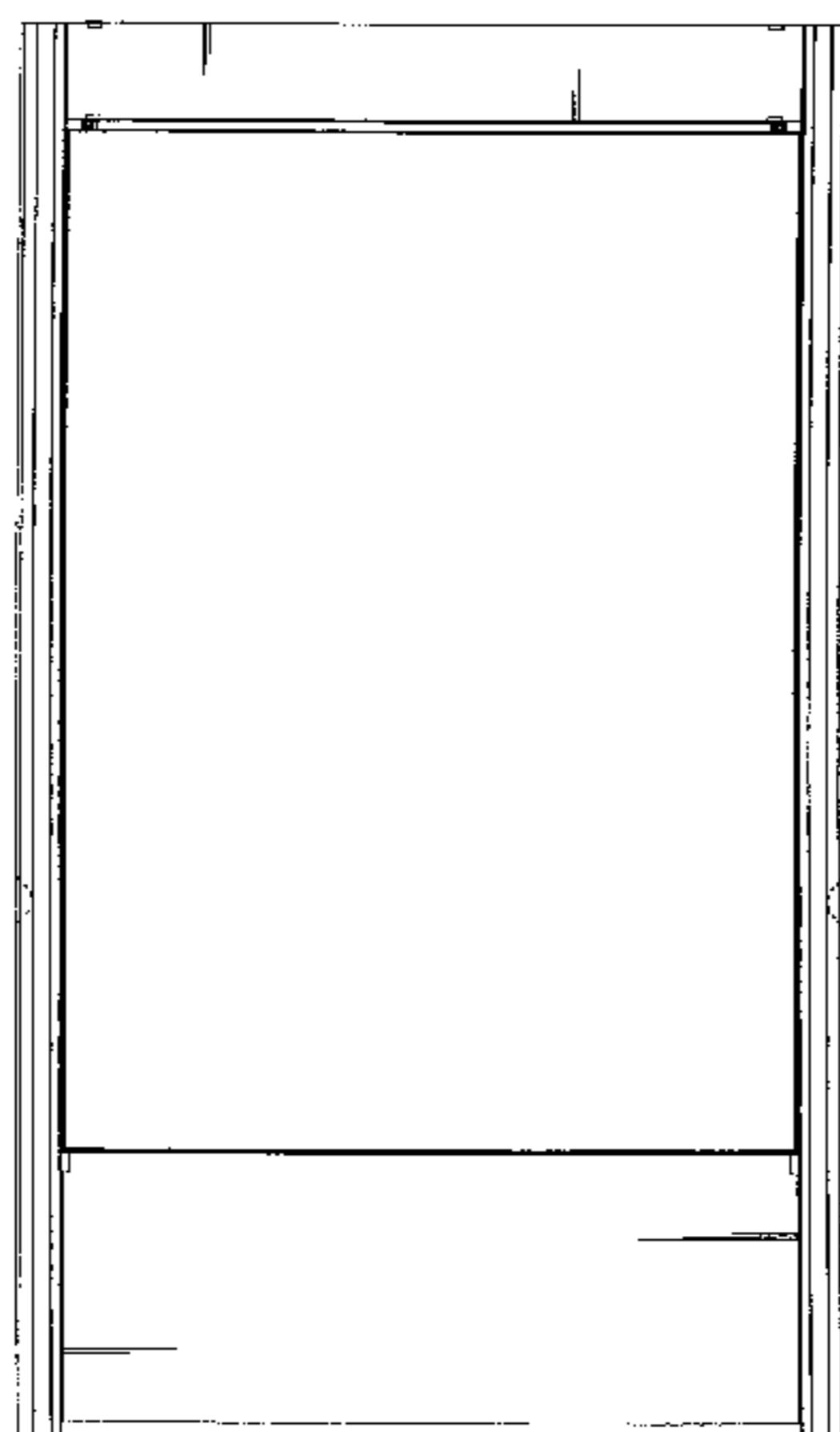
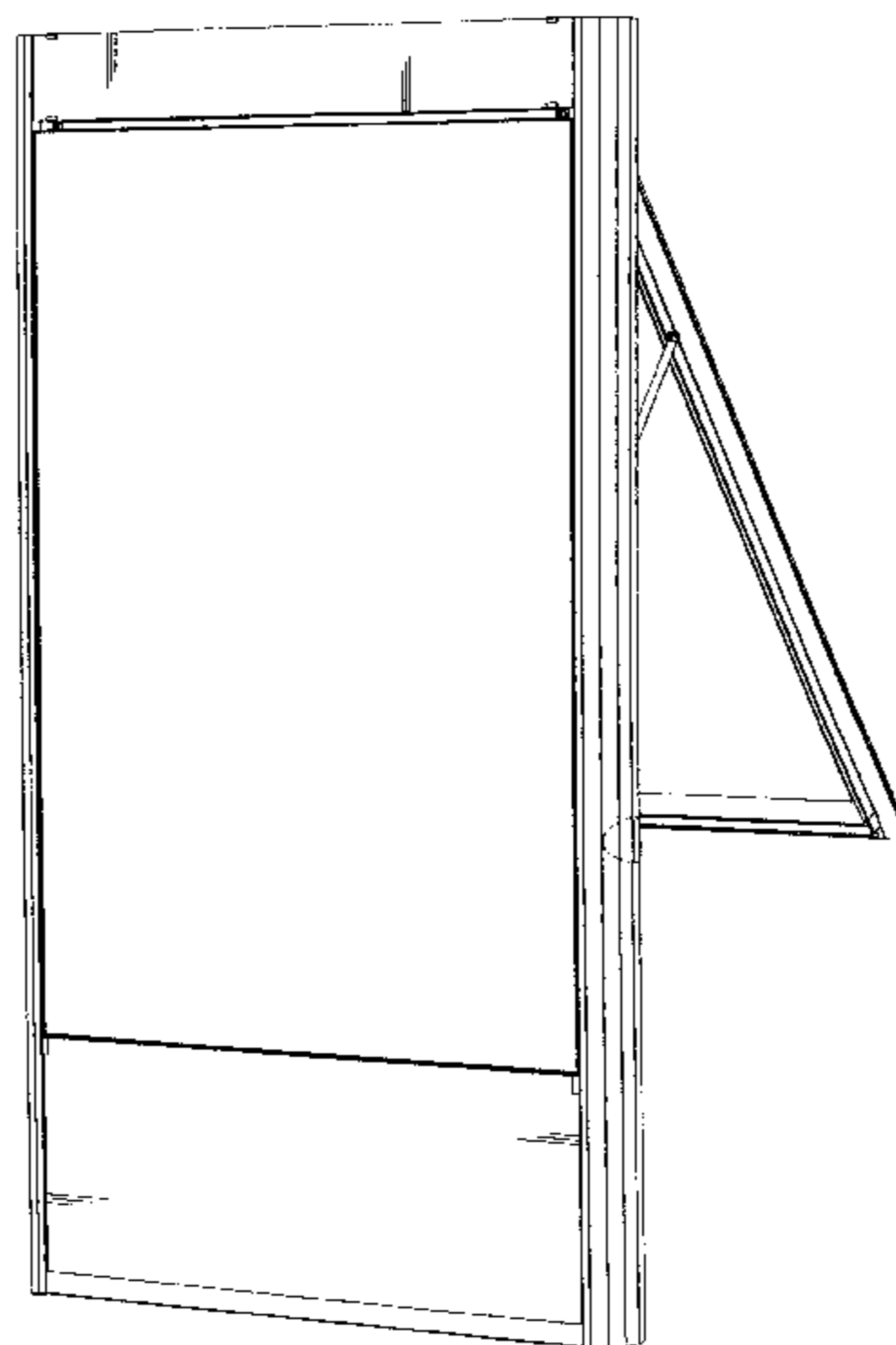

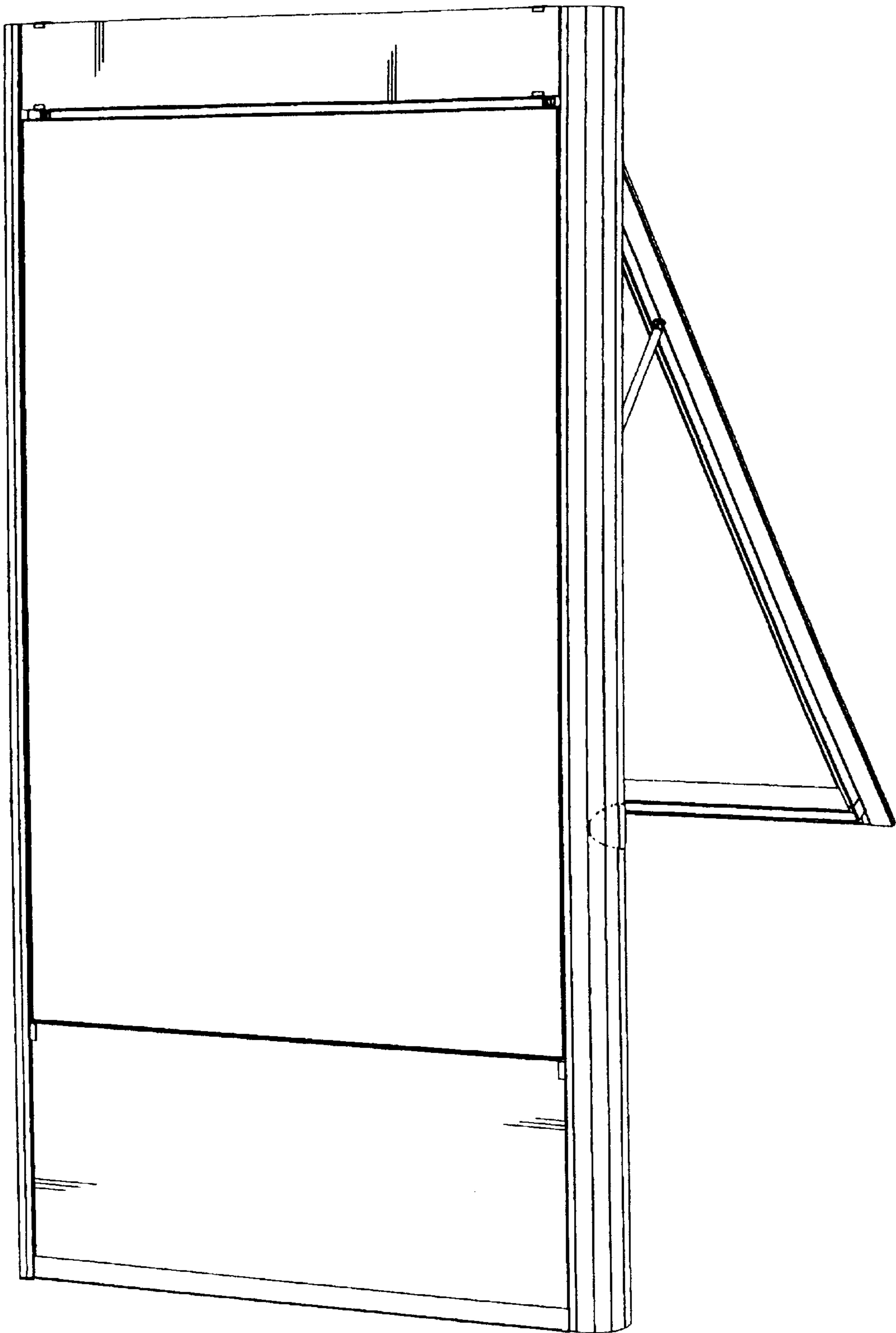

Fig. 1

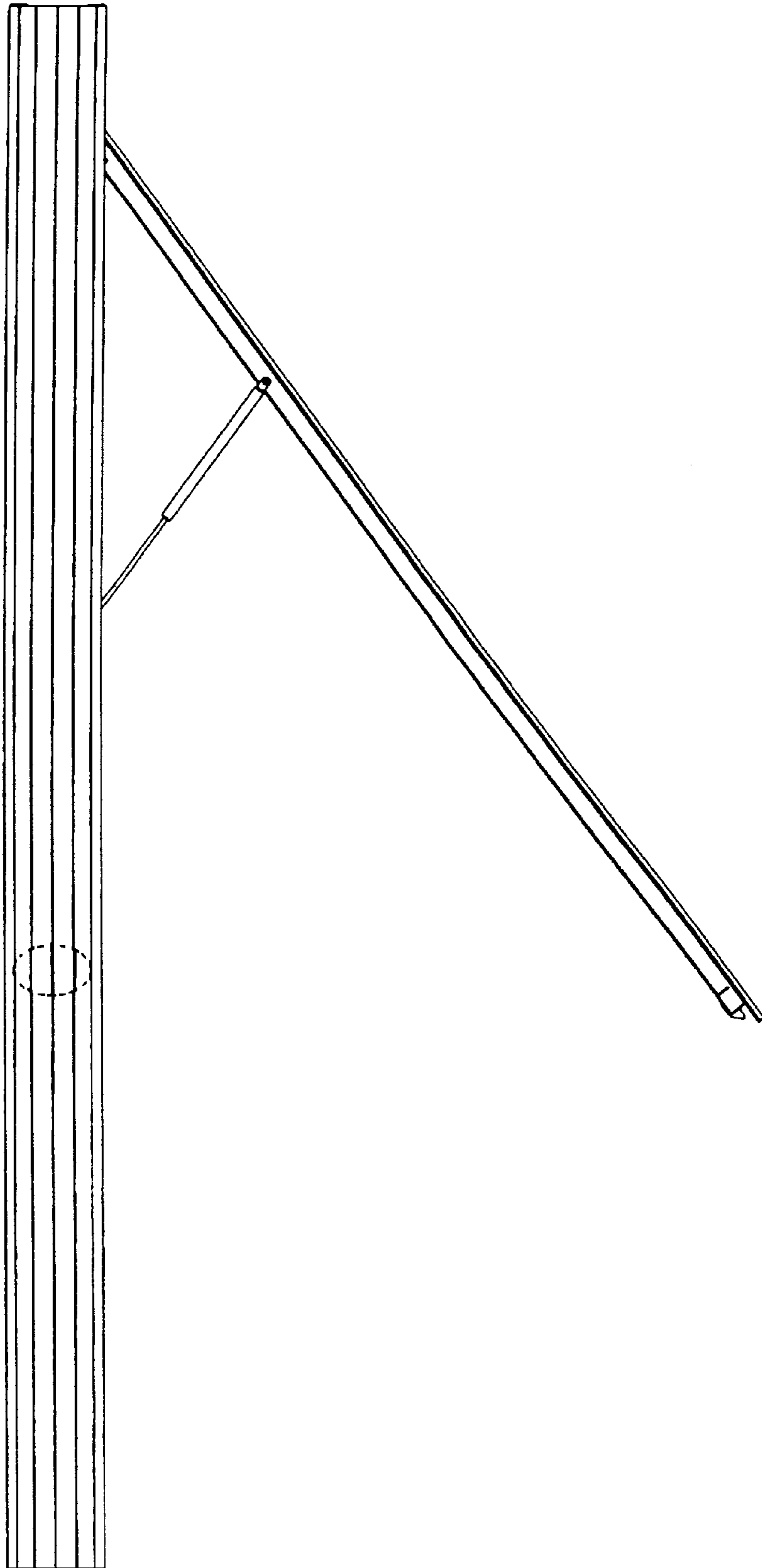

Fig. 2

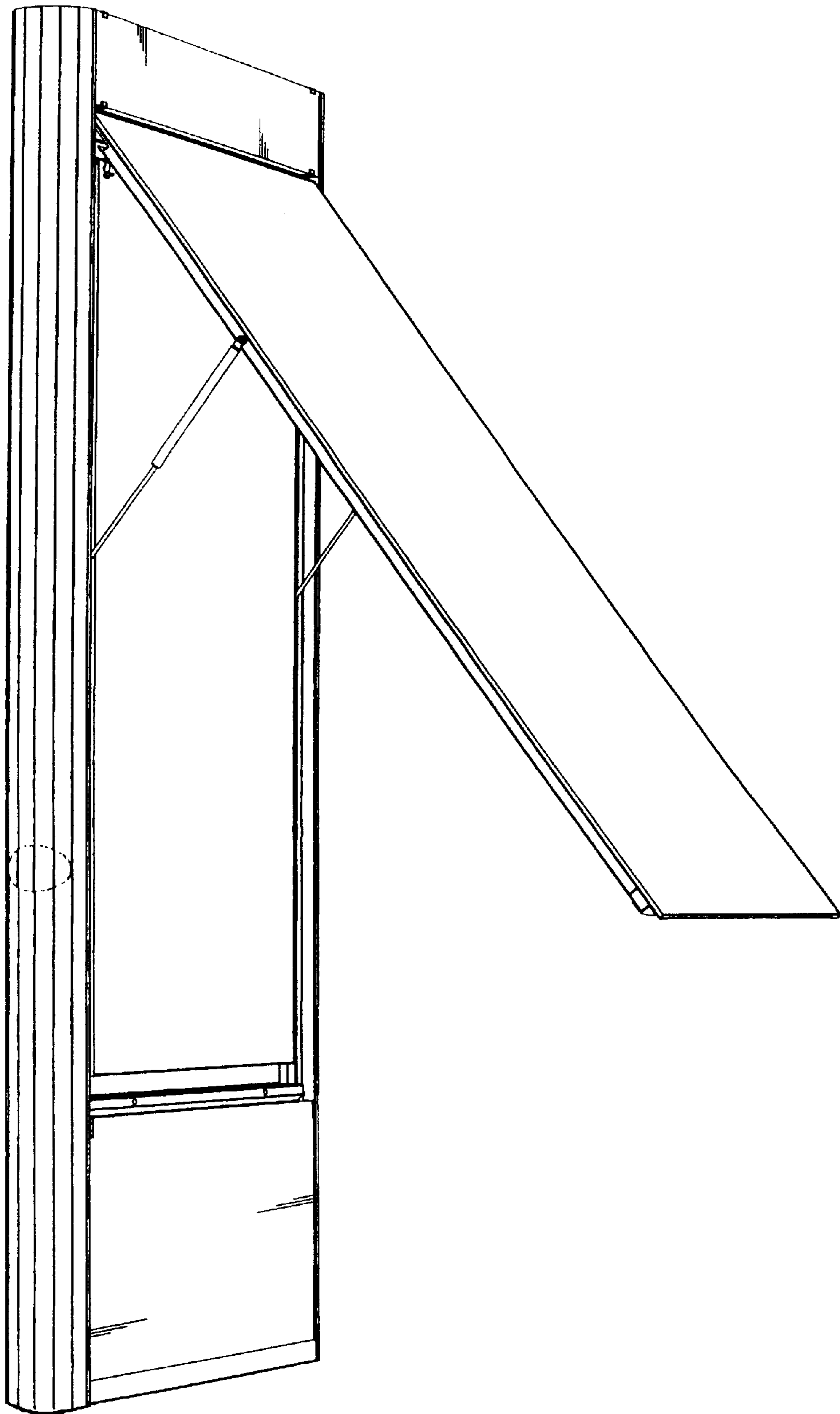

Fig. 3

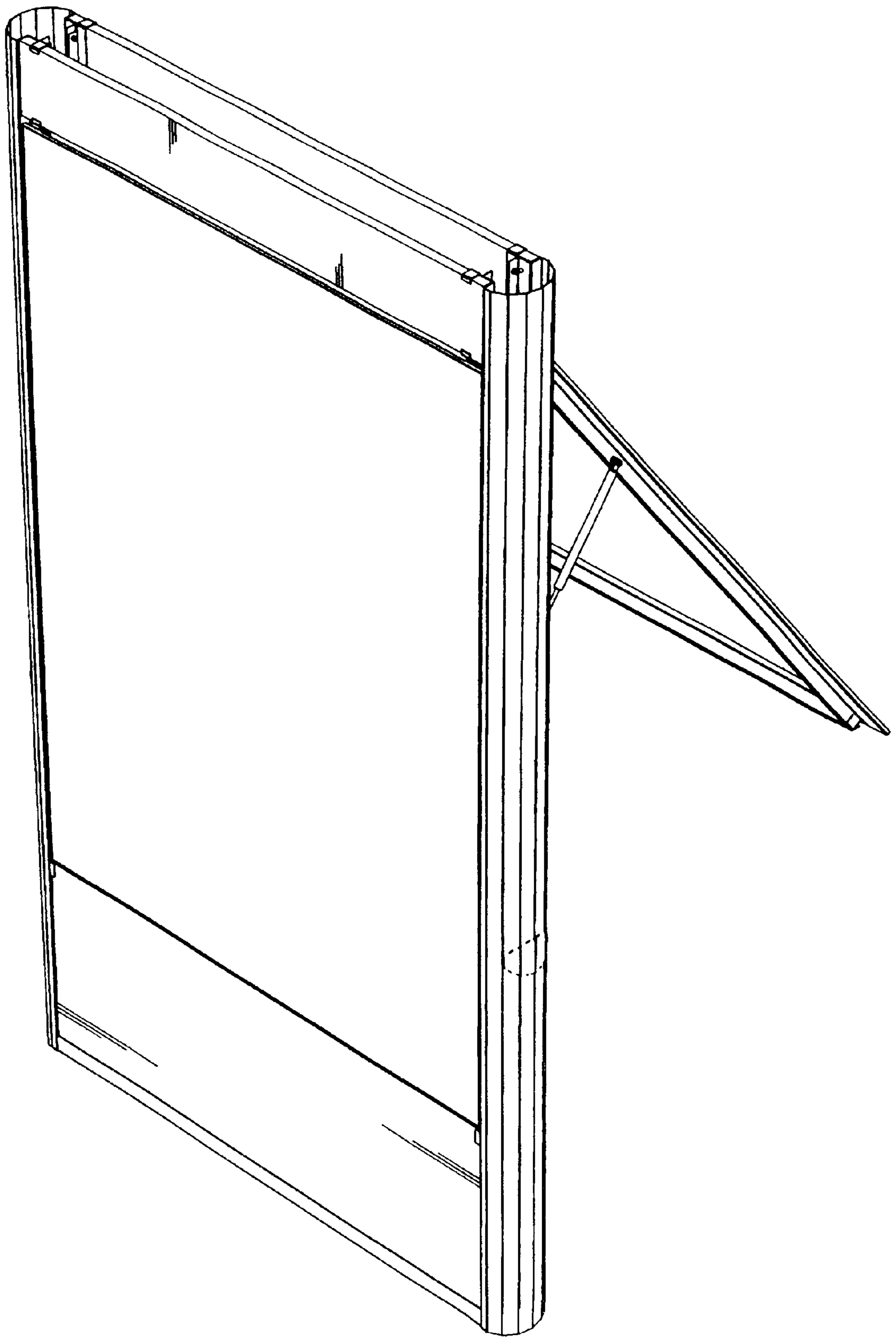

Fig. 4

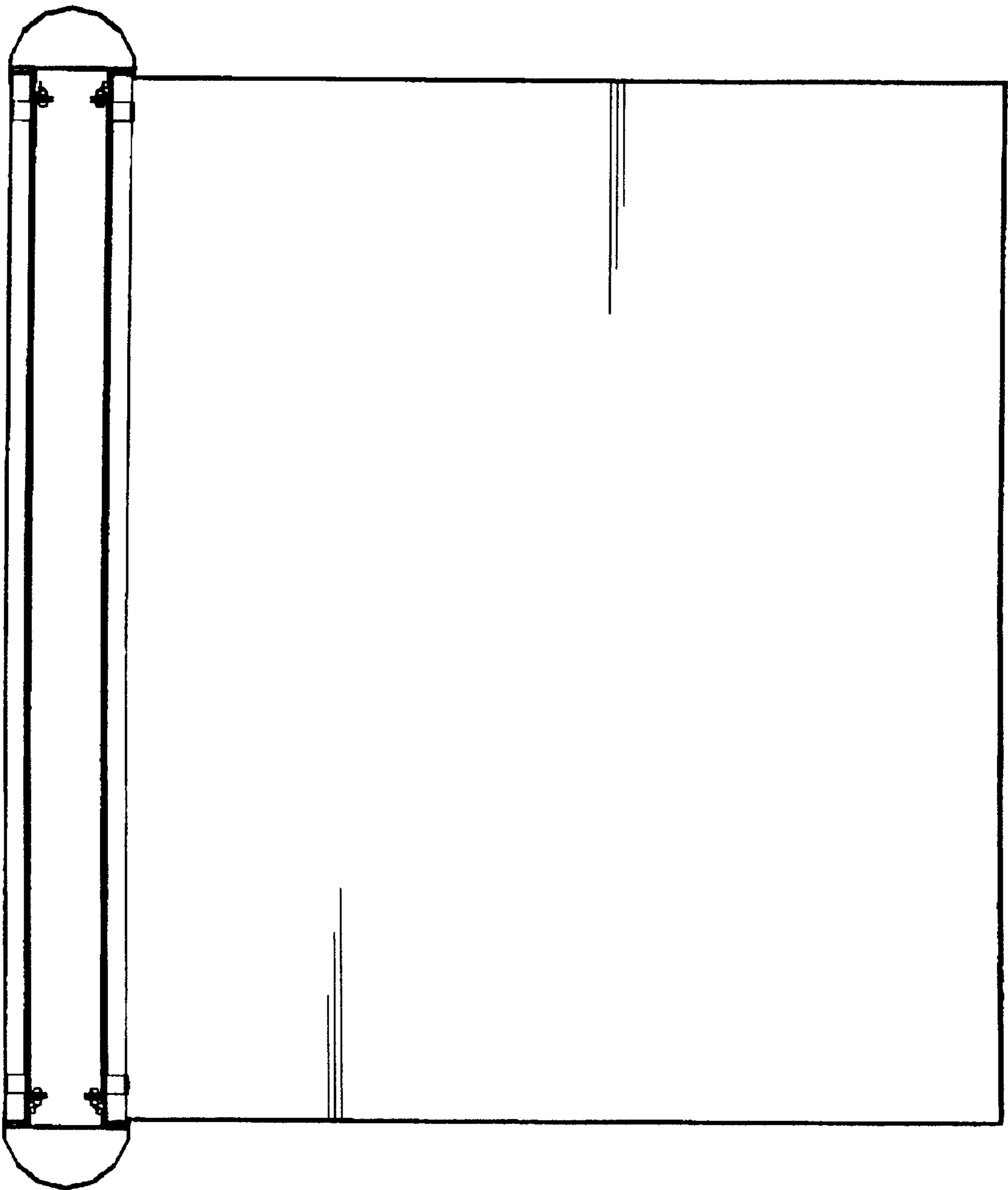

Fig. 5

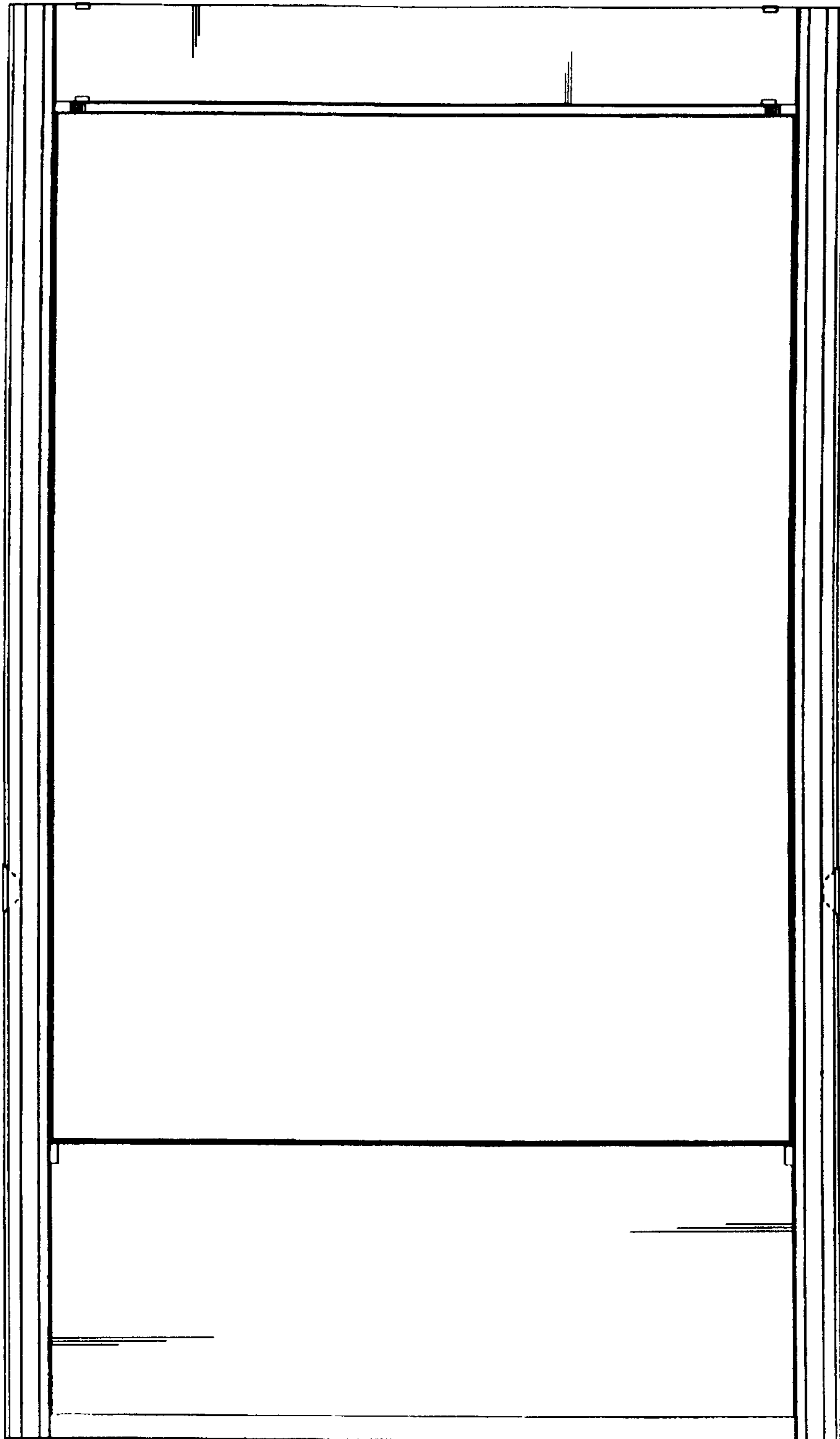

Fig. 6