



US00D463365S

(12) **United States Design Patent**
Sakai et al.

(10) **Patent No.:** **US D463,365 S**

(45) **Date of Patent:** **** Sep. 24, 2002**

(54) **MAGNETIC CORE FOR TRANSFORMER FOR ELECTRONIC DEVICE**

5,434,493 A * 7/1995 Woody et al. 320/2
5,684,445 A * 11/1997 Kobayashi et al. 336/83
5,748,064 A * 5/1998 Smeenge et al. 336/83
6,138,344 A * 10/2000 Roessler et al. 29/606

(75) Inventors: **Shinichi Sakai**, Nara (JP); **Kazuho Sakamoto**, Kyoto (JP)

OTHER PUBLICATIONS

(73) Assignee: **Matsushita Electric Industrial Co., Ltd.**, Osaka (JP)

TDK catalog pages.

(**) Term: **14 Years**

* cited by examiner

(21) Appl. No.: **29/123,739**

Primary Examiner—Joel Sincavage

(22) Filed: **May 24, 2000**

(74) *Attorney, Agent, or Firm*—Christensen O'Connor Johnson Kindness PLLC

(30) **Foreign Application Priority Data**

(57) **CLAIM**

Nov. 29, 1999 (JP) 11-32936

The ornamental design for a magnetic core for transformer for electronic device, as shown and described.

(51) **LOC (7) Cl.** **13-02**

DESCRIPTION

(52) **U.S. Cl.** **D13/118**

(58) **Field of Search** D13/118; 336/83, 336/210, 219, 233; 29/606

FIG. 1 is a perspective view of the top, front and right side of a magnetic core for transformer for electronic device showing our new design;

(56) **References Cited**

FIG. 2 is a top plan view thereof;

U.S. PATENT DOCUMENTS

D264,959 S * 6/1982 Ota et al. D13/118
4,352,080 A * 9/1982 Mitsui et al. 336/83
4,424,504 A * 1/1984 Mitsui et al. 336/83
D280,810 S * 10/1985 Mitsui D13/118
5,175,525 A * 12/1992 Smith 336/83

FIG. 3 is a front view thereof;

FIG. 4 is a left side view thereof;

FIG. 5 is a right side view thereof;

FIG. 6 is a rear view thereof; and,

FIG. 7 is a bottom view thereof.

1 Claim, 2 Drawing Sheets

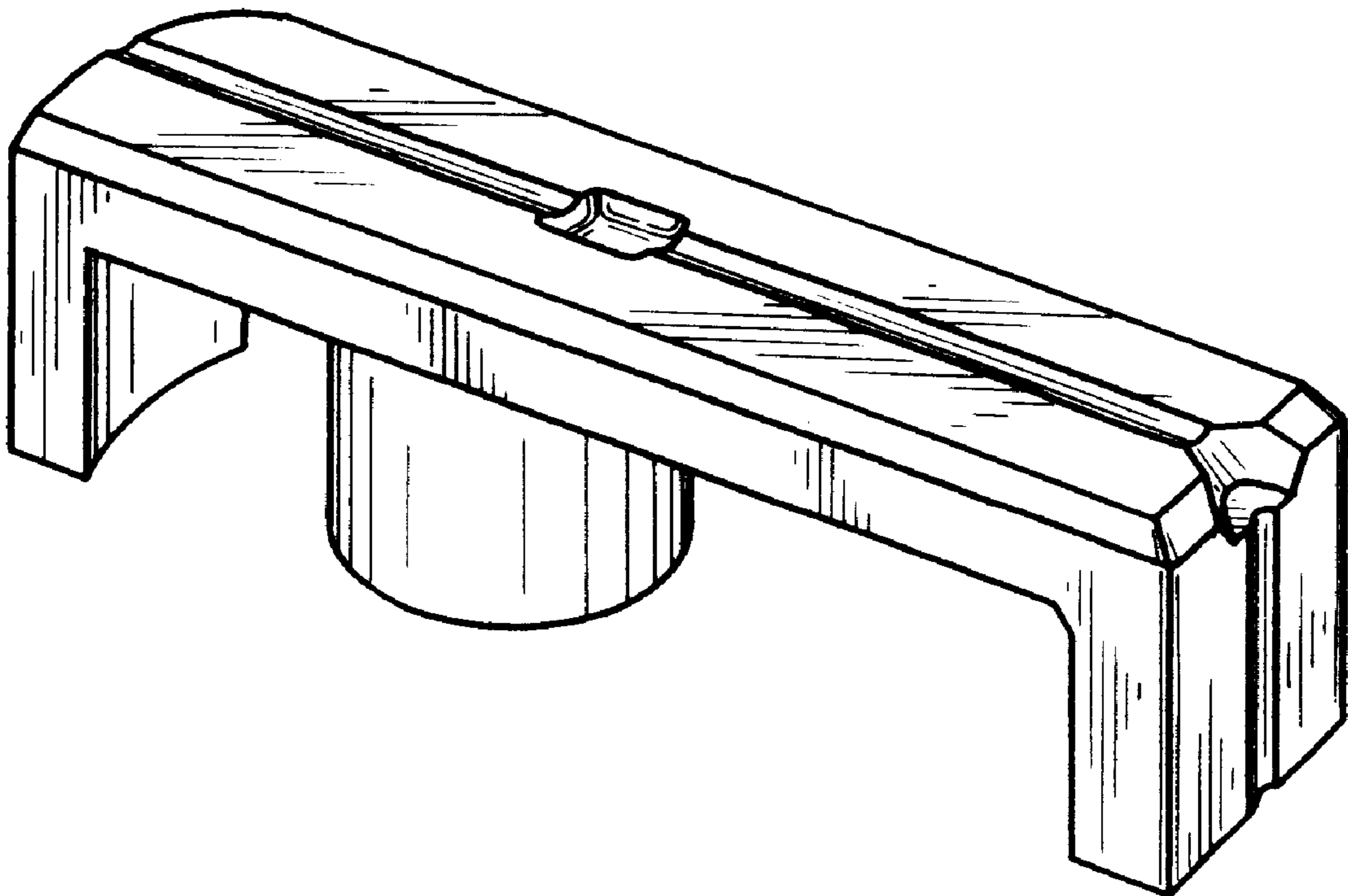

FIG. 1

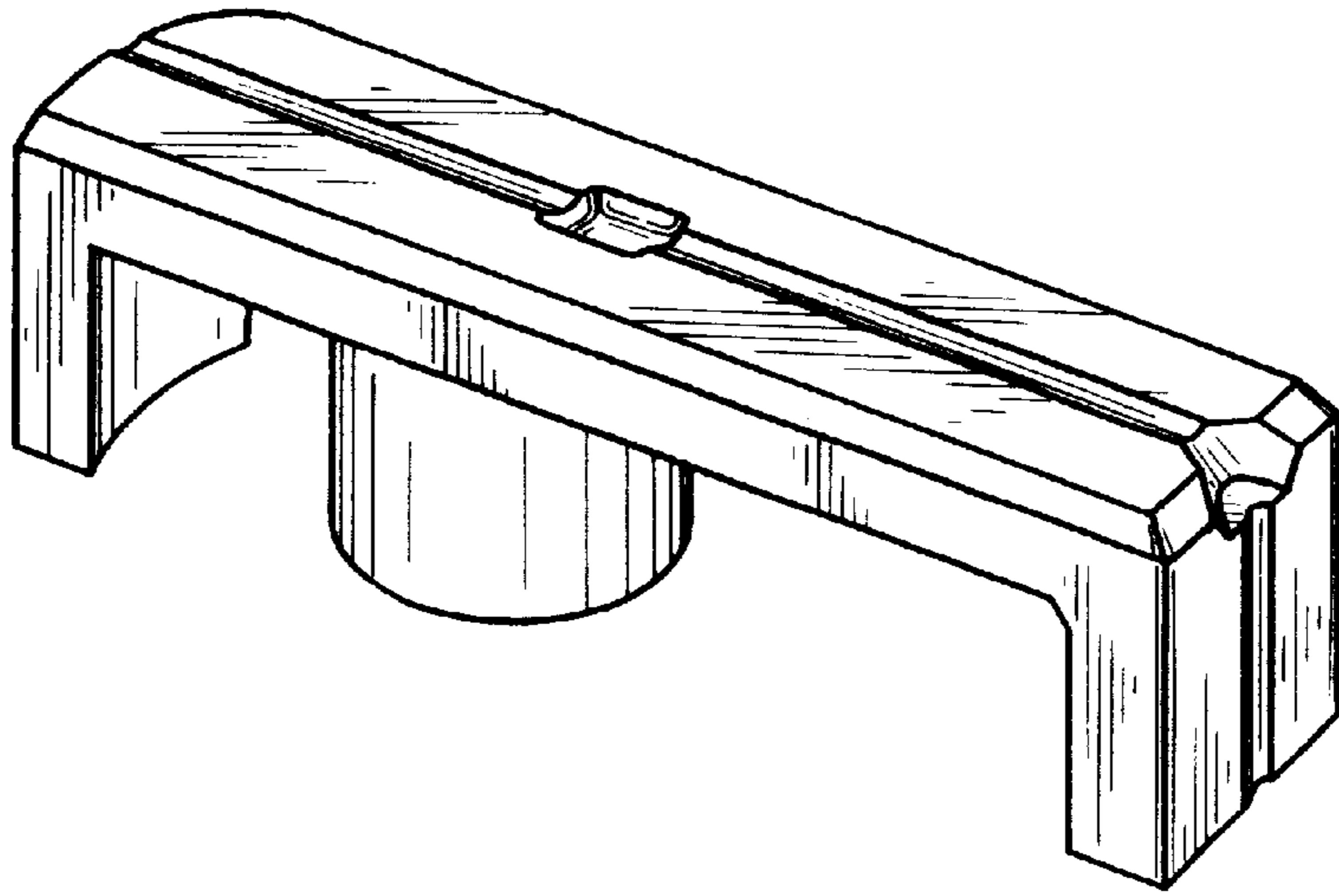

FIG. 2

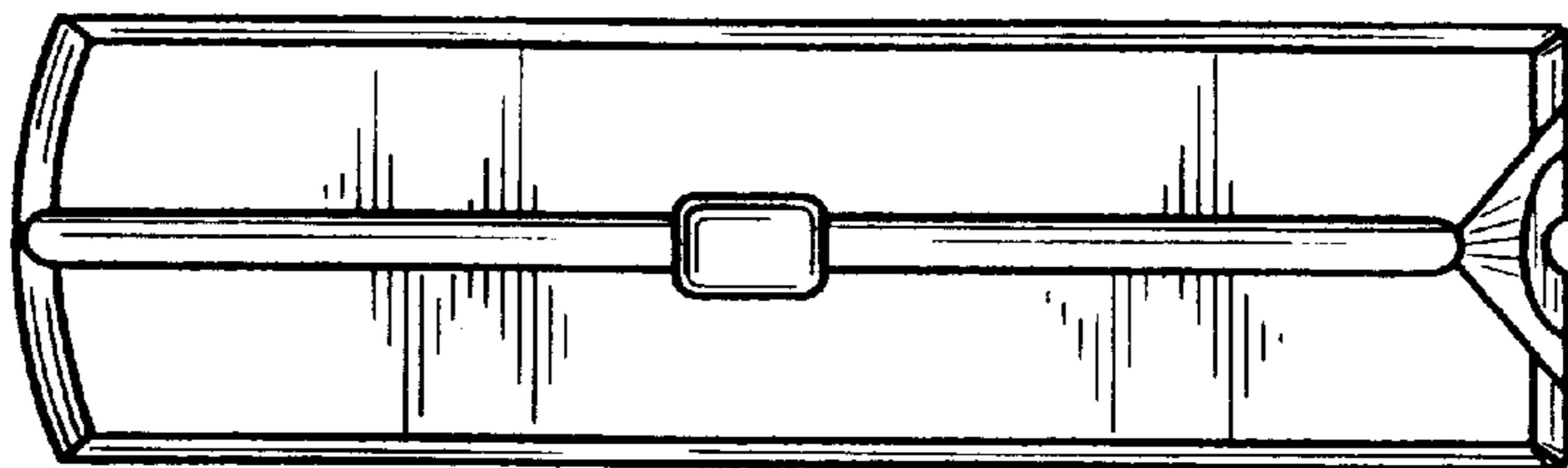

FIG. 3

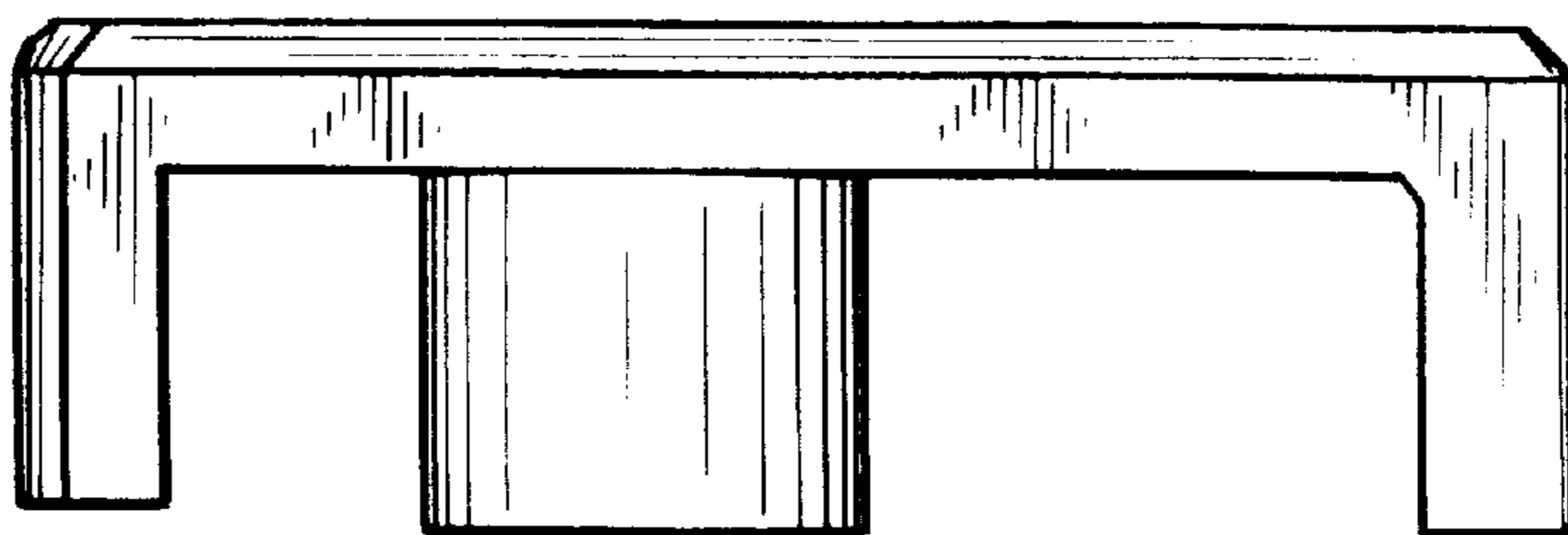

FIG. 4

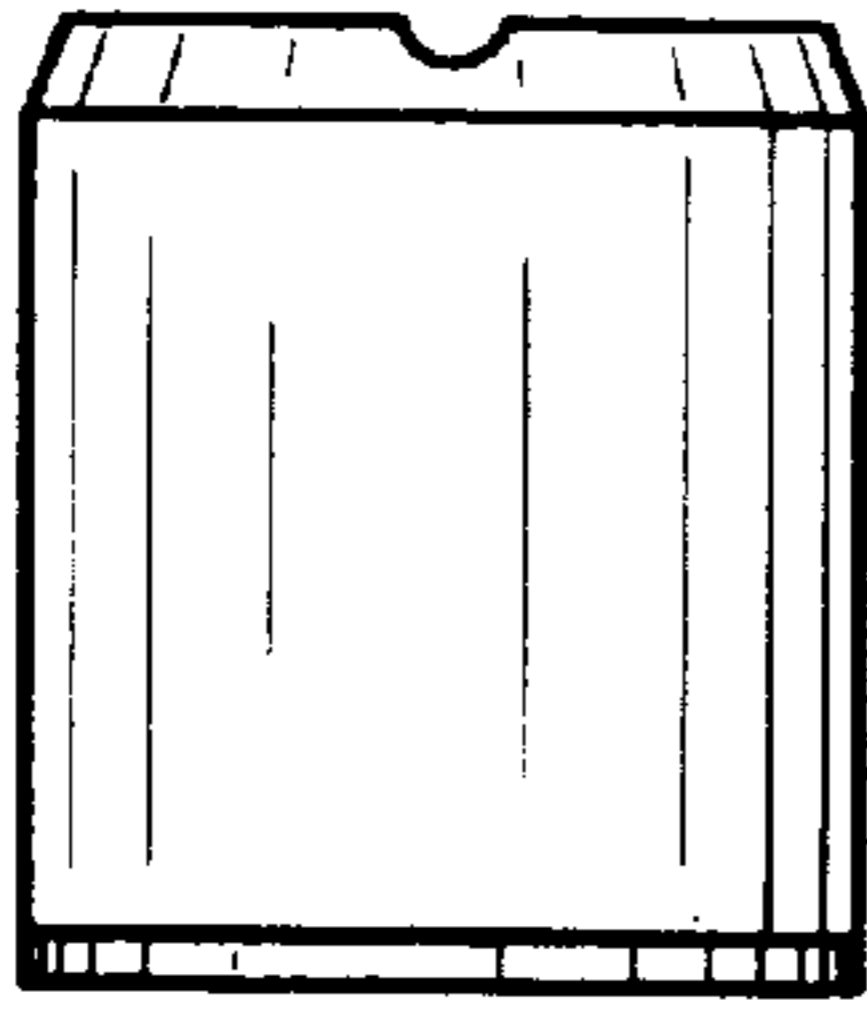

FIG. 5

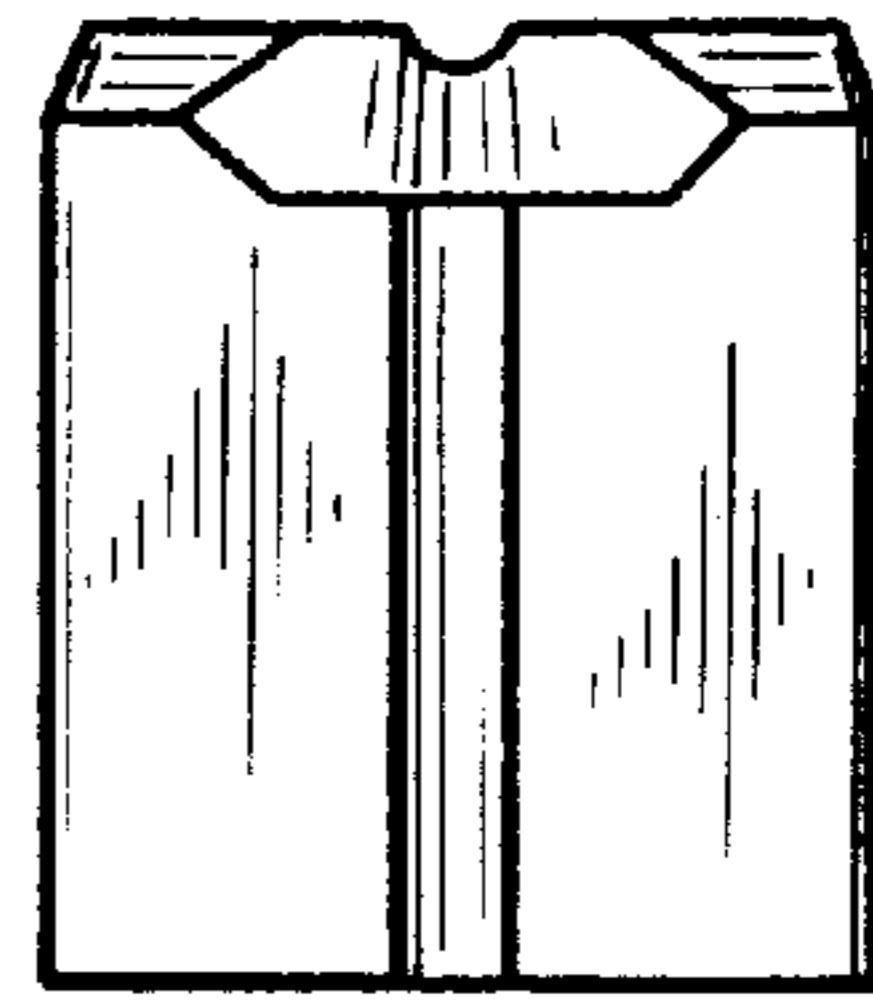

FIG. 6

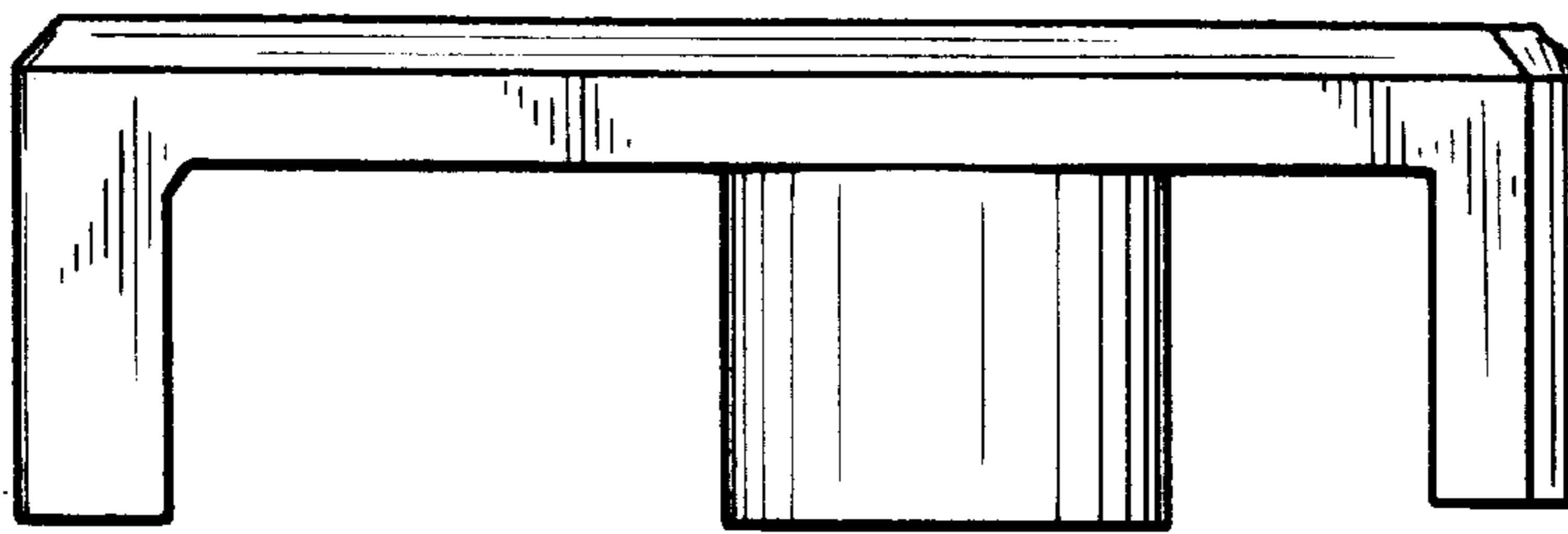

FIG. 7

