



US00D463358S

(12) **United States Design Patent**
Thomas

(10) **Patent No.:** **US D463,358 S**

(45) **Date of Patent:** **** Sep. 24, 2002**

(54) **UTILITY RACK FOR A PICKUP TRUCK**

(74) *Attorney, Agent, or Firm*—Dennis H. Lambert

(76) **Inventor:** **James L. Thomas**, 459 Charter Oak Dr., Newport News, VA (US) 23608

(57) **CLAIM**

(**) **Term:** **14 Years**

I claim the ornamental design for a utility rack for a pickup truck, as shown and described.

(21) **Appl. No.:** **29/124,236**

DESCRIPTION

(22) **Filed:** **Jun. 2, 2000**

(51) **LOC (7) Cl.** **12-16**

(52) **U.S. Cl.** **D12/406**

(58) **Field of Search** D12/406, 412–414.1; 296/3, 37.1; 224/402–405; 211/41, 162, 182, 175–176, 205–206; 52/731.7, 731.6, 735.1, 737.6

FIG. 1 is a side view in elevation of my design for a utility rack for a pickup truck, showing a truck in dashed lines for purpose of environment;

FIG. 2 is a front view in elevation of my design, showing a truck in dashed lines for purpose of environment;

FIG. 3 is a rear view in elevation of my design, showing a truck in dashed lines for purpose of environment;

FIG. 4 is an enlarged top plan view of the design;

FIG. 5 is an enlarged left side view of the design, the right side view being a mirror image thereof;

FIG. 6 is an enlarged rear view in elevation of the design;

FIG. 7 is an enlarged front view in elevation of the design;

FIG. 8 is a section view, taken along line 8—8 in FIG. 5, showing the rounded tubular shape of the rack;

FIG. 9 is an enlarged view in side elevation of the area circled at 9 in FIG. 5;

FIG. 10 is a top plan view of FIG. 9.

FIG. 11 is a rear view in elevation of FIG. 9.

FIG. 12 is an enlarged view in side elevation of the area circled at 12 in FIG. 5.

FIG. 13 is a top plan view of FIG. 12; and,

FIG. 14 is a rear view in elevation of the design of FIG. 12.

The broken line showing of environment is for illustrative purposes only and forms no part of the claimed design.

(56) **References Cited**

U.S. PATENT DOCUMENTS

D220,688 S	*	5/1971	Zulim	D12/406
D236,973 S	*	9/1975	Burton	D12/406
D244,266 S	*	5/1977	Hinch	D12/406
4,057,281 A	*	11/1977	Garrett	296/3
4,278,175 A	*	7/1981	Jackson	211/41
D305,111 S	*	12/1989	Zagner	D12/406
D360,614 S	*	7/1995	Alcocer	D12/412
D367,843 S	*	3/1996	Tayar	D12/412
D434,364 S	*	11/2000	Bauer et al.	D12/412
D436,915 S	*	1/2001	Burger	D12/406
D444,446 S	*	7/2001	Carter	D12/406

* cited by examiner

Primary Examiner—Stacia Cadmus

1 Claim, 4 Drawing Sheets

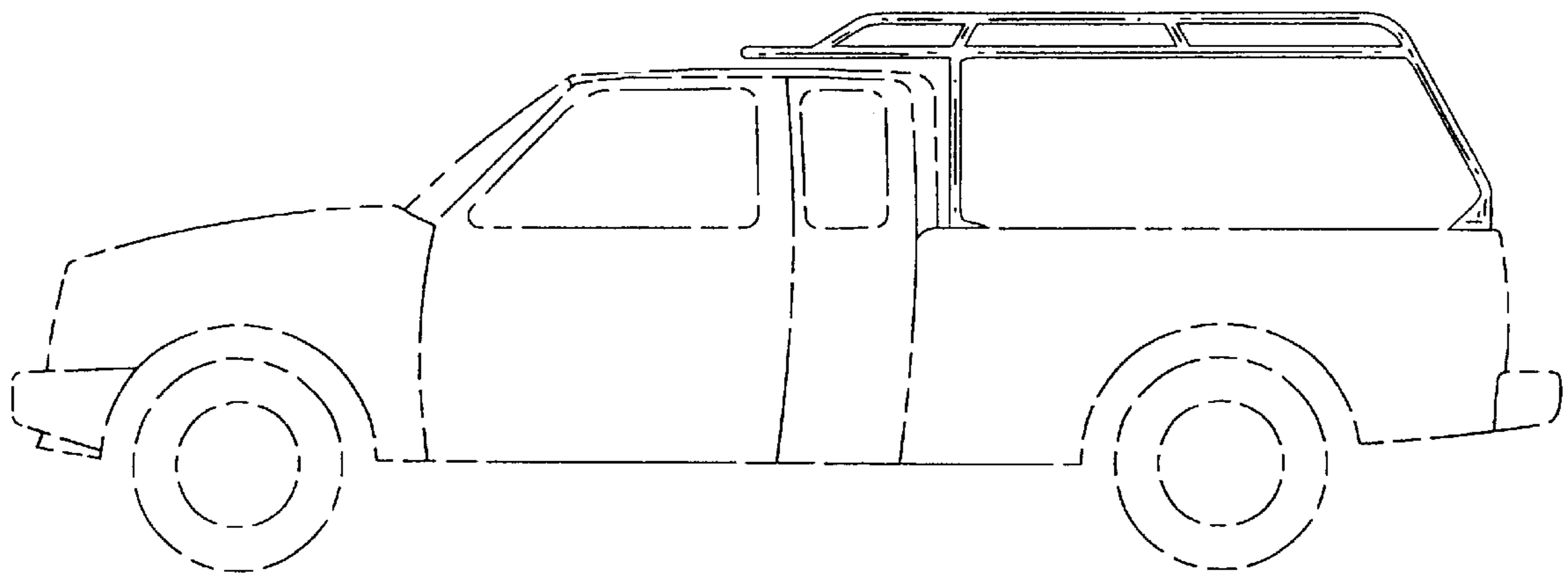

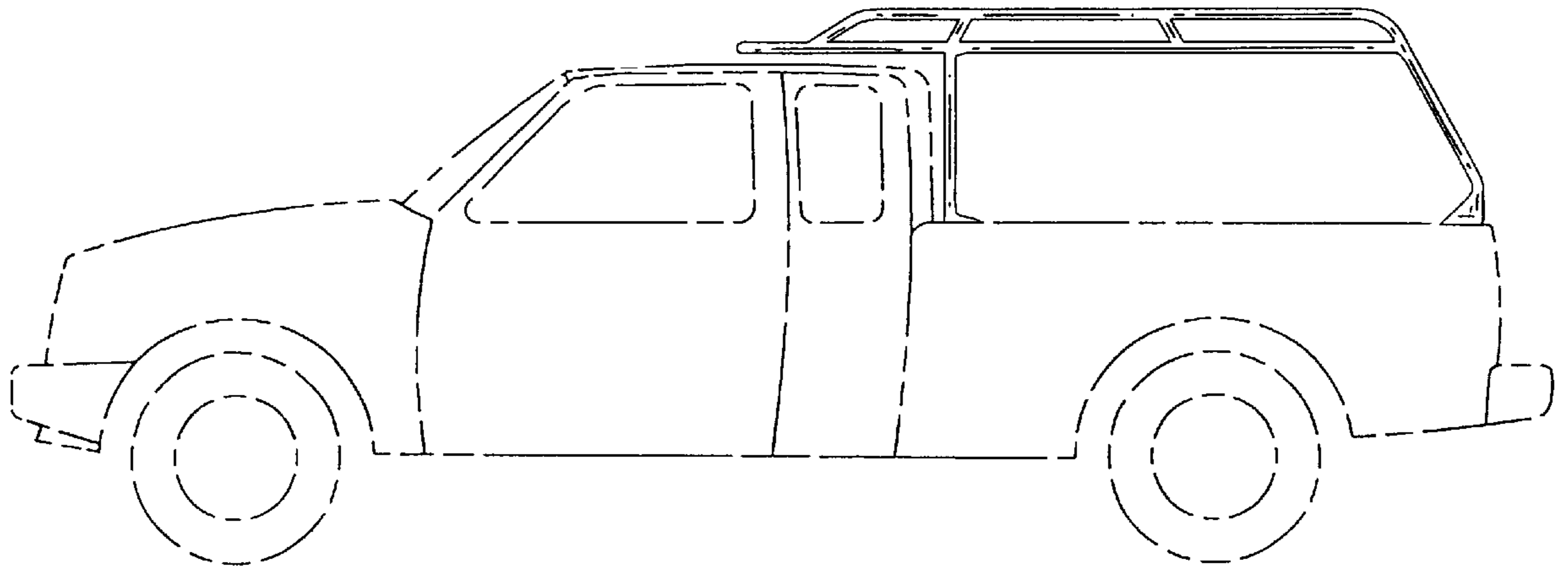

FIG. 1

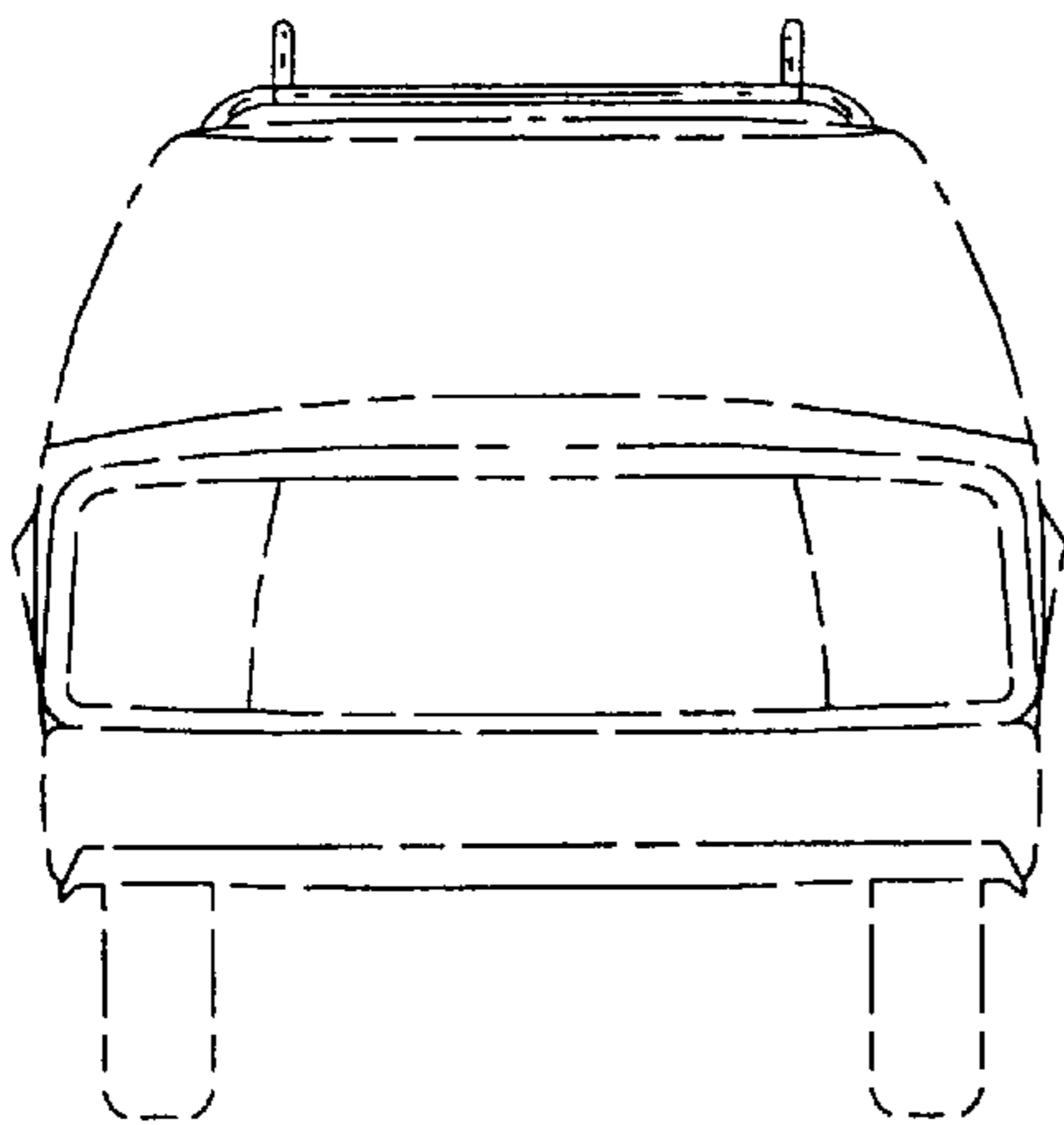

FIG. 2

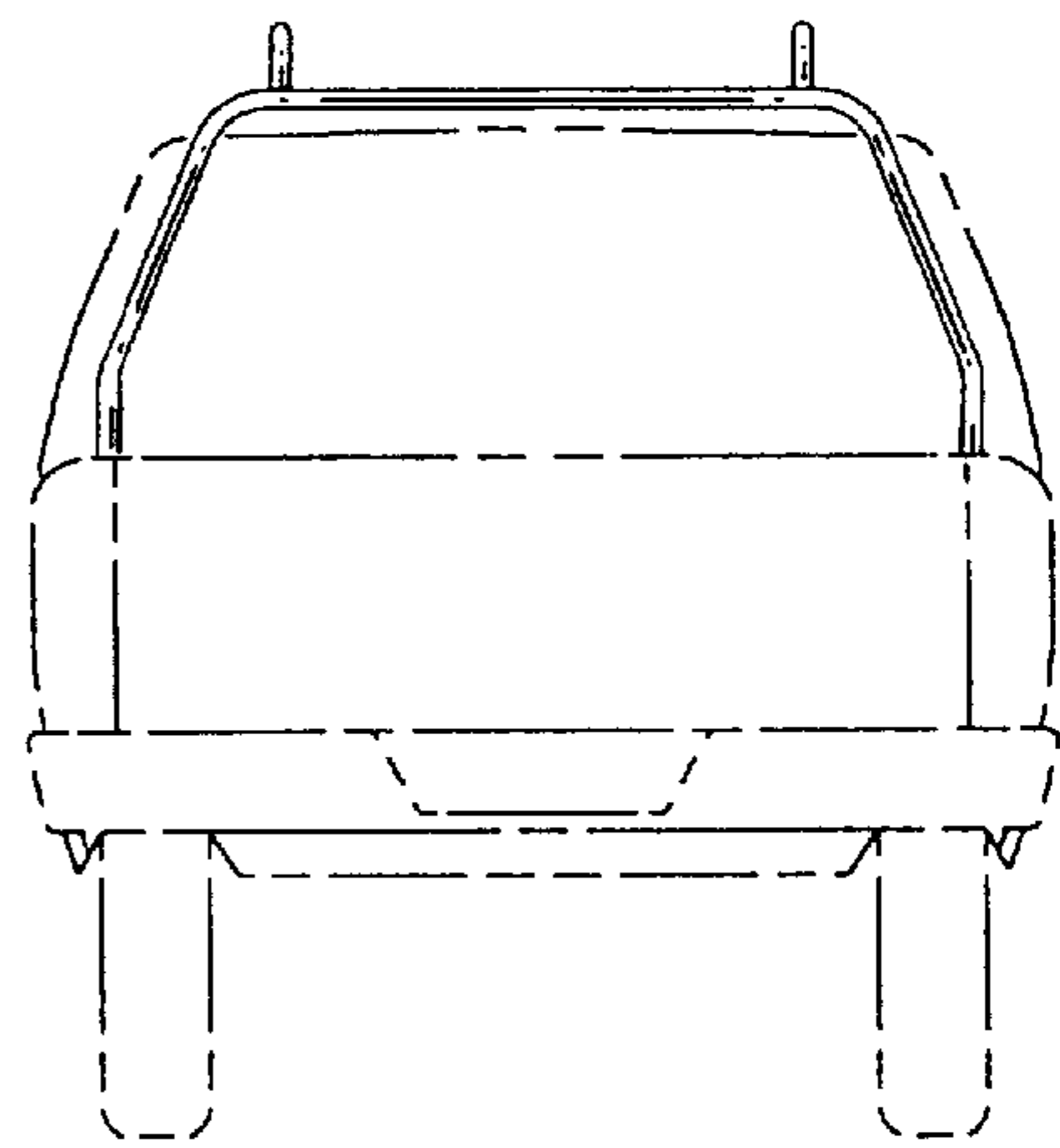

FIG. 3

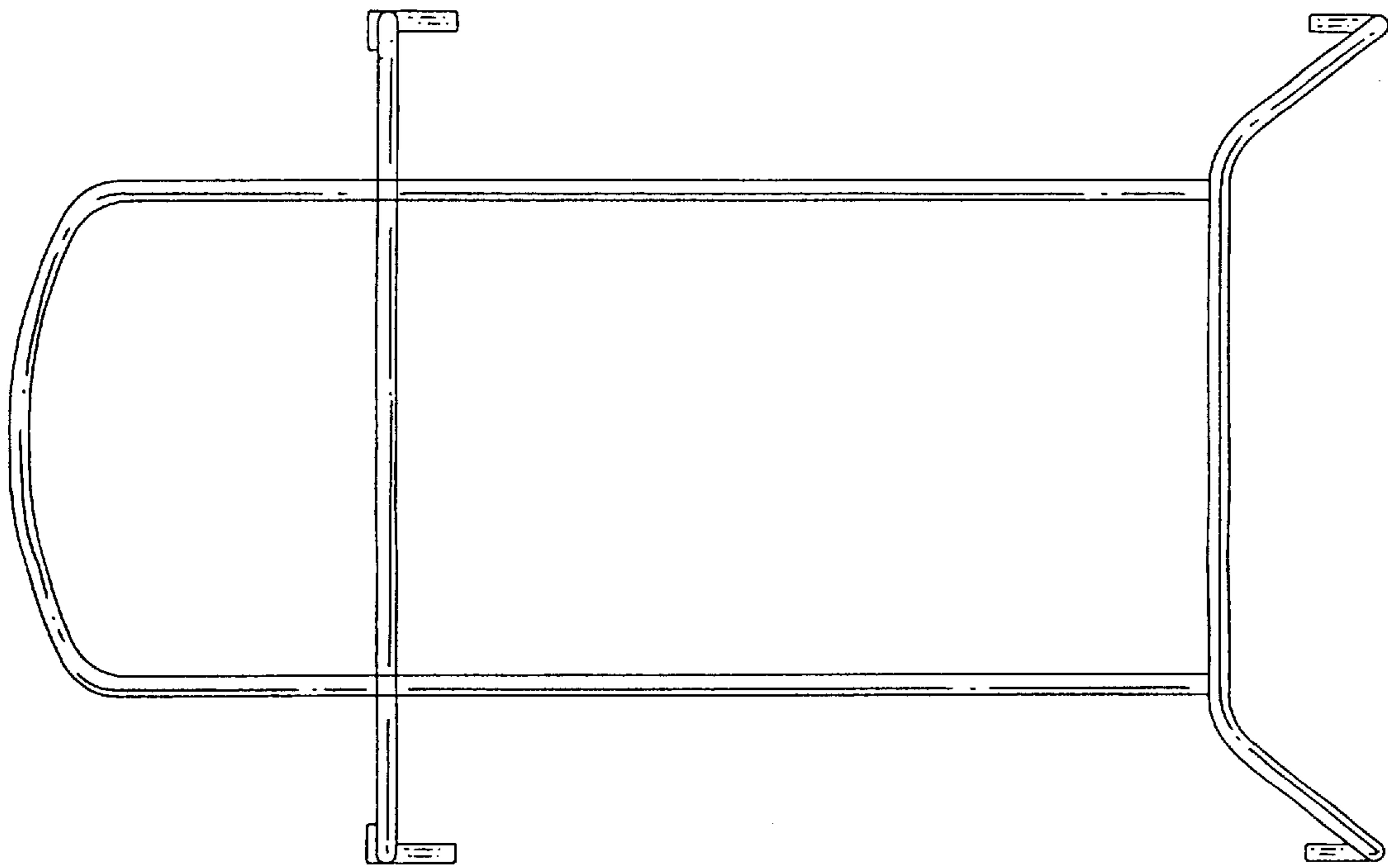

FIG. 4

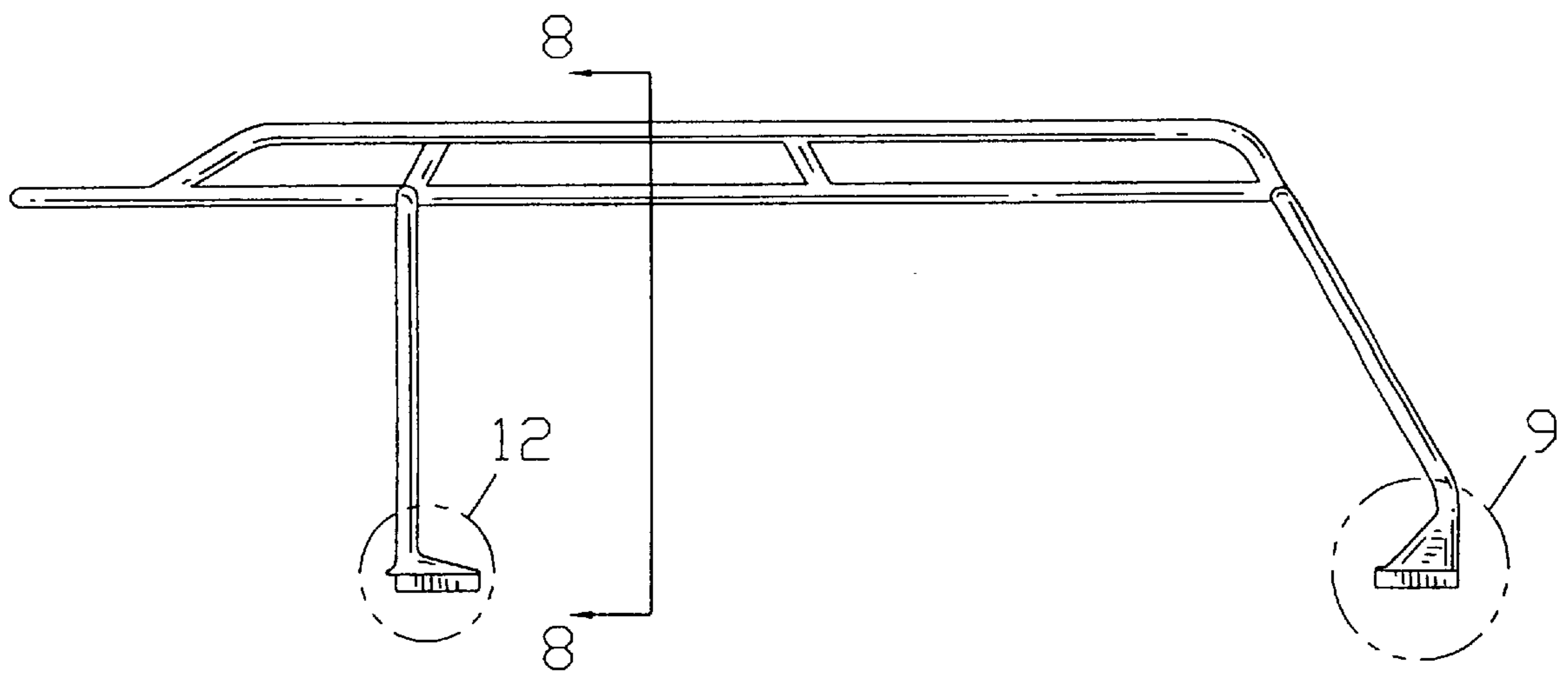

FIG. 5

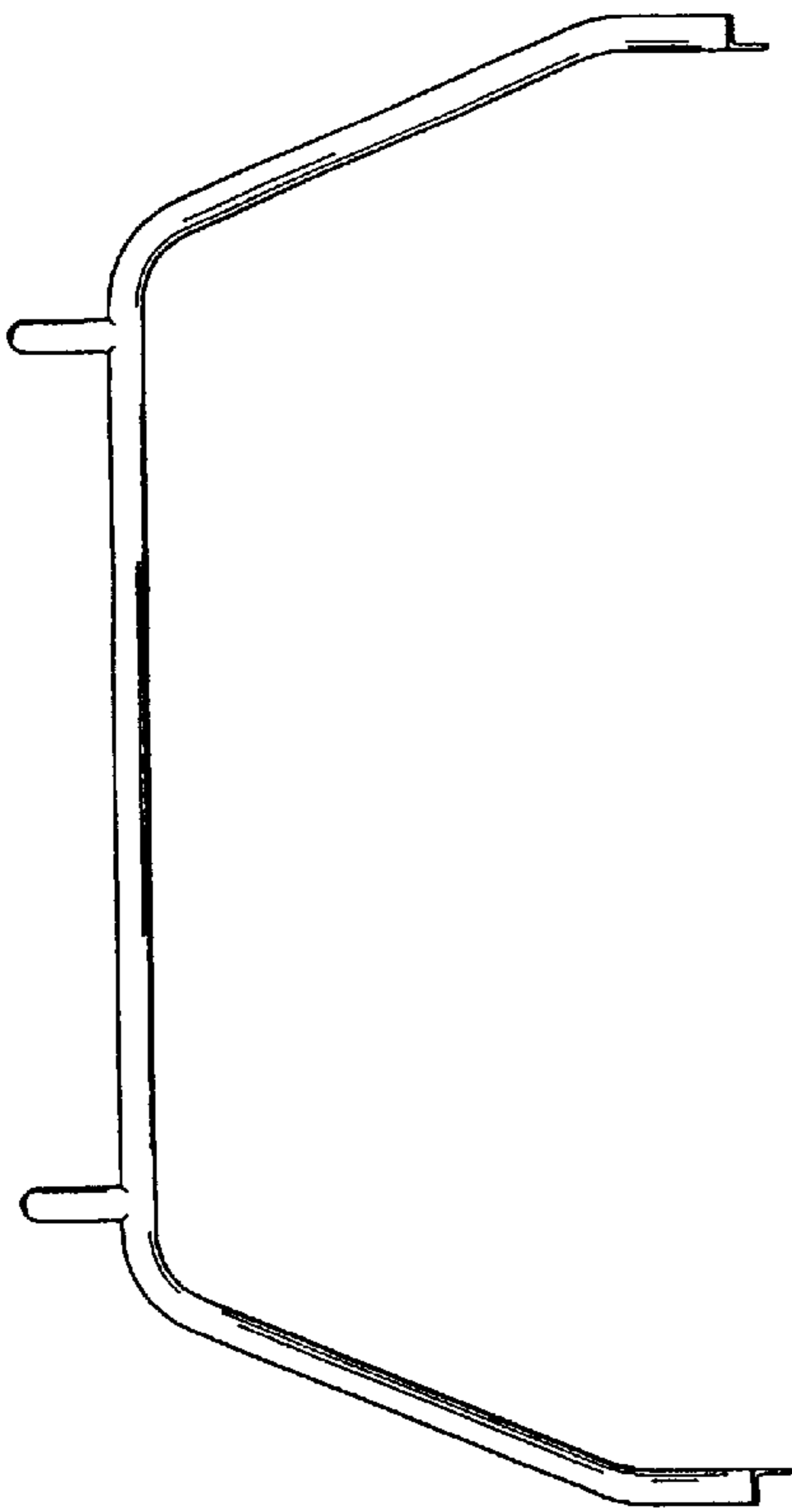

FIG. 6

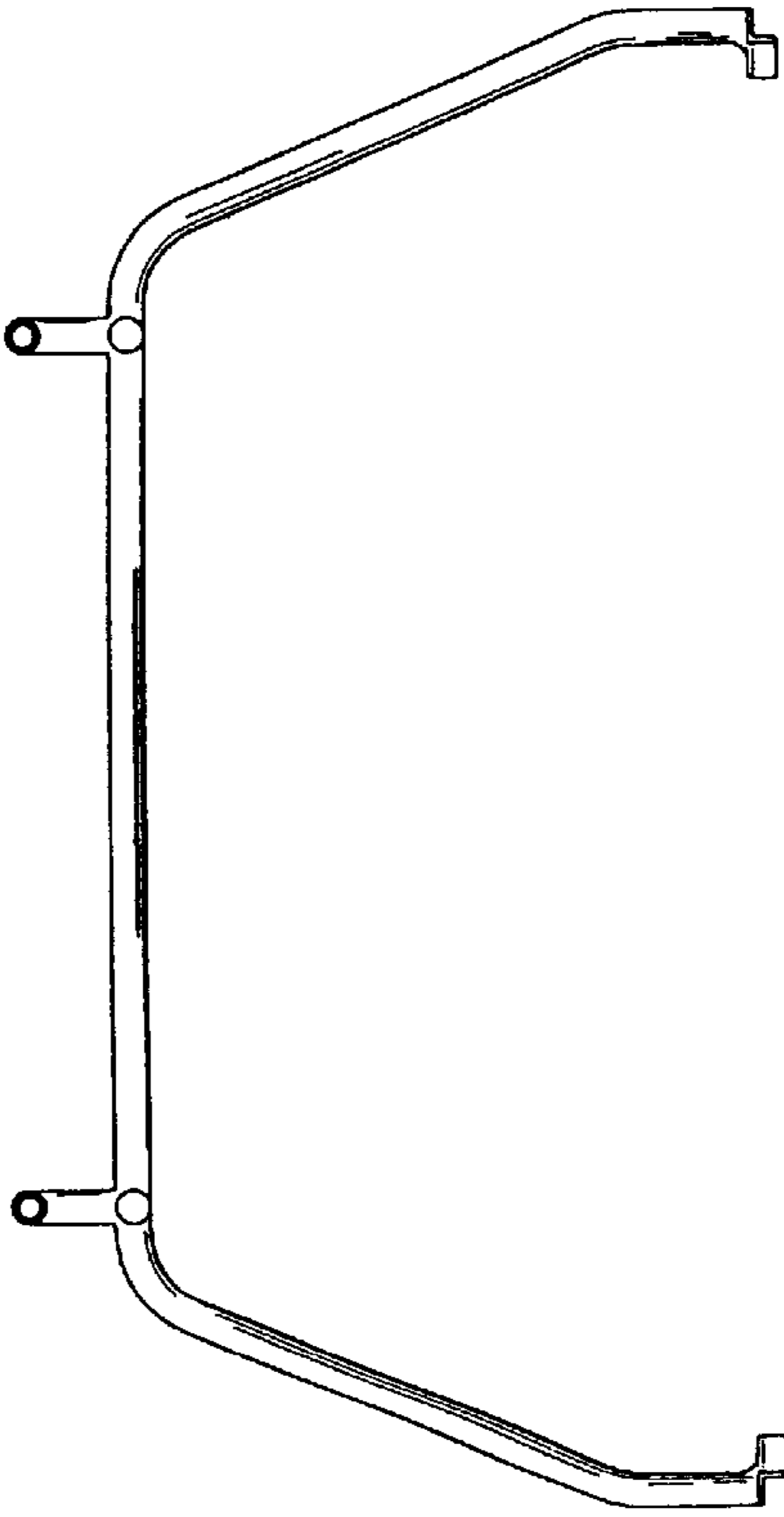

FIG. 8

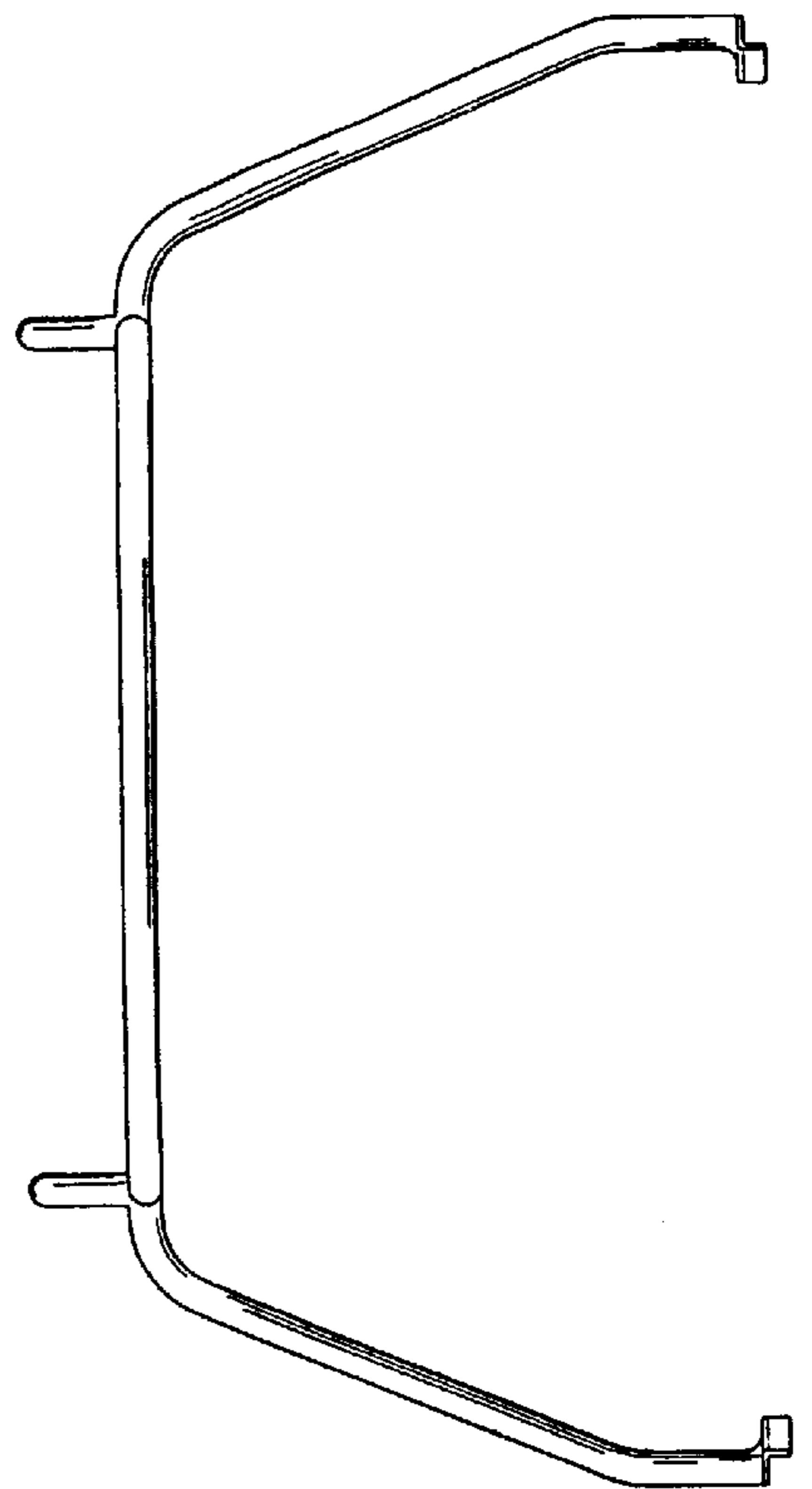

FIG. 7

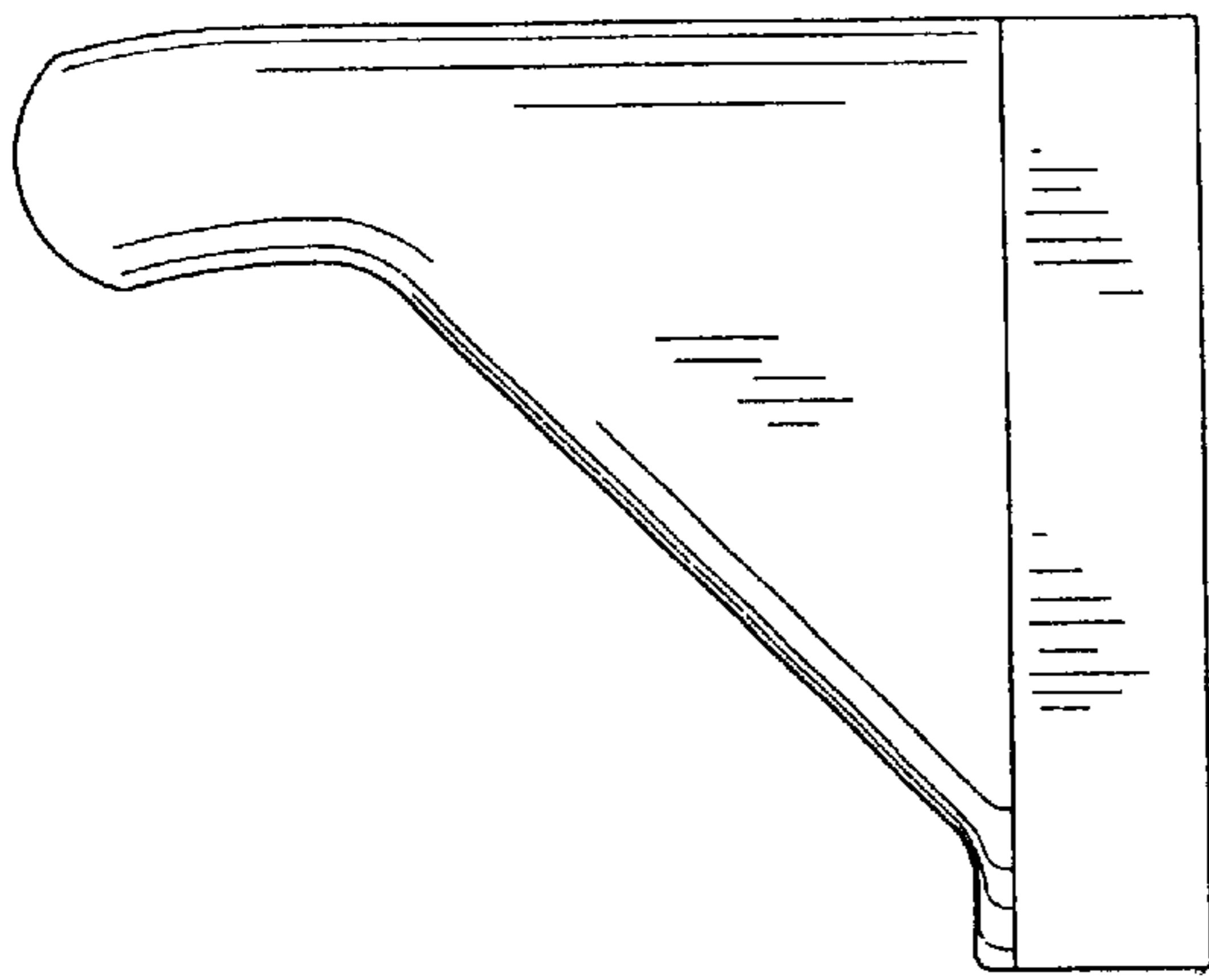

FIG. 9

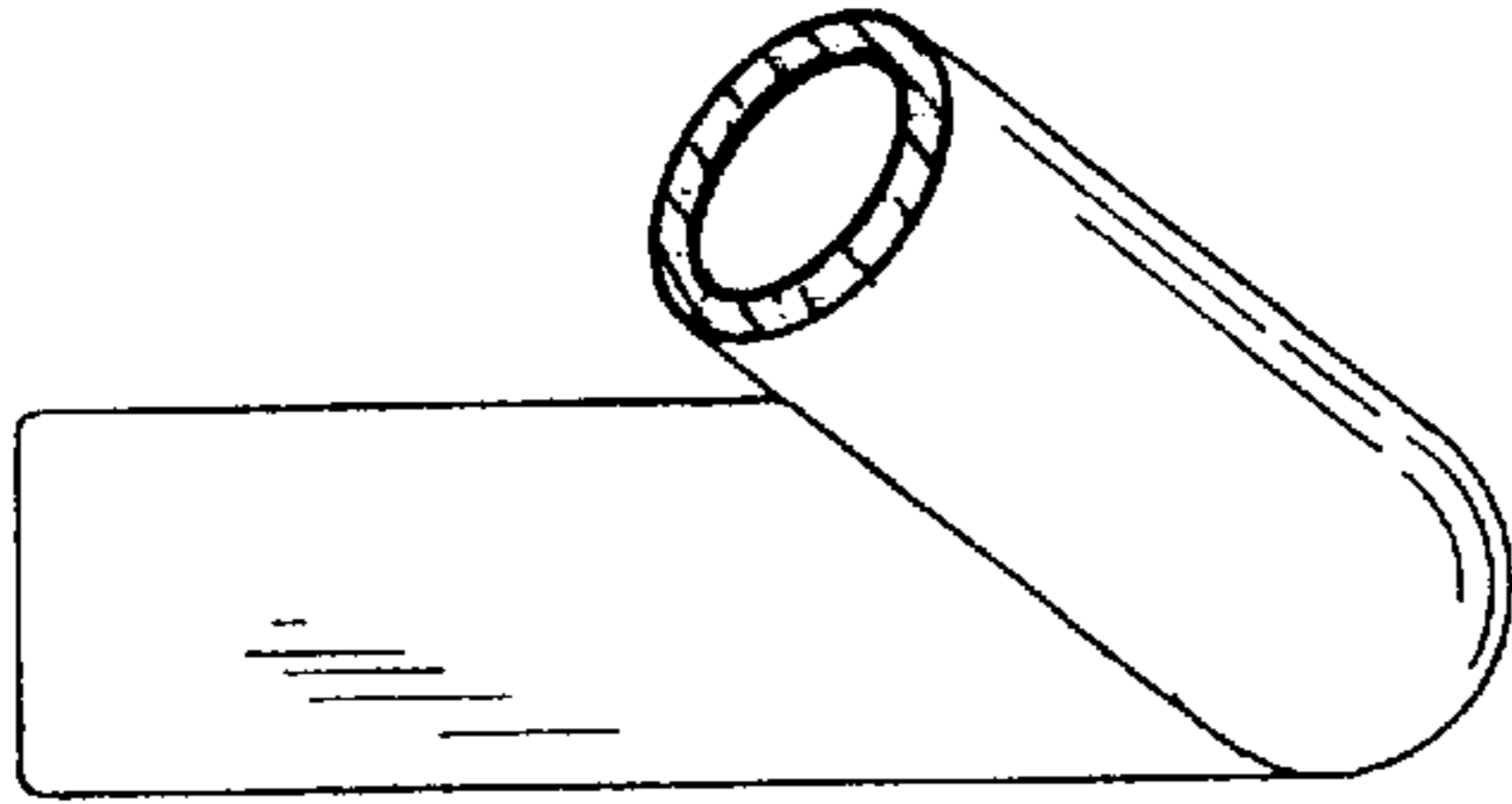

FIG. 10

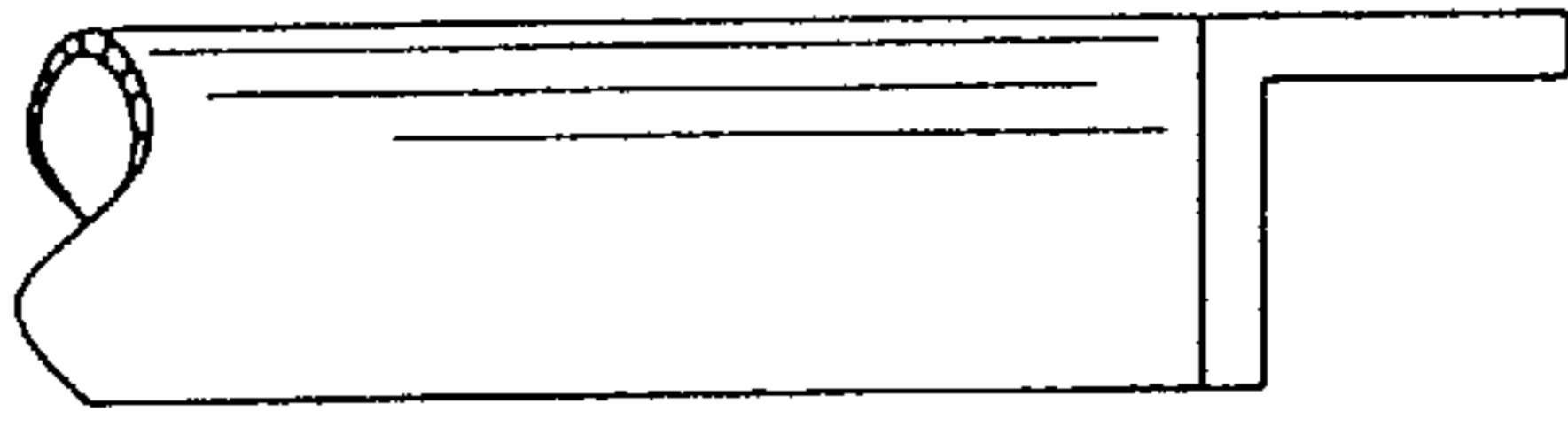

FIG. 11

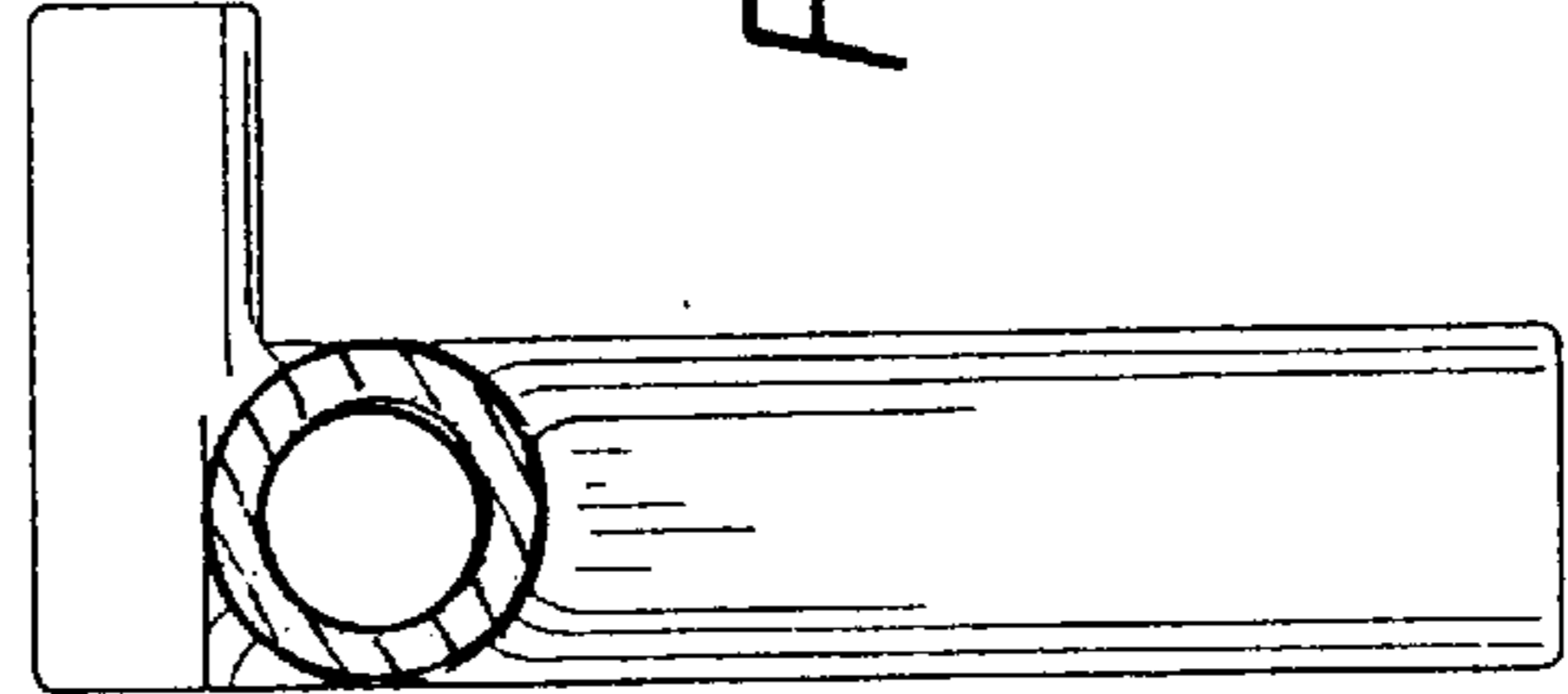

FIG. 13

FIG. 14

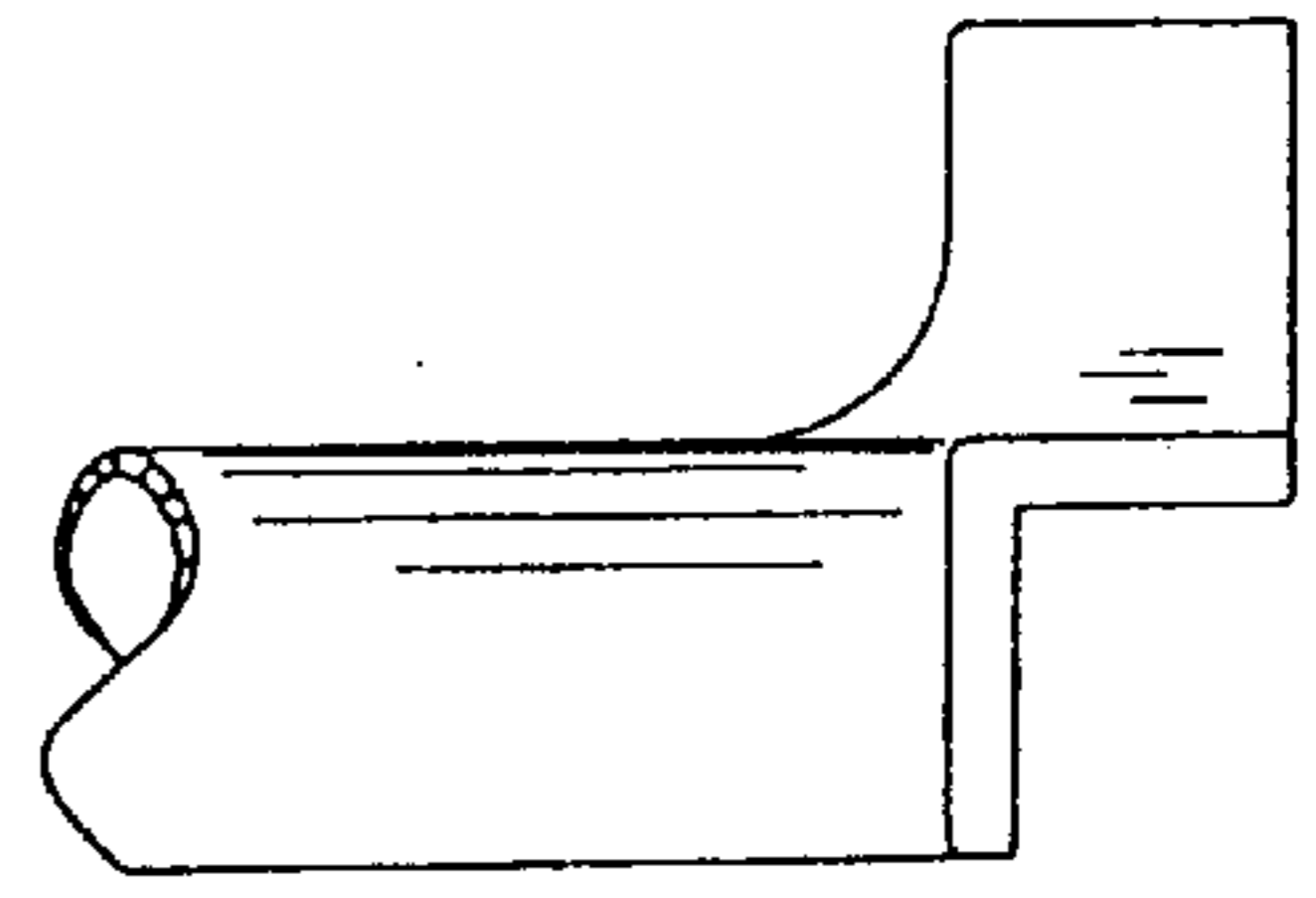

FIG. 12

