



US00D463348S

(12) **United States Design Patent**
Kataoka

(10) **Patent No.:** **US D463,348 S**

(45) **Date of Patent:** **** Sep. 24, 2002**

(54) **AUTOMOTIVE WHEEL**

D452,210 S * 12/2001 Bernoni D12/209
D452,470 S * 12/2001 Gabath D12/209

(75) Inventor: **Tatsuya Kataoka**, Ota Gunma (JP)

* cited by examiner

(73) Assignee: **Y. Kataoka Corp**, Torrance, CA (US)

Primary Examiner—Stacia Cadmus

(**) Term: **14 Years**

(74) *Attorney, Agent, or Firm*—G. Donald Weber, Jr.

(21) Appl. No.: **29/149,750**

(57) **CLAIM**

(22) Filed: **Oct. 18, 2001**

The ornamental design for an automotive wheel, as shown and described.

(51) **LOC (7) Cl.** **12-16**

(52) **U.S. Cl.** **D12/209**

(58) **Field of Search** D12/204-211;
301/37.1, 64.1, 65

DESCRIPTION

FIG. 1 is a perspective view of the automotive wheel of the instant invention; and,
FIG. 2 is a front view of the automotive wheel of the instant invention.

The broken line showing of environment is for illustrative purposes only and forms no part of the claimed design.

(56) **References Cited**

U.S. PATENT DOCUMENTS

D410,885 S * 6/1999 Fridie D12/209
D451,461 S * 12/2001 Arellano D12/209
D451,874 S * 12/2001 Donikoglu D12/209

1 Claim, 1 Drawing Sheet

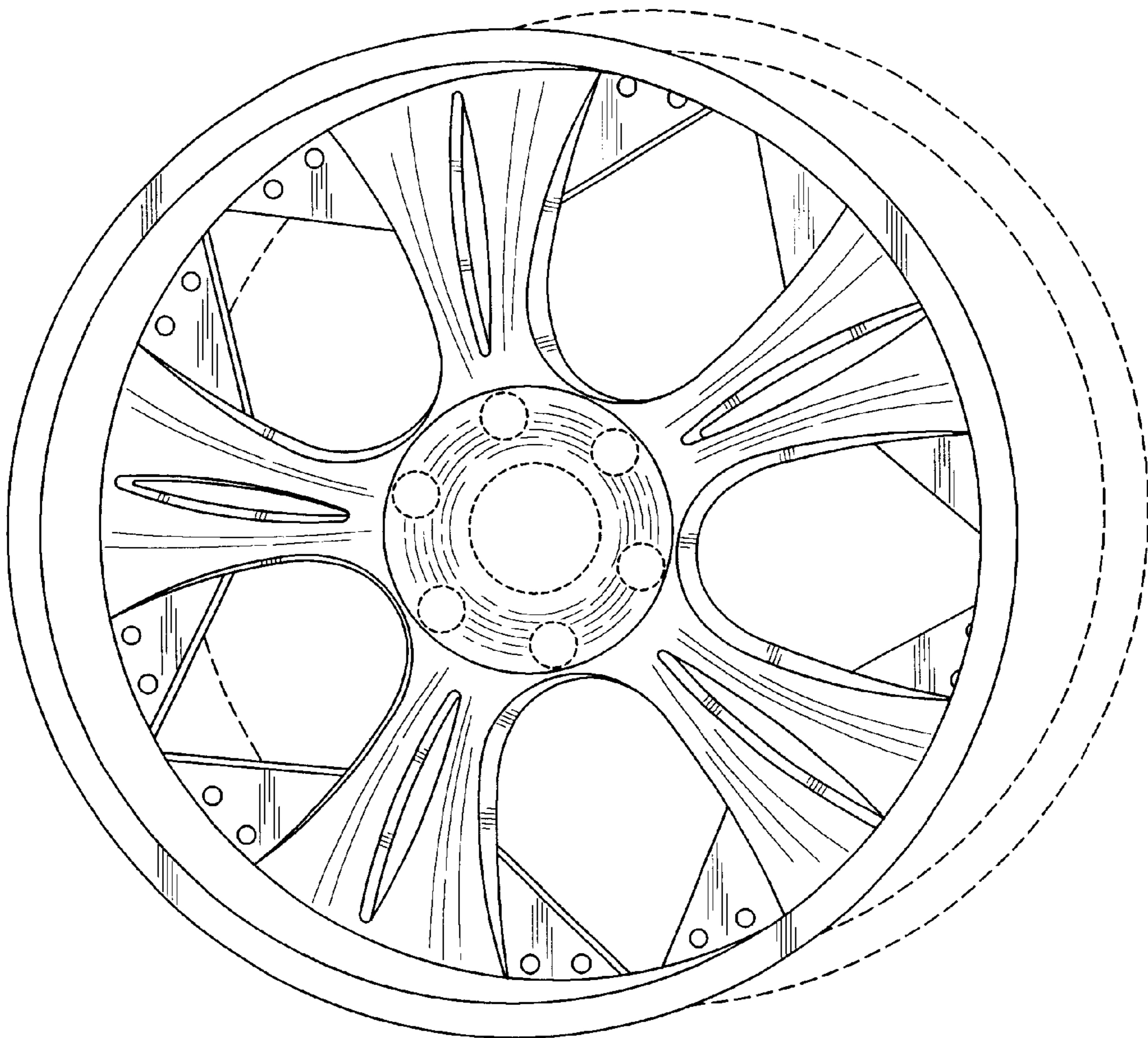

Fig. 1

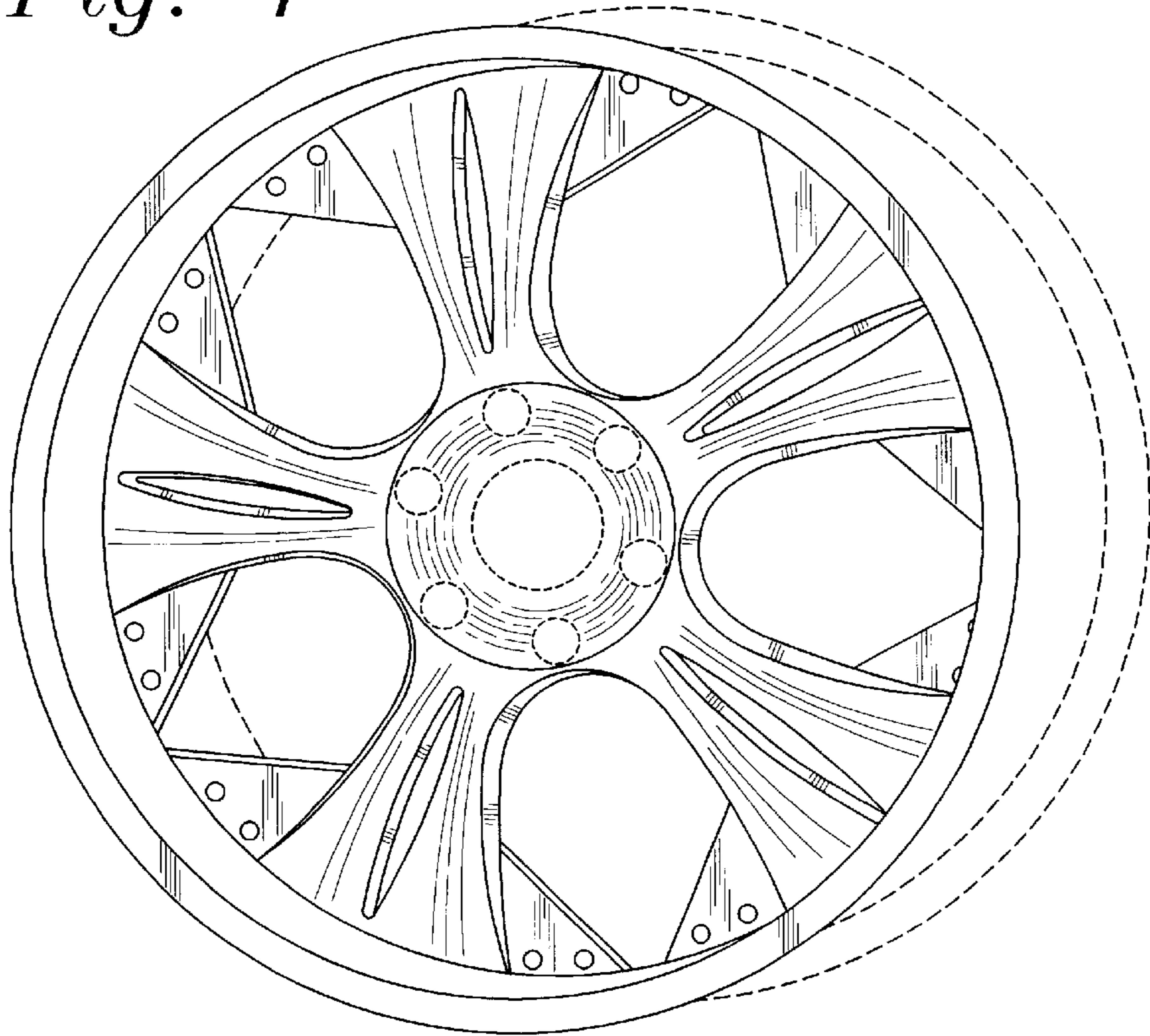

Fig. 2

