



US00D463339S

(12) **United States Design Patent**
Muraoka et al.

(10) **Patent No.:** **US D463,339 S**
(45) **Date of Patent:** **** Sep. 24, 2002**

(54) **ELECTROMAGNETIC POWDER CLUTCH**

6,318,513 B1 * 11/2001 Dietrich et al. 188/72.7

(75) Inventors: **Kazutoshi Muraoka**, Tokyo (JP);
Fumio Ono, Tokyo (JP); **Yoshiharu Kobayashi**, Tokyo (JP)

FOREIGN PATENT DOCUMENTS

JP 629221 4/1984

* cited by examiner

(73) Assignee: **Mitsubishi Denki Kabushiki Kaisha**, Tokyo (JP)

Primary Examiner—Melody N. Brown

(**) Term: **14 Years**

(74) *Attorney, Agent, or Firm*—Oblon, Spivak, McClelland, Maier & Neustadt, P.C.

(21) Appl. No.: **29/150,210**

(57) **CLAIM**

(22) Filed: **Nov. 14, 2001**

The ornamental design for an electromagnetic powder clutch, as shown and described.

(30) **Foreign Application Priority Data**

DESCRIPTION

Jun. 29, 2001 (JP) 2001-019065

(51) **LOC (7) Cl.** **12-16**

(52) **U.S. Cl.** **D12/180**

(58) **Field of Search** D12/180; 188/722, 188/727, 728, 70 B, 111, 156, 138, 162, 344; 210/136, 304, 305

FIG. 1 is a front, top and left side perspective view of an electromagnetic powder clutch, showing our new design; FIG. 2 is a rear, top and left side perspective view thereof; FIG. 3 is a front elevational view thereof; FIG. 4 is a rear elevational view thereof; FIG. 5 is a top plan view thereof, the bottom plan view is omitted as that is symmetrical to the top plan view thereof; and, FIG. 6 is a right side elevational view thereof, the left side elevational view is omitted as that is symmetrical to the right side elevational view thereof.

(56) **References Cited**

U.S. PATENT DOCUMENTS

D271,292 S * 11/1983 Wilson et al. D12/180
6,116,797 A * 9/2000 Brewington et al. . 192/104 C X
6,244,394 B1 * 6/2001 Gutierrez et al. 188/72.8

1 Claim, 3 Drawing Sheets

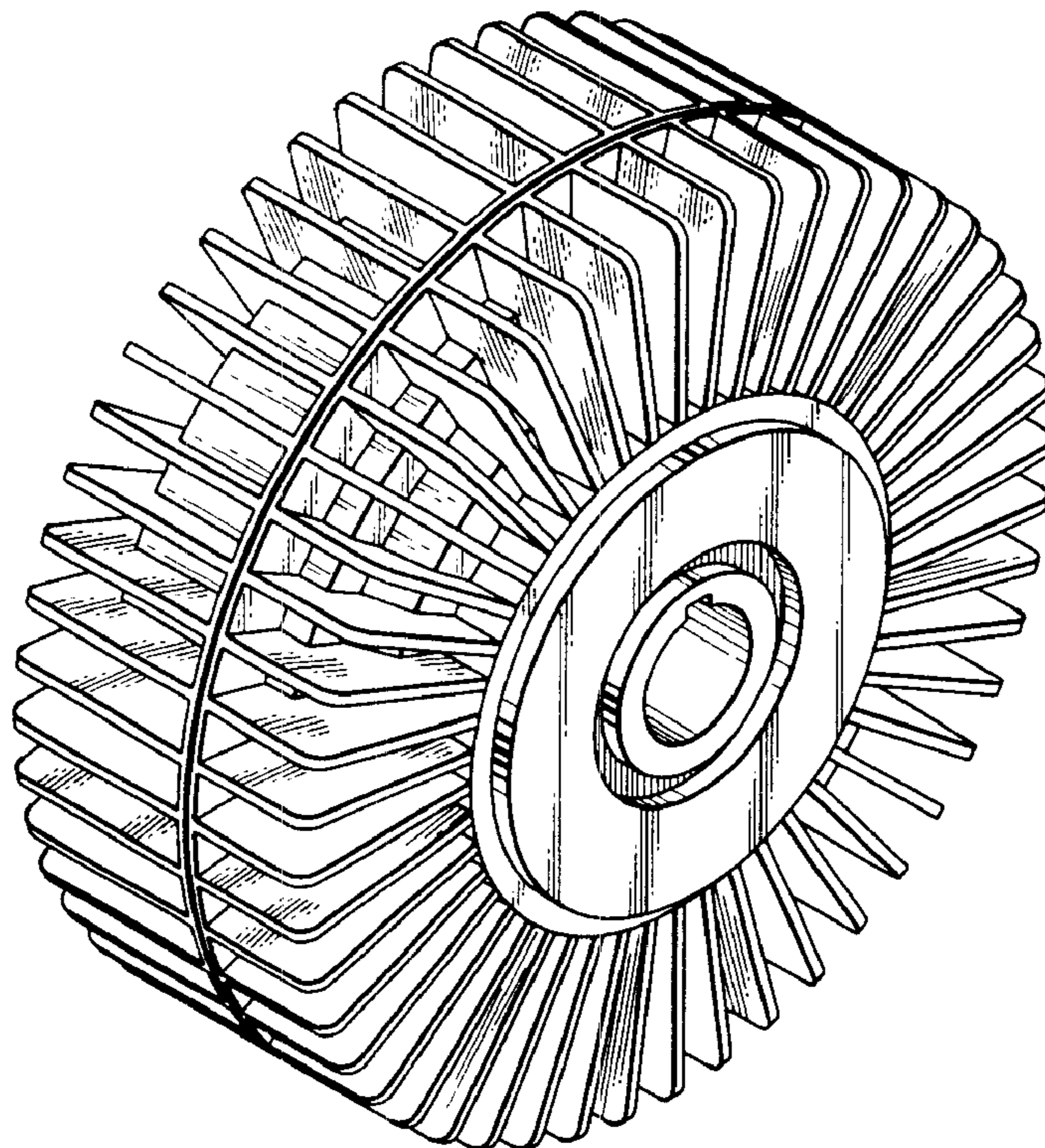

FIG. 1

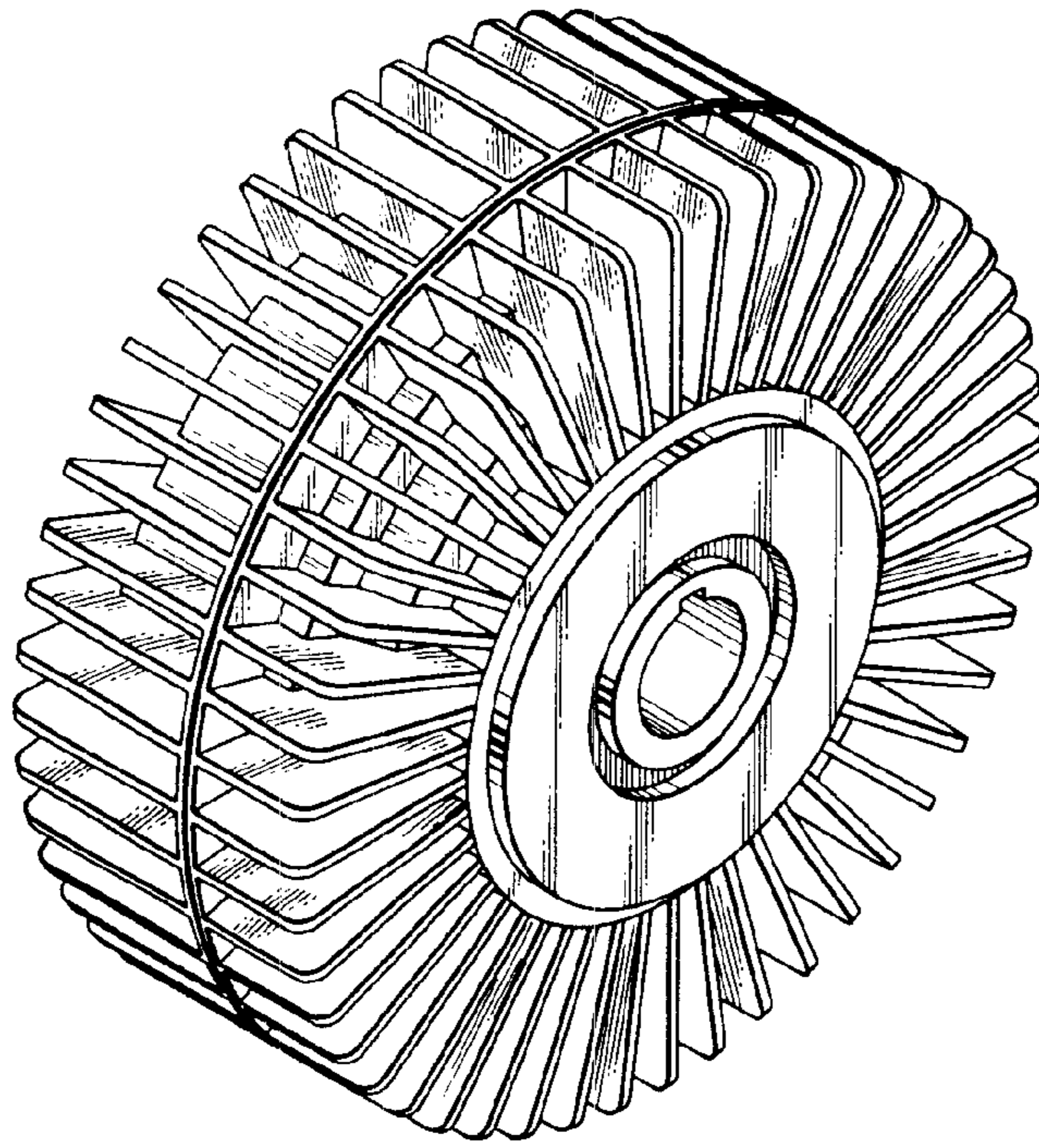

FIG. 2

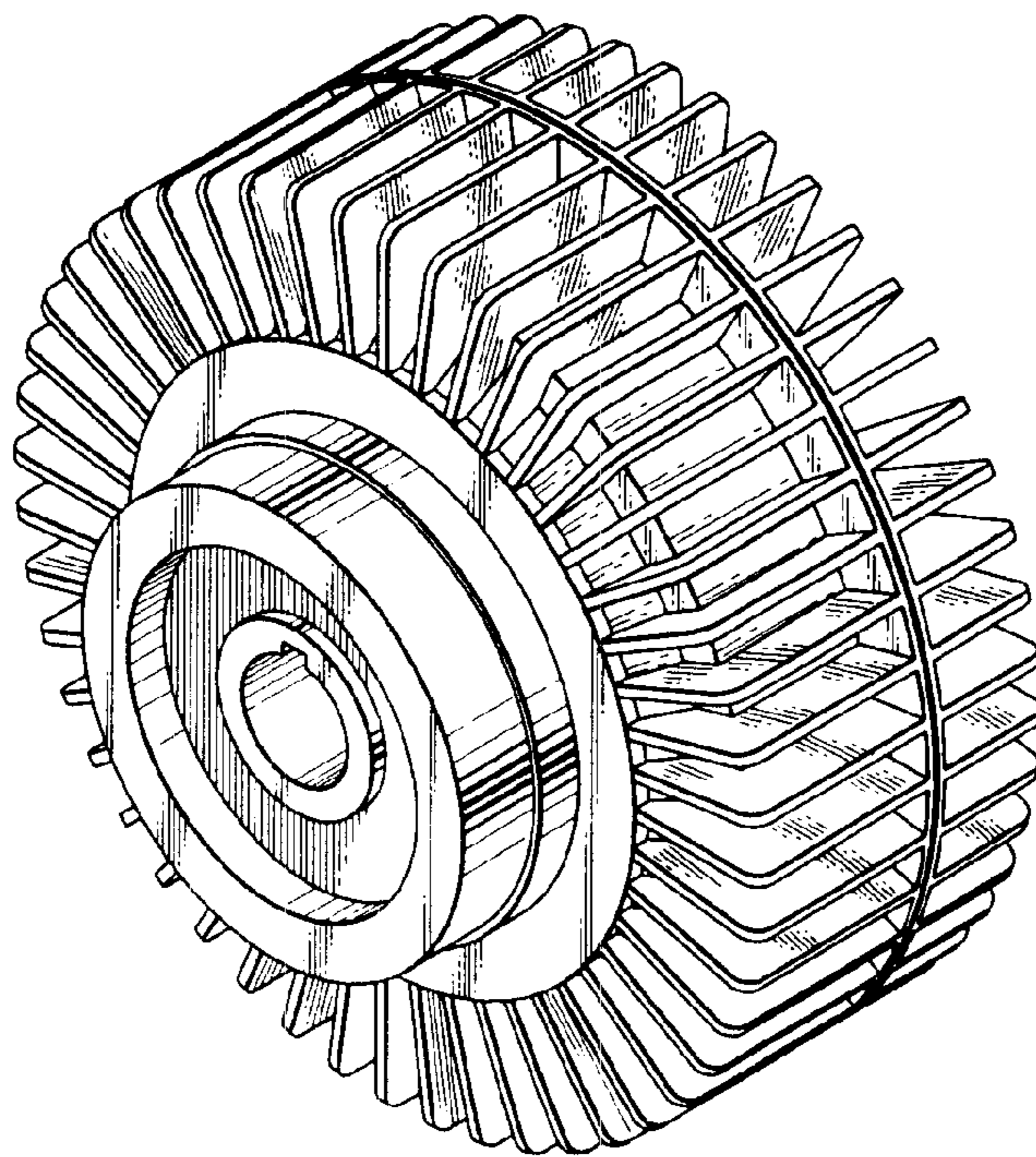

FIG. 3

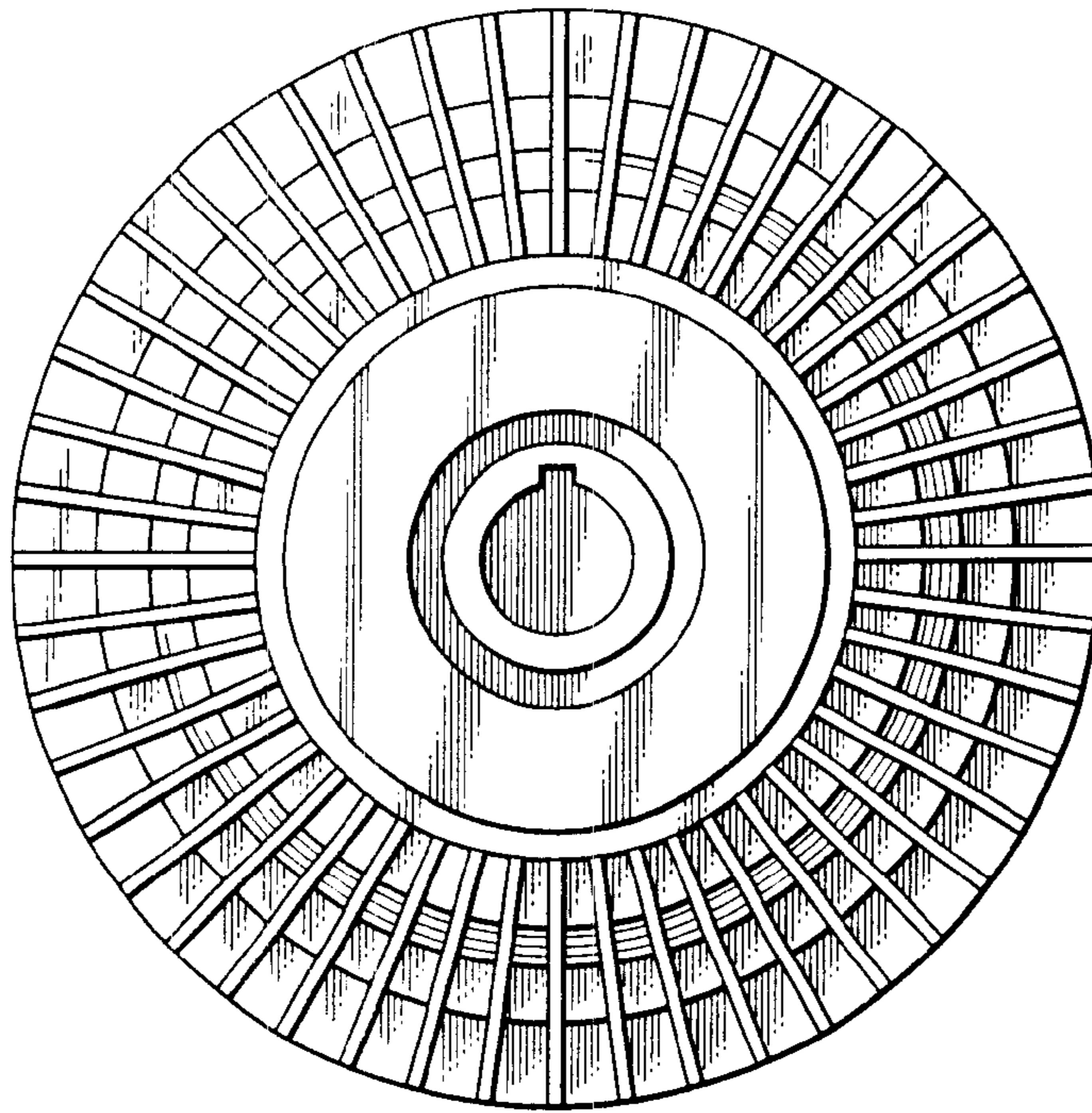

FIG. 4

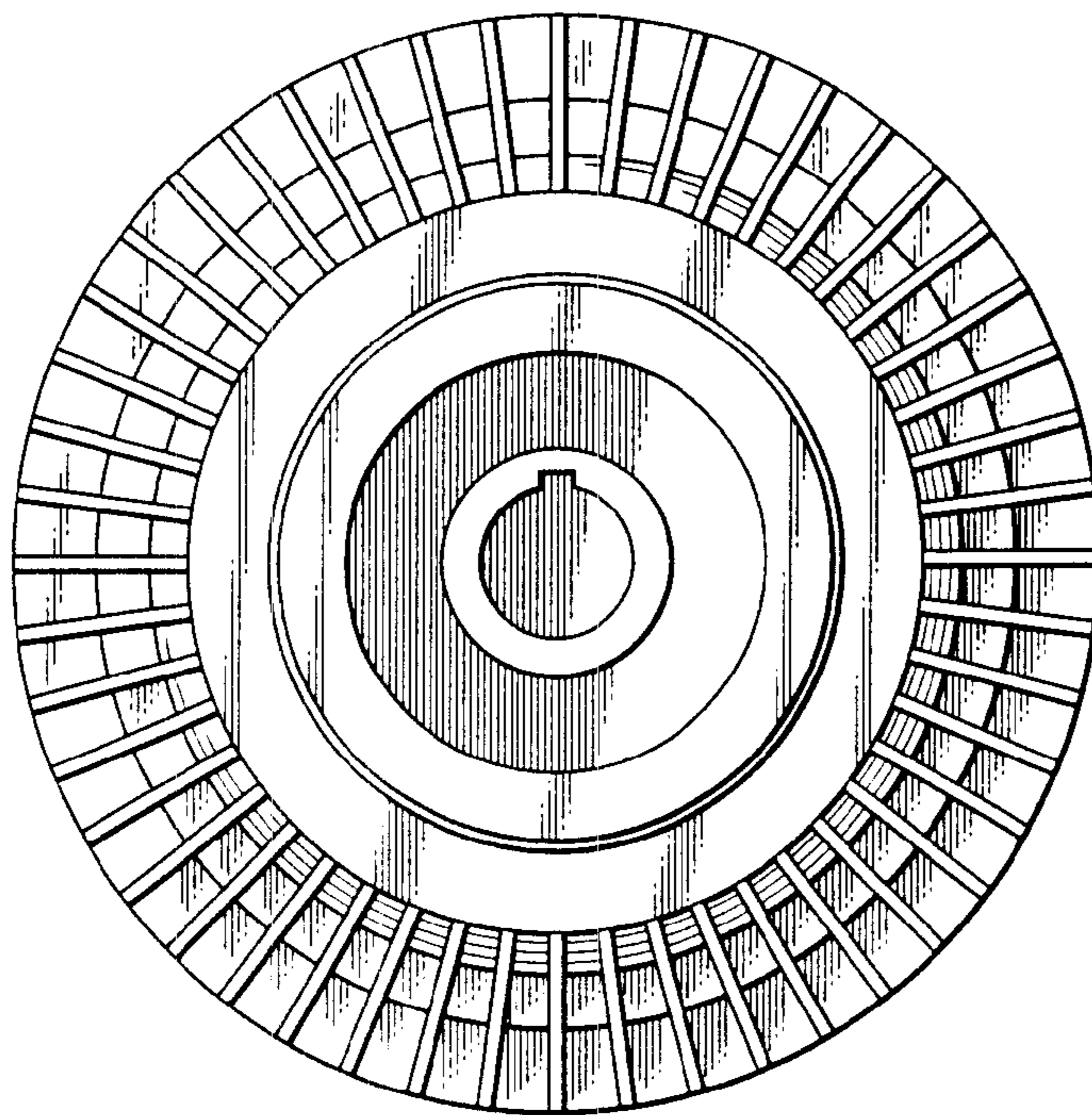

FIG. 5

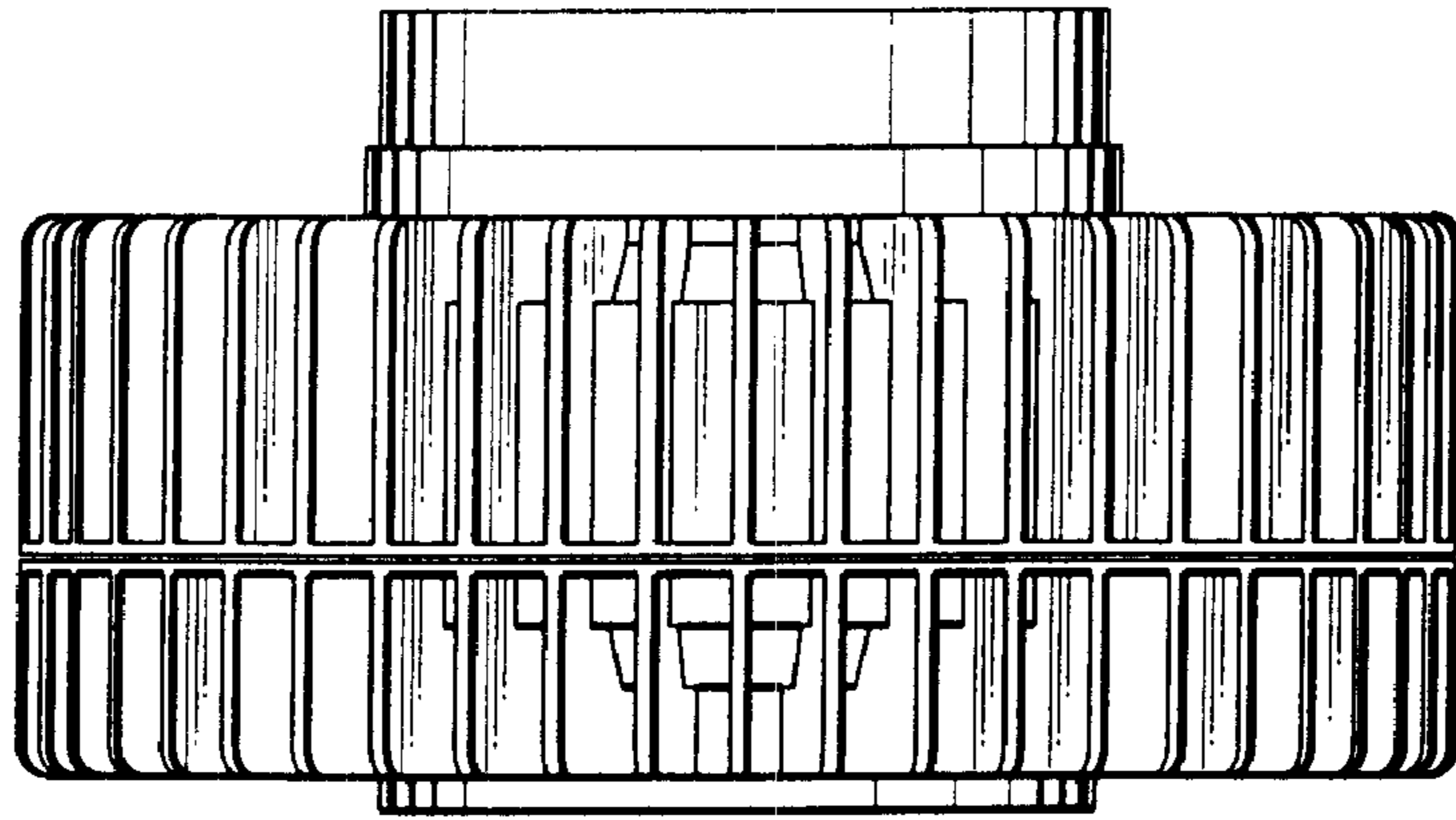

FIG. 6

