



US00D46338S

(12) **United States Design Patent**  
**Ioka et al.**

(10) **Patent No.:** **US D463,338 S**

(45) **Date of Patent:** **\*\* Sep. 24, 2002**

(54) **ELECTROMAGNETIC POWDER BRAKE**

5,791,442 A \* 8/1998 Arnold ..... 188/138

6,244,394 B1 \* 6/2001 Gutierrez et al. .... 188/72.8

6,318,513 B1 \* 11/2001 Dietrich et al. .... 188/72.7

(75) Inventors: **Kouichi Ioka**, Tokyo (JP); **Fumio Ono**,  
Tokyo (JP); **Yoshiharu Kobayashi**,  
Tokyo (JP)

**FOREIGN PATENT DOCUMENTS**

JP 57-12146 3/1982

\* cited by examiner

*Primary Examiner*—Melody N. Brown

(74) *Attorney, Agent, or Firm*—Oblon, Spivak, McClelland,  
Maier & Neustadt, P.C.

(73) Assignee: **Mitsubishi Denki Kabushiki Kaisha**,  
Tokyo (JP)

(\*\*) Term: **14 Years**

(57) **CLAIM**

(21) Appl. No.: **29/150,208**

The ornamental design for an electromagnetic powder  
brake, as shown and described.

(22) Filed: **Nov. 14, 2001**

**DESCRIPTION**

(30) **Foreign Application Priority Data**

Jun. 29, 2001 (JP) ..... 2001-019064

FIG. 1 is a front, top and left side perspective view of an  
electromagnetic powder brake, showing our new design;  
FIG. 2 is a rear, top and left side perspective view thereof;  
FIG. 3 is a front elevational view thereof;  
FIG. 4 is a rear elevational view thereof;  
FIG. 5 is a top plan view thereof;  
FIG. 6 is a bottom plan view thereof; and,  
FIG. 7 is a right side elevational view thereof, the left side  
elevational view is omitted as that is symmetrical to the right  
side elevational view thereof.

(51) **LOC (7) Cl.** ..... **12-16**

(52) **U.S. Cl.** ..... **D12/180**

(58) **Field of Search** ..... D12/180; 188/72.2,  
188/72.7, 72.8, 70 B, 111, 138, 156, 162;  
210/136, 304, 305; 192/103 A, 104 C, 105 CD,  
70.26

(56) **References Cited**

**U.S. PATENT DOCUMENTS**

D271,292 S \* 11/1983 Wilson et al. .... D12/180

4,974,705 A \* 12/1990 Le Pensee ..... 188/138

**1 Claim, 4 Drawing Sheets**

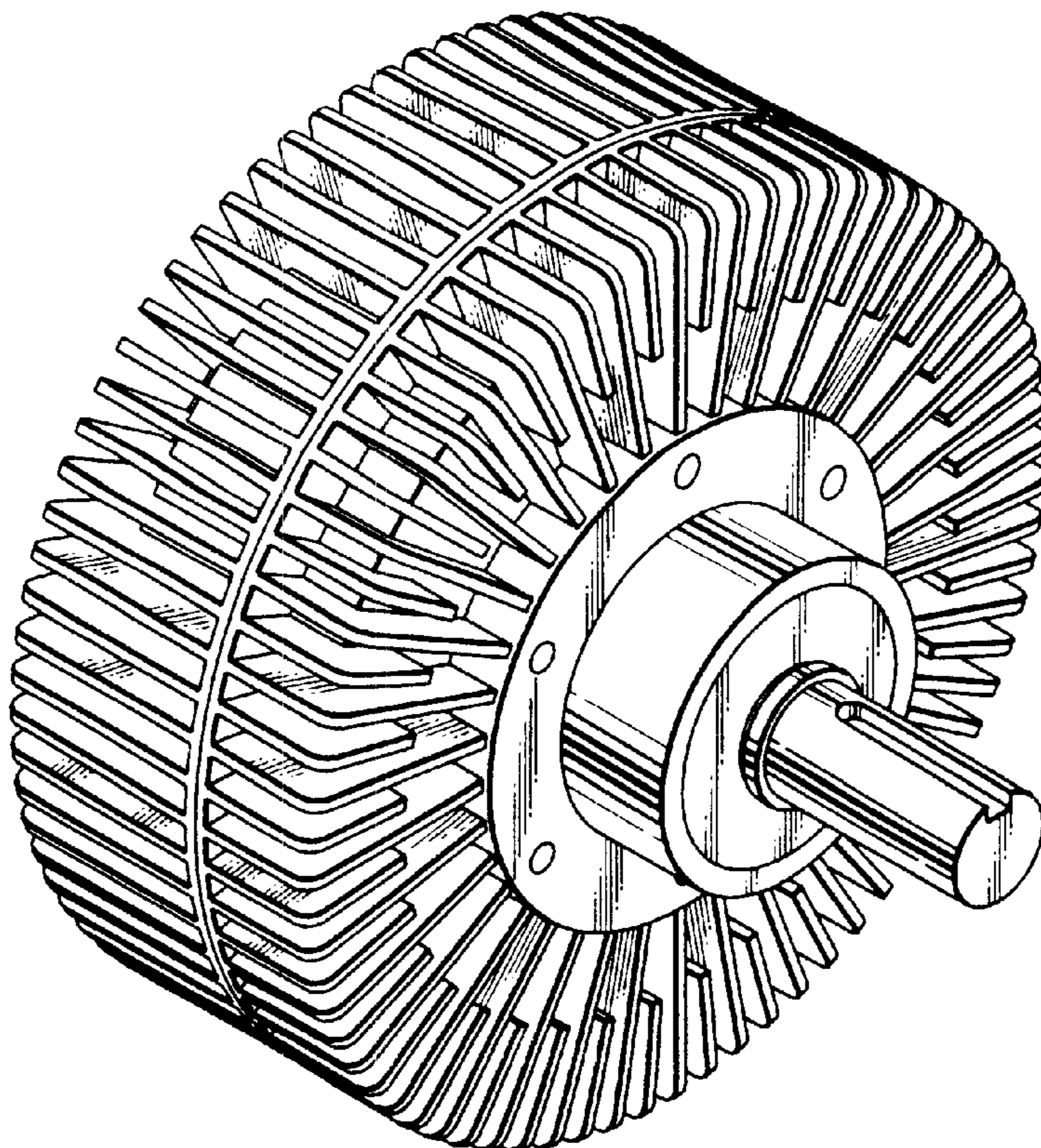

FIG. 1

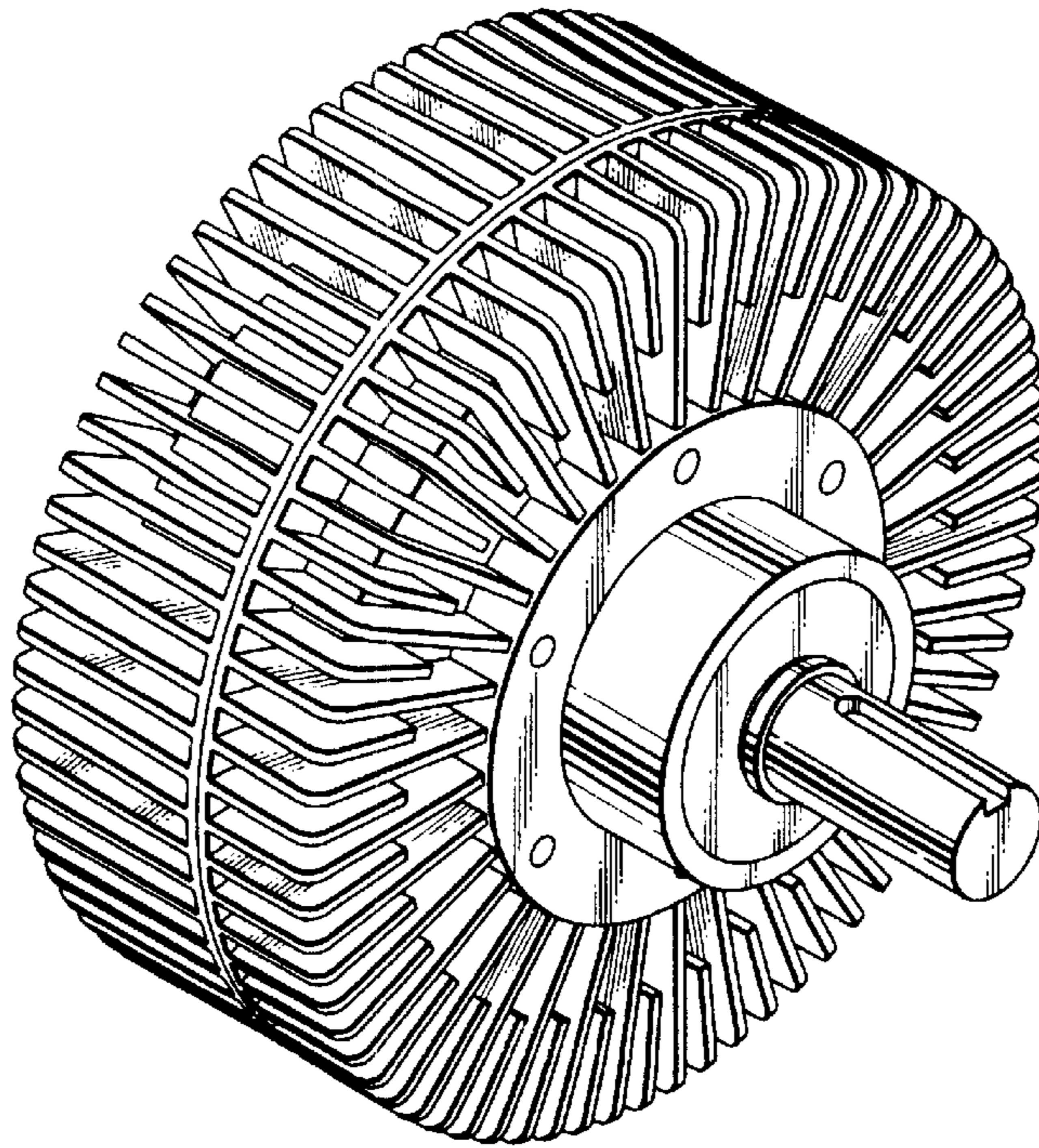

FIG. 2

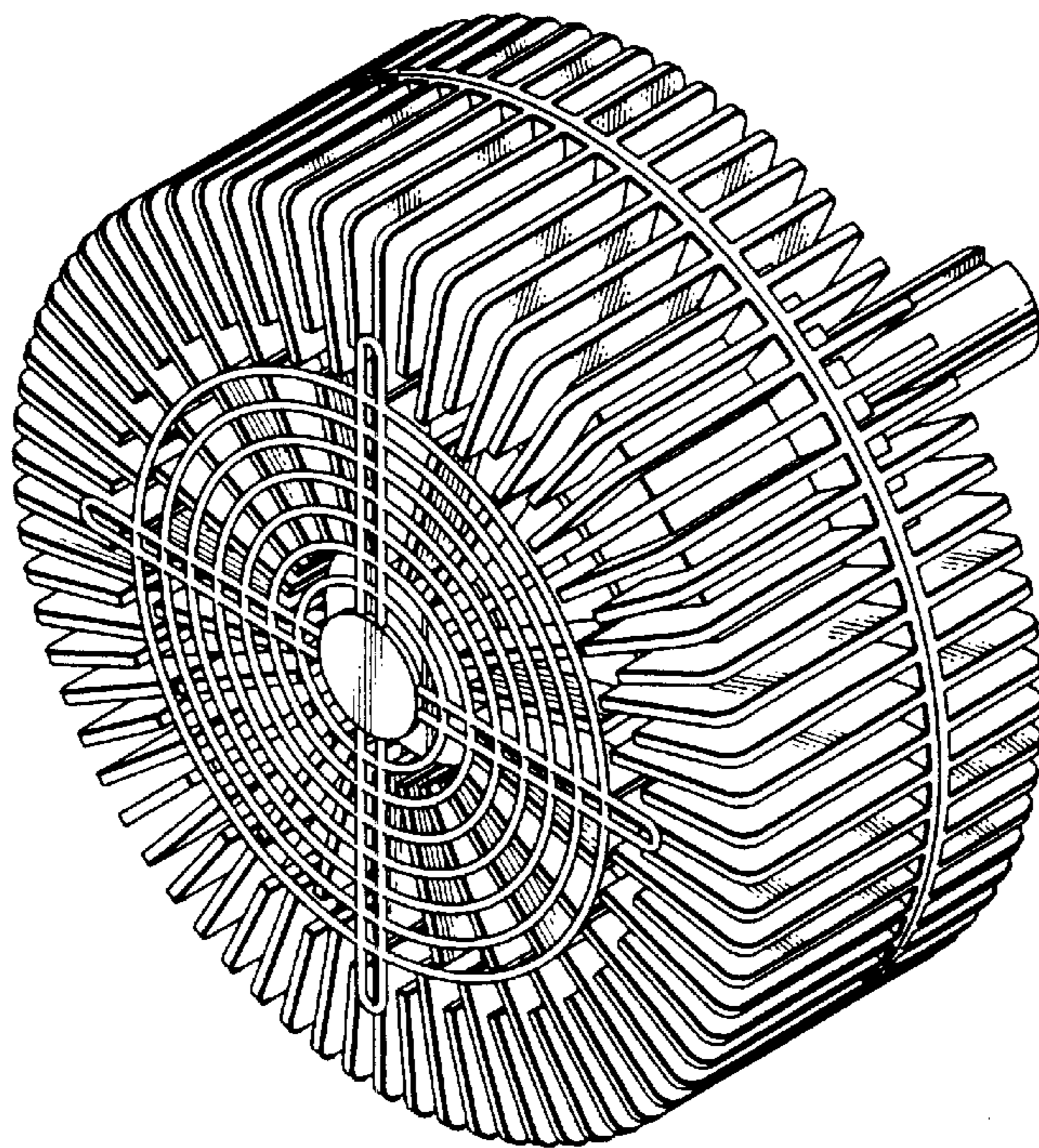

FIG. 3

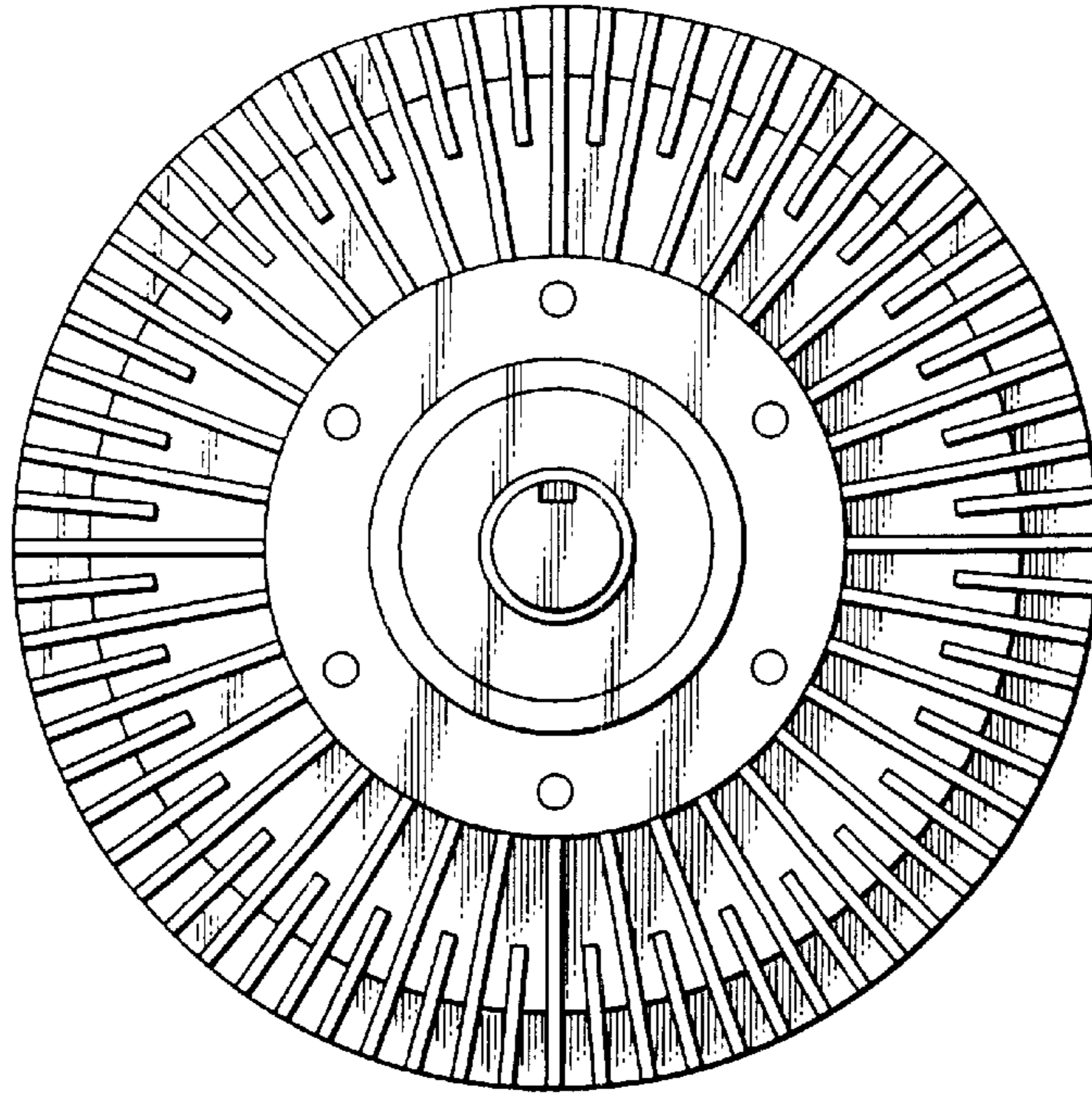

FIG. 4

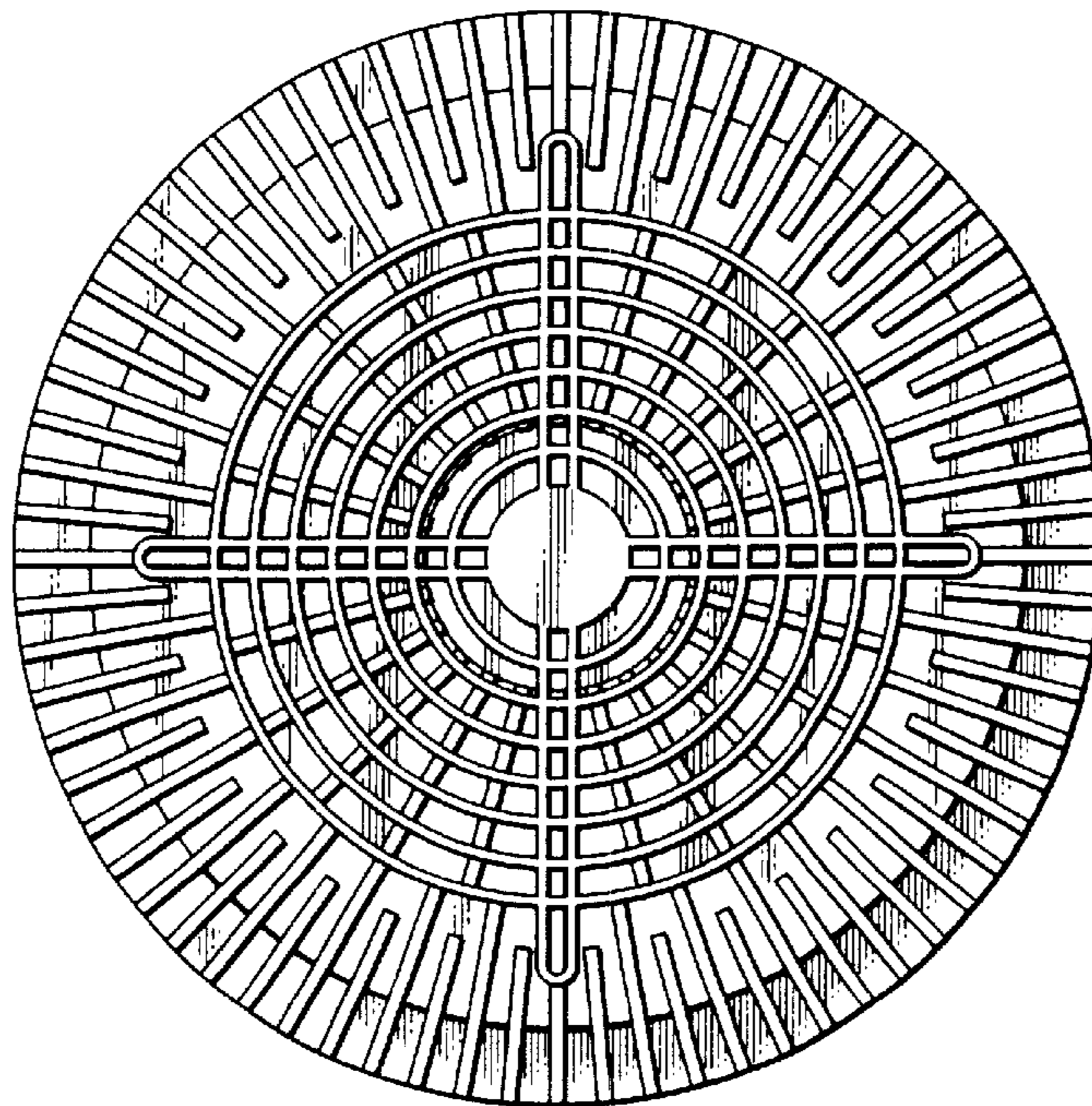

FIG. 5

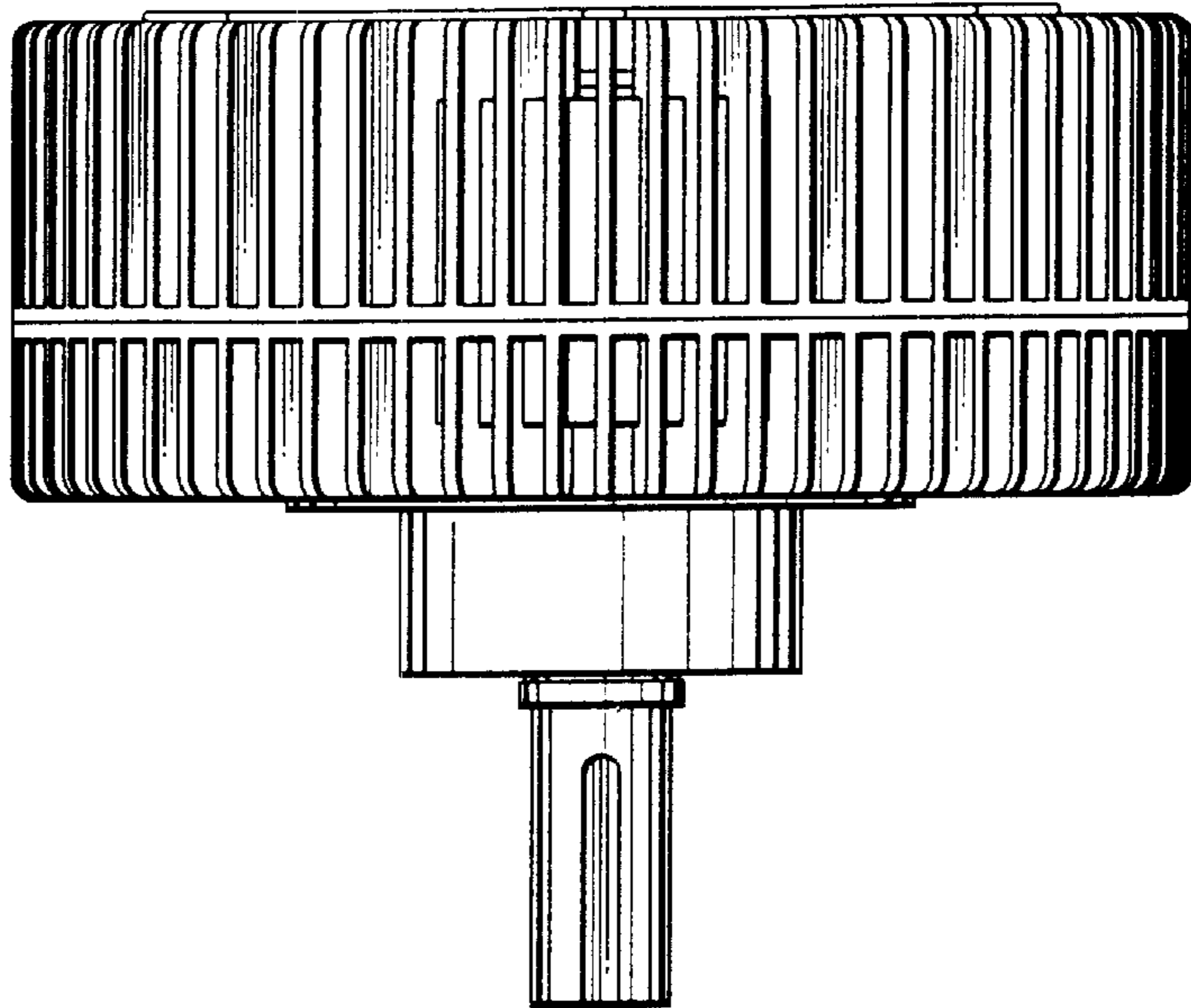

FIG. 6

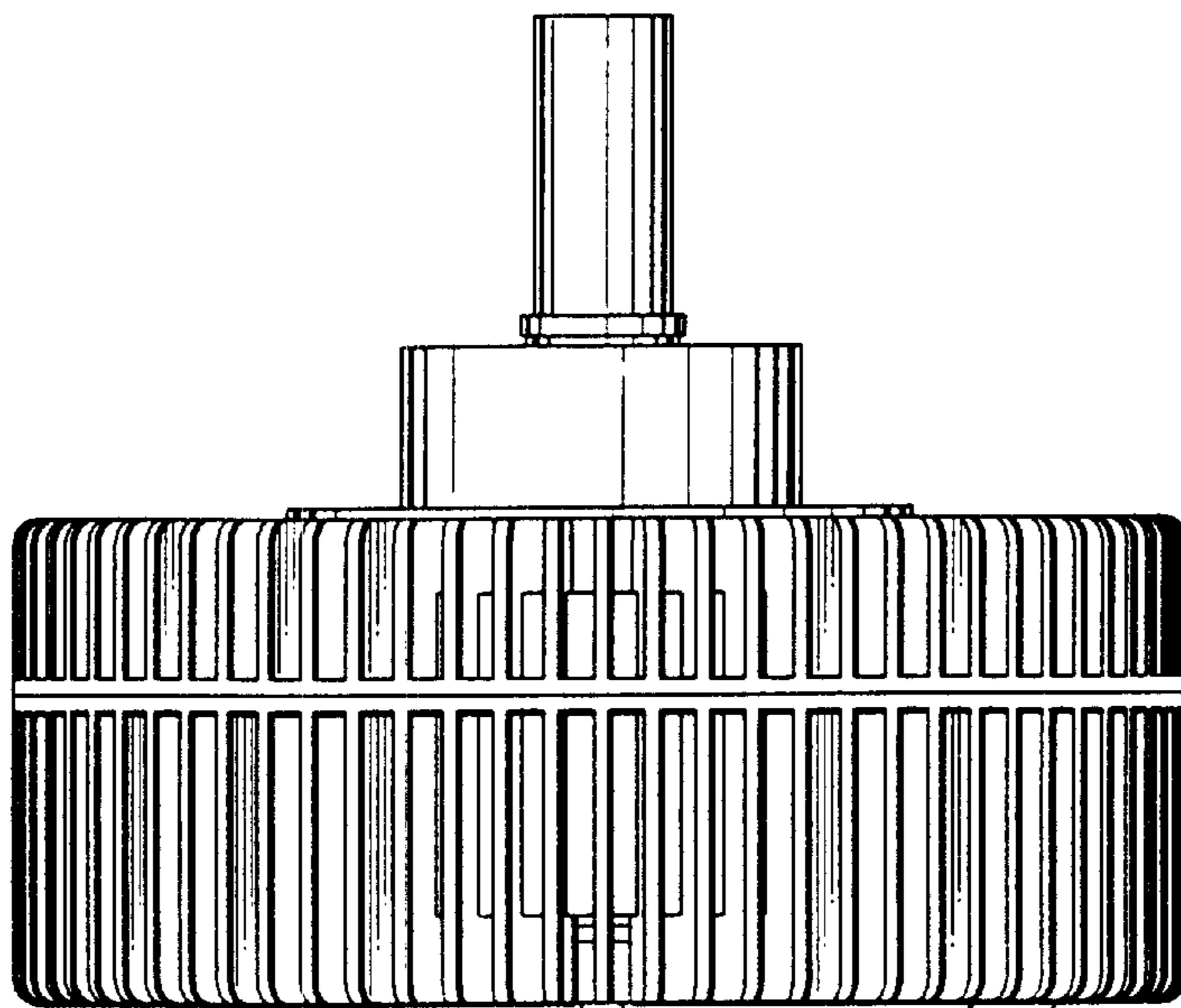

FIG. 7

