



US00D463237S

(12) **United States Design Patent**  
**Sims et al.**

(10) **Patent No.:** **US D463,237 S**

(45) **Date of Patent:** **\*\* Sep. 24, 2002**

(54) **PNEUMATIC FASTENER DRIVING TOOL BODY**

(75) Inventors: **Kelso G. Sims**, Crystal Lake, IL (US);  
**Jeffrey P. Heuel**, Elmhurst, IL (US)

(73) Assignee: **Peace Industries, Ltd.**, Rolling Meadows, IL (US)

(\*\*) Term: **14 Years**

(21) Appl. No.: **29/135,231**

(22) Filed: **Jan. 5, 2001**

(51) **LOC (7) Cl.** ..... **08-05**

(52) **U.S. Cl.** ..... **D8/68**

(58) **Field of Search** ..... D8/49, 61, 62, D8/63, 64, 65, 66, 67, 68, 69, 70; 16/430; 30/388; 81/52, 54, 55, 57.11, 57.13, 57.14, 57.33, 57.42, 73, 177.1, 177.8, 177.85, 409, 429, 436, 464, 467, 469, 470, 900, 901, DIG. 12; 173/13, 15, 19, 47, 48, 81, 93, 93.5, 93.6, 94, 104, 109, 168, 169, 170, 171, 176, 178, 180, 181, 213, 216, 217, 221; 227/2, 8, 10, 66, 111, 112, 113, 114, 115, 120, 130, 136; 400/156, 181; 408/20, 120, 122, 124, 125, 234, 241 R, 241 S; 451/344, 354, 357, 358, 359, 456

(56) **References Cited**

**U.S. PATENT DOCUMENTS**

D420,878 S \* 2/2000 Li ..... D8/69  
D436,819 S \* 1/2001 Liu ..... D8/68  
D448,264 S \* 9/2001 Lee ..... D8/69

**OTHER PUBLICATIONS**

Spotnails Brochure, Cover, pp. 3–10, Nov. 2000.  
Bostitch Construction Line Catalog, Cover, pp. 4–9, Aug. 1996.

Hitachi Catalog, Cover, pp. 50–53, May 1998.

MAX Brochure, prior to Oct. 2000.

Jamerco Brochure, prior to Apr. 2000.

Accuset Brochure, Cover and double page photograph, May 2000.

Paslode Brochure, Cover, 1998.

\* cited by examiner

*Primary Examiner*—Doris V. Coles

*Assistant Examiner*—T. Chase Nelson

(74) *Attorney, Agent, or Firm*—Wood, Phillips, Katz, Clark & Mortimer

(57) **CLAIM**

The ornamental design for a pneumatic fastener driving tool body, as shown and described.

**DESCRIPTION**

FIG. 1 is a perspective view of a pneumatic fastener driving tool body showing our new design;

FIG. 2 is an end elevation view thereof from the left of FIG. 1;

FIG. 3 is an end elevation view thereof from the right of FIG. 1;

FIG. 4 is a top plan view thereof;

FIG. 5 is a side elevation view thereof from the right of FIG. 2;

FIG. 6 is a side elevation view thereof from the left of FIG. 2; and,

FIG. 7 is a bottom plan view thereof.

The driving mechanism, magazine and brace shown in dashed lines form no part of the design.

**1 Claim, 3 Drawing Sheets**

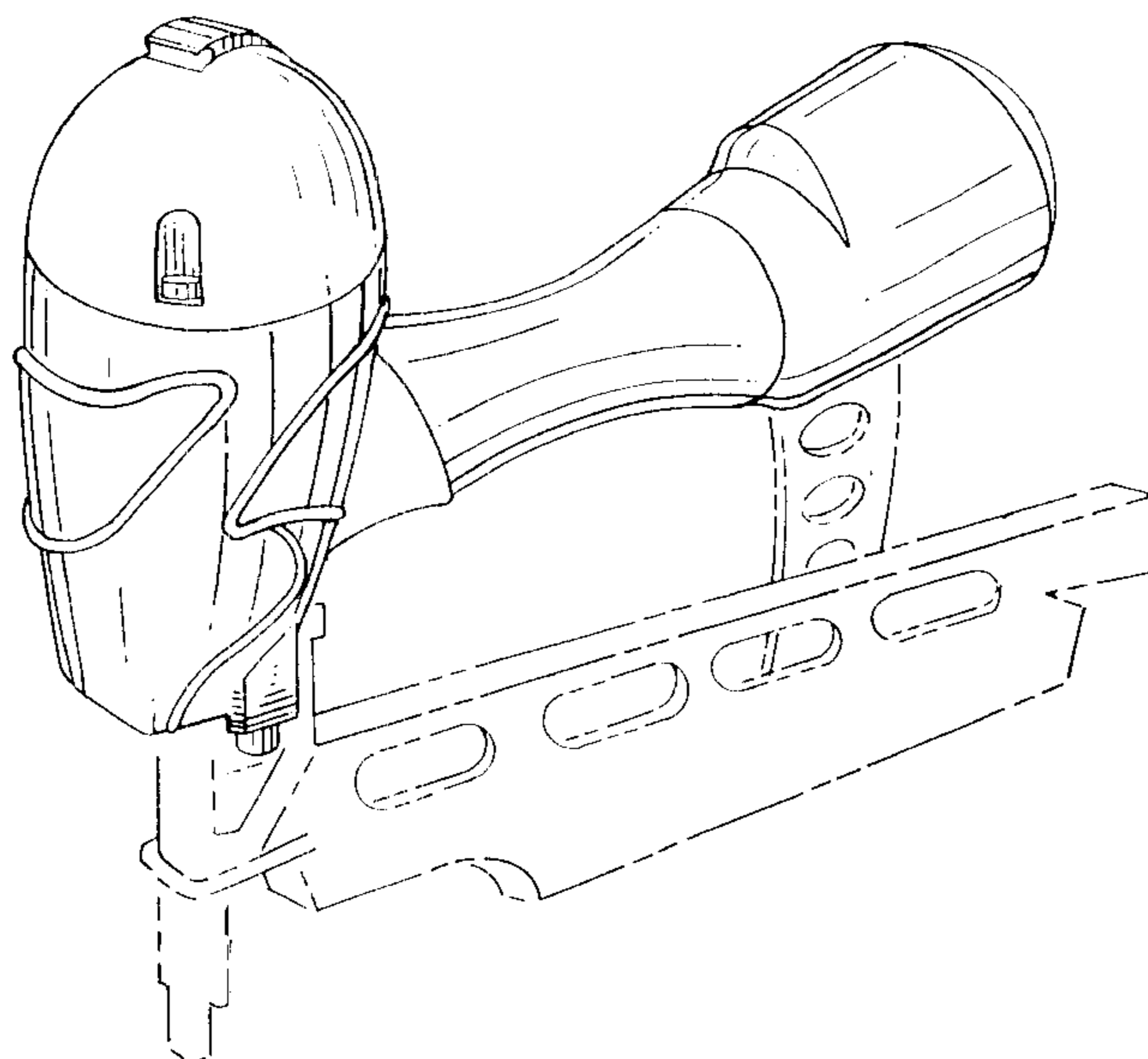

FIG. 1

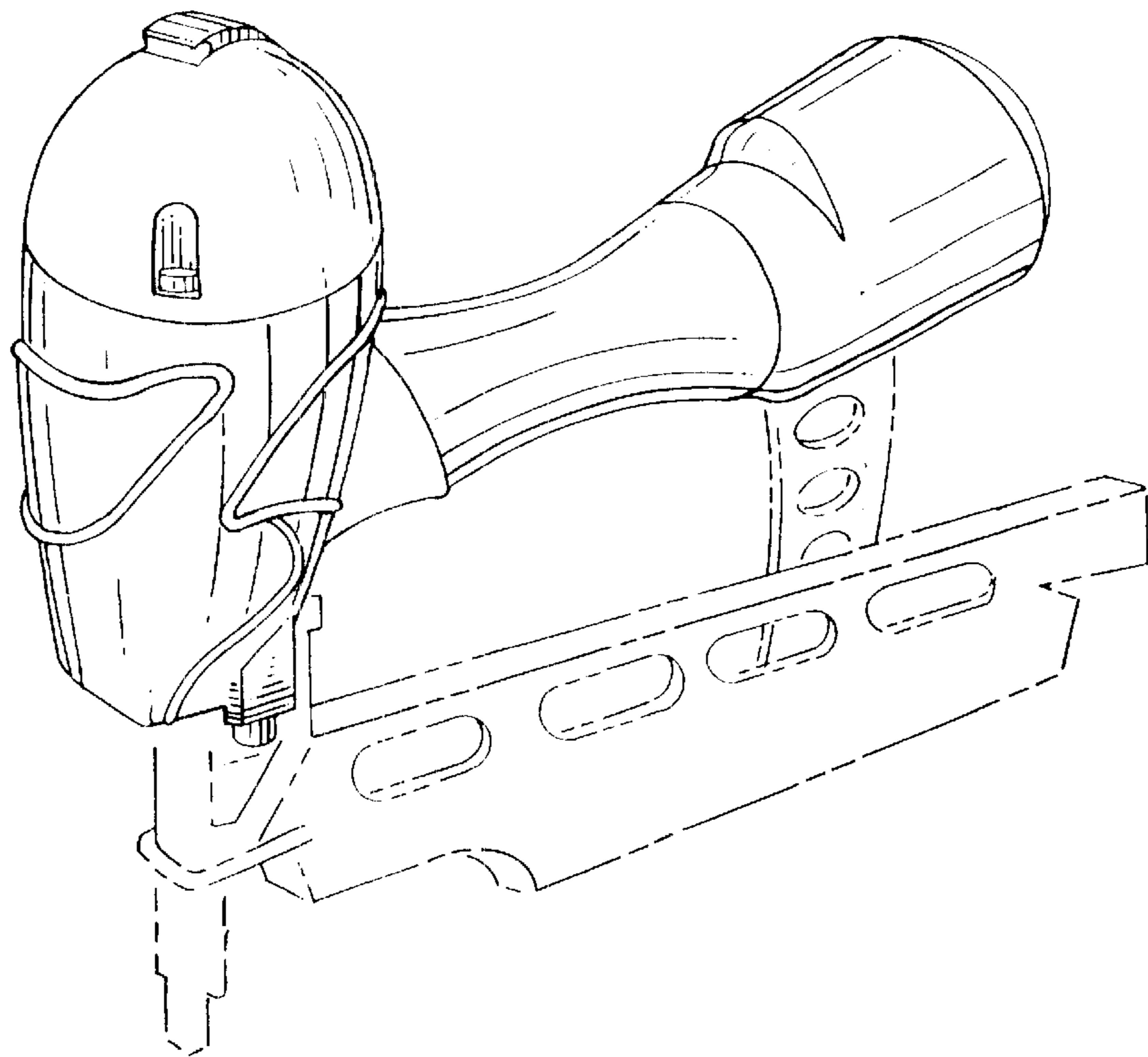

FIG. 2

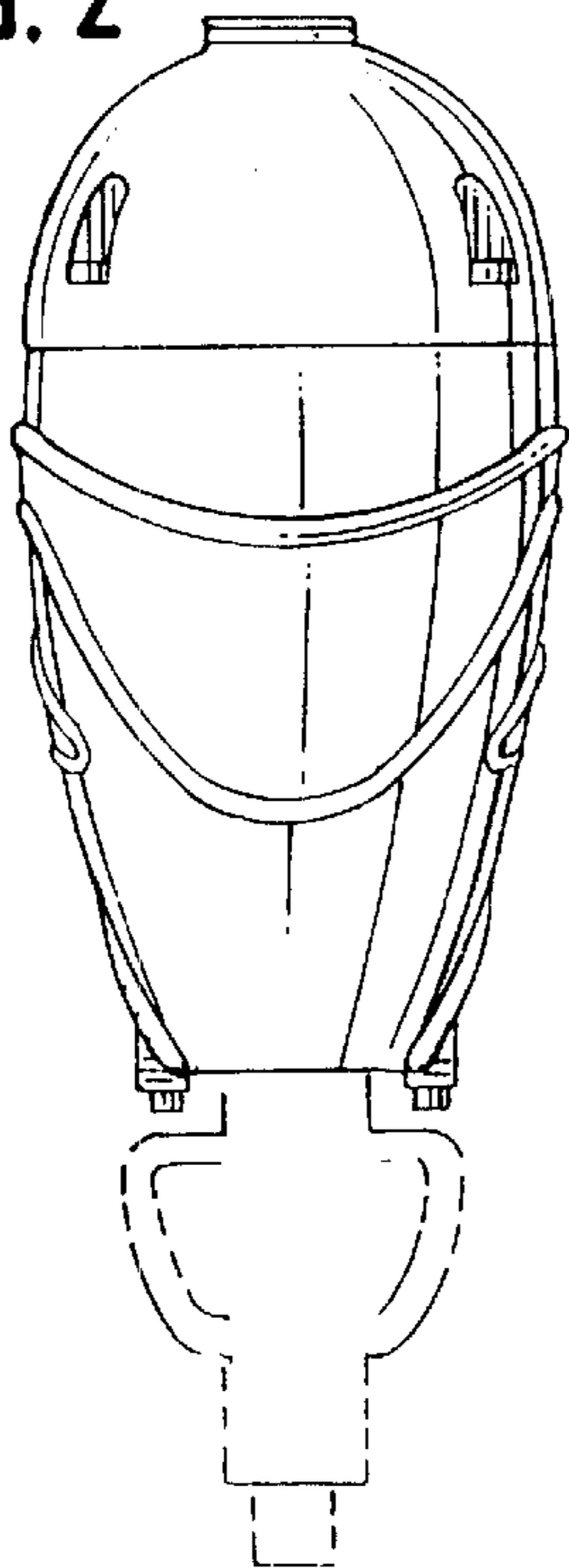

FIG. 3

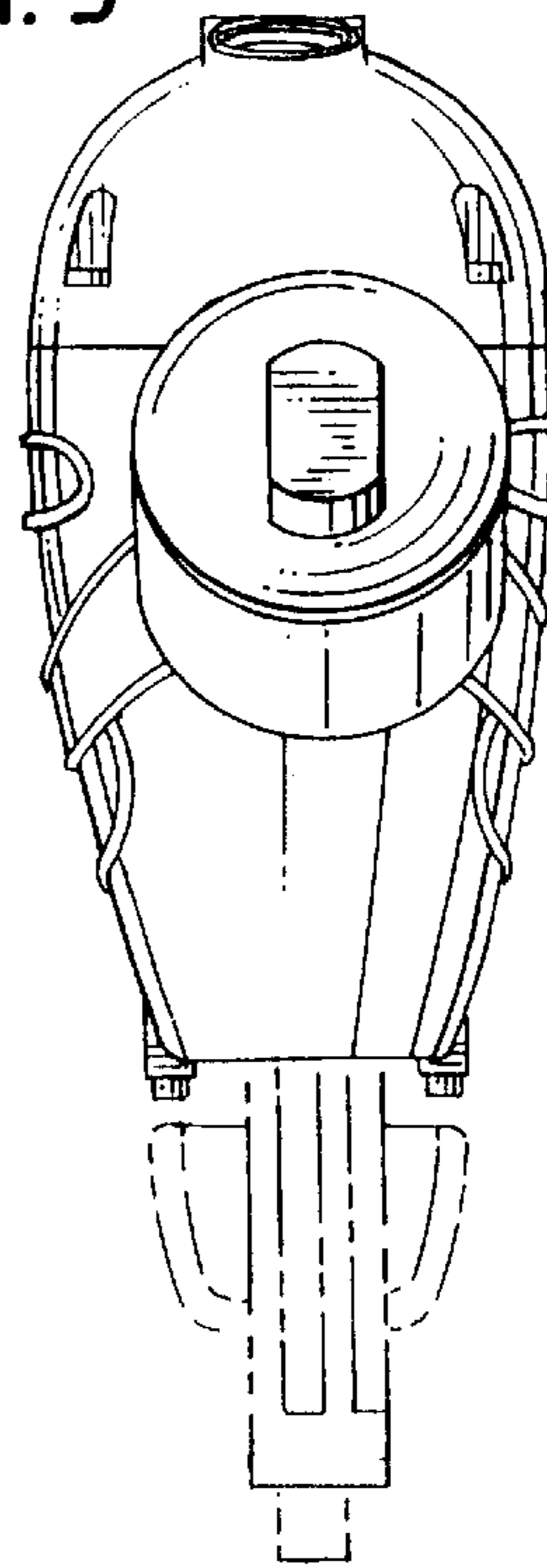

FIG. 4

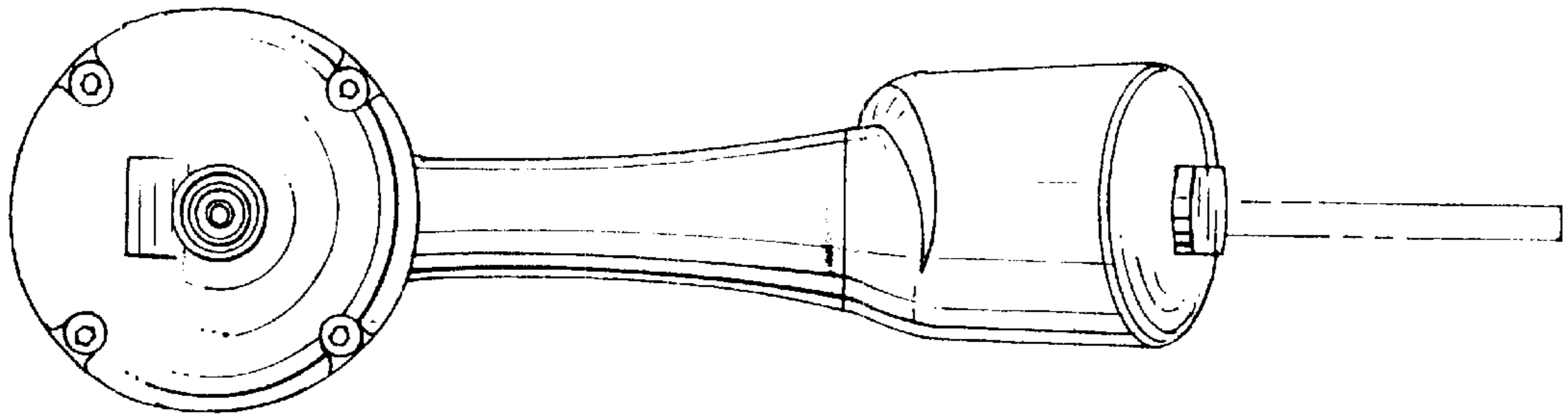

FIG. 5

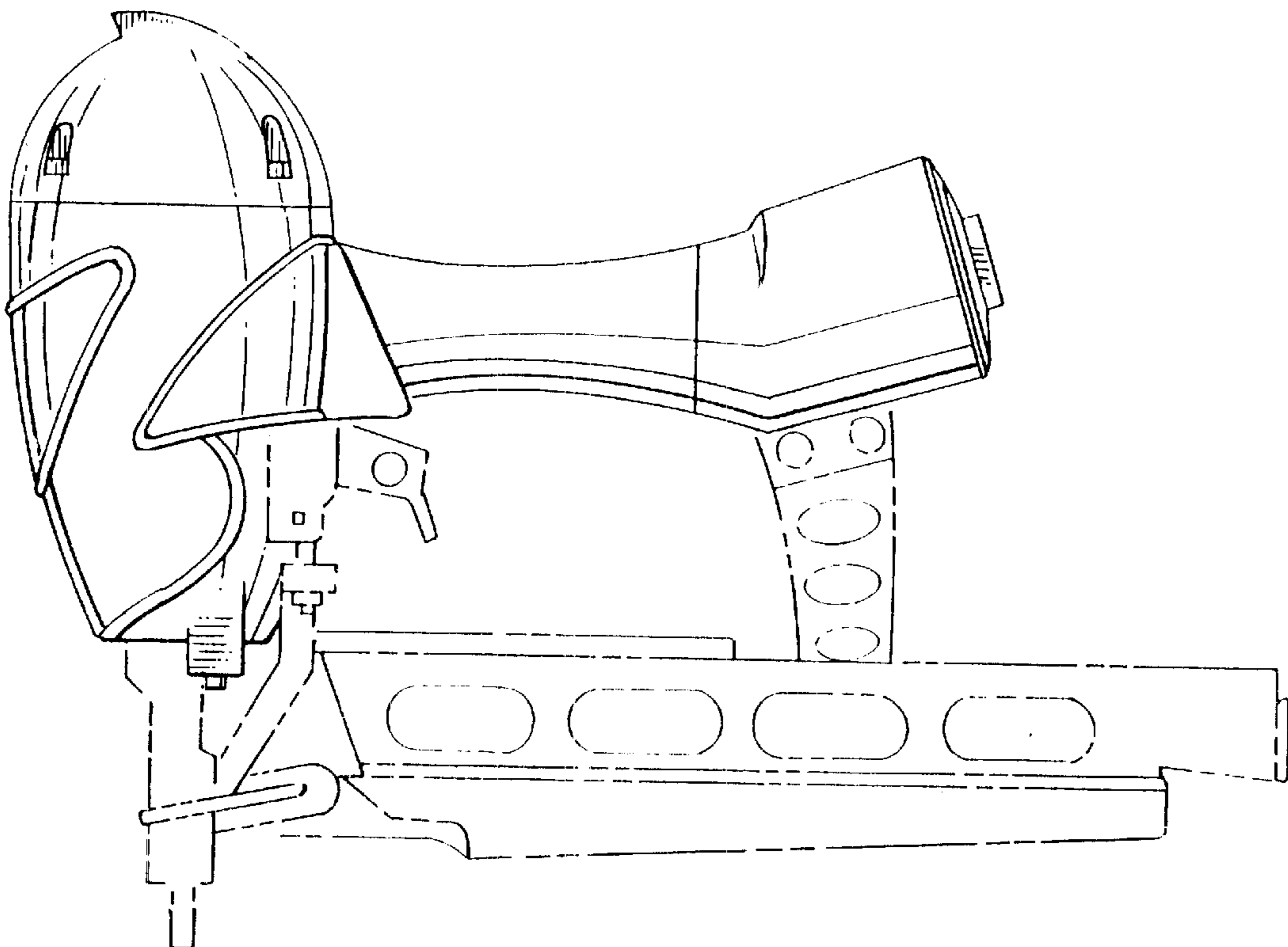

FIG. 6

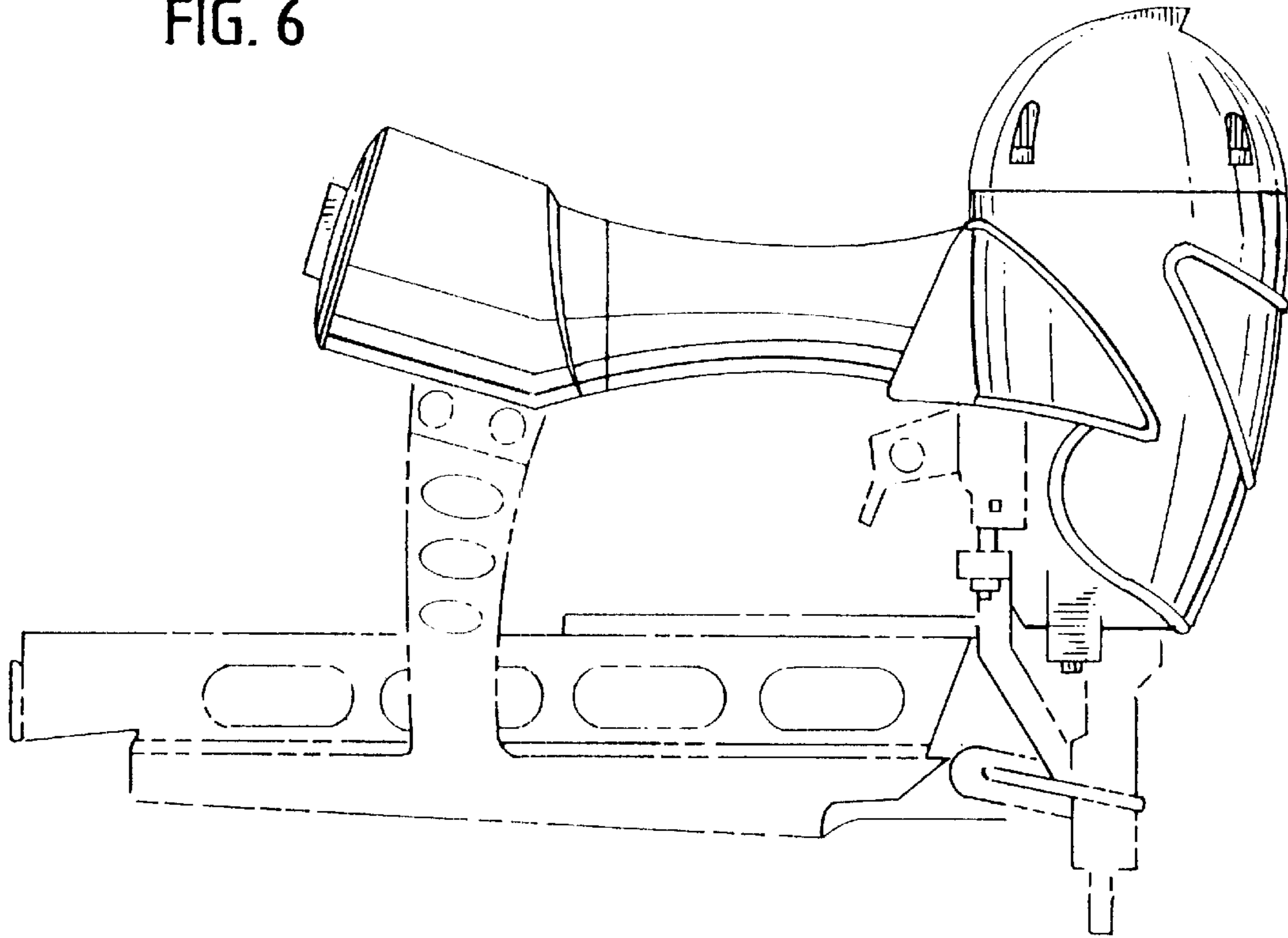

FIG. 7

