



US00D462937S

(12) **United States Design Patent**  
**Nord**

(10) **Patent No.:** **US D462,937 S**

(45) **Date of Patent:** **\*\* Sep. 17, 2002**

(54) **ELECTRIC MOTOR AND THE HOUSING THEREOF**

(75) Inventor: **Göran Nord**, Helsingborg (SE)

(73) Assignee: **Emotron AB**, Helsingborg (SE)

(\*\*) Term: **14 Years**

(21) Appl. No.: **29/124,164**

(22) Filed: **Jun. 1, 2000**

(30) **Foreign Application Priority Data**

Dec. 3, 1999 (SE) ..... 99-2196

(51) **LOC (7) Cl.** ..... **13-01**

(52) **U.S. Cl.** ..... **D13/112**

(58) **Field of Search** ..... D13/112; 310/40 R,  
310/52, 58, 89, 91

(56) **References Cited**

**U.S. PATENT DOCUMENTS**

- 3,983,429 A \* 9/1976 Allardice, Jr. .... 310/91
- D245,498 S \* 8/1977 Andreas ..... D13/112
- D278,334 S \* 4/1985 Watanabe ..... D14/199
- D298,228 S \* 10/1988 Hoshino ..... D13/112
- D304,169 S \* 10/1989 Hoshino et al. .... D13/112
- D306,009 S \* 2/1990 Mintz et al. .... D13/112
- D310,816 S \* 9/1990 Sawato et al. .... D13/112
- 5,406,156 A \* 4/1995 Somers ..... 310/89

\* cited by examiner

*Primary Examiner*—Joel Sincavage

(74) *Attorney, Agent, or Firm*—Browdy and Neimark

(57) **CLAIM**

The ornamental design for an electric motor and the housing thereof, as shown and described.

**DESCRIPTION**

FIG. 1 is a perspective view showing the front side, the right-hand side, and the upper side of an electric motor and the housing thereof according to the invention;

FIG. 2 is a perspective view showing the rear side, the right-hand side, and the bottom side thereof;

FIG. 3 is a front elevation view thereof;

FIG. 4 is a right side elevation view thereof;

FIG. 5 is a bottom plan view thereof;

FIG. 6 is a rear elevation view thereof;

FIG. 7 is a left side elevation view thereof;

FIG. 8 is a top plan view thereof;

FIG. 9 is a perspective view showing the front side, the right-hand side, and the upper side of a housing of the electric motor of FIGS. 1–8;

FIG. 10 is a perspective view showing the rear side, the right-hand side, and the bottom side thereof;

FIG. 11 is a front elevation view thereof;

FIG. 12 is a right side elevation view thereof;

FIG. 13 is a bottom plan view thereof;

FIG. 14 is a rear elevation view thereof;

FIG. 15 is a left side elevation view thereof; and,

FIG. 16 is a top plan view thereof.

The claimed design is directed to the appearance of the electric motor and the housing thereof. The housing for the electric motor is shown separately in FIGS. 9–16 for the purpose of clarifying design aspects of the assembled motor and the housing that are not be apparent from other views.

**1 Claim, 6 Drawing Sheets**

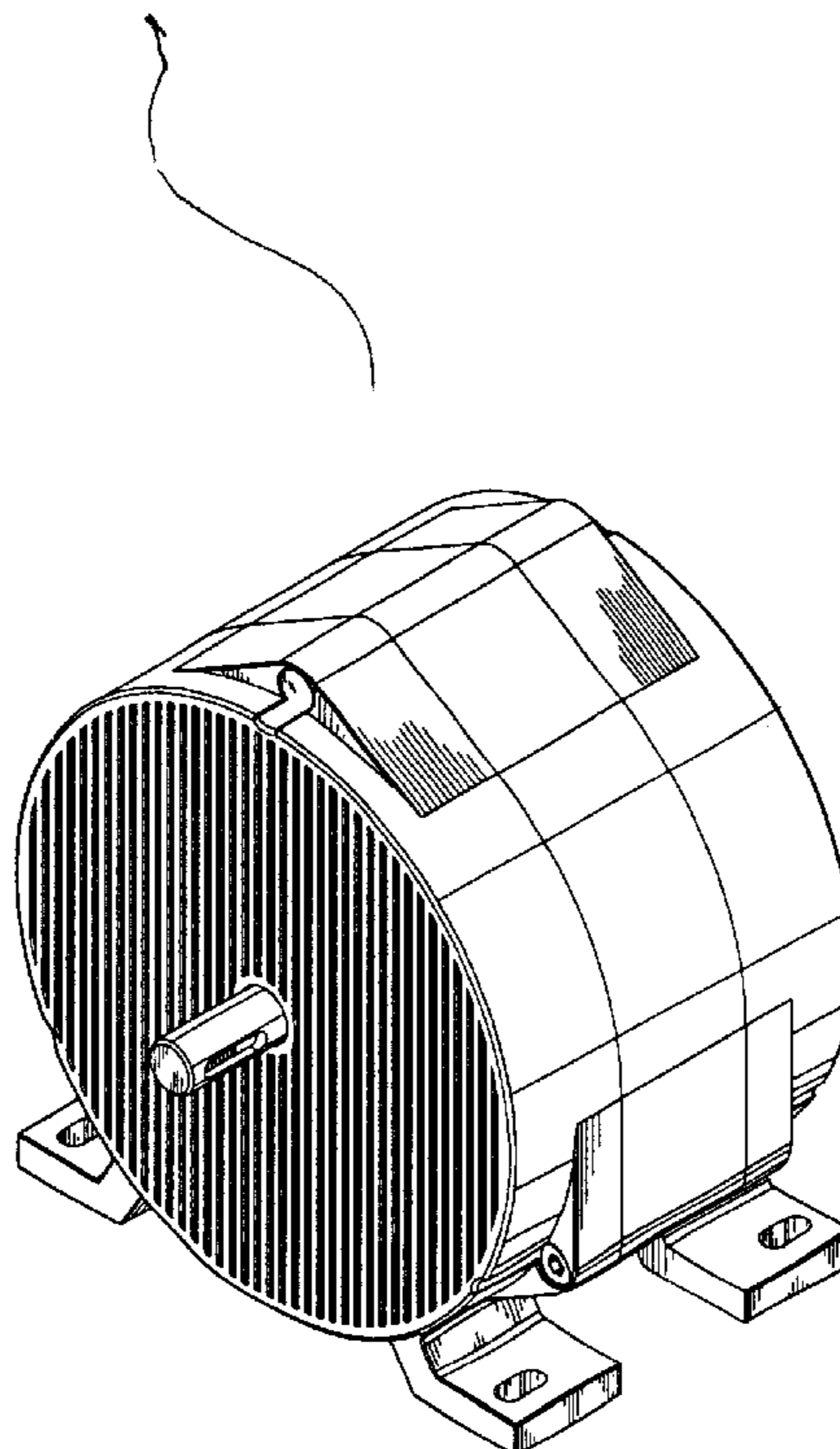

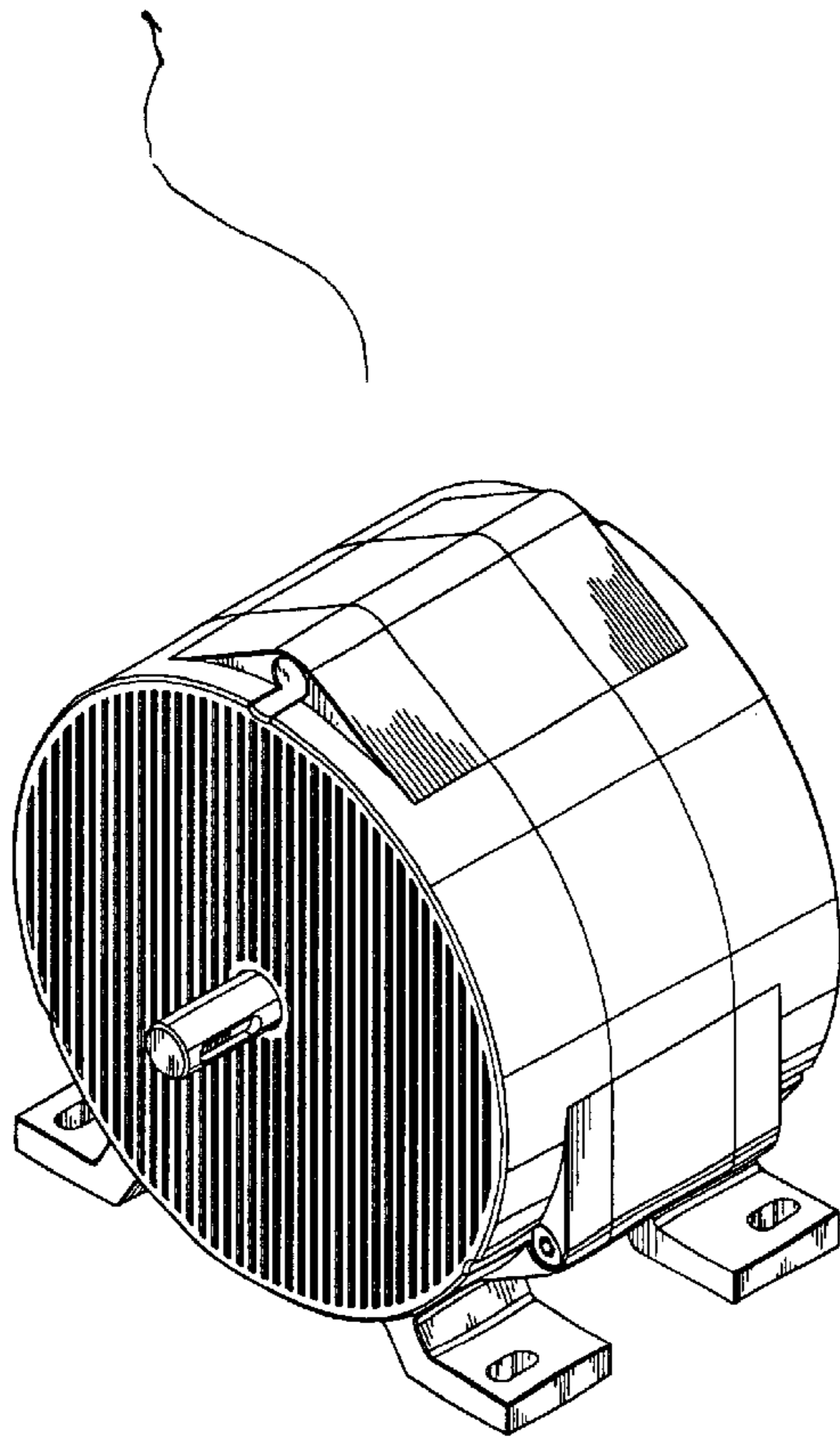

Figure 1

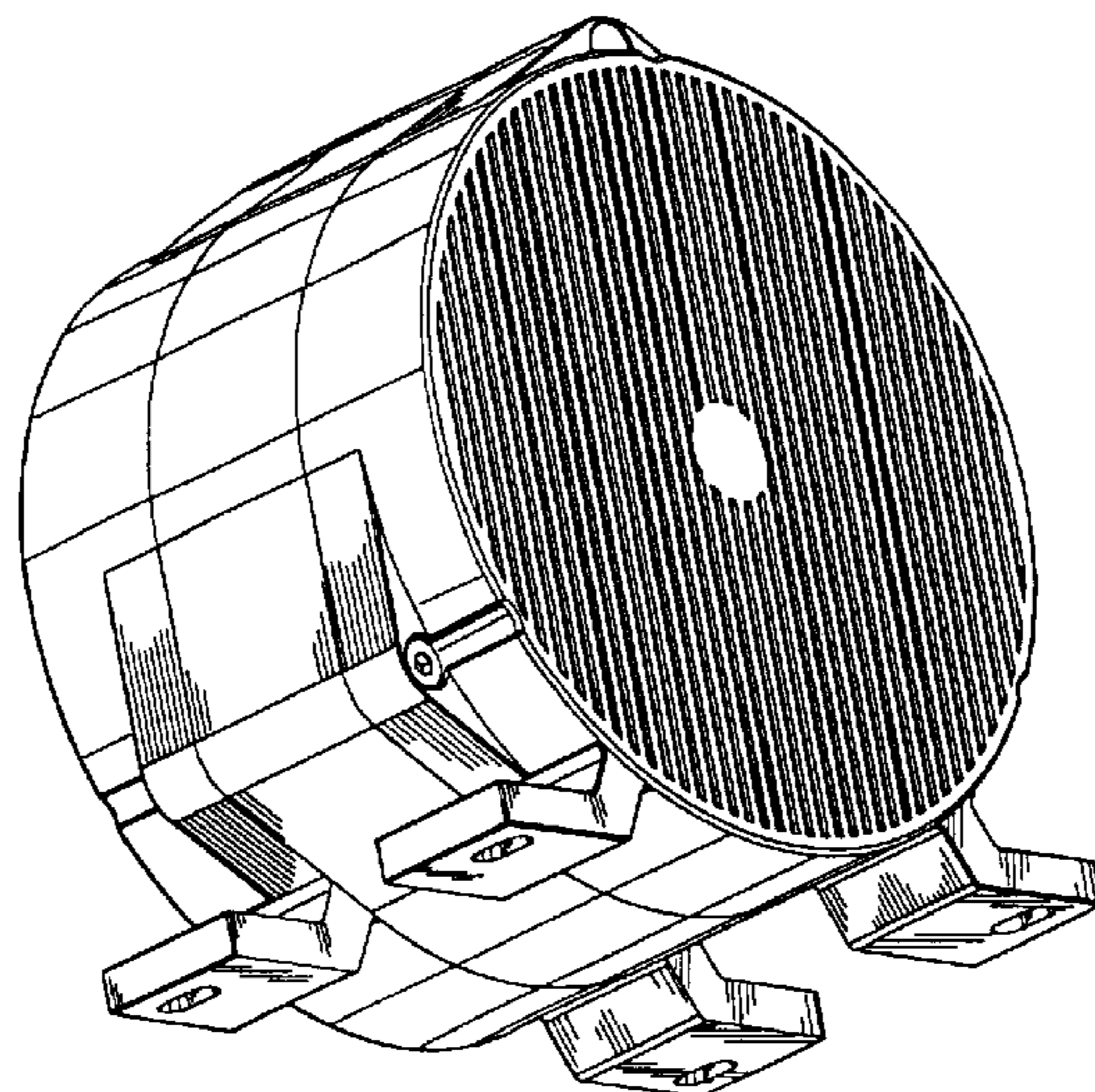

Figure 2

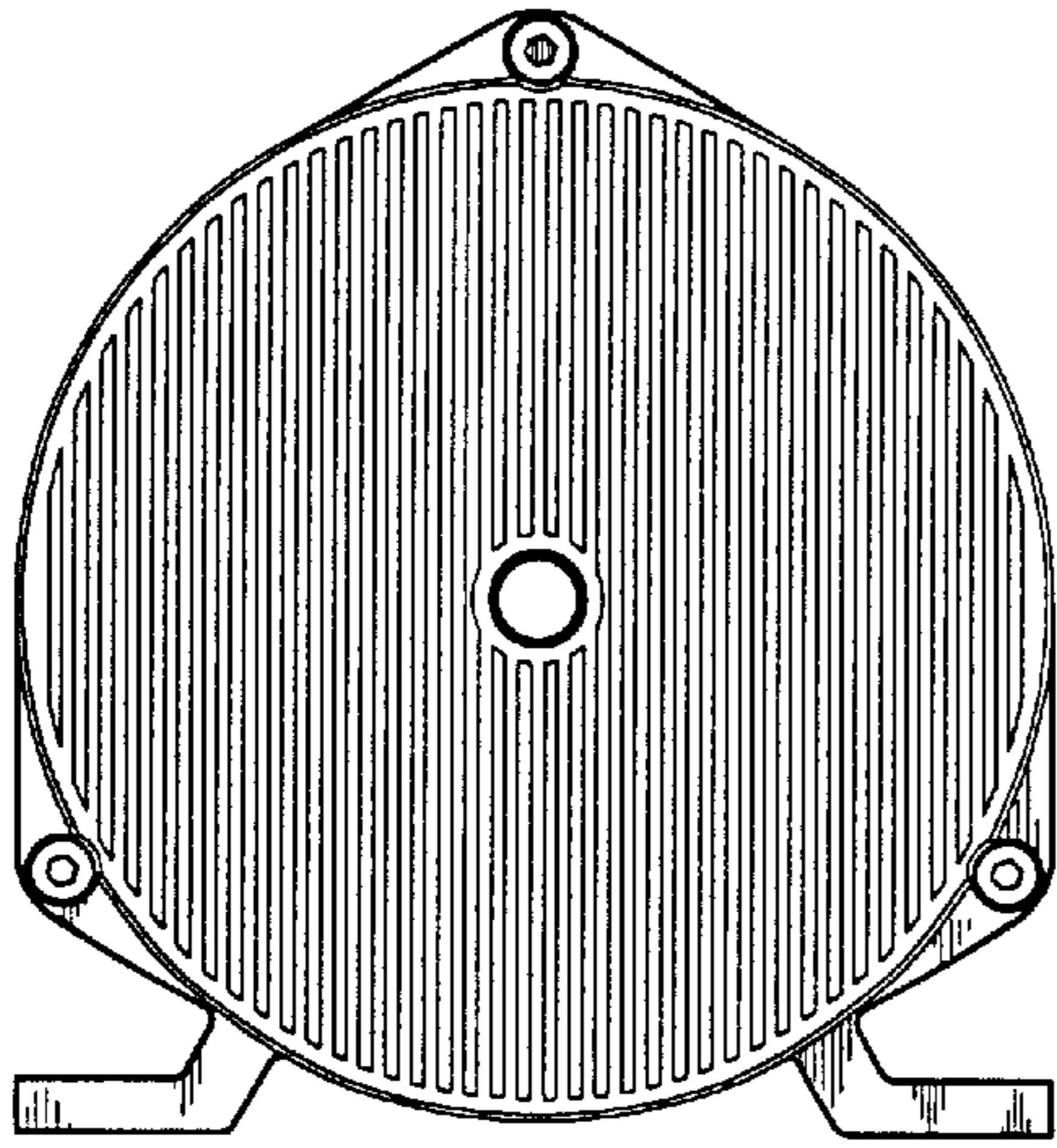

Figure 3

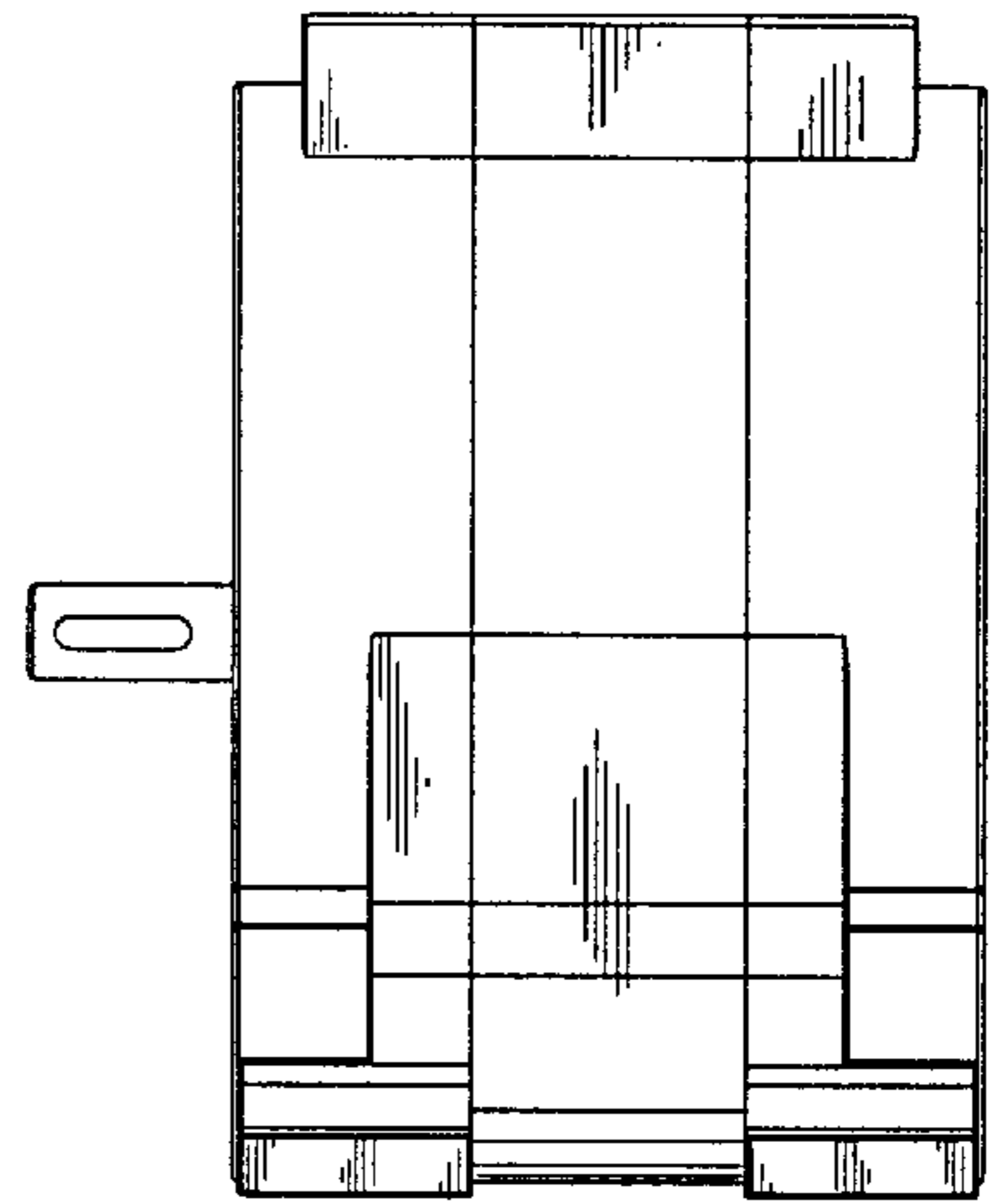

Figure 4

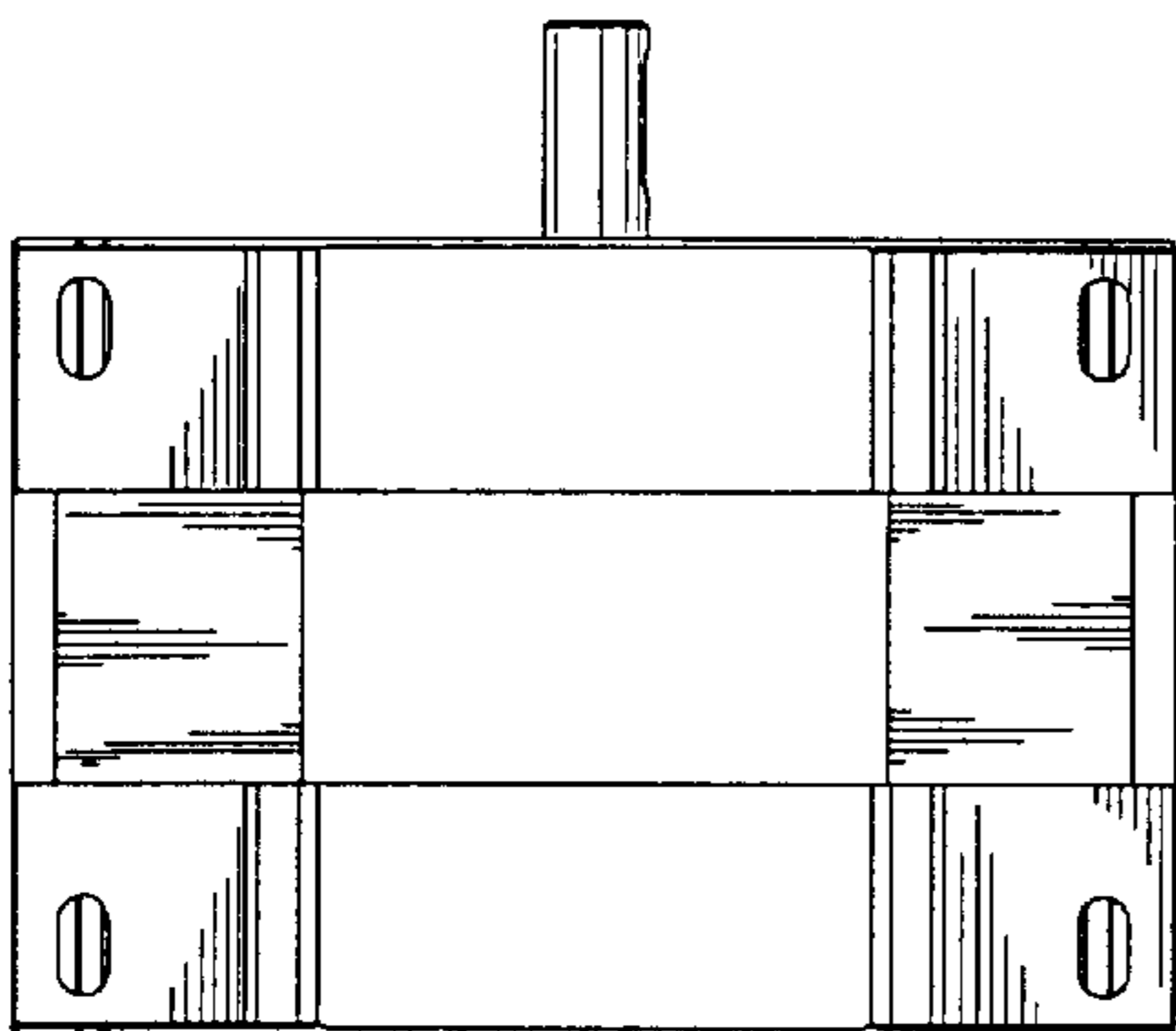
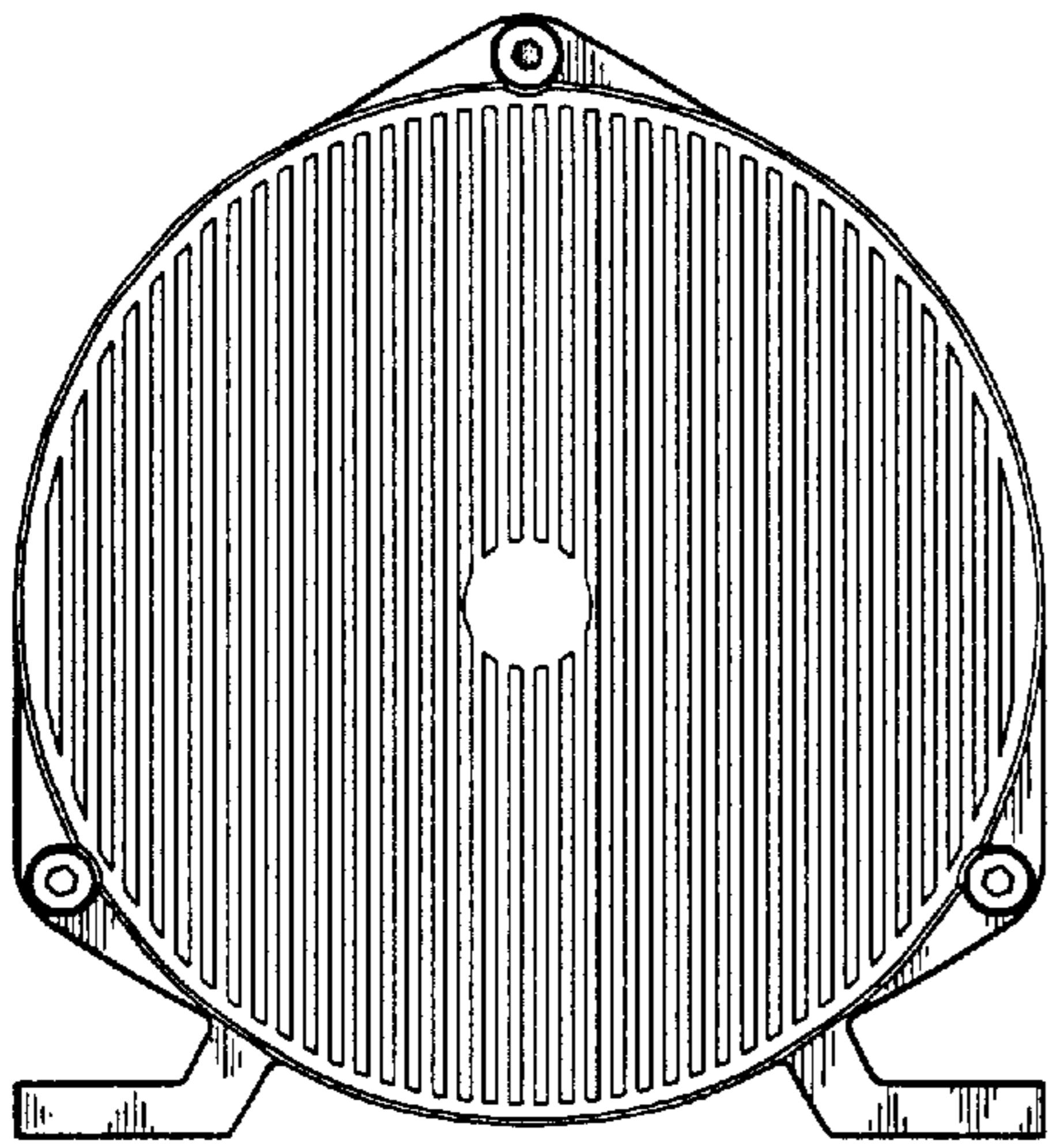
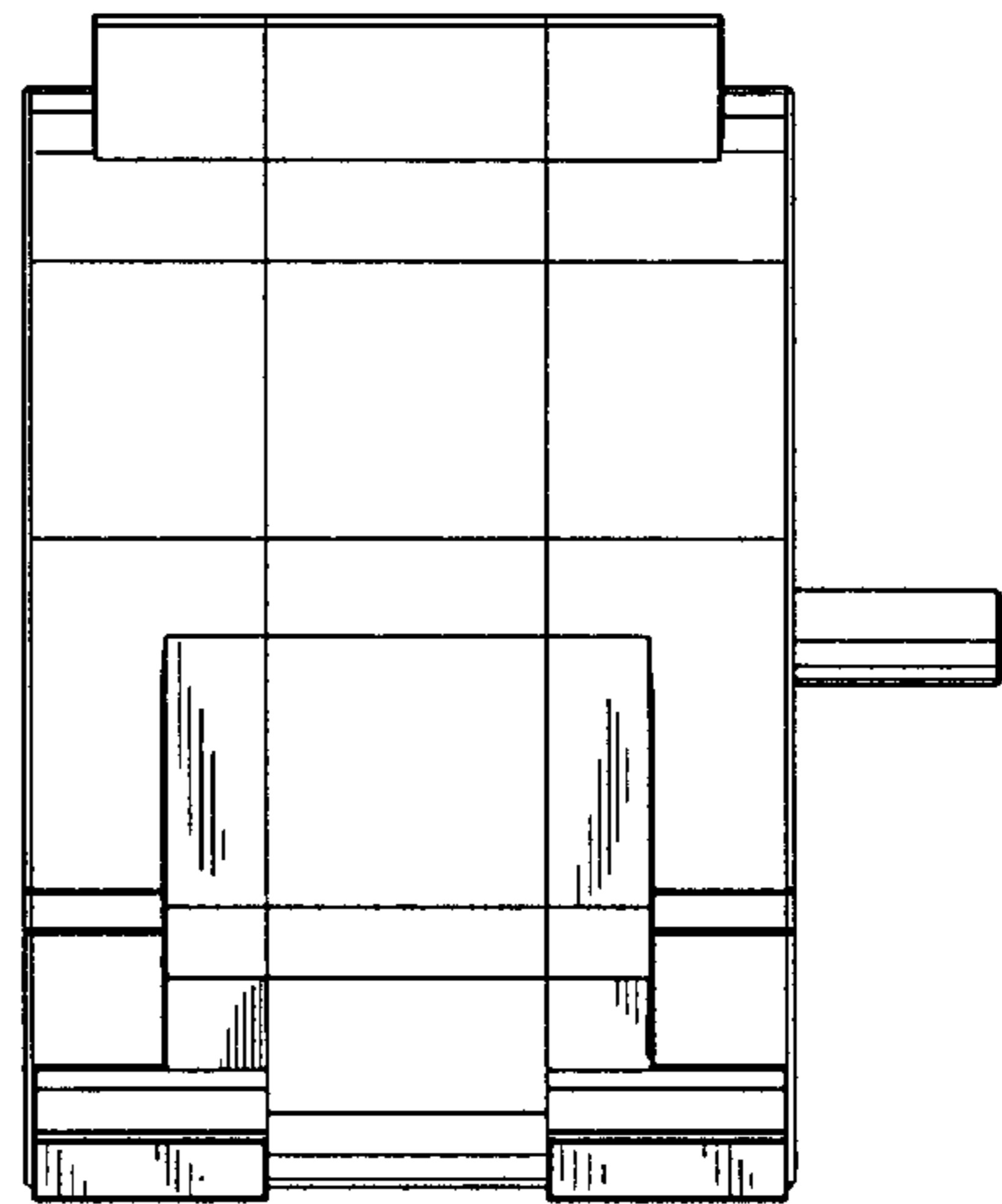

Figure 5



*Figure 6*



*Figure 7*

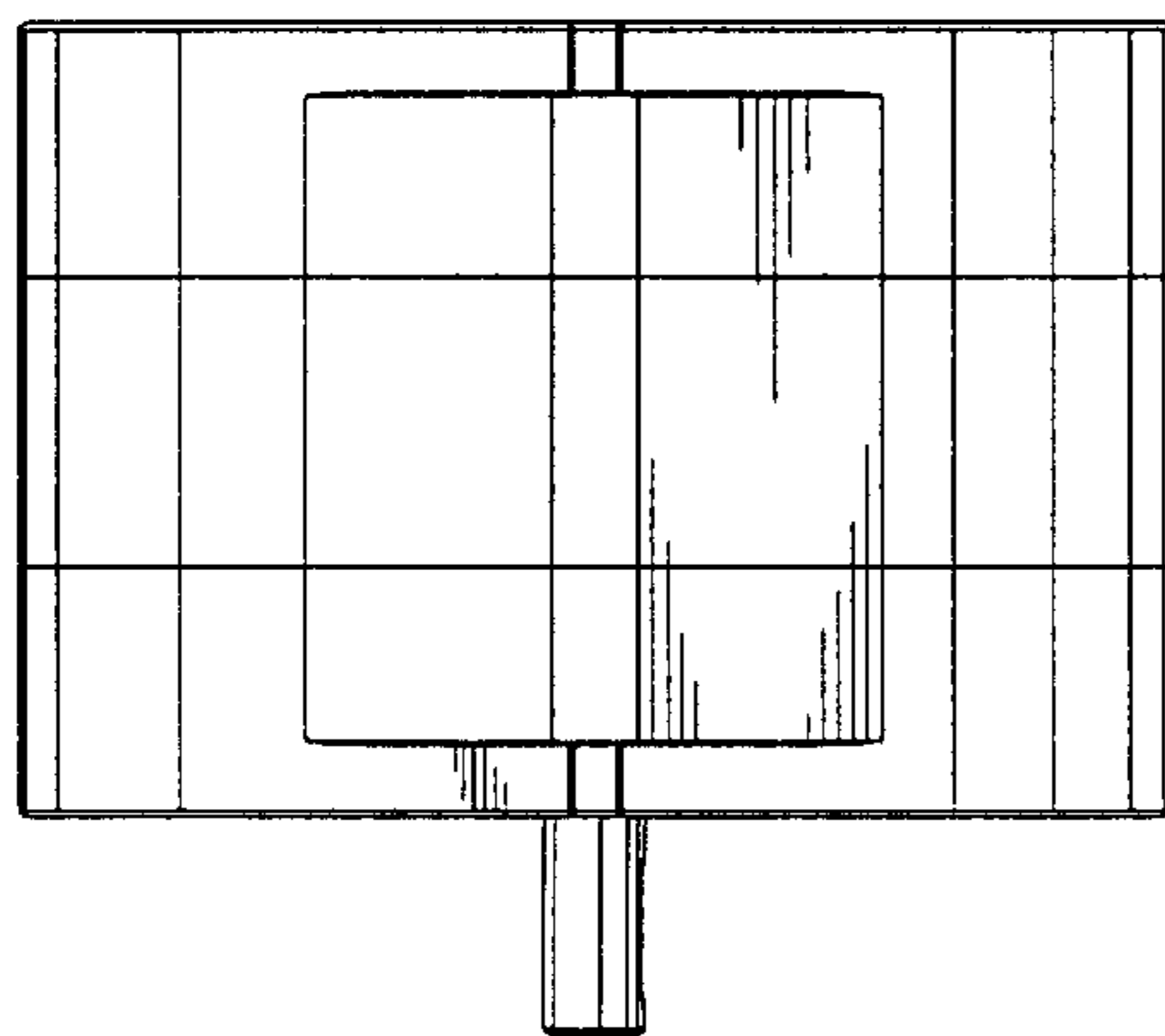

*Figure 8*

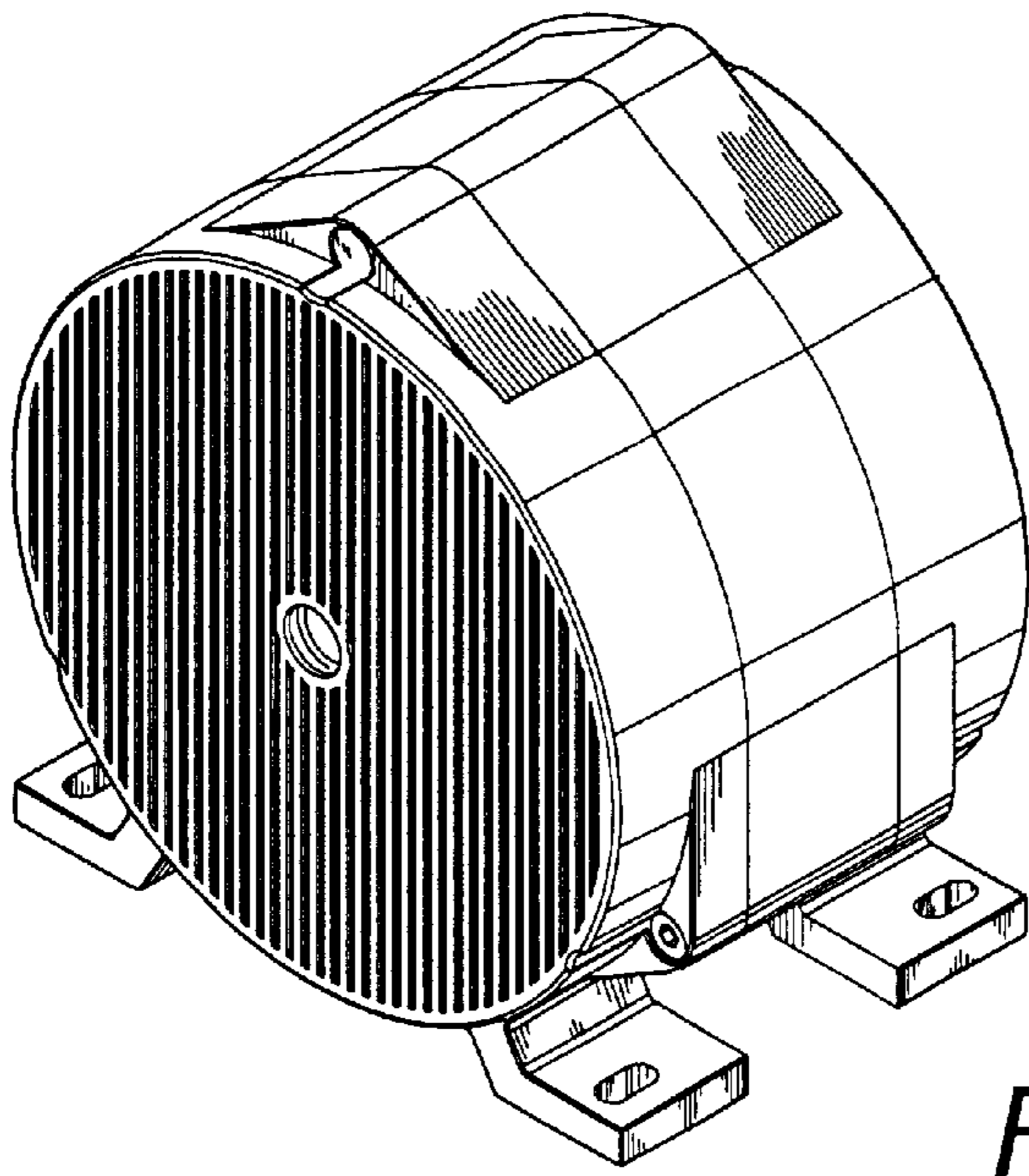

*Figure 9*

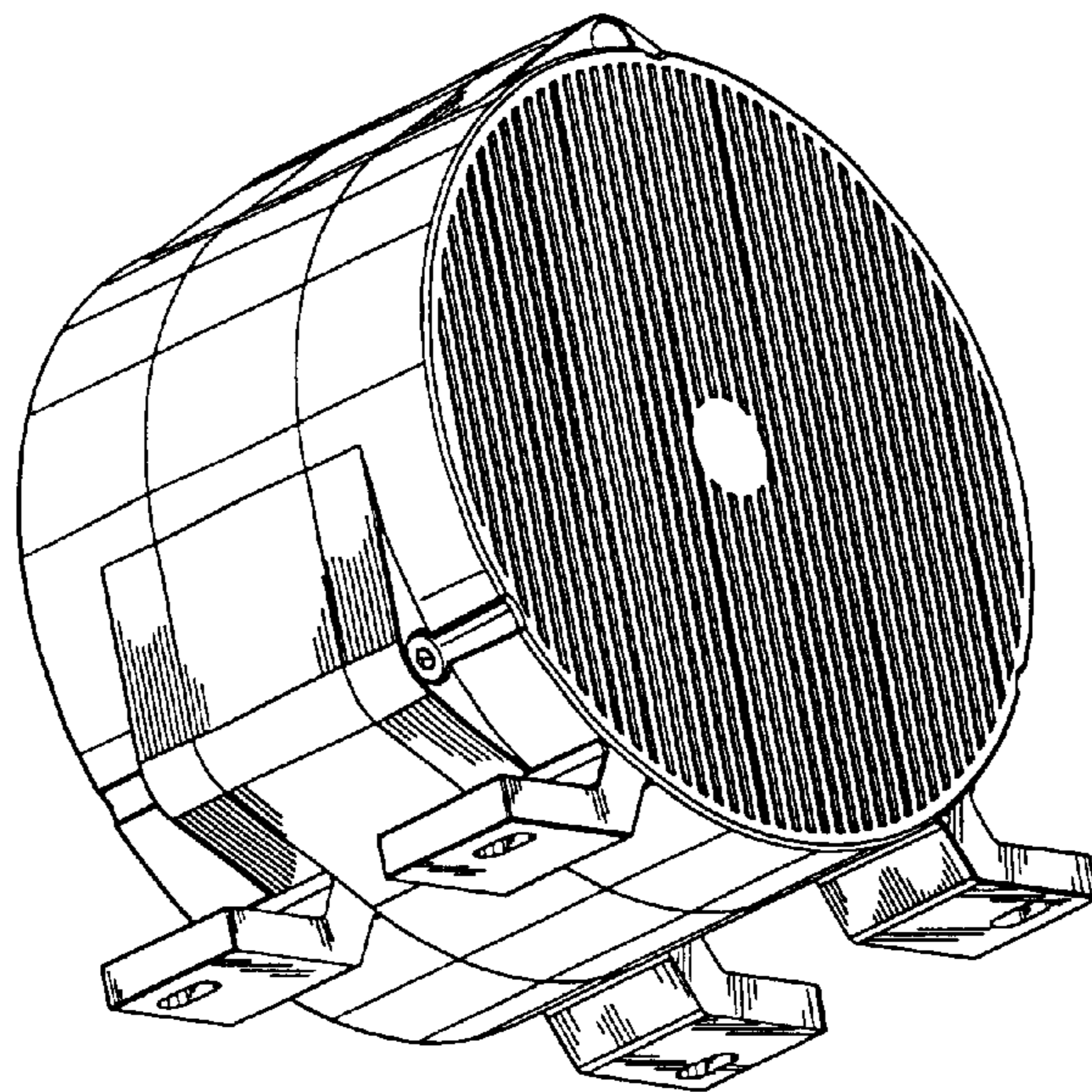

*Figure 10*

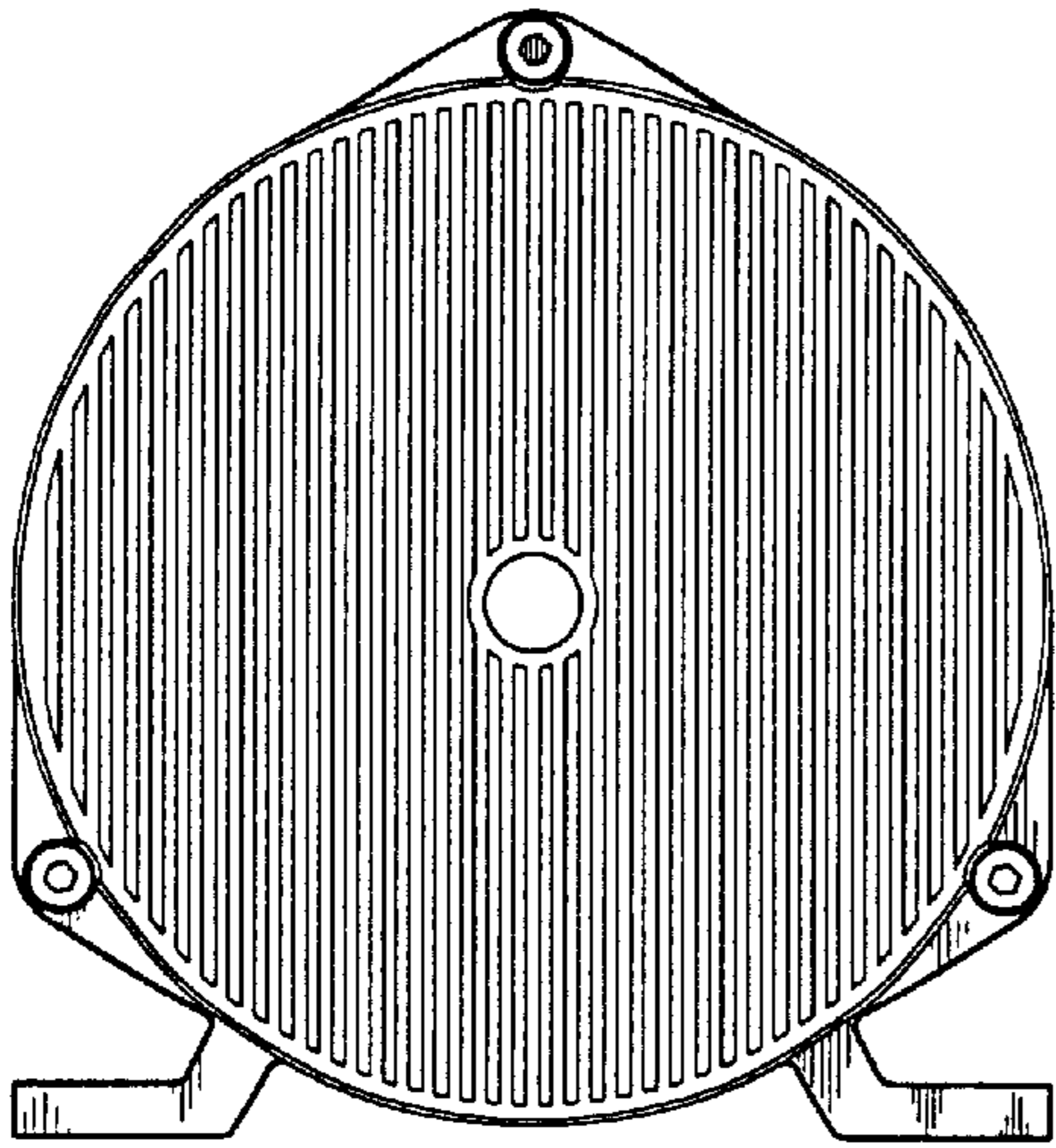

Figure 11

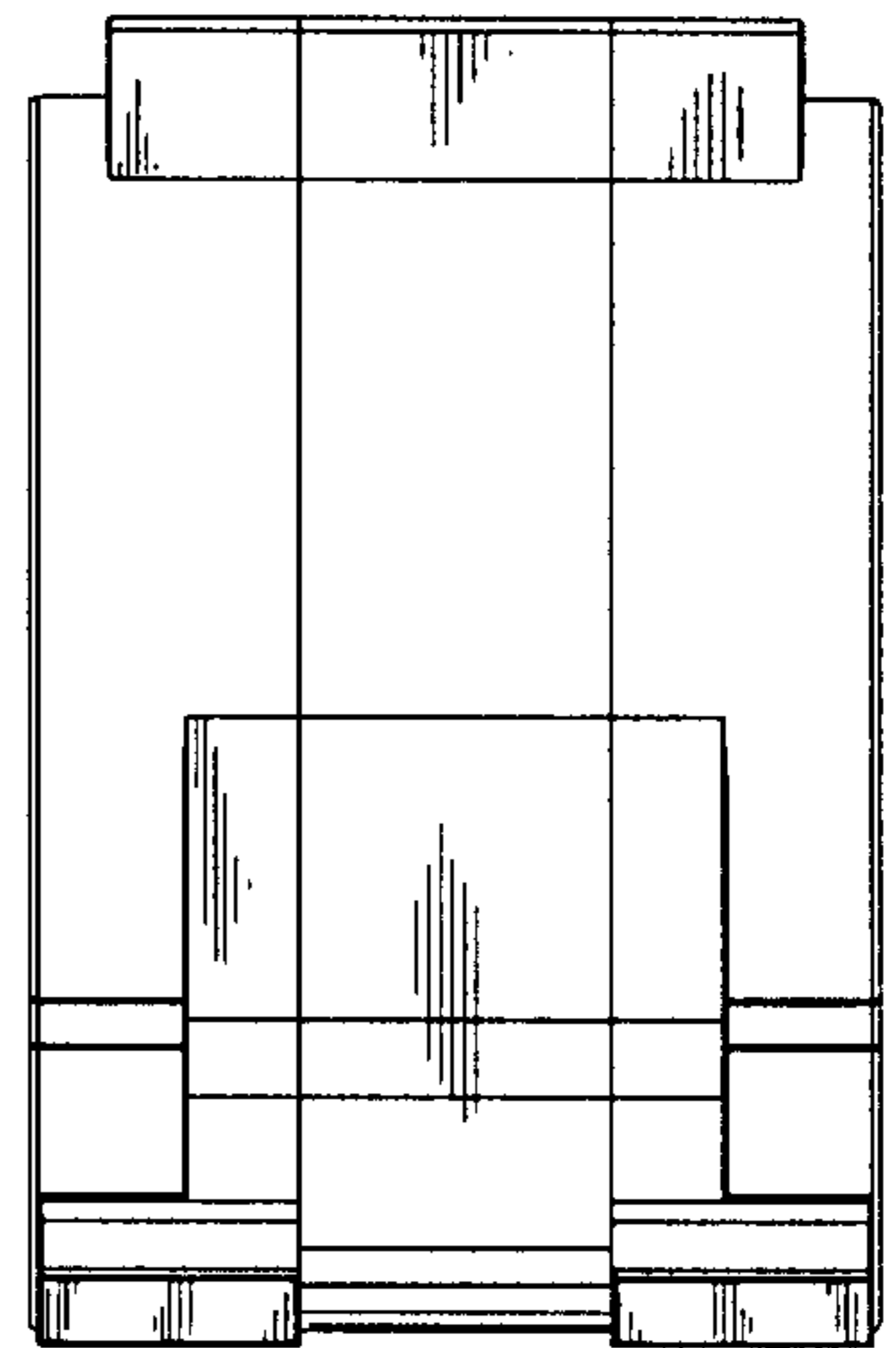

Figure 12

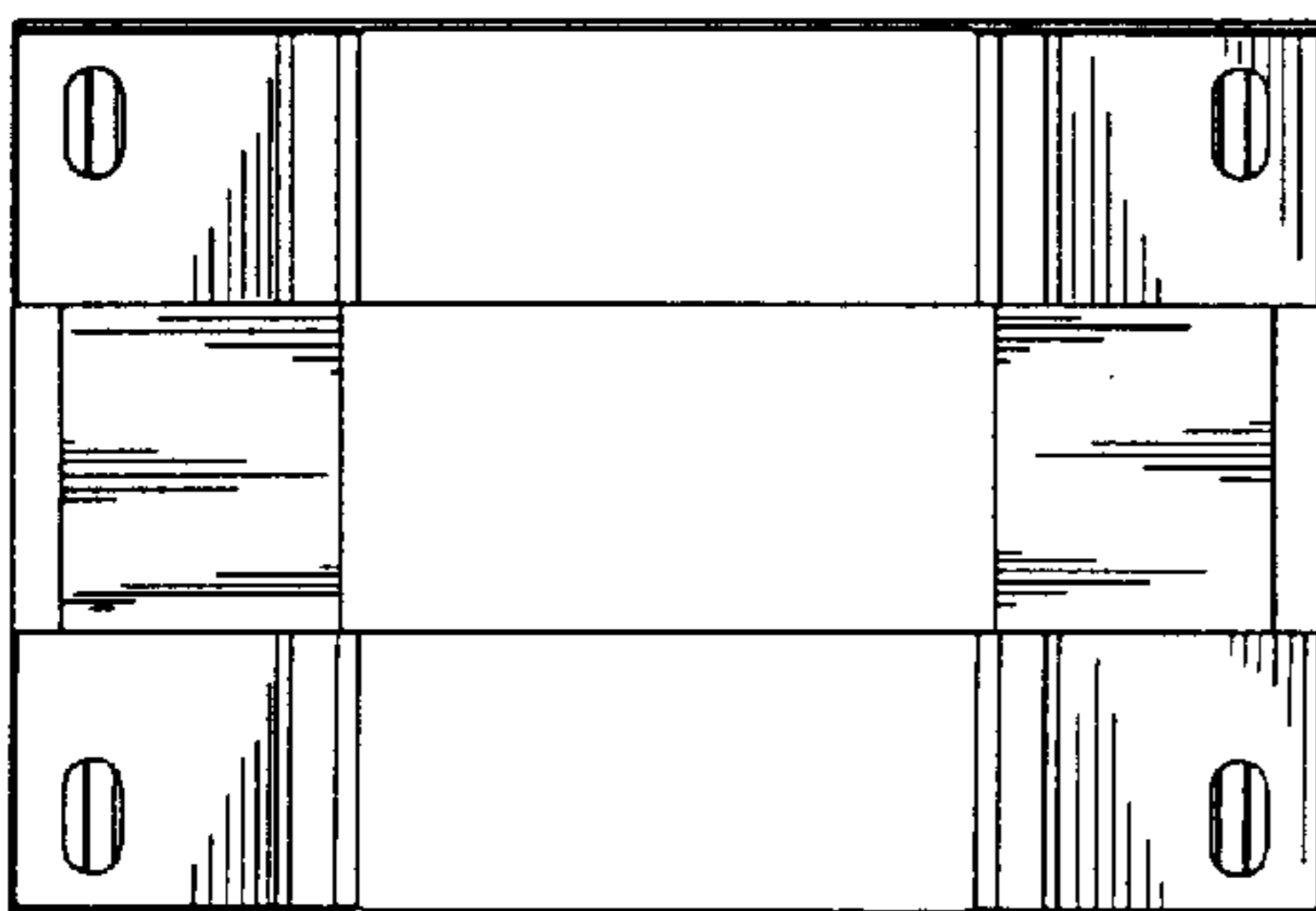

Figure 13

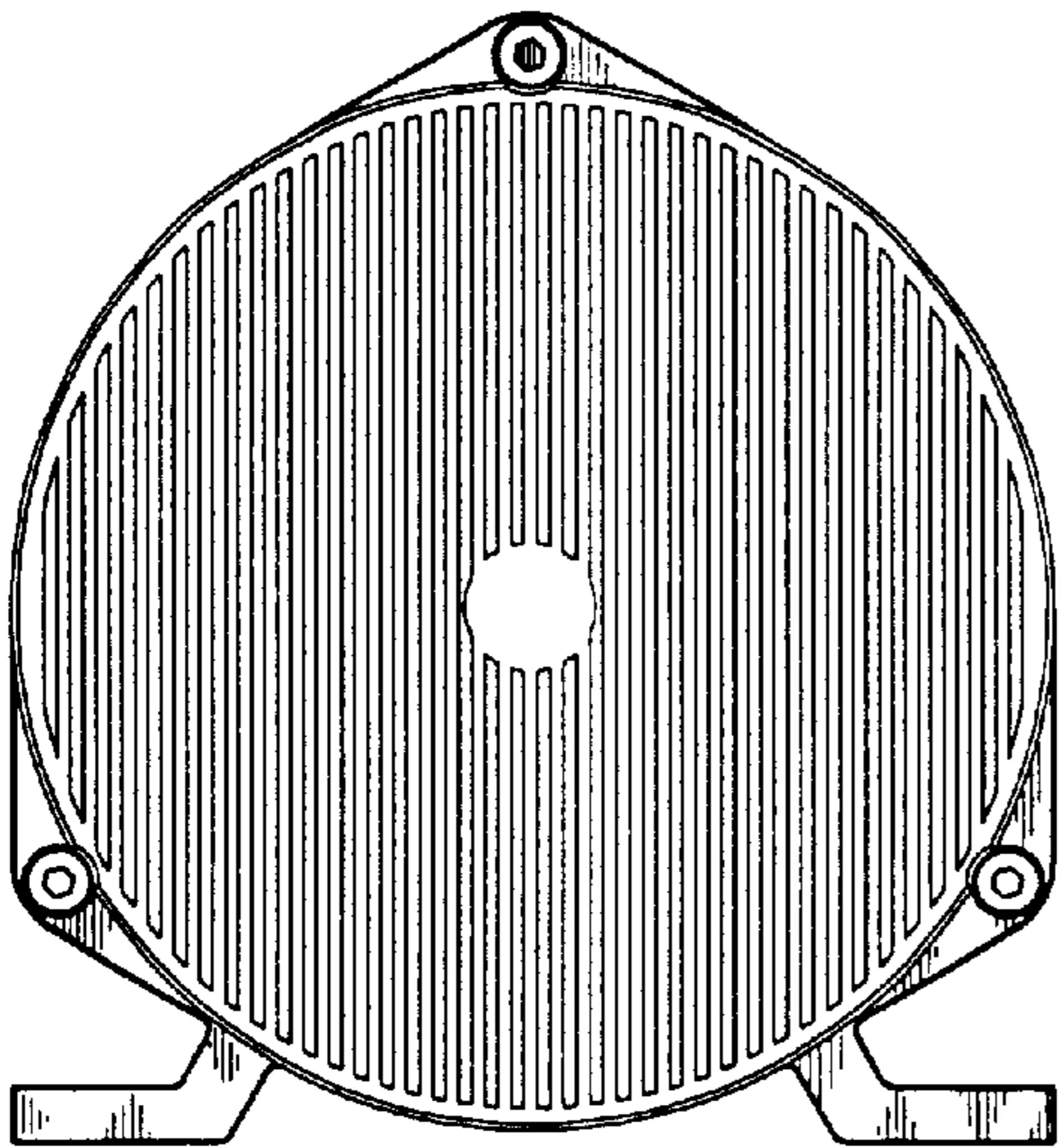

Figure 14

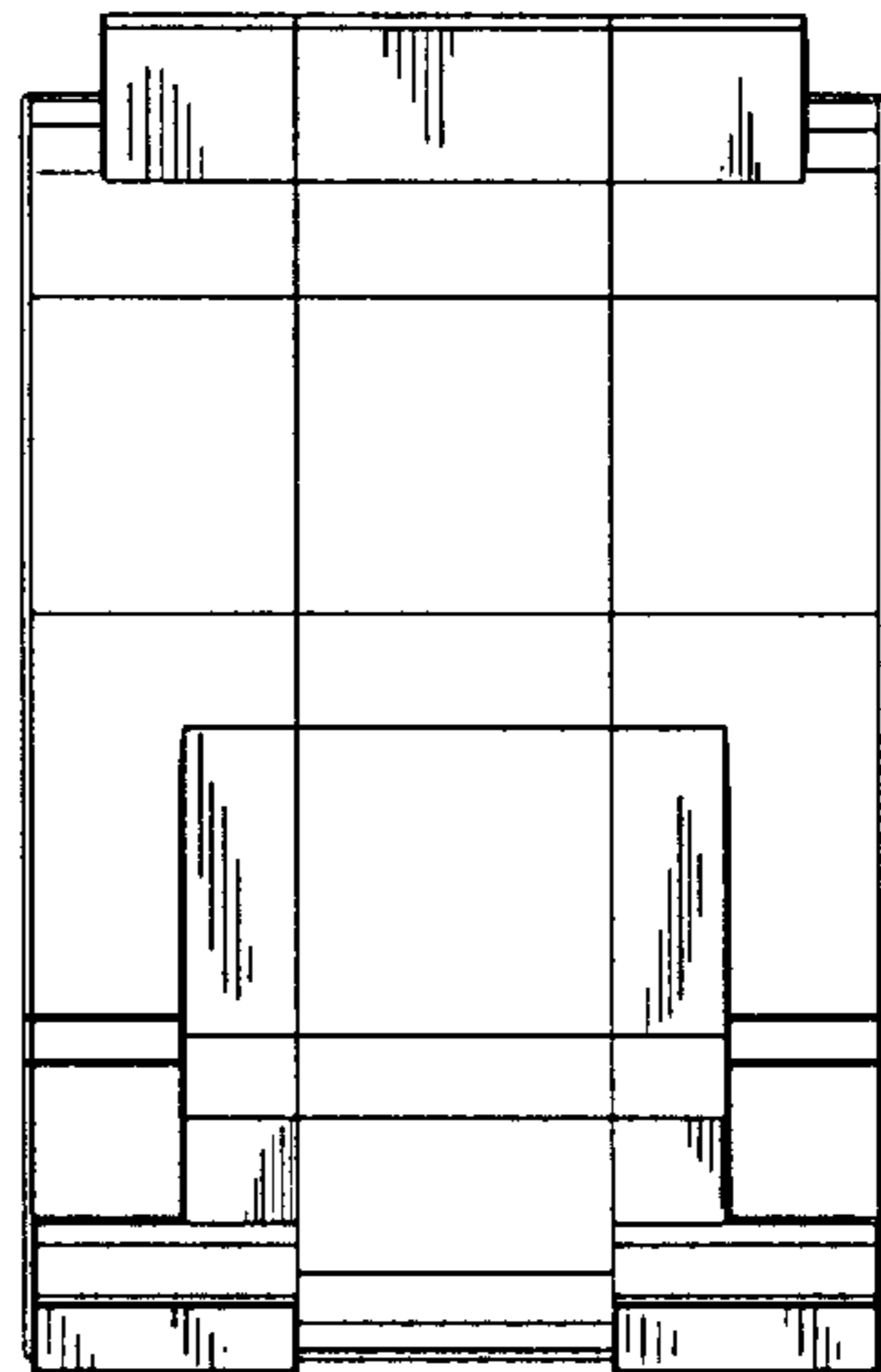

Figure 15

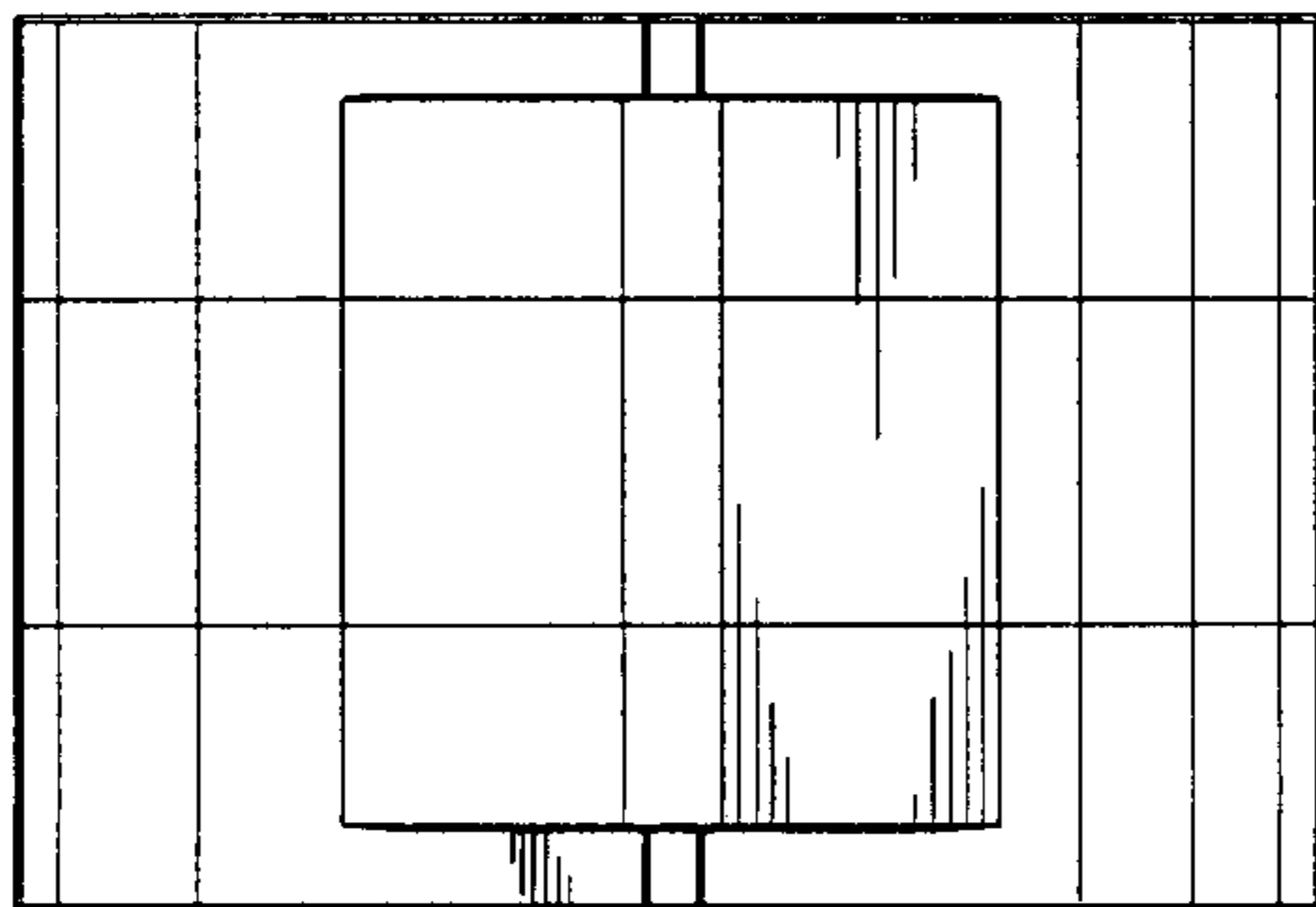

Figure 16