



US00D462932S

(12) **United States Design Patent**
Larson

(10) **Patent No.:** **US D462,932 S**

(45) **Date of Patent:** **** Sep. 17, 2002**

(54) **WATER SPORTS TOWING DEVICE**

(75) Inventor: **Borden Larson**, Orlando, FL (US)

(73) Assignee: **Correct Craft, Inc.**, Orlando, FL (US)

(**) Term: **14 Years**

(21) Appl. No.: **29/141,472**

(22) Filed: **May 7, 2001**

Related U.S. Application Data

(60) Division of application No. 09/624,166, filed on Jul. 24, 2000, which is a continuation of application No. 09/399,683, filed on Sep. 21, 1999, now Pat. No. 6,192,819, which is a continuation-in-part of application No. 09/036,826, filed on Mar. 9, 1998, now Pat. No. 5,979,350.

(51) **LOC (7) Cl.** **12-06**

(52) **U.S. Cl.** **D12/317**

(58) **Field of Search** D12/300-318;
114/343, 210, 251

(56) **References Cited**

U.S. PATENT DOCUMENTS

D195,068 S * 4/1963 Griparis D12/317

3,503,358 A * 3/1970 Moesly 114/125

D298,311 S * 11/1988 Greenberg D12/317

* cited by examiner

Primary Examiner—Lisa Lichtenstein

(74) *Attorney, Agent, or Firm*—Allen, Dyer, Doppelt, Milbrath & Gilchrist, P.A.

(57) **CLAIM**

The ornamental design for a water sports towing device, as shown and described.

DESCRIPTION

FIG. 1 is a left and front perspective view of a water sports towing device showing a new design;

FIG. 2 is a left elevation view thereof;
FIG. 3 is a bottom plan view thereof;
FIG. 4 is a right elevation view thereof;
FIG. 5 is a top plan view thereof;
FIG. 6 is a front elevation view thereof;
FIG. 7 is a rear elevation view thereof;
FIG. 8 is a left and front perspective view of a second embodiment thereof;
FIG. 9 is a left elevation view of FIG. 8;
FIG. 10 is a bottom plan view of FIG. 8;
FIG. 11 is a right elevation view of FIG. 8;
FIG. 12 is a top plan view of FIG. 8;
FIG. 13 is a front elevation view of FIG. 8;
FIG. 14 is a rear elevation view of FIG. 8;
FIG. 15 is a left and front perspective view of a third embodiment thereof;
FIG. 16 is a left elevation view of FIG. 15;
FIG. 17 is a bottom plan view of FIG. 15;
FIG. 18 is a right elevation view of FIG. 15;
FIG. 19 is a top plan view of FIG. 15;
FIG. 20 is a front elevation view of FIG. 15;
FIG. 21 is a rear elevation view of FIG. 15;
FIG. 22 is a left and front perspective view of a fourth embodiment thereof;
FIG. 23 is a left elevation view of FIG. 22;
FIG. 24 is a bottom plan view of FIG. 22;
FIG. 25 is a right elevation view of FIG. 22;
FIG. 26 is a top plan view of FIG. 22;
FIG. 27 is a front elevation view of FIG. 22; and,
FIG. 28 is a rear elevation view of FIG. 22.

The broken line showings in FIGS. 2, 8-14, 16 and 22-28 are for illustrative purposes only and form no part on the claimed design.

1 Claim, 8 Drawing Sheets

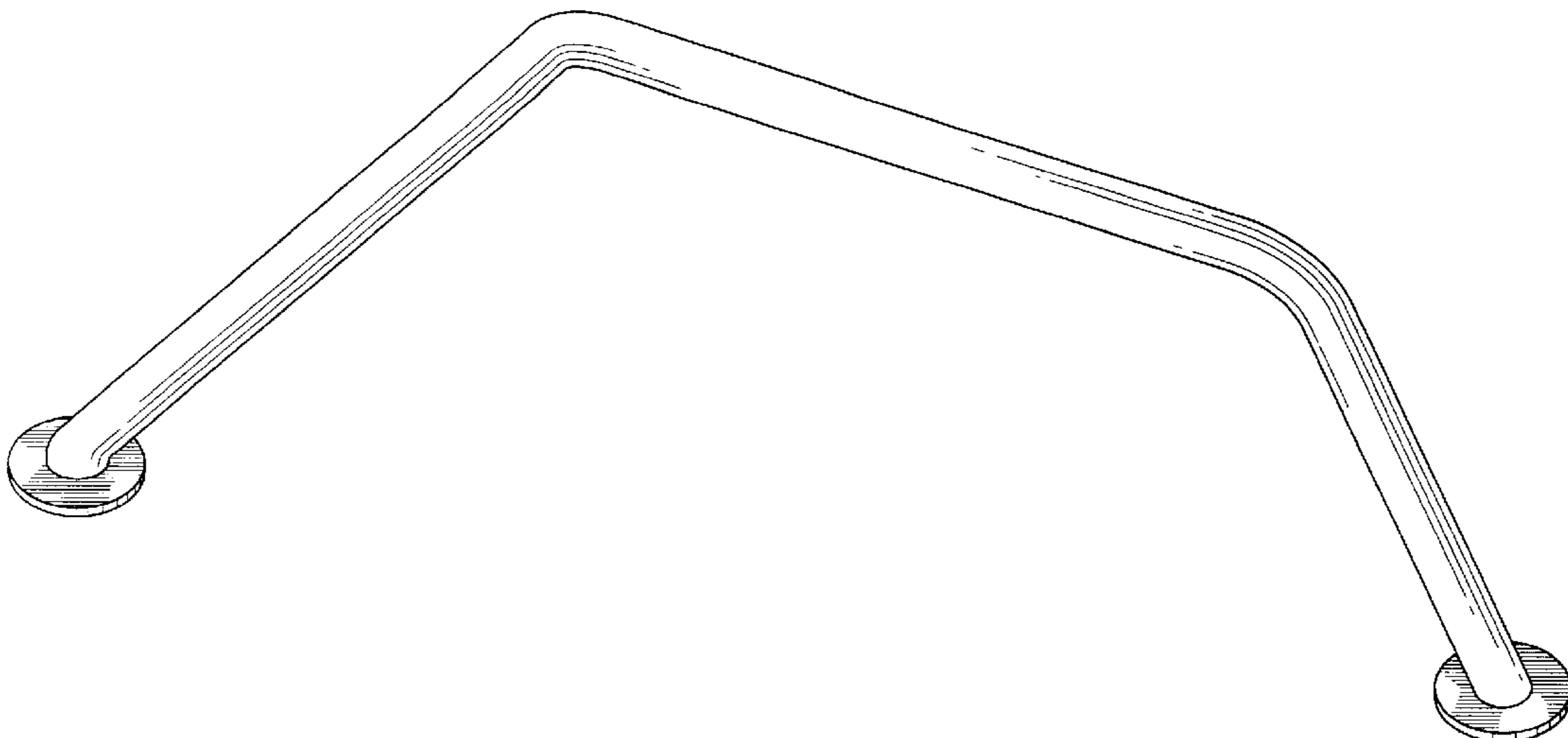

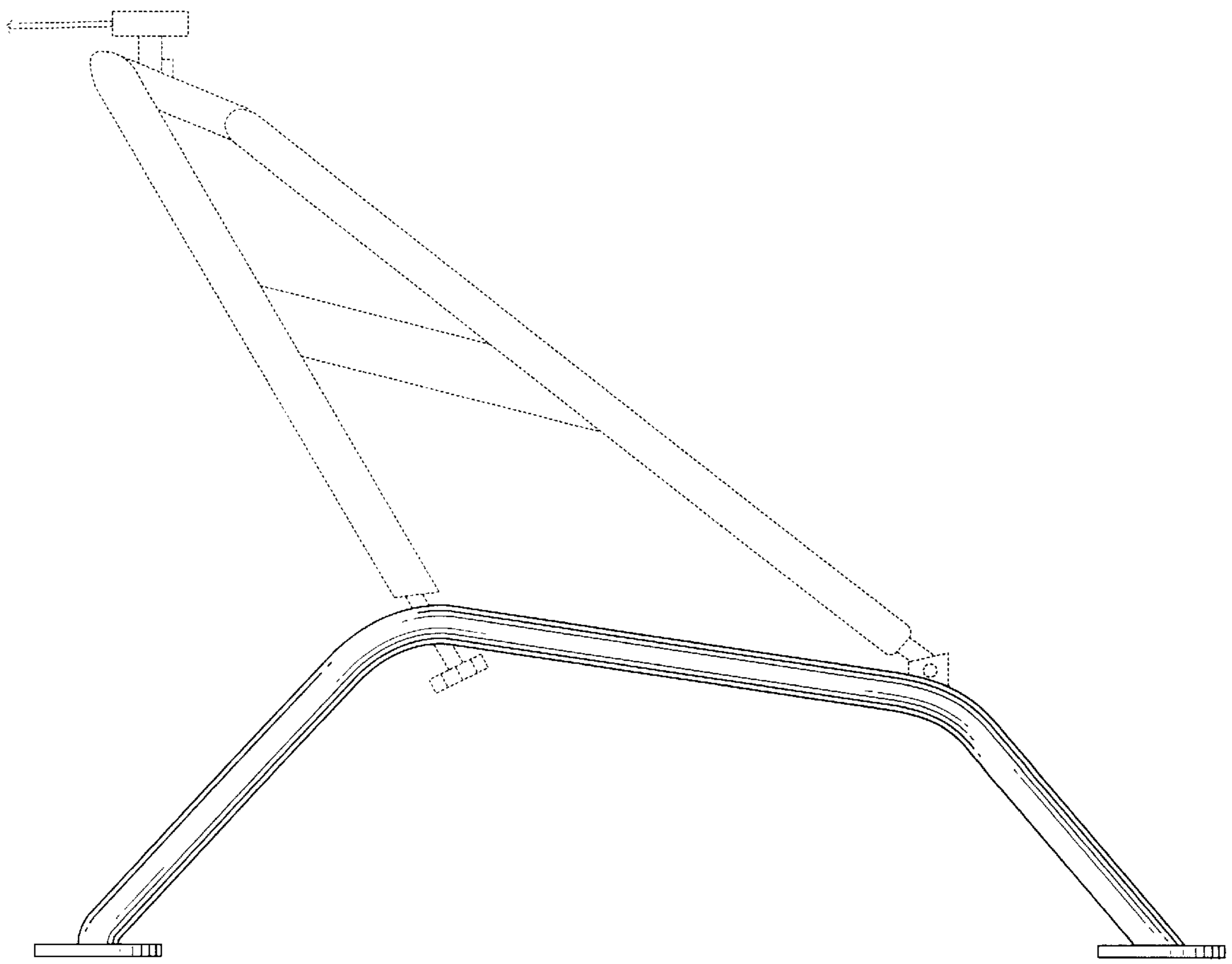
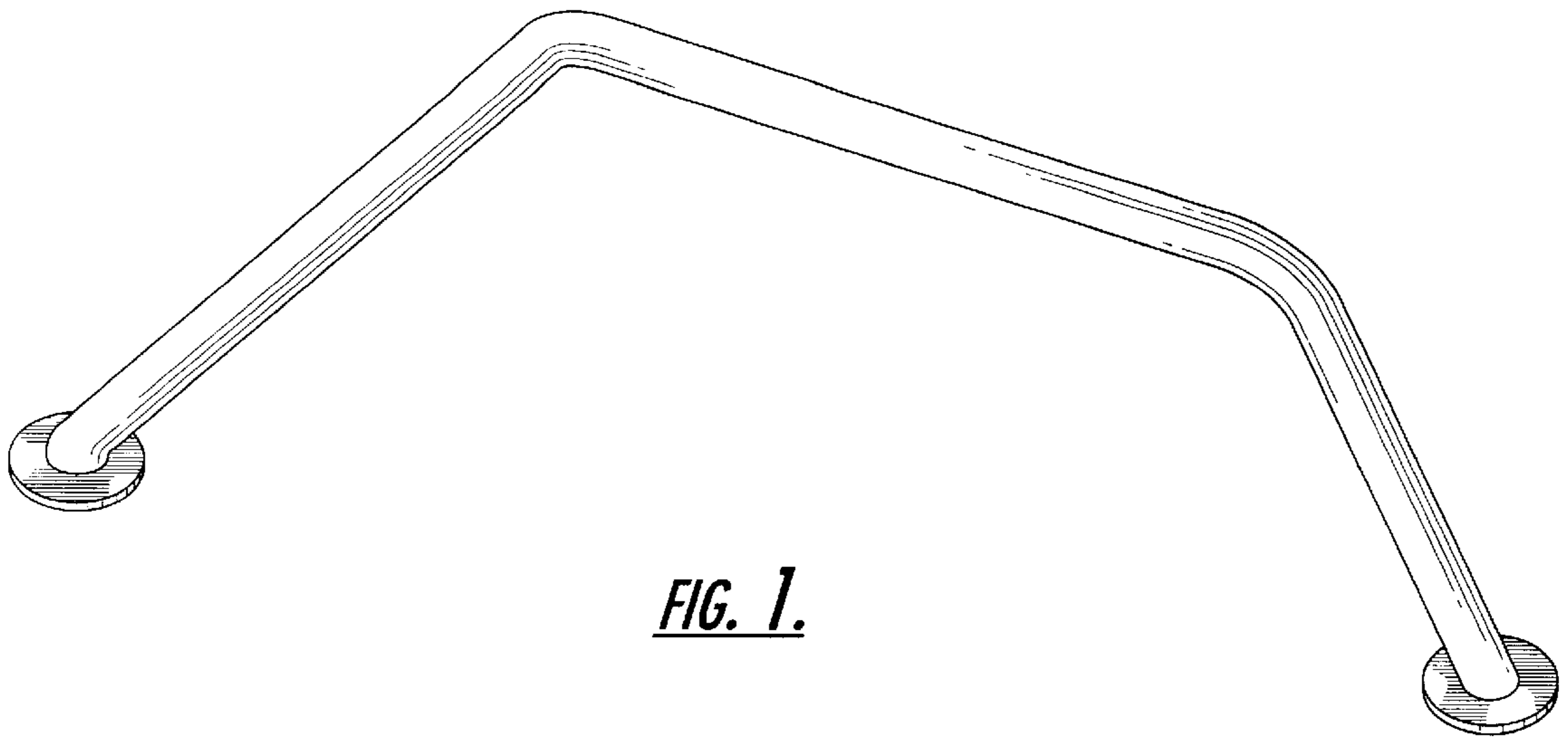

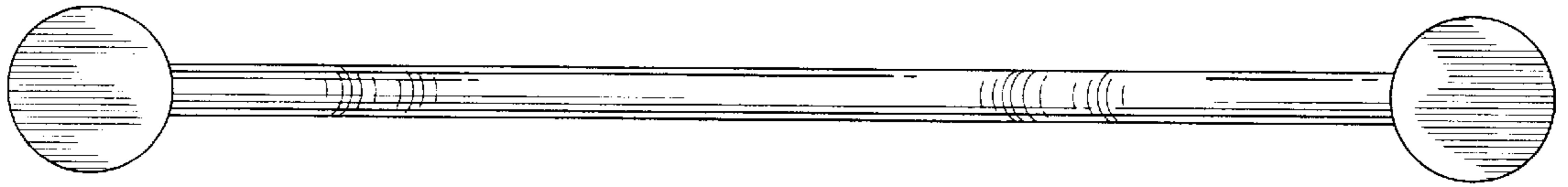

FIG. 3.

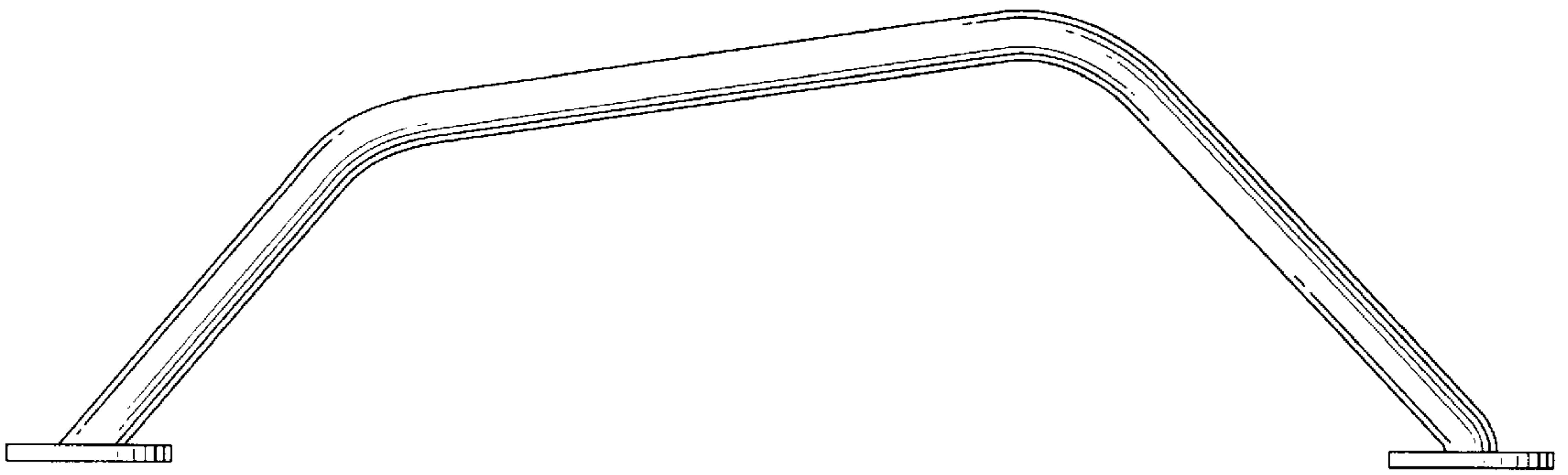

FIG. 4.

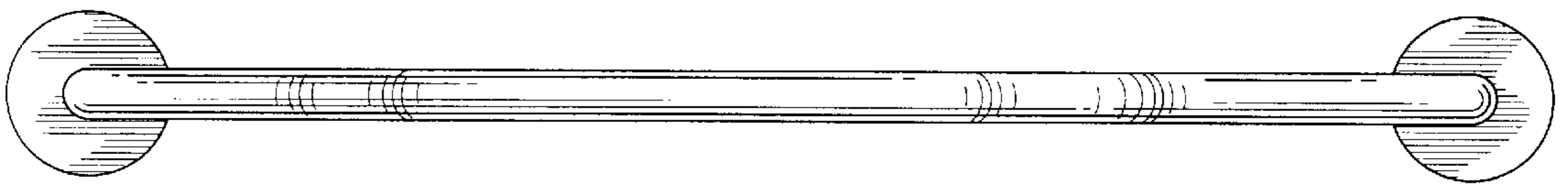

FIG. 5.

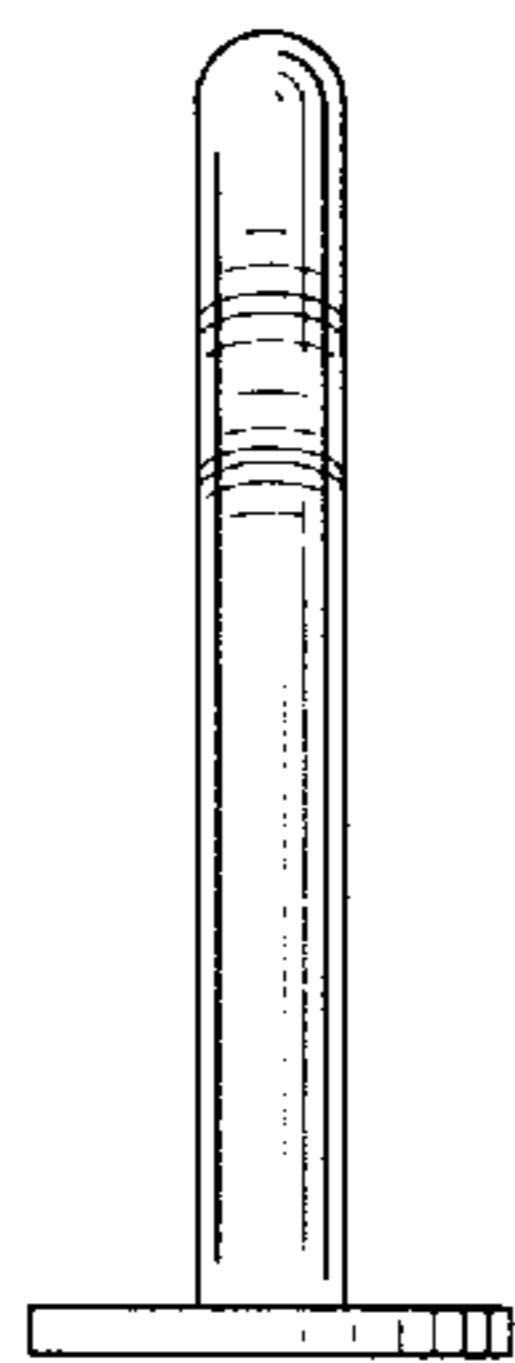

FIG. 6.

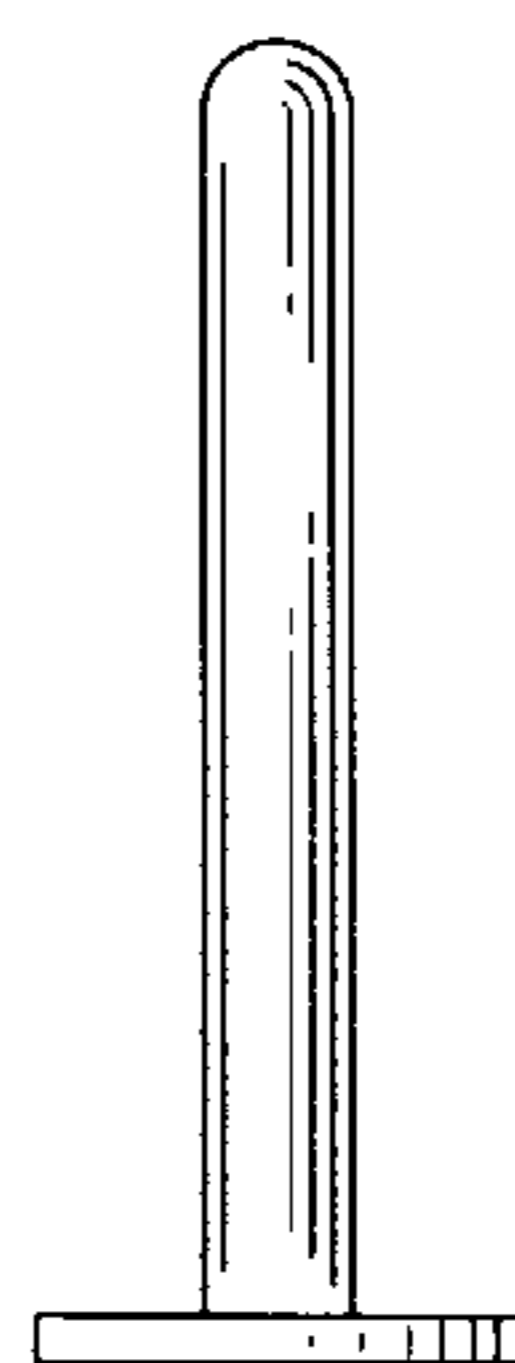

FIG. 7.

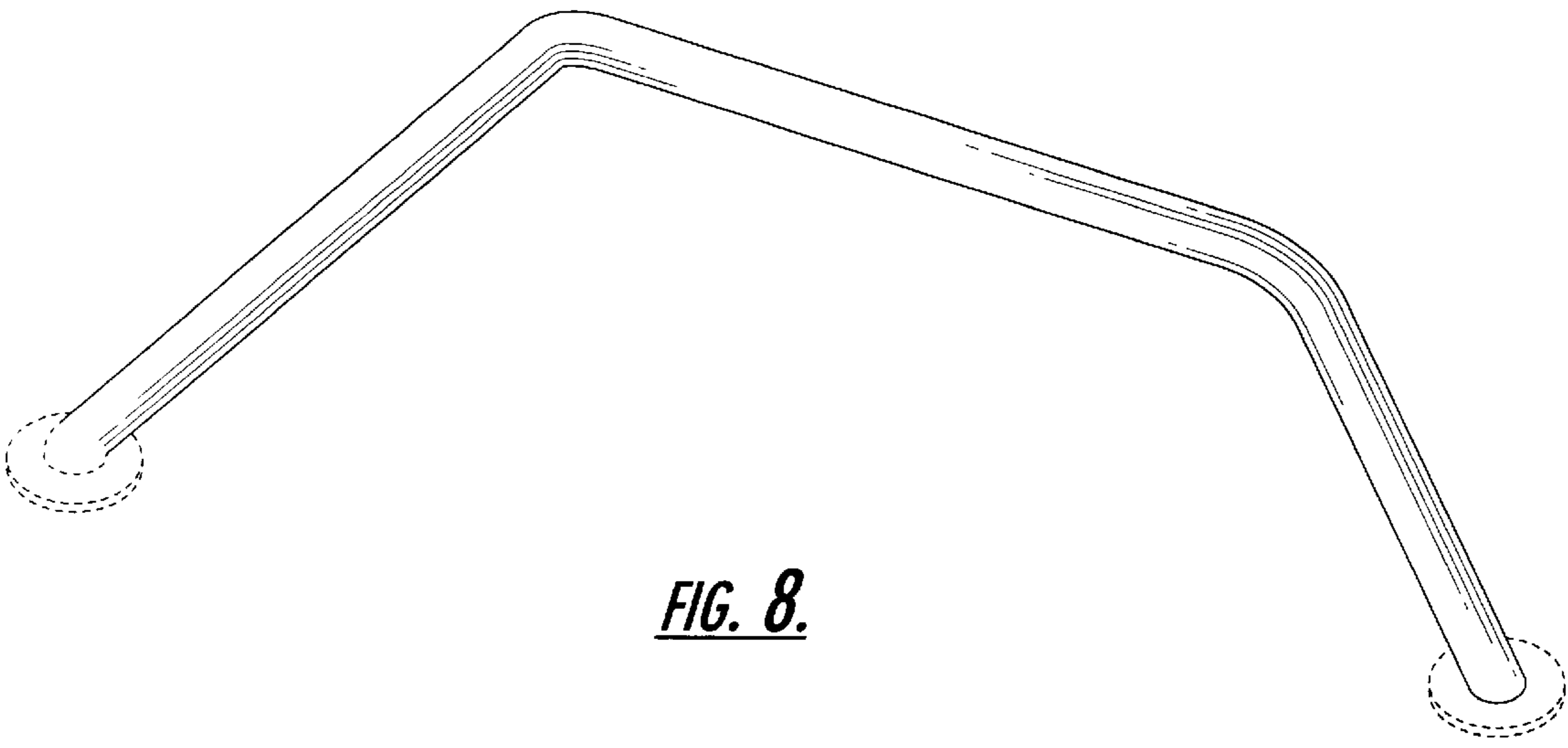

FIG. 8.

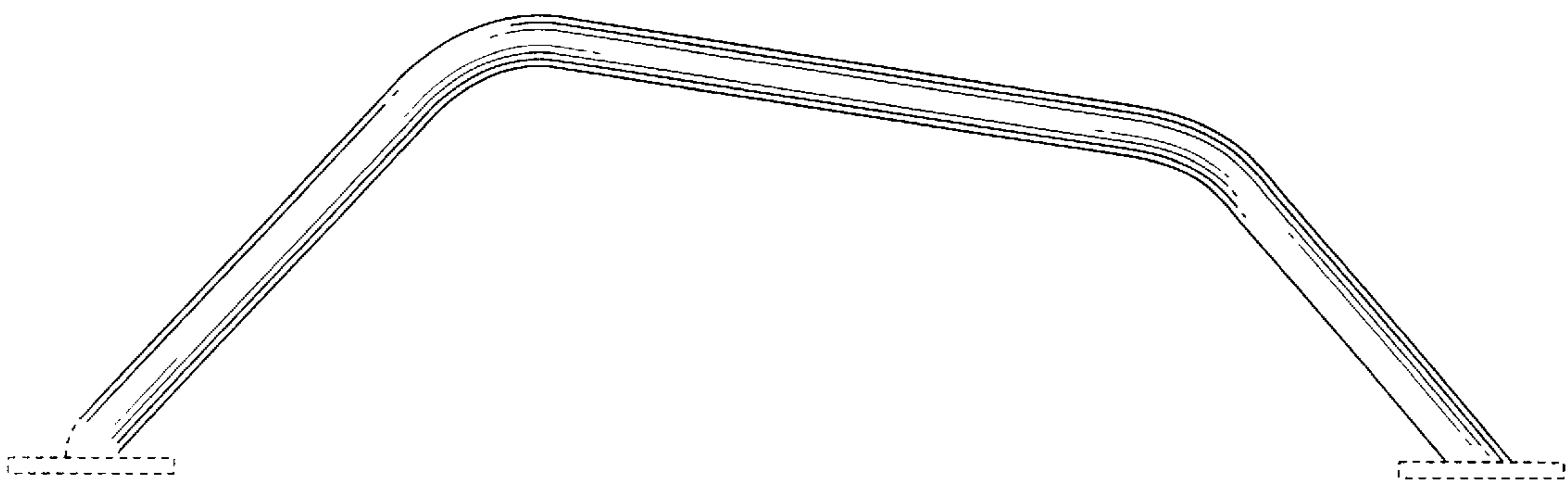

FIG. 9.

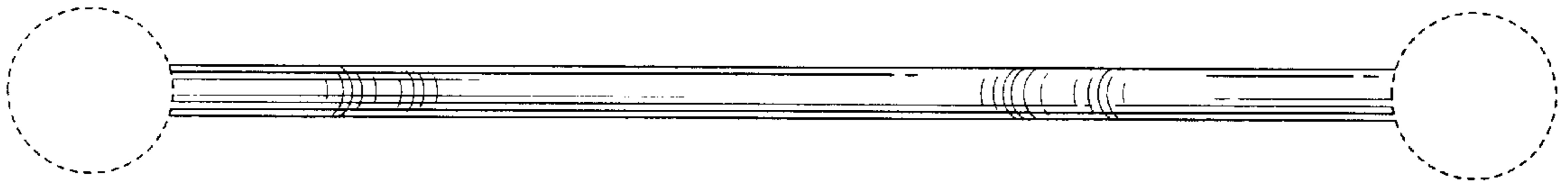

FIG. 10.

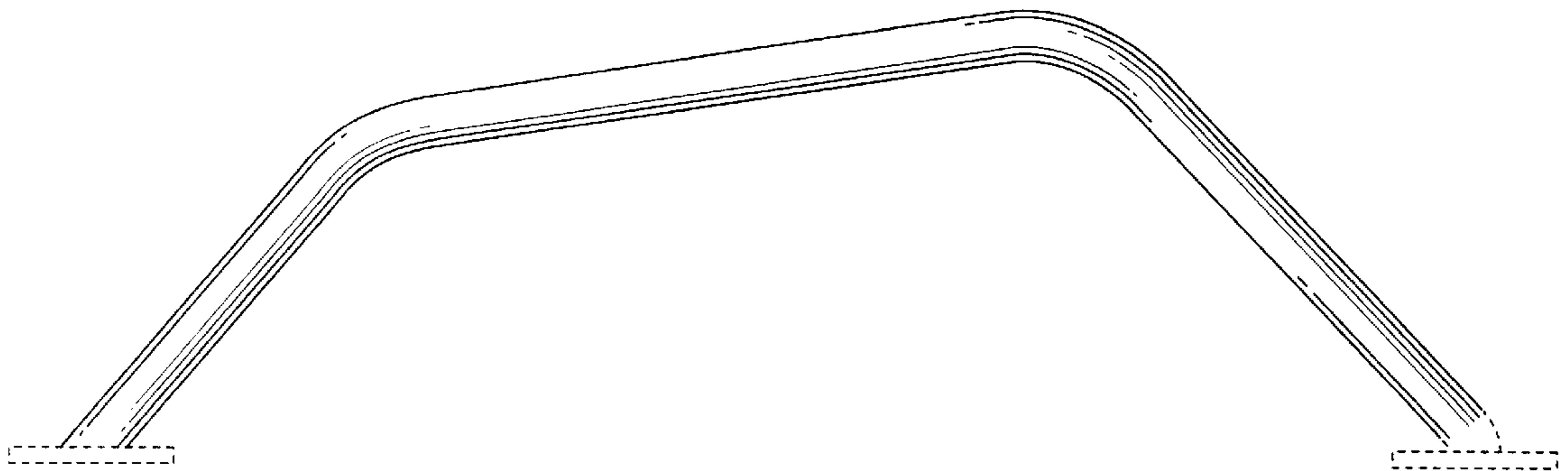

FIG. 11.

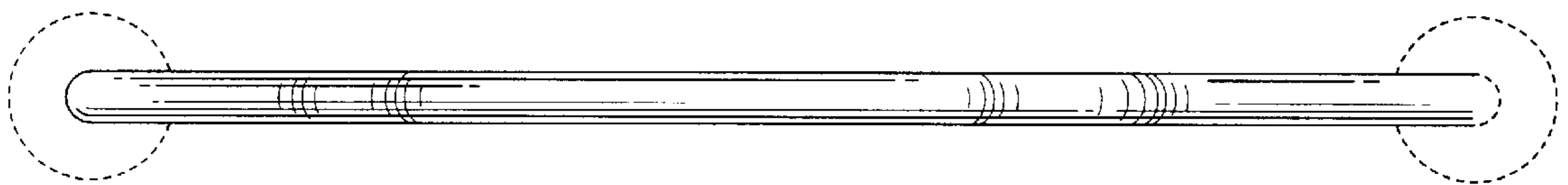

FIG. 12.

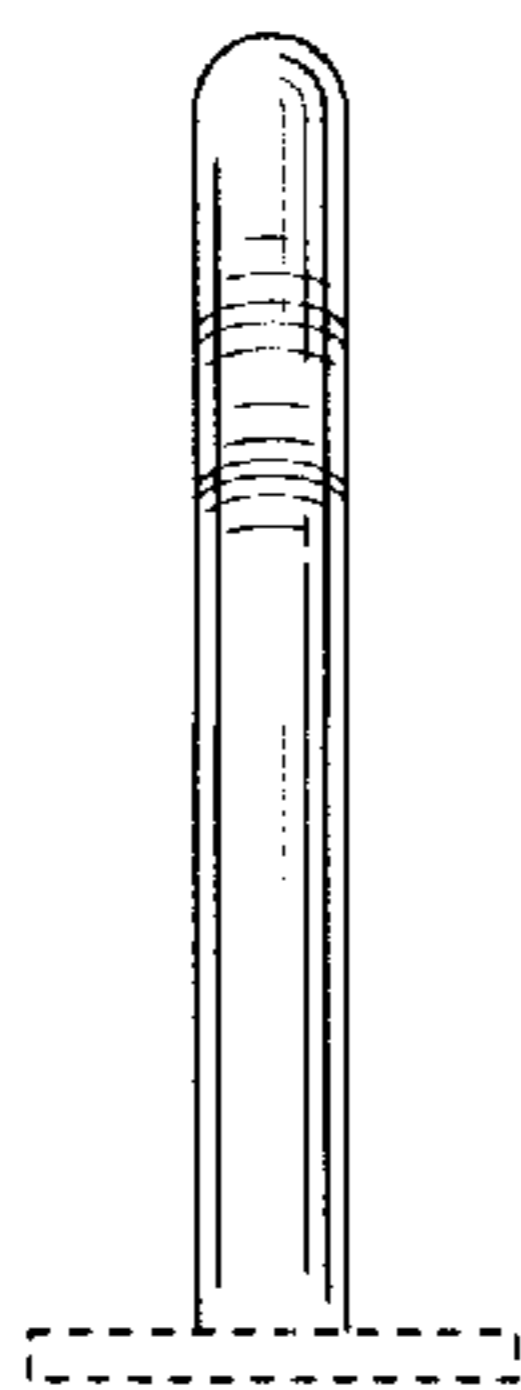

FIG. 13.

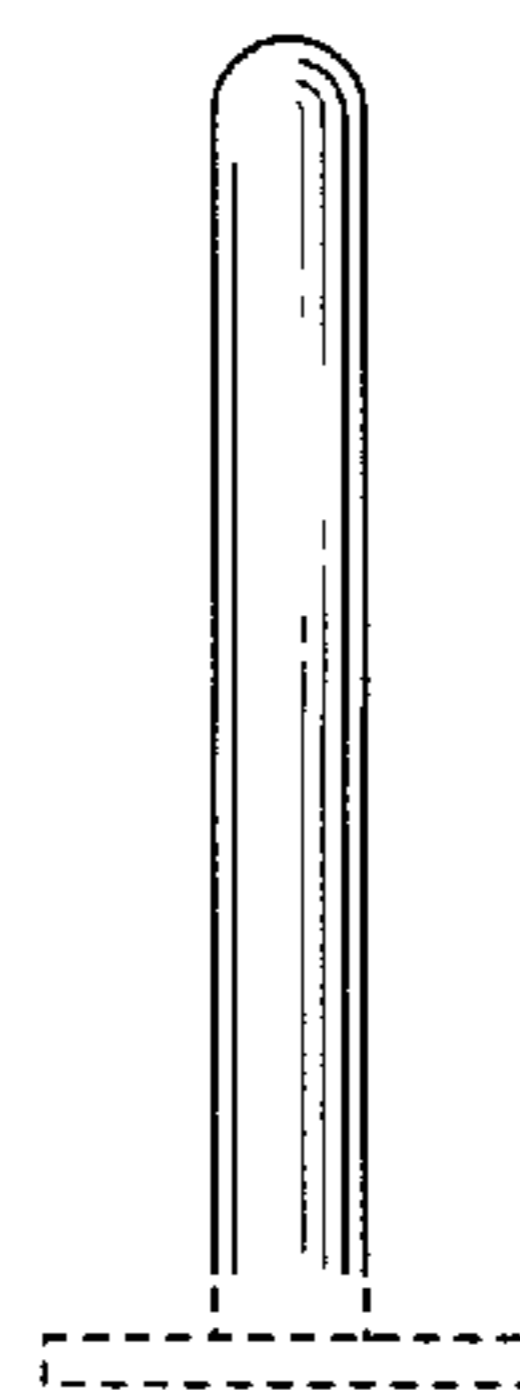

FIG. 14.

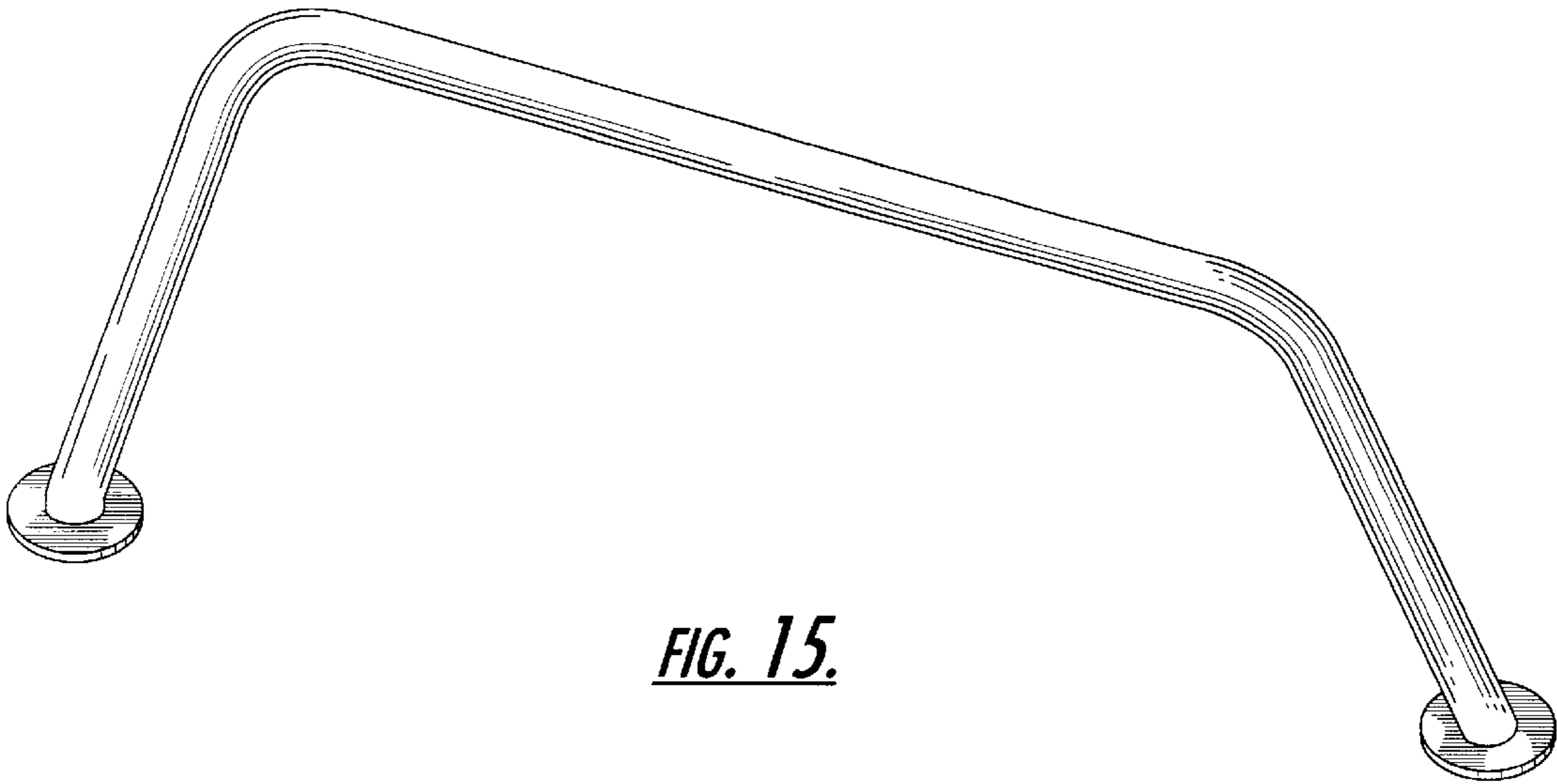

FIG. 15.

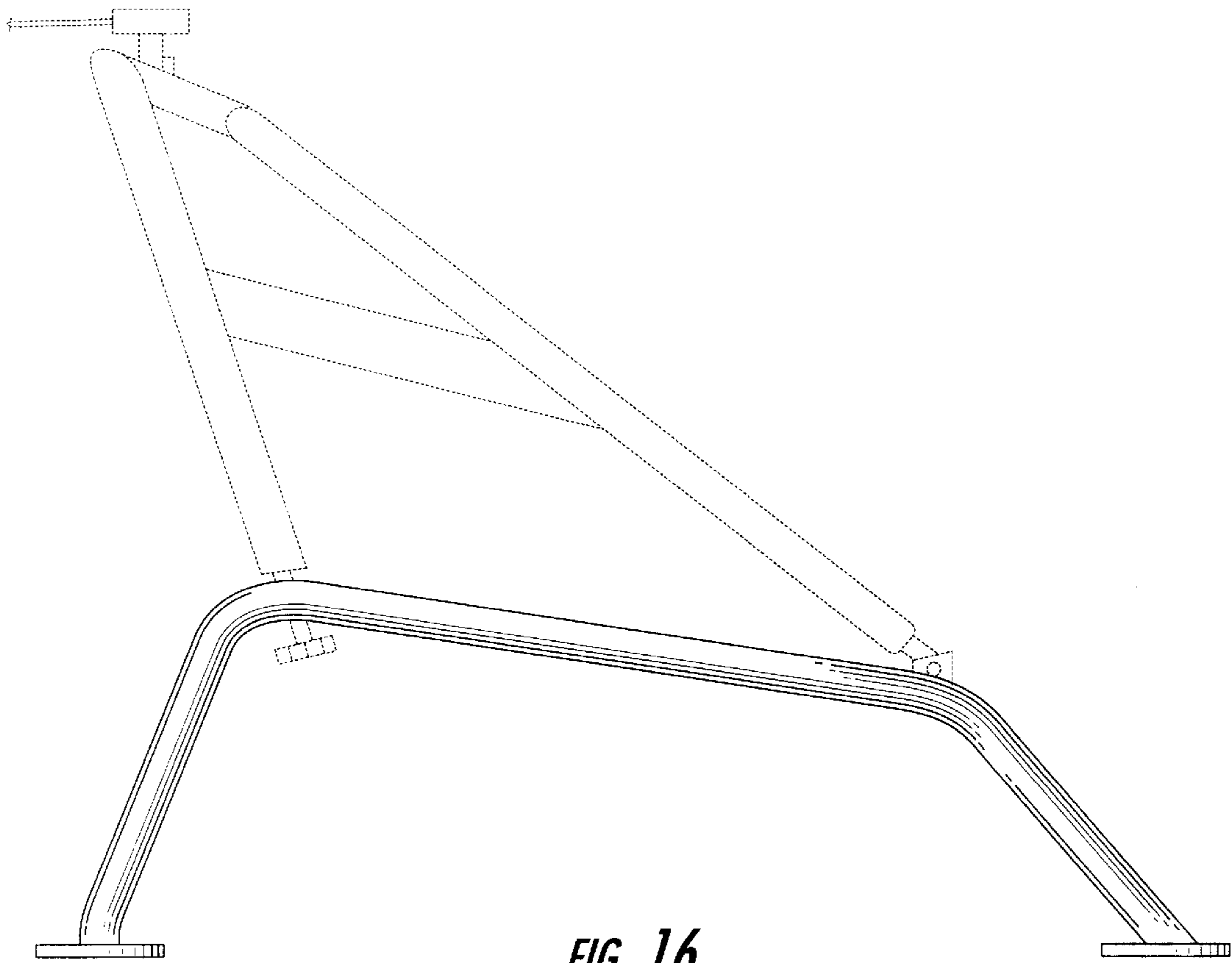

FIG. 16.



FIG. 17.

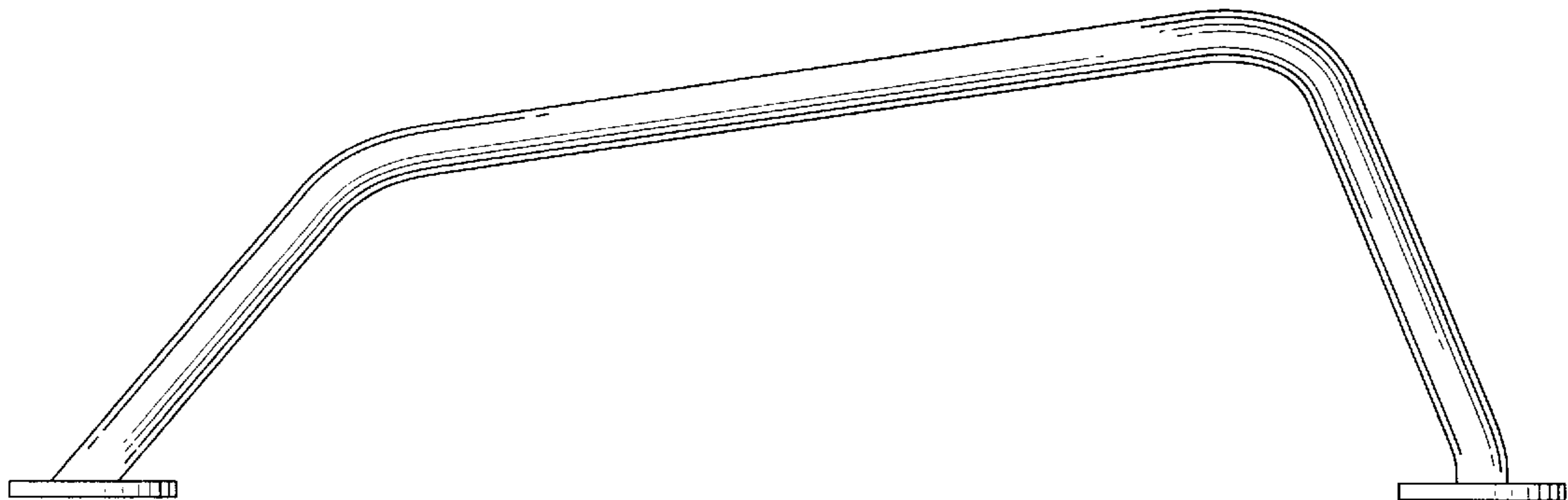

FIG. 18.

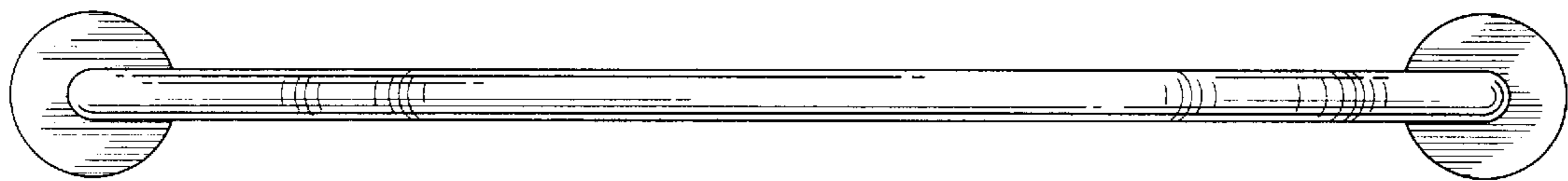

FIG. 19.

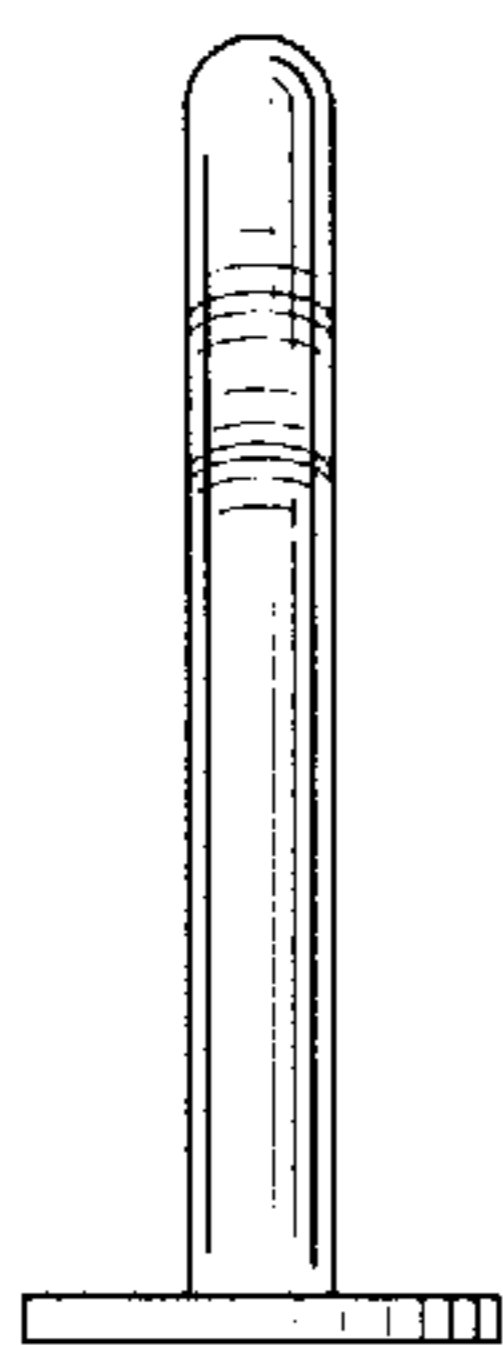

FIG. 20.

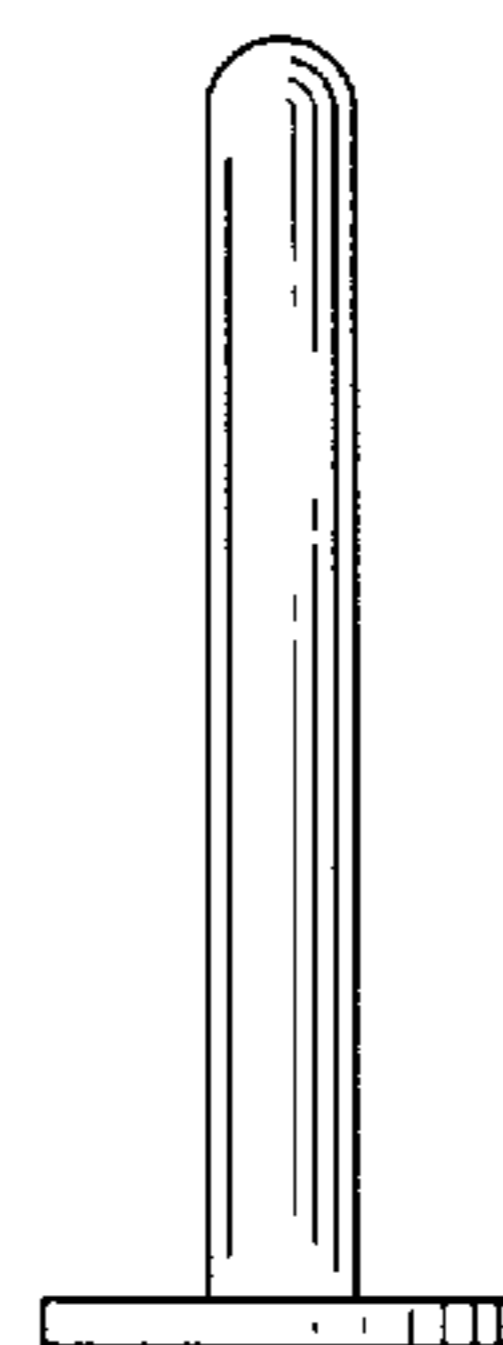

FIG. 21.

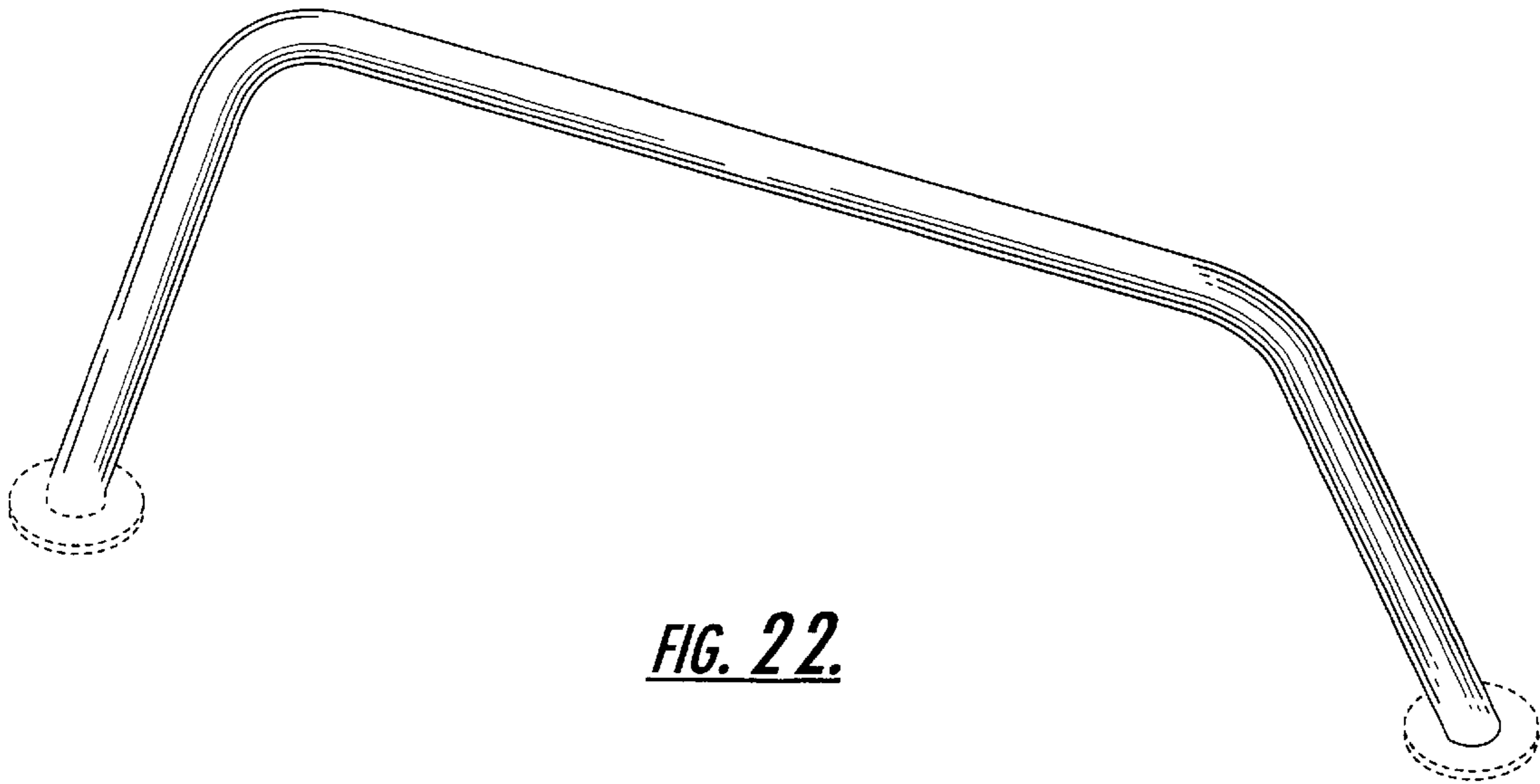

FIG. 22.

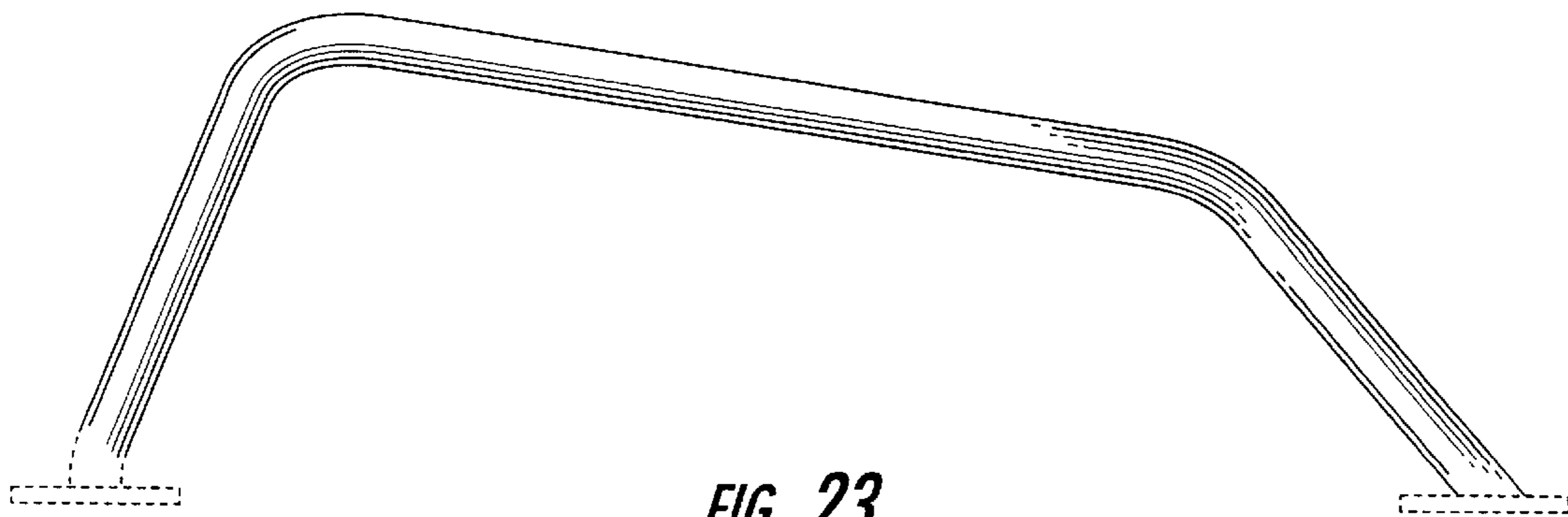

FIG. 23.

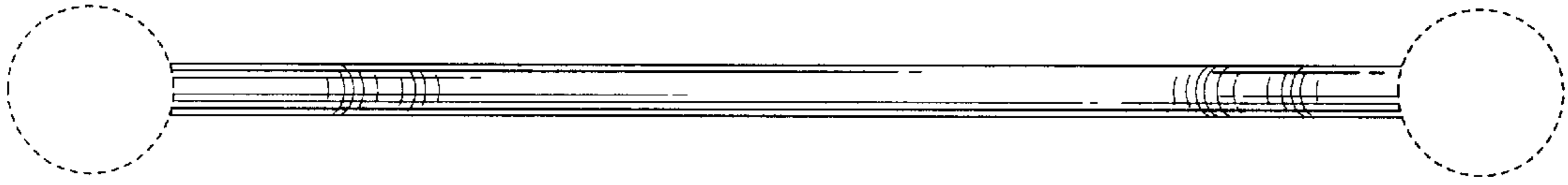

FIG. 24.

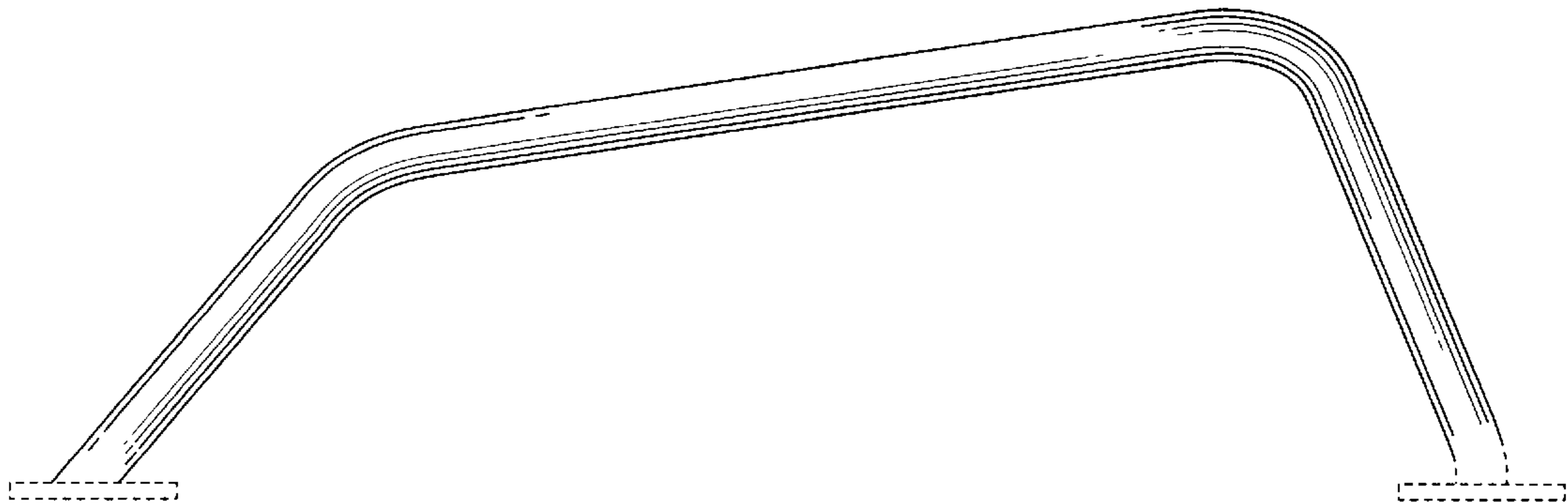

FIG. 25.

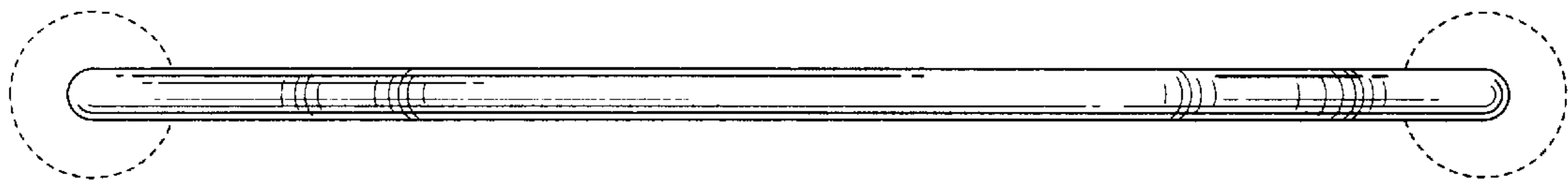

FIG. 26.

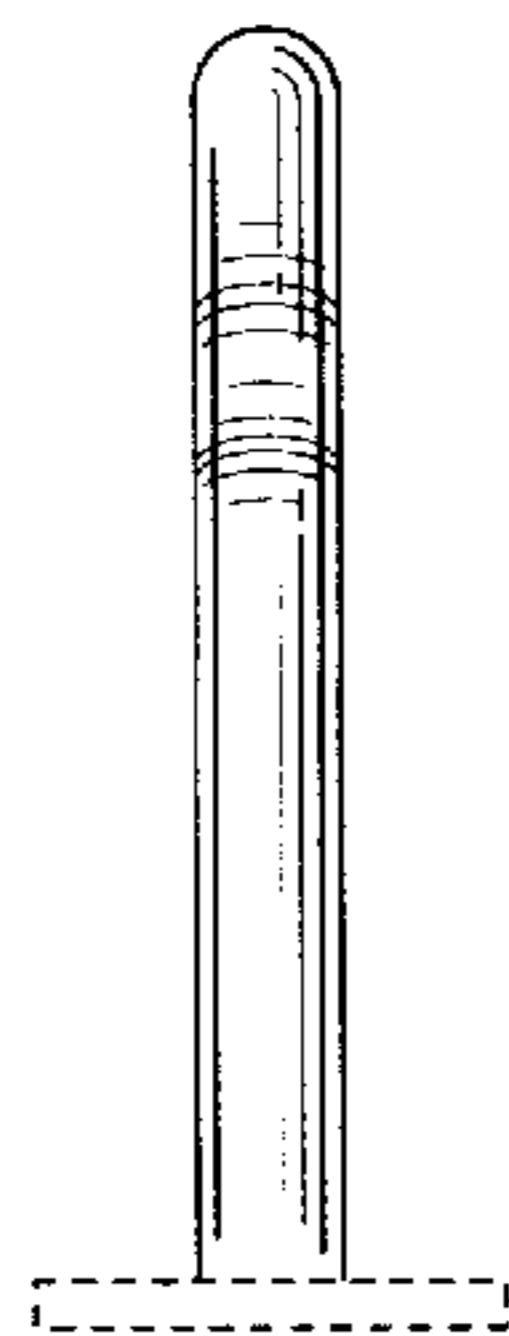

FIG. 27.

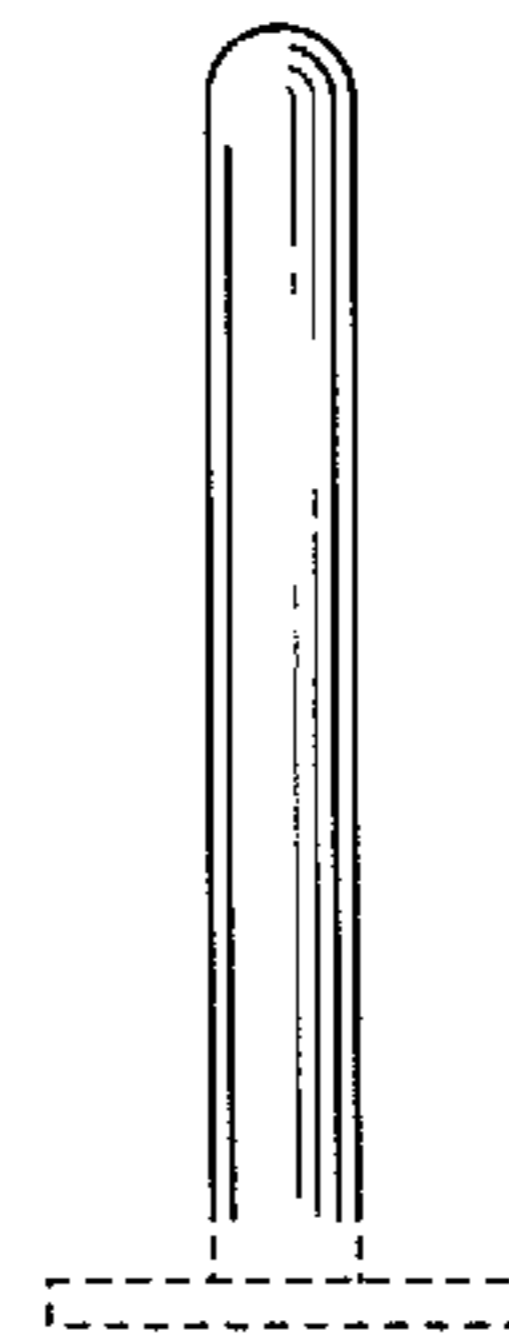

FIG. 28.