



US00D462724S

(12) **United States Design Patent**
Sugino

(10) **Patent No.:** **US D462,724 S**

(45) **Date of Patent:** **** Sep. 10, 2002**

(54) **WIRELESS COMMUNICATION ADAPTER FOR GAME MACHINE**

(75) Inventor: **Kenichi Sugino**, Kyoto (JP)

(73) Assignee: **Nintendo Co., Ltd.** (JP)

(**) Term: **14 Years**

(21) Appl. No.: **29/155,487**

(22) Filed: **Feb. 13, 2002**

Related U.S. Application Data

(62) Division of application No. 29/136,508, filed on Feb. 2, 2001.

(30) **Foreign Application Priority Data**

Aug. 7, 2000	(JP)	2000-21836
Aug. 7, 2000	(JP)	2000-21837
Aug. 7, 2000	(JP)	2000-21838
Aug. 7, 2000	(JP)	2000-21839
Aug. 7, 2000	(JP)	2000-21840
Aug. 7, 2000	(JP)	2000-21841

(51) **LOC (7) Cl.** **21-01**

(52) **U.S. Cl.** **D21/333**

(58) **Field of Search** D21/324, 333, D21/385; D14/496, 125, 217, 137; 273/148 B; 463/1, 46, 47, 30, 35; 345/328, 333, 112, 978; 369/1, 2, 3, 83, 292

(56) **References Cited**

U.S. PATENT DOCUMENTS

3,946,156 A	*	3/1976	Budrose	369/1
3,978,524 A		8/1976	Gordon et al.		
4,422,105 A	*	12/1983	Rodesch et al.	345/978
4,578,674 A		3/1986	Baker et al.		
D303,127 S		8/1989	Biasotti		
D305,230 S	*	12/1989	Math	D14/239
D324,244 S		2/1992	Stamper et al.		
D325,049 S		3/1992	Cordell		

D372,274 S	7/1996	Douglas et al.
5,586,090 A	12/1996	Otte
D419,136 S	1/2000	Tomizawa
6,182,030 B1	1/2001	Hagan et al.
D438,179 S	2/2001	Wang-Tsai
D440,980 S	4/2001	Chung

* cited by examiner

Primary Examiner—Prabhakar Deshmukh

(74) *Attorney, Agent, or Firm*—Nixon & Vanderhye P.C.

(57) **CLAIM**

The ornamental design for a wireless communication adapter for game machine, as shown and described.

DESCRIPTION

FIG. 1 is a front elevational view of a wireless communication adapter for game machine showing a first embodiment;

FIG. 2 is a top plan view thereof;

FIG. 3 is a rear elevational view thereof;

FIG. 4 is a bottom plan view thereof;

FIG. 5 is a right side view thereof, the left side view being a mirror image thereof;

FIG. 6 is a front elevational view of a wireless communication adapter for game machine showing a second embodiment;

FIG. 7 is a top plan view thereof;

FIG. 8 is a rear elevational view thereof;

FIG. 9 is a bottom plan view thereof;

FIG. 10 is a right side view thereof, the left side view being a mirror image thereof;

FIG. 11 is a front elevational view of a wireless communication adapter for game machine showing a third embodiment;

FIG. 12 is a top plan view thereof;

FIG. 13 is a rear elevational view thereof;

FIG. 14 is a bottom plan view thereof; and,

FIG. 15 is a right side view thereof, the left side view being a mirror image thereof.

1 Claim, 15 Drawing Sheets

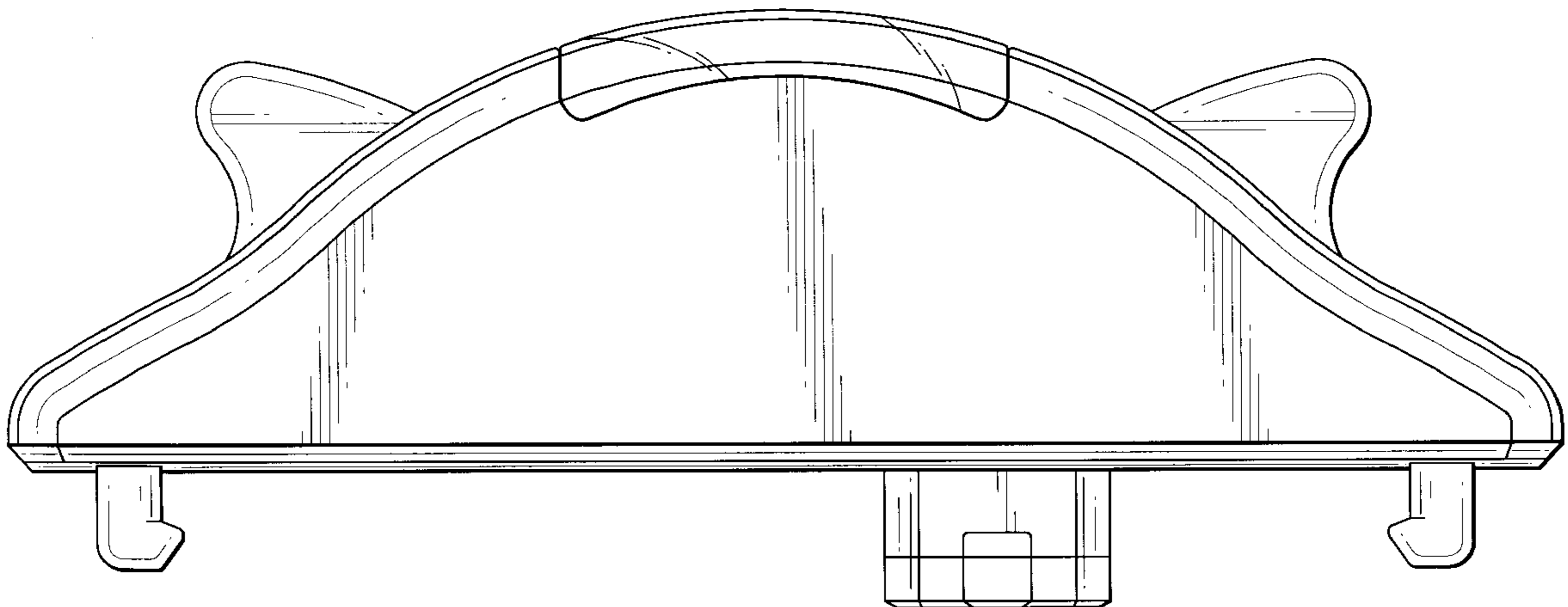

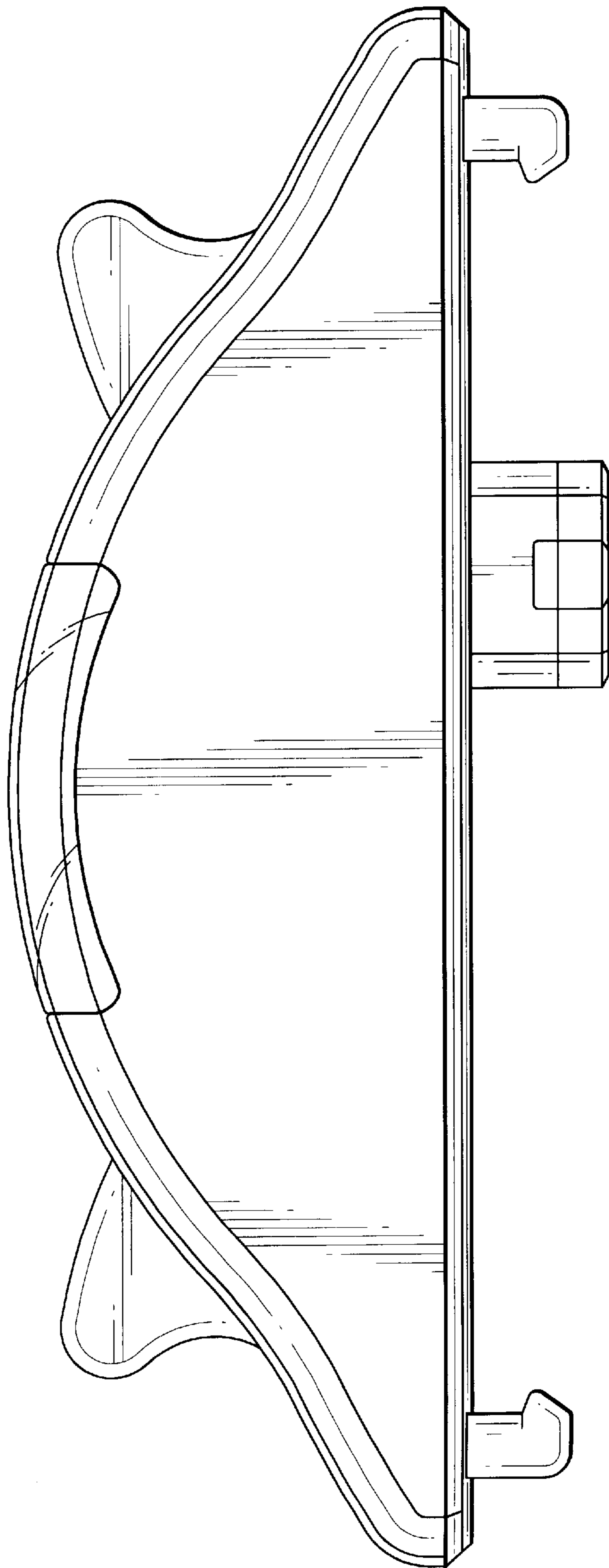

Fig. 1

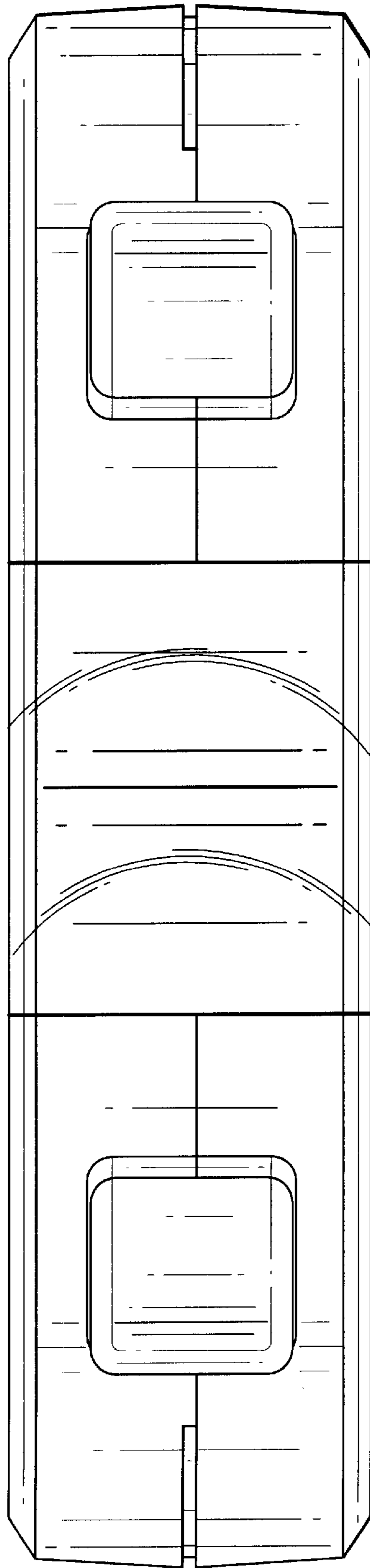

Fig. 2

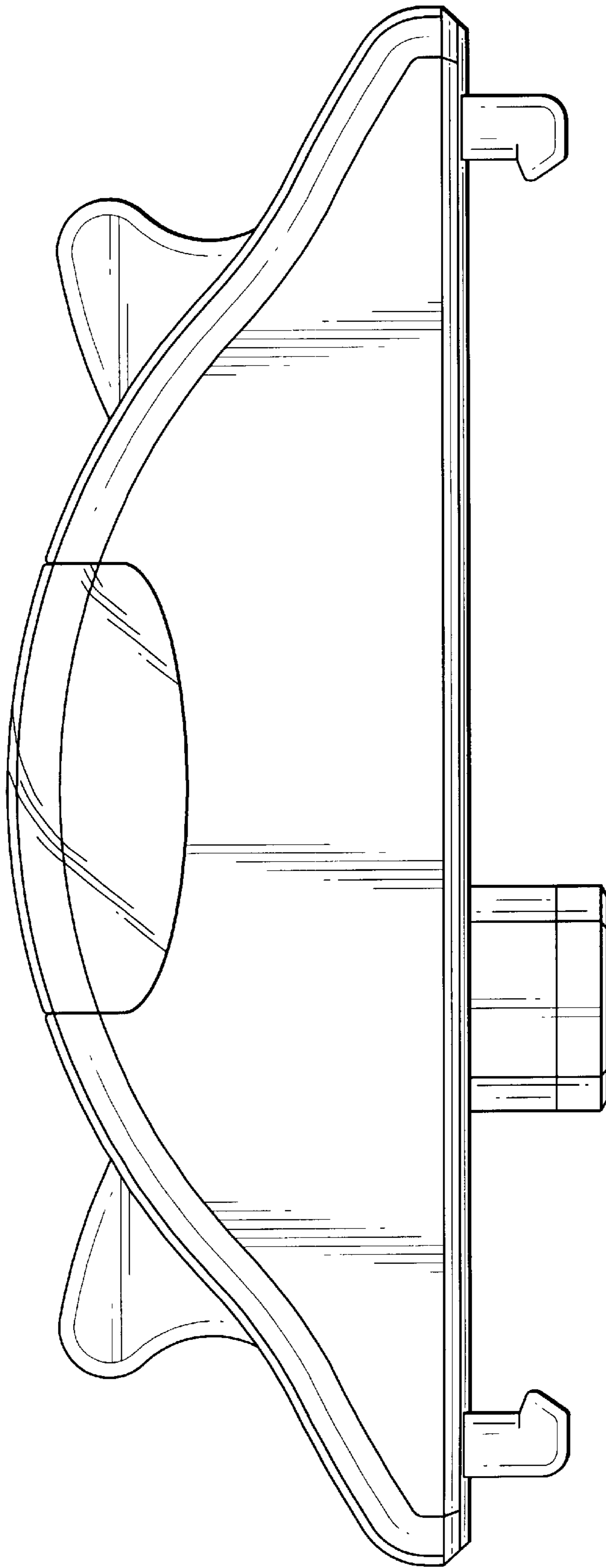

Fig. 3

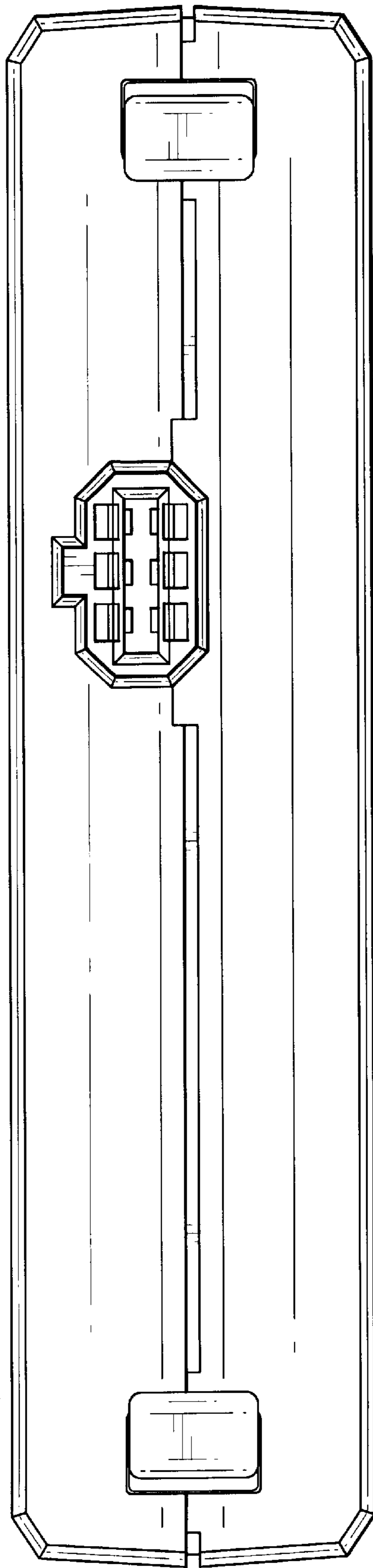

Fig. 4

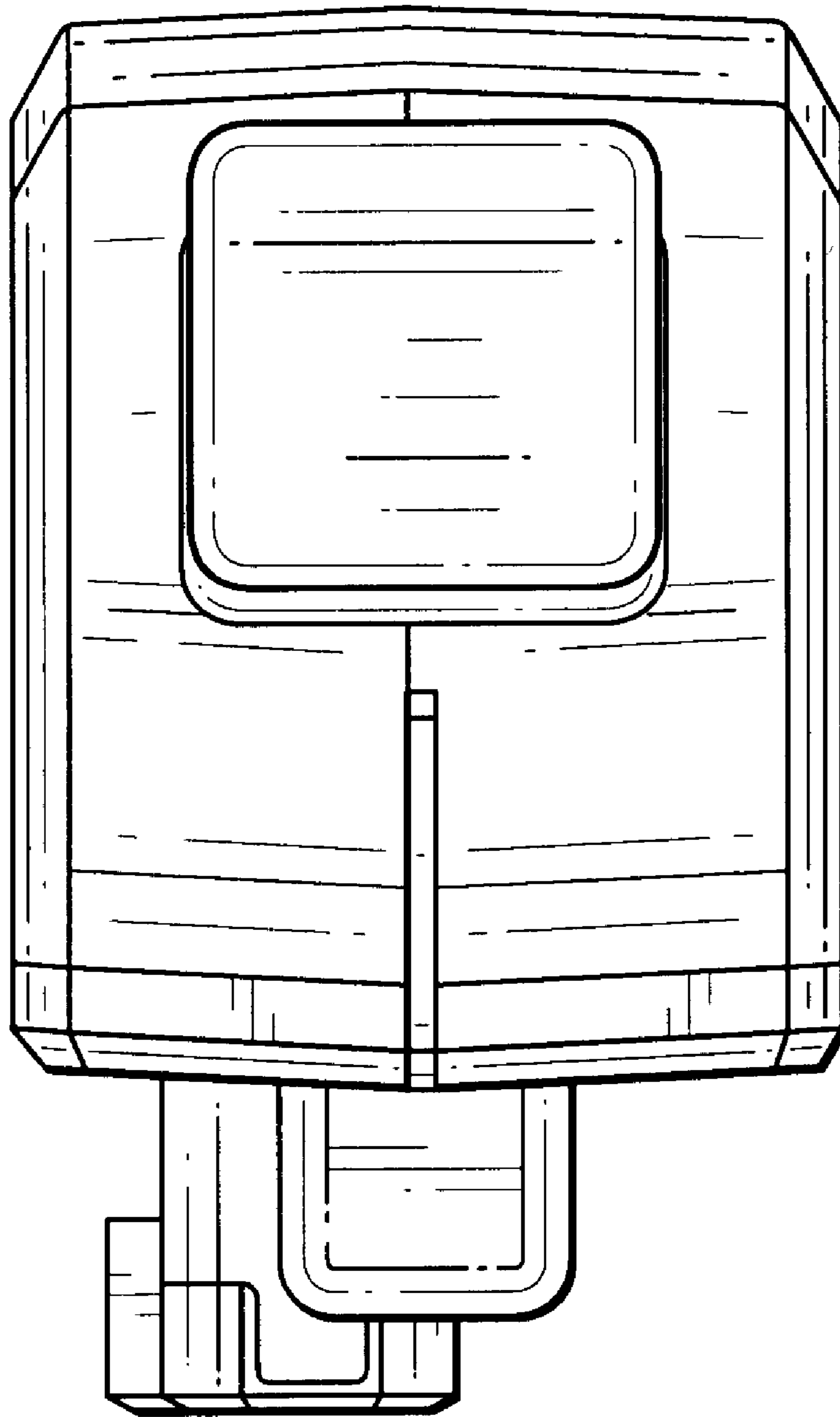

Fig. 5

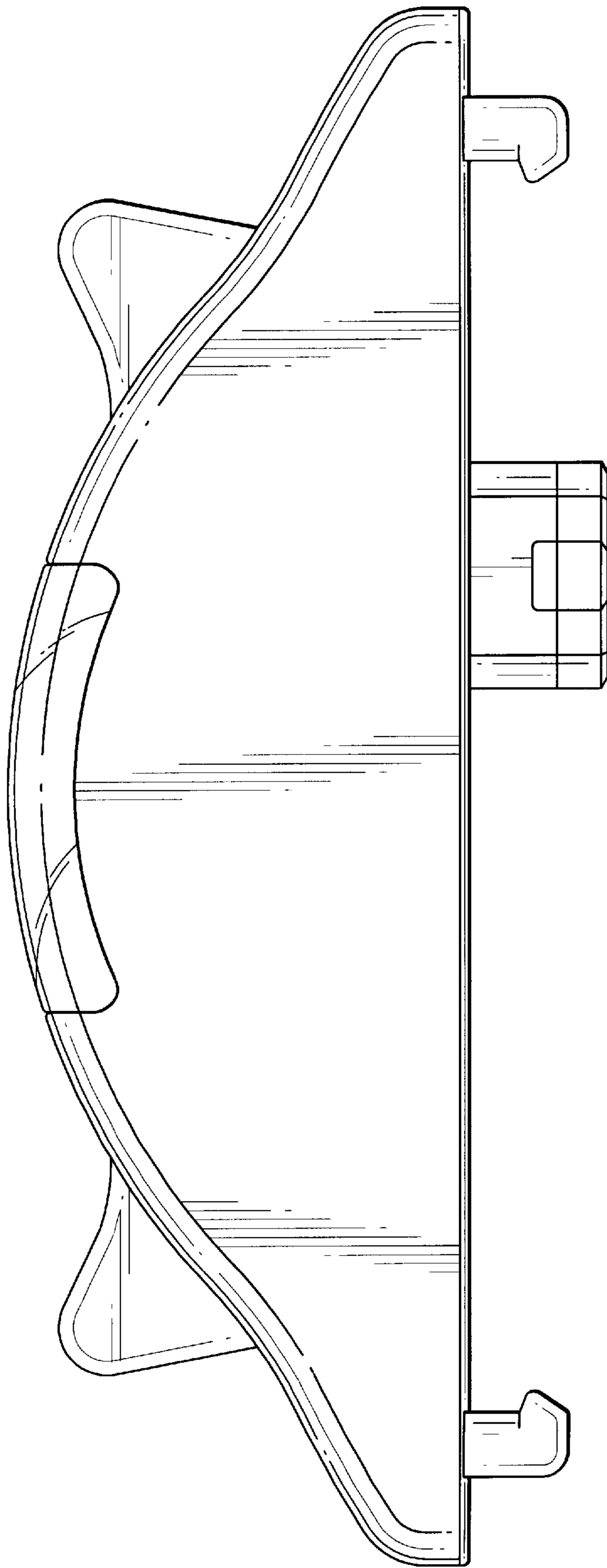

Fig. 6

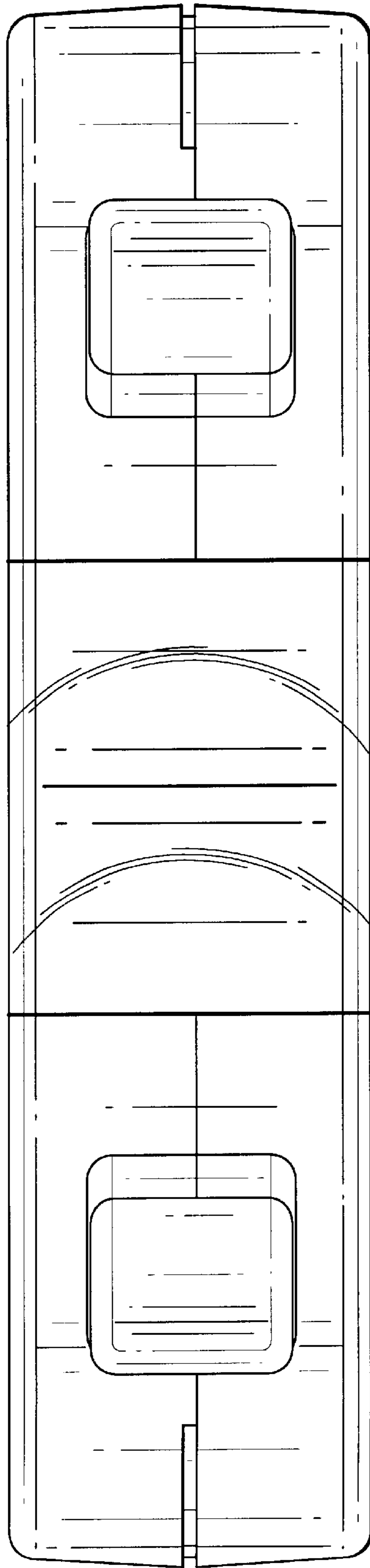

Fig. 7

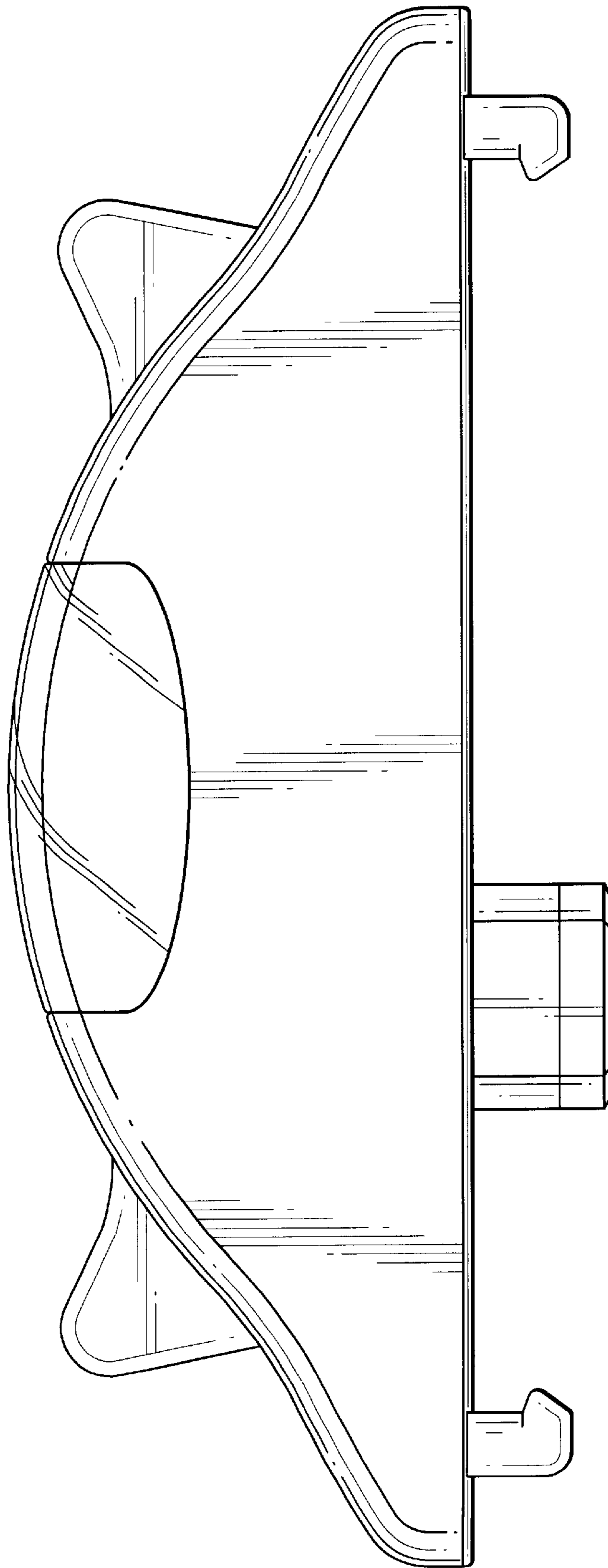

Fig. 8

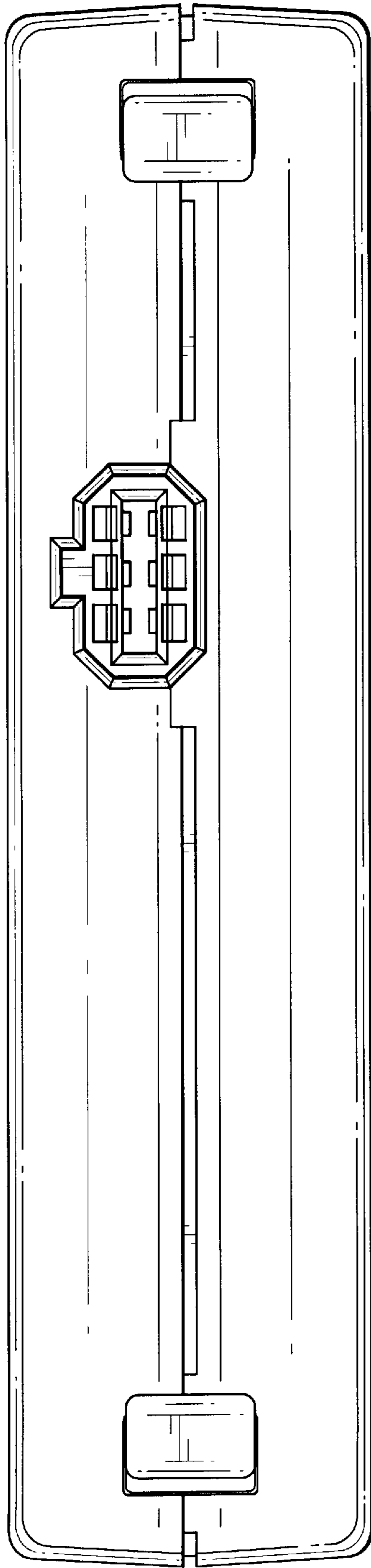

Fig. 9

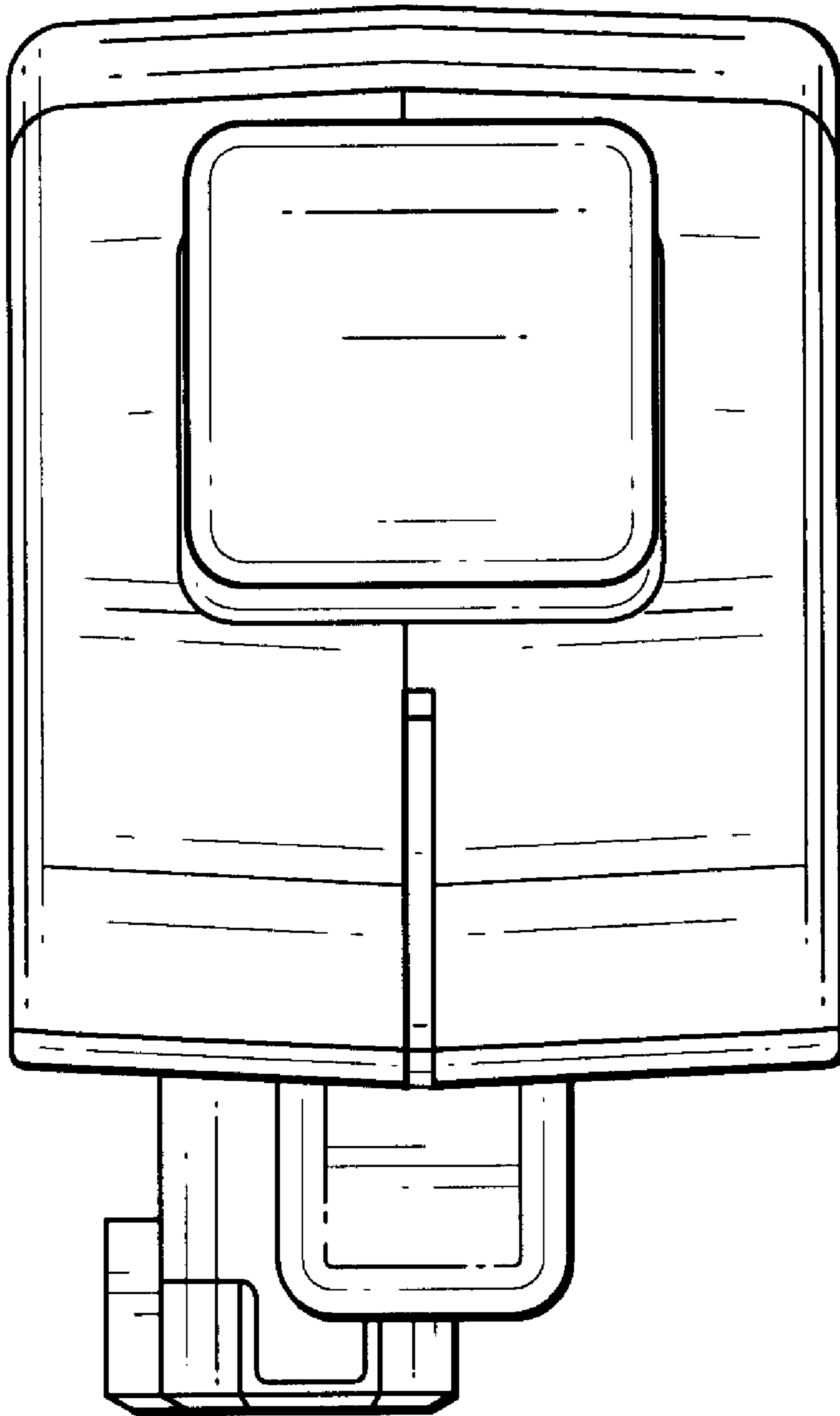

Fig. 10

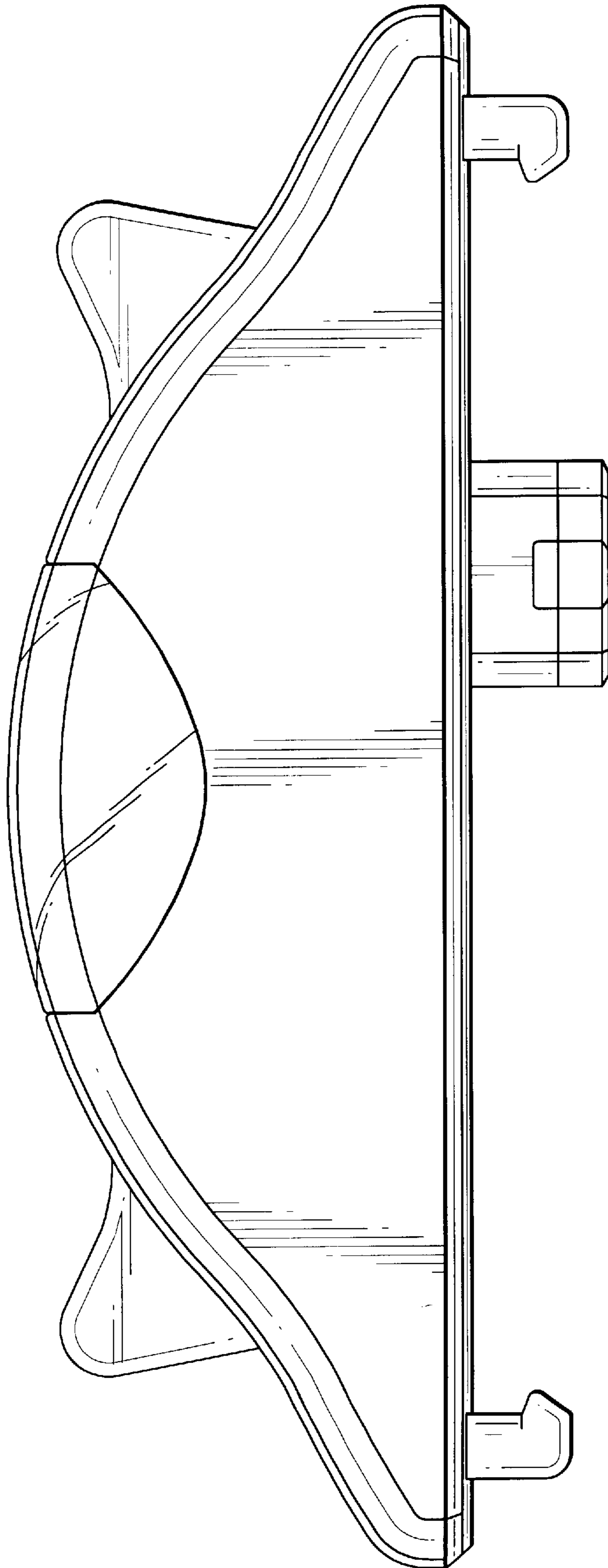

Fig. 11

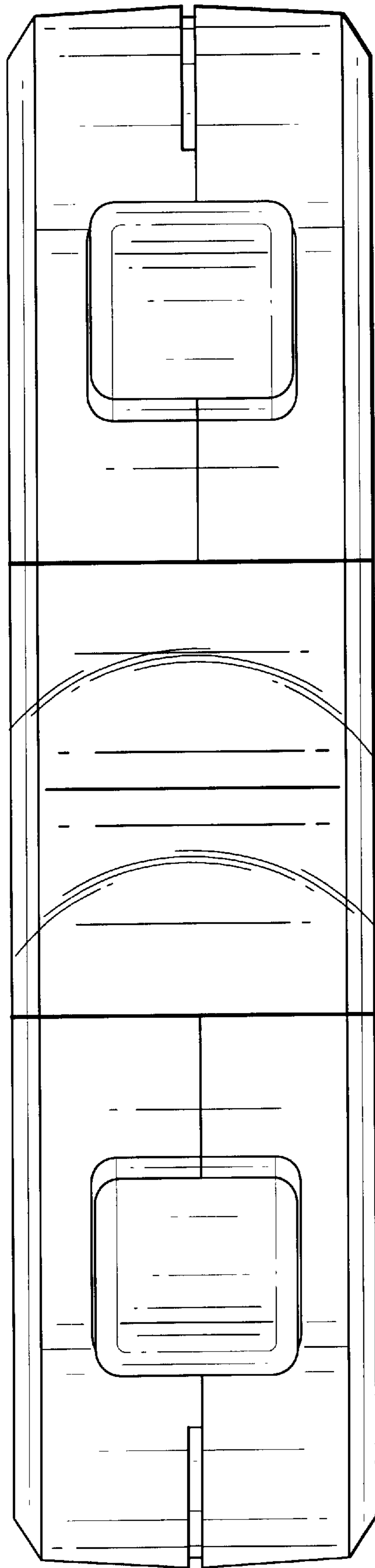

Fig. 12

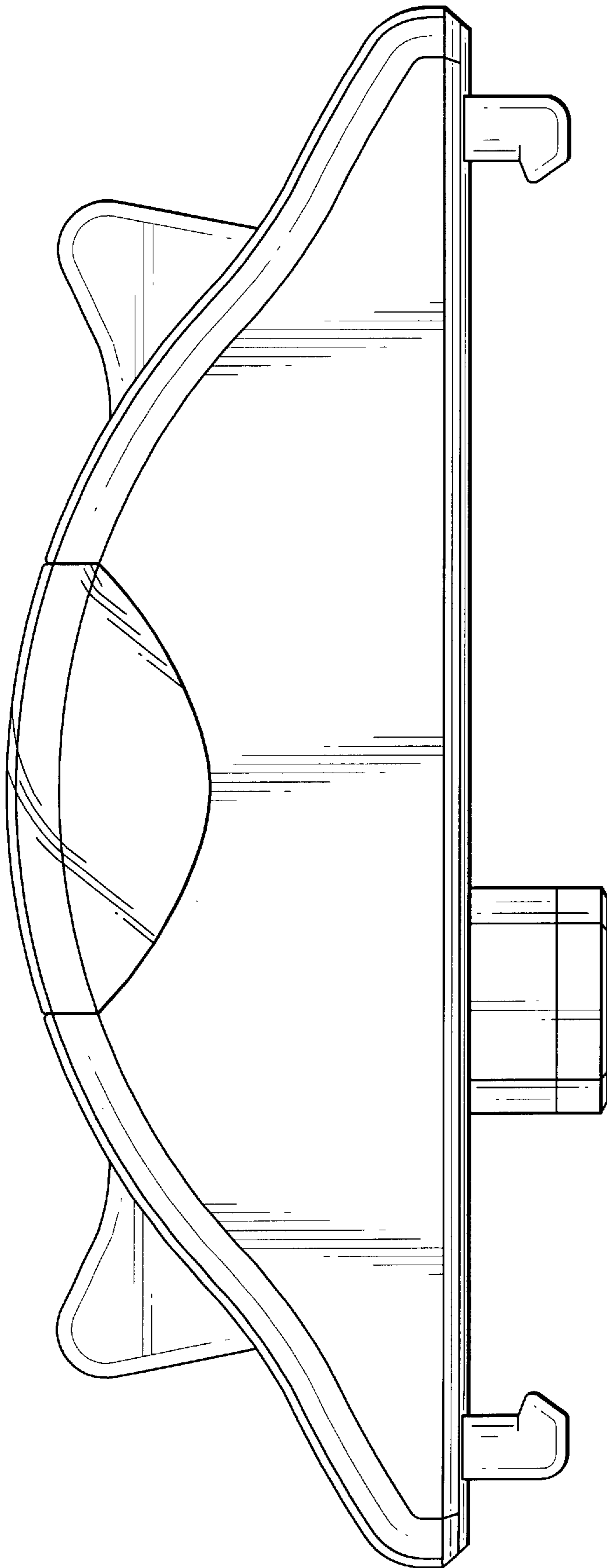

Fig. 13

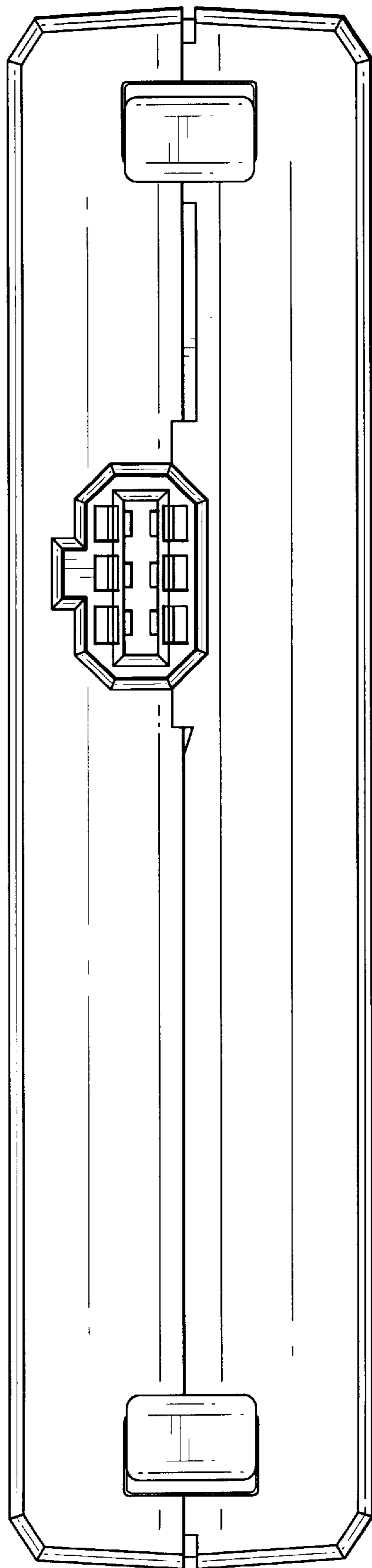

Fig. 14

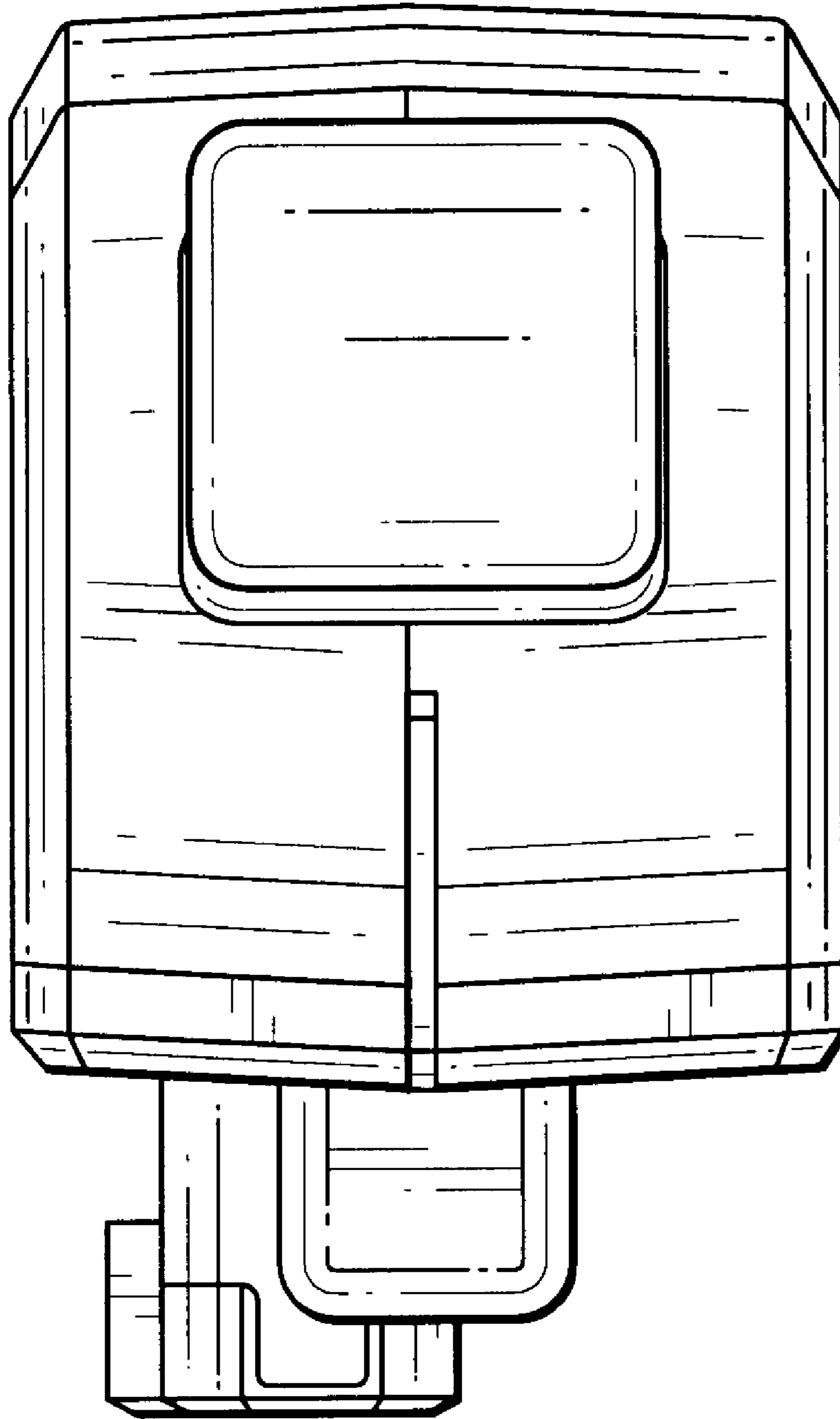

Fig. 15