



US00D462370S

(12) **United States Design Patent**
Vrilakas

(10) **Patent No.:** **US D462,370 S**

(45) **Date of Patent:** **** Sep. 3, 2002**

(54) **DRIVE LINE SPINDLE RESTRAINT**

Dentino, Gibson, Di Giusto, Hodell & West

(76) Inventor: **Andrew M. Vrilakas**, 1816 Beverly Way, Sacramento, CA (US) 95818

(57) **CLAIM**

(**) Term: **14 Years**

The ornamental design for a drive line spindle restraint, as shown and described.

(21) Appl. No.: **29/148,882**

DESCRIPTION

(22) Filed: **Sep. 27, 2001**

(51) **LOC (7) Cl.** **15-09**

(52) **U.S. Cl.** **D15/140**

(58) **Field of Search** D10/46; D15/140;
73/514.15, 514.17, 514.31-514.38, 475-477,
466, 473; 269/57, 81

FIG. 1 is a right front perspective of a drive line spindle restraint, showing my new design;
FIG. 2 is a front elevational view, thereof;
FIG. 3 is an elevational view of the left-hand side, thereof;
FIG. 4 is an elevational view of the right-hand side, thereof;
FIG. 5 is a rear elevational view, thereof;
FIG. 6 is a top plan view, thereof;
FIG. 7 is a bottom plan view, thereof; and,
FIG. 8 is a right-front perspective view, thereof, taken to a reduced scale, showing the article with its upper half in a raised, unclamped position, the drive-line spindle, support frame, and bearing shown in broken line being included solely for illustrative purposes, forming no part of the claimed design.

(56) **References Cited**

U.S. PATENT DOCUMENTS

4,685,333 A * 8/1987 Wilson et al. 73/478

* cited by examiner

Primary Examiner—Antoine Duval Davis

(74) *Attorney, Agent, or Firm*—R. Michael West; Boutin,

1 Claim, 3 Drawing Sheets

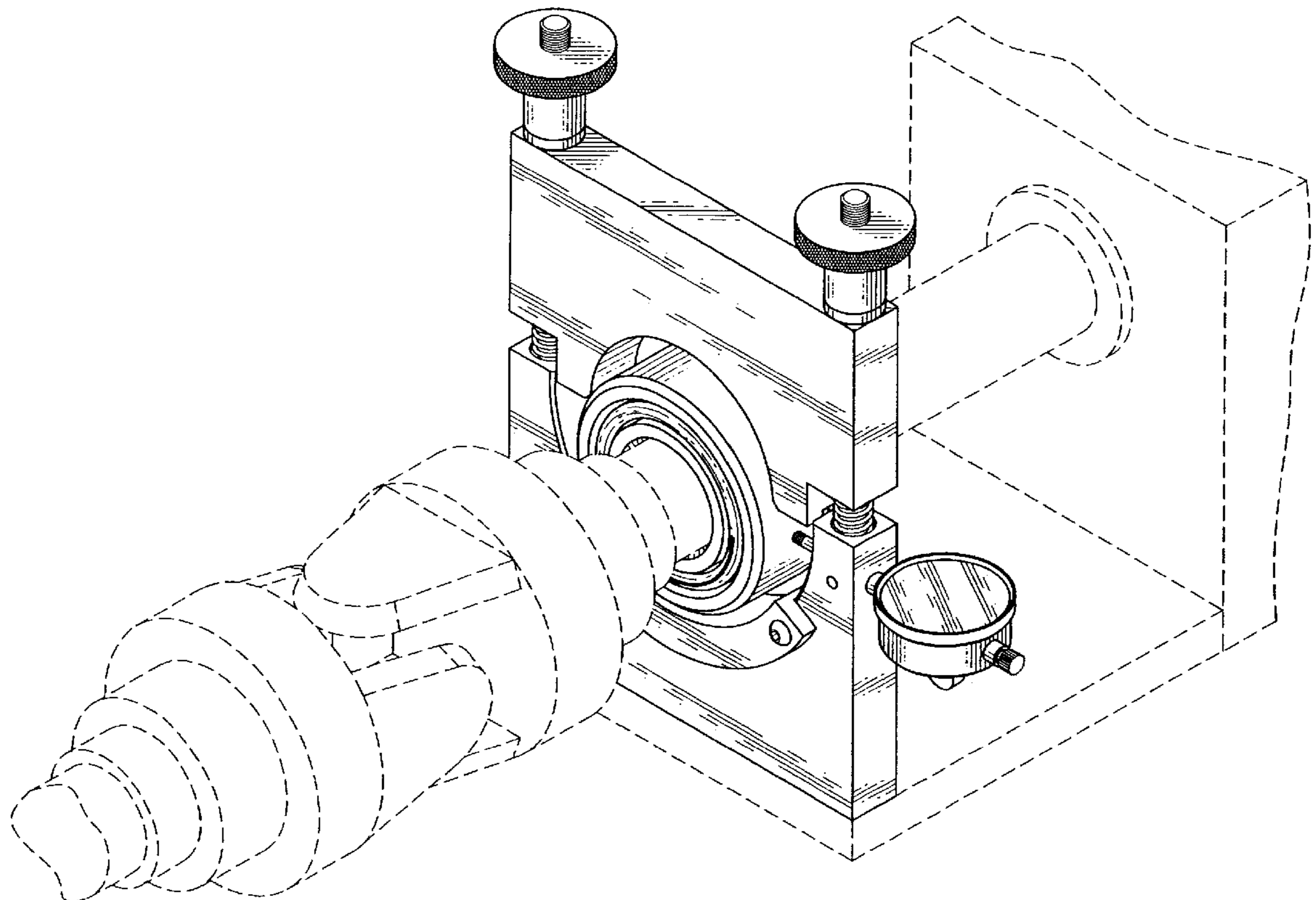

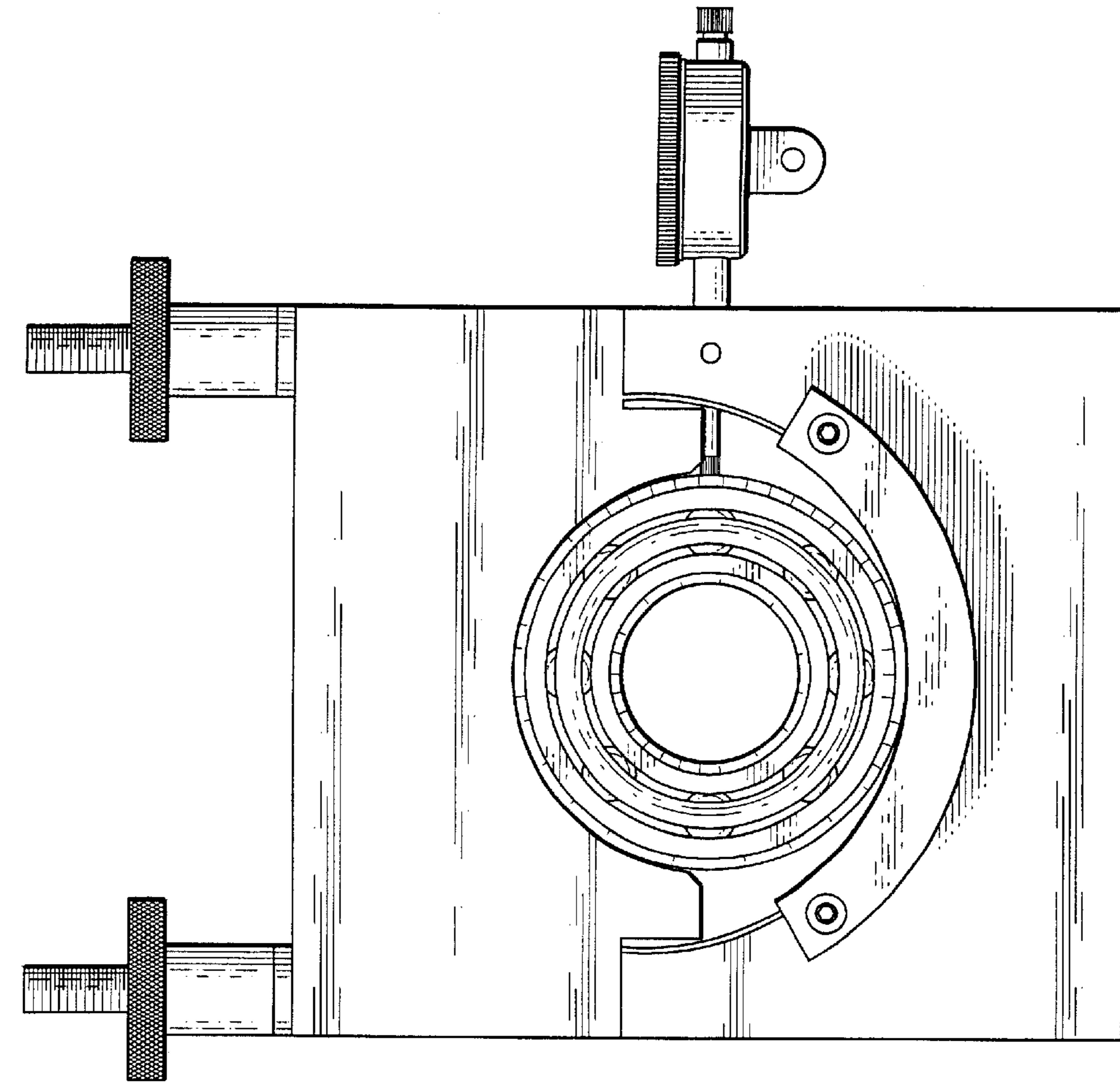

Fig. 2

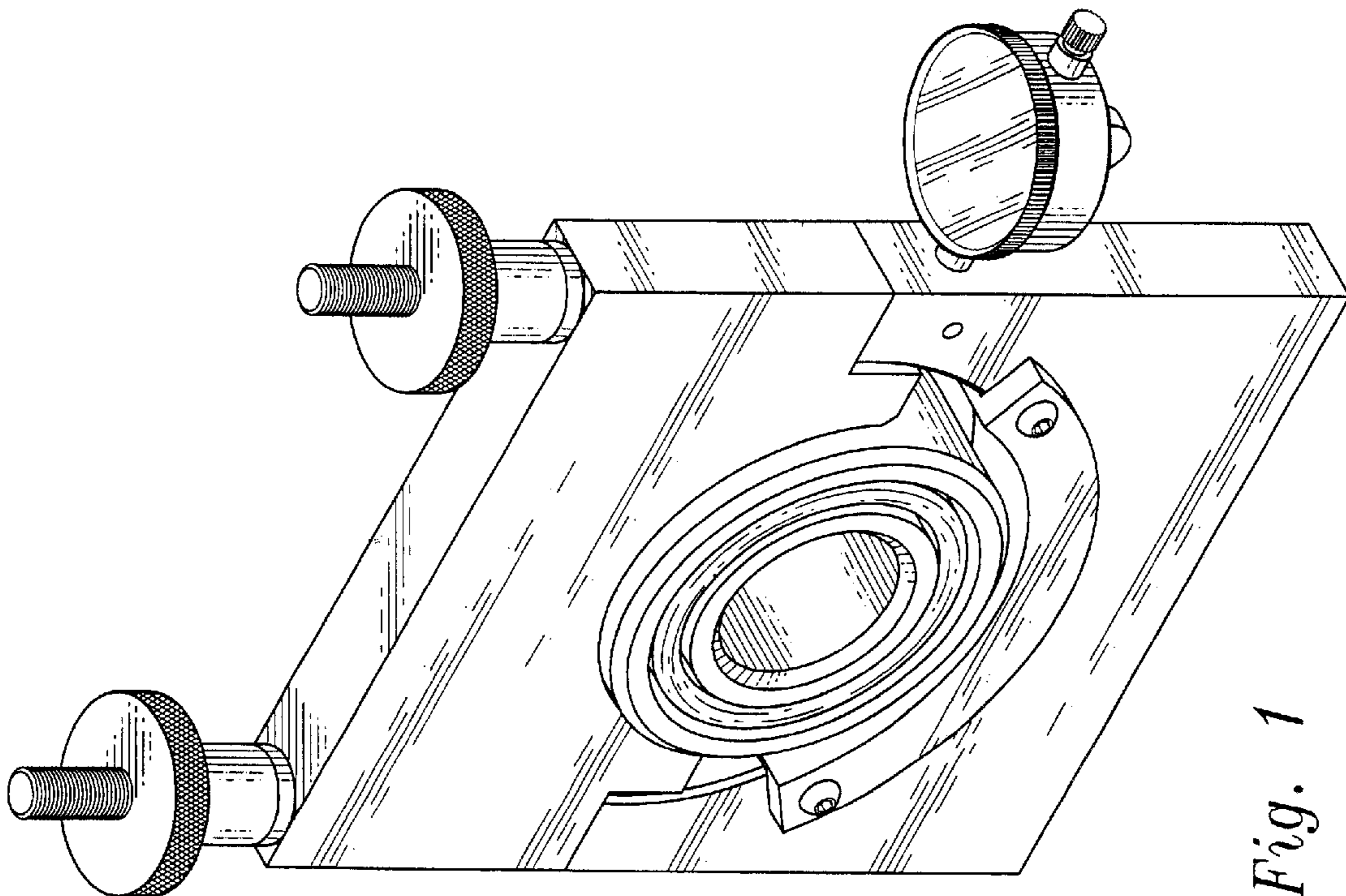

Fig. 1

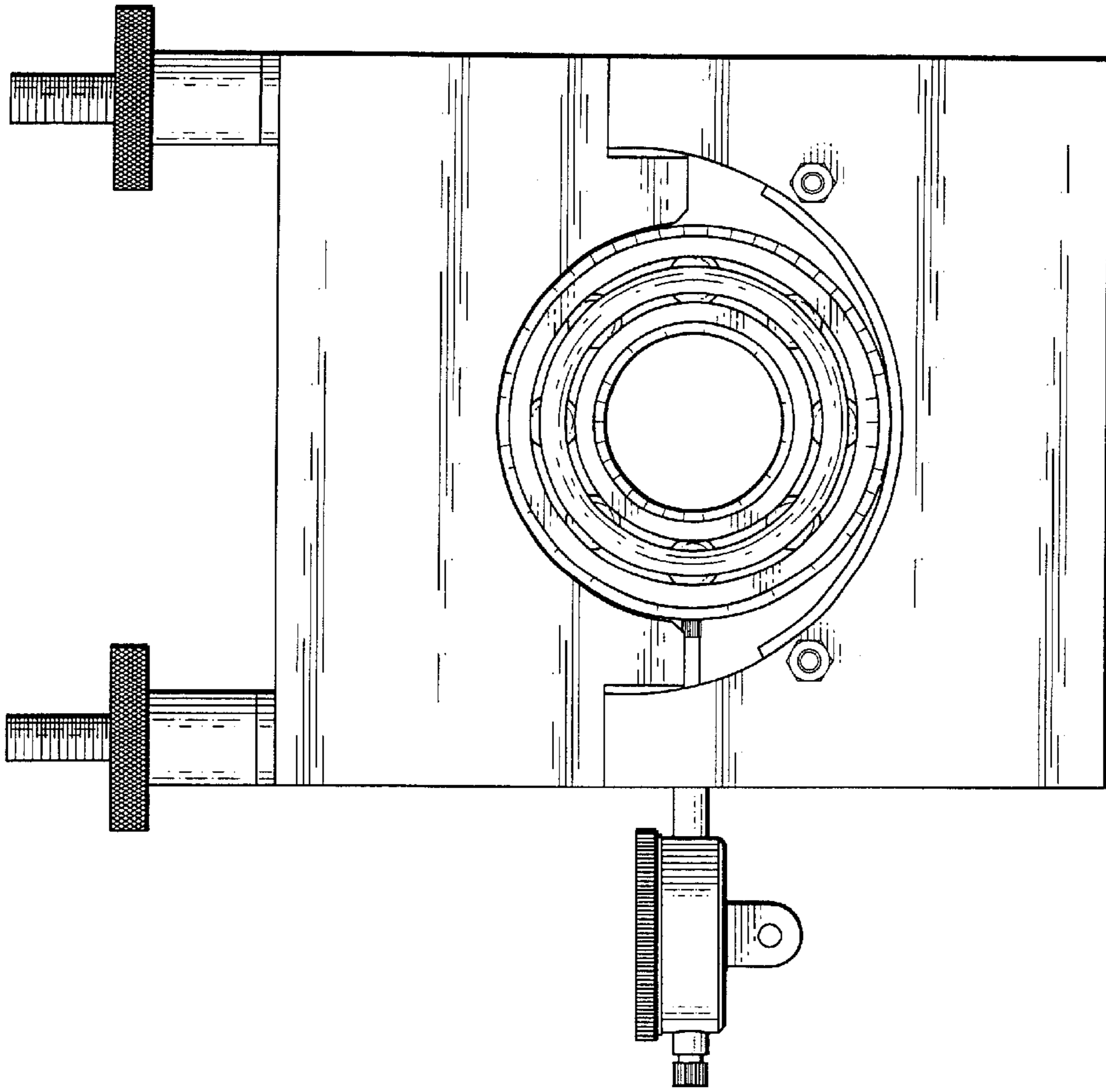

Fig. 3

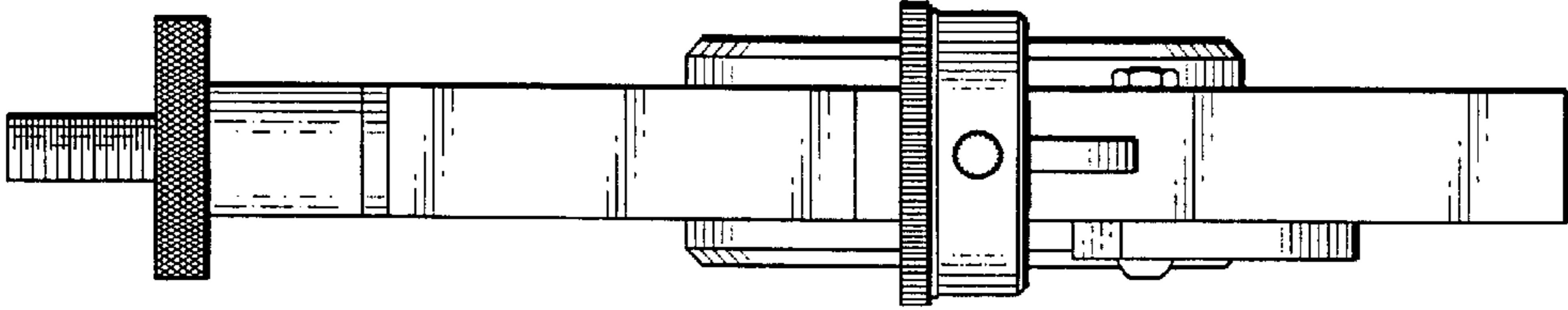

Fig. 4

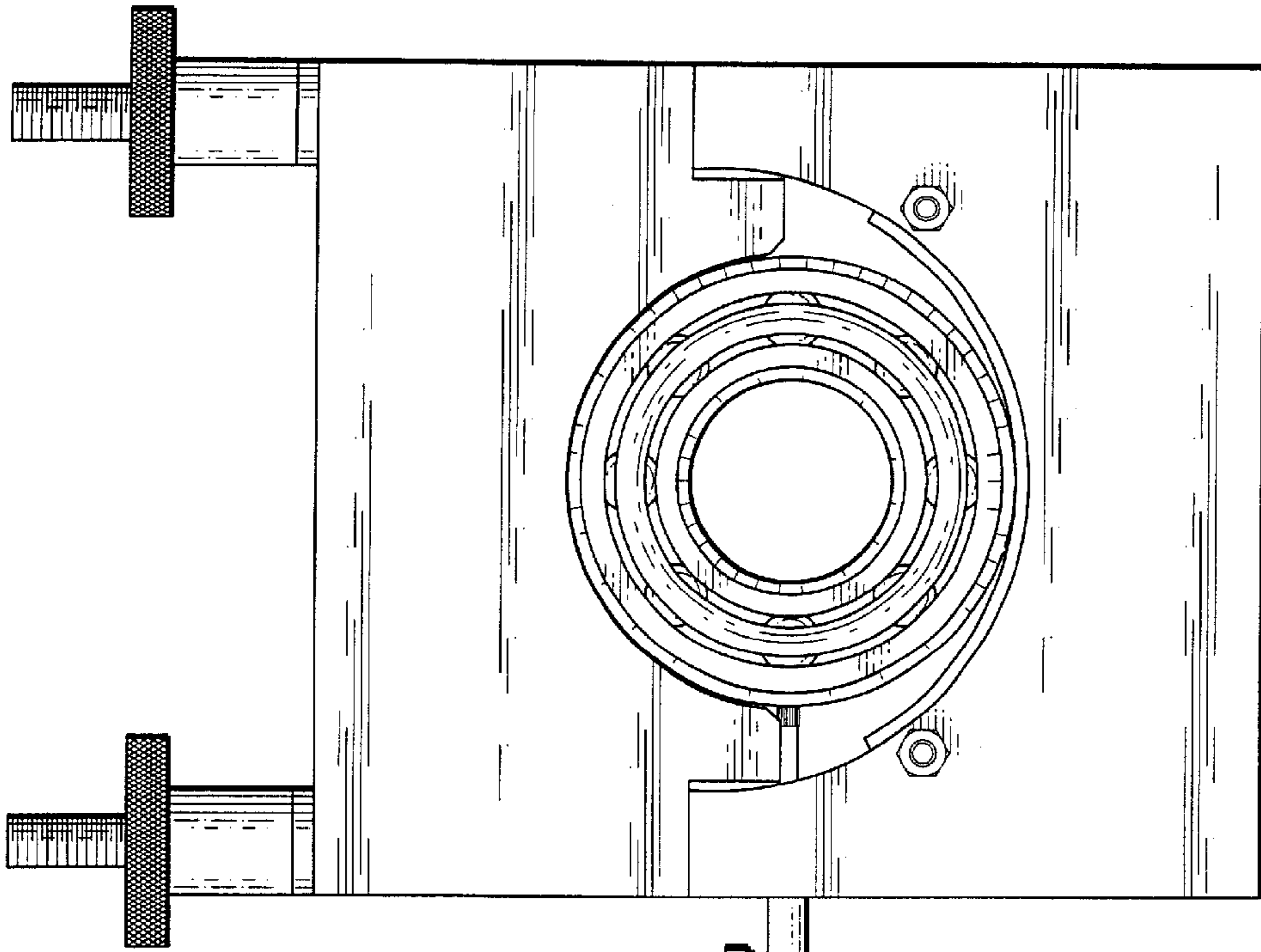

Fig. 5

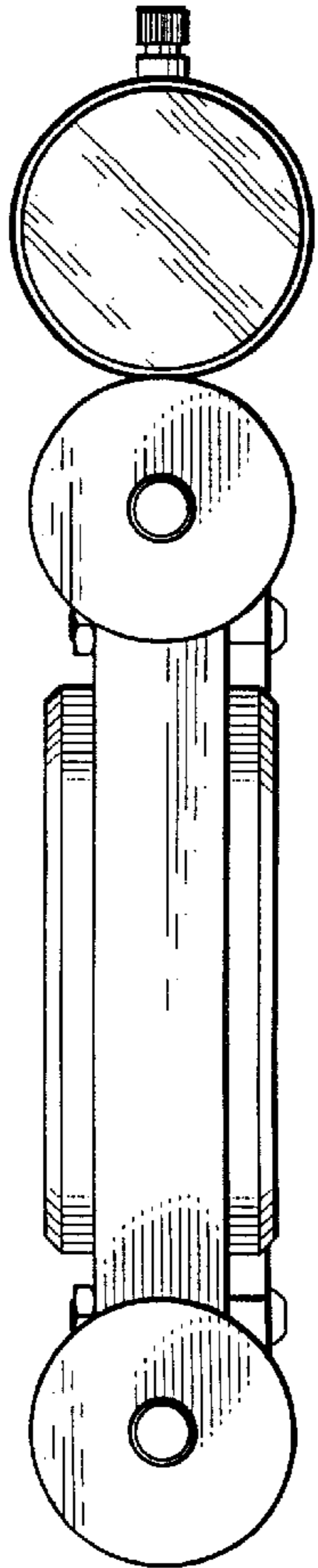

Fig. 6

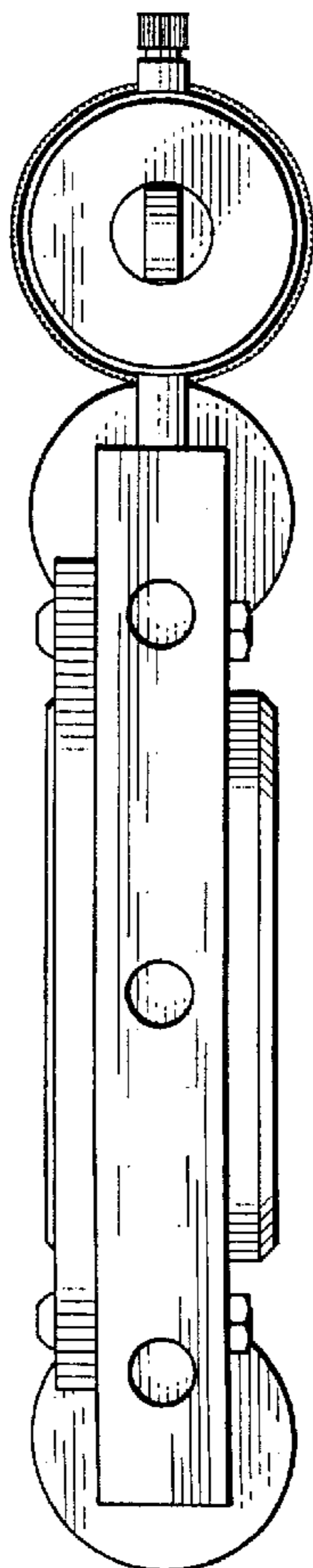

Fig. 7

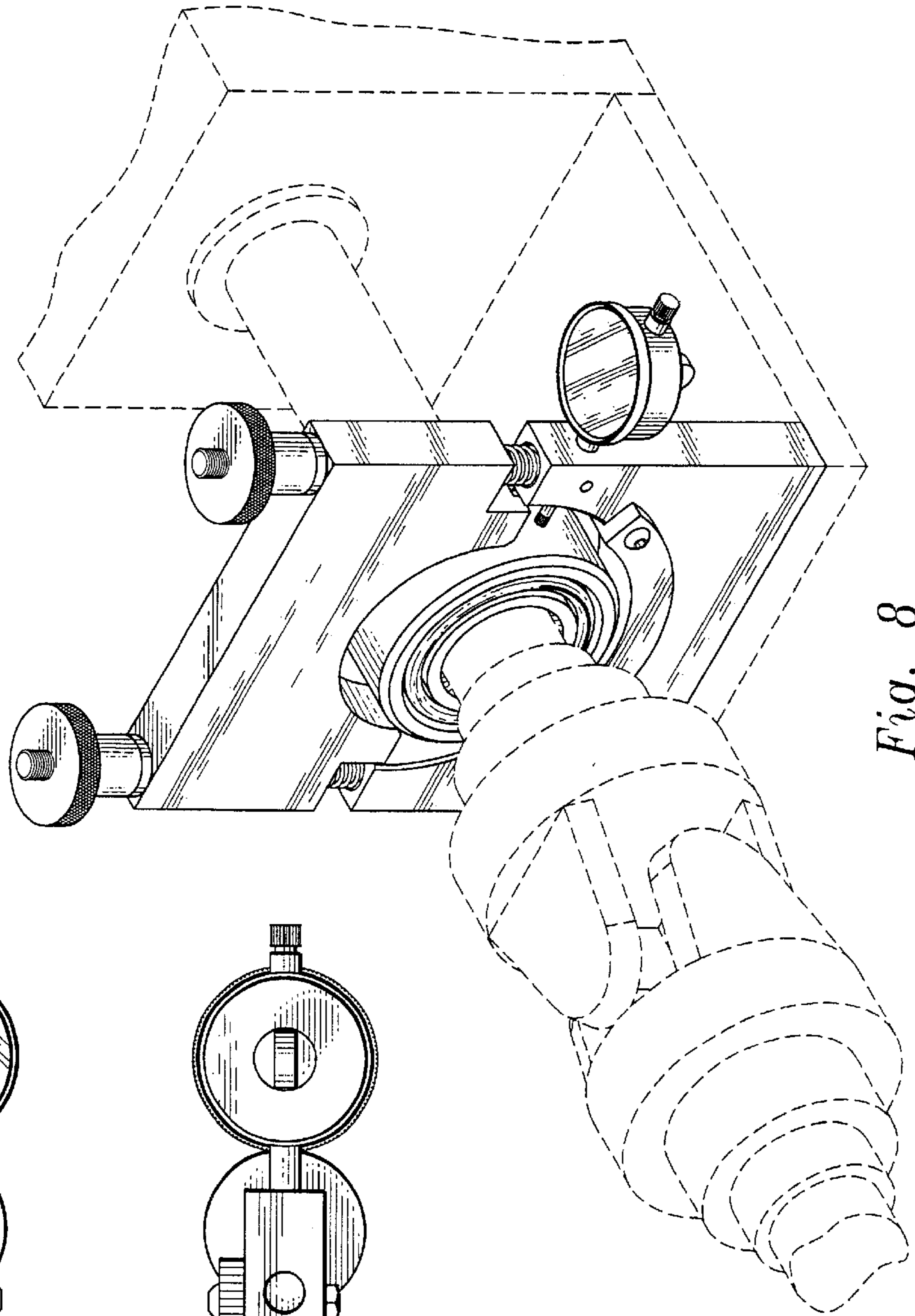

Fig. 8