



US00D462364S

(12) **United States Design Patent**
Fujita et al.

(10) **Patent No.:** **US D462,364 S**

(45) **Date of Patent:** **** Sep. 3, 2002**

(54) **COMPRESSOR FOR AIR CONDITIONERS OF VEHICLES**

(75) Inventors: **Masaaki Fujita; Masato Ogiwara,**
both of Isesaki (JP)

(73) Assignee: **Sanden Corporation,** Gunma (JP)

(**) Term: **14 Years**

(21) Appl. No.: **29/146,657**

(22) Filed: **Aug. 15, 2001**

(30) **Foreign Application Priority Data**

Feb. 19, 2001 (JP) 2001-008582

(51) **LOC (7) Cl.** **15-02**

(52) **U.S. Cl.** **D15/9**

(58) **Field of Search** D15/7-9; D23/325,
D23/354; 428/63, 259; 417/534, 536

(56) **References Cited**

U.S. PATENT DOCUMENTS

4,373,876 A	2/1983	Nemoto	
D282,471 S	* 2/1986	Bearint et al.	D15/9
D351,603 S	10/1994	Ikeda et al.	
D352,291 S	* 11/1994	Ikeda et al.	D15/7
D356,862 S	3/1995	Ito et al.	
D381,340 S	* 7/1997	Takenaka et al.	D15/9
D381,993 S	* 8/1997	Takenaka et al.	D15/9
D417,266 S	11/1999	Ito et al.	
D429,738 S	* 8/2000	Kayukawa et al.	D15/9
D435,856 S	* 1/2001	Kato	D15/9
D440,232 S	* 4/2001	Kou	D15/9
D441,377 S	* 5/2001	Kawaguchi et al.	D15/9
D441,378 S	* 5/2001	Kou	D15/9
D444,799 S	* 7/2001	Thomas, Jr. et al.	D15/9
D446,221 S	* 8/2001	Kanou et al.	D15/9

OTHER PUBLICATIONS

U.S. Design application Ser. No. 29/113,666, filed on Nov. 10, 1999.

U.S. Design application Ser. No. 29/145,206, filed on Jun. 19, 2001.

U.S. Design application Ser. No. 29/146,658, filed on Aug. 15, 2001.

U.S. Design application Ser. No. 29/146,659, filed on Aug. 15, 2001.

* cited by examiner

Primary Examiner—Ralf Seifert

(74) *Attorney, Agent, or Firm*—Baker Botts LLP

(57) **CLAIM**

The ornamental design for a compressor for air conditioners of vehicles, as shown and described.

DESCRIPTION

FIG. 1 is a front view of a compressor for air conditioner of vehicles, according to the design.

FIG. 2 is a rear view of the compressor, as shown in FIG. 1.

FIG. 3 is a right side view of the compressor, as shown in FIG. 1.

FIG. 4 is a left side view of the compressor, as shown in FIG. 1.

FIG. 5 is a top view of the compressor, as shown in FIG. 1.

FIG. 6 is a bottom view of the compressor, as shown in FIG. 1.

FIG. 7 is a front perspective view of the compressor of FIG. 1; and,

FIG. 8 is a rear perspective view of the compressor of FIG. 1.

It being understood that the broken lines are for illustrative purposes only.

1 Claim, 4 Drawing Sheets

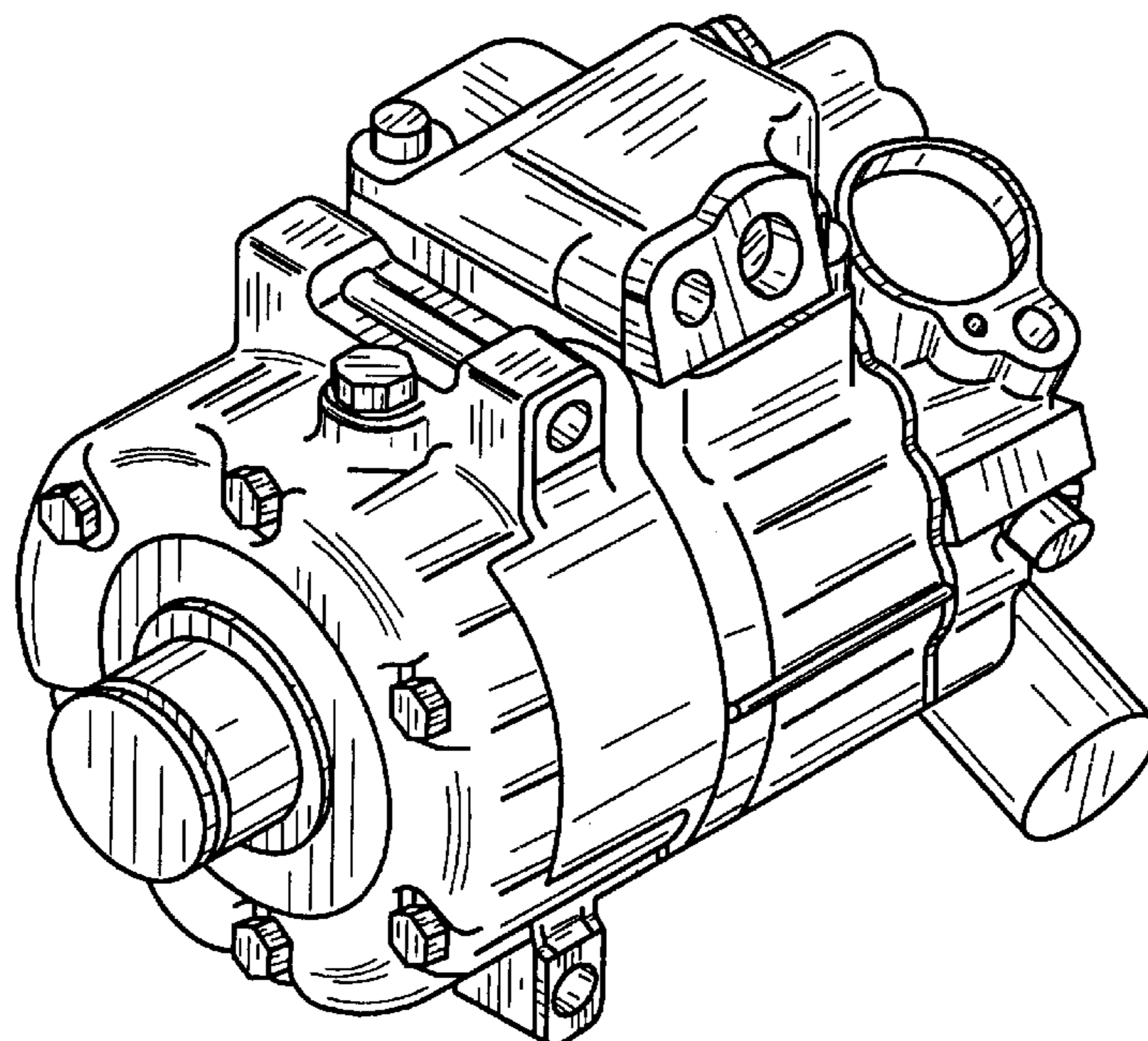

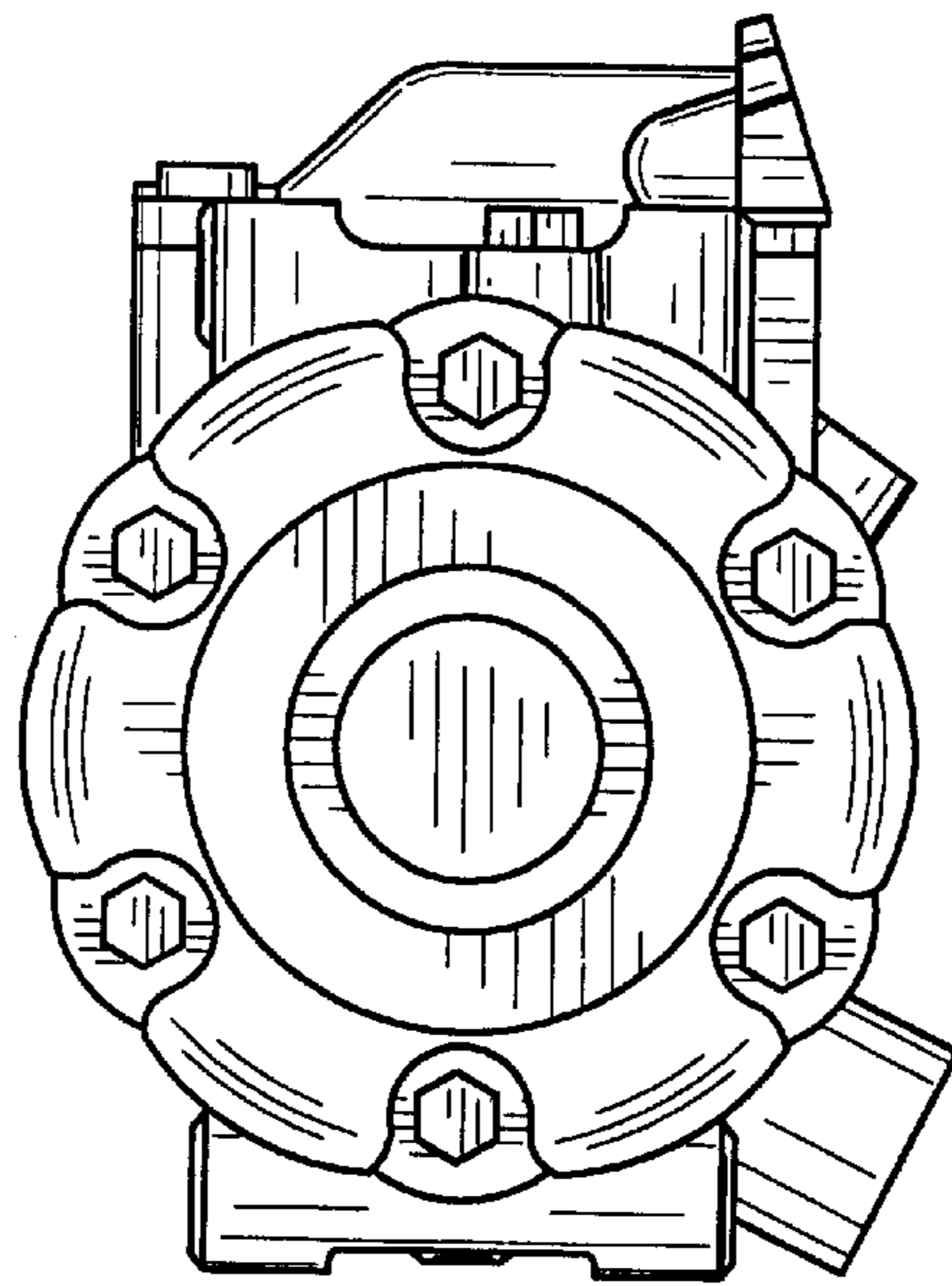

FIG. 1

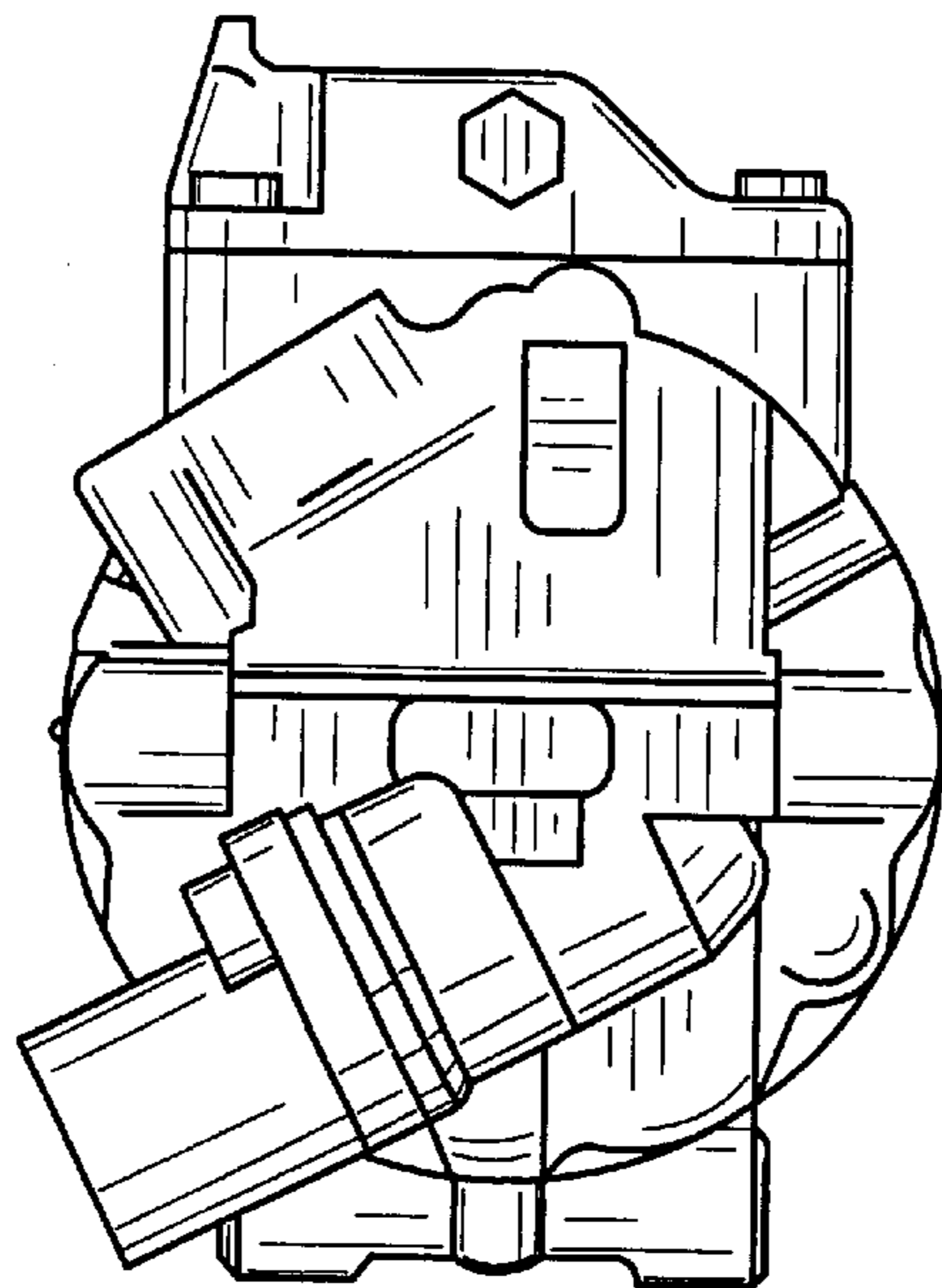

FIG. 2

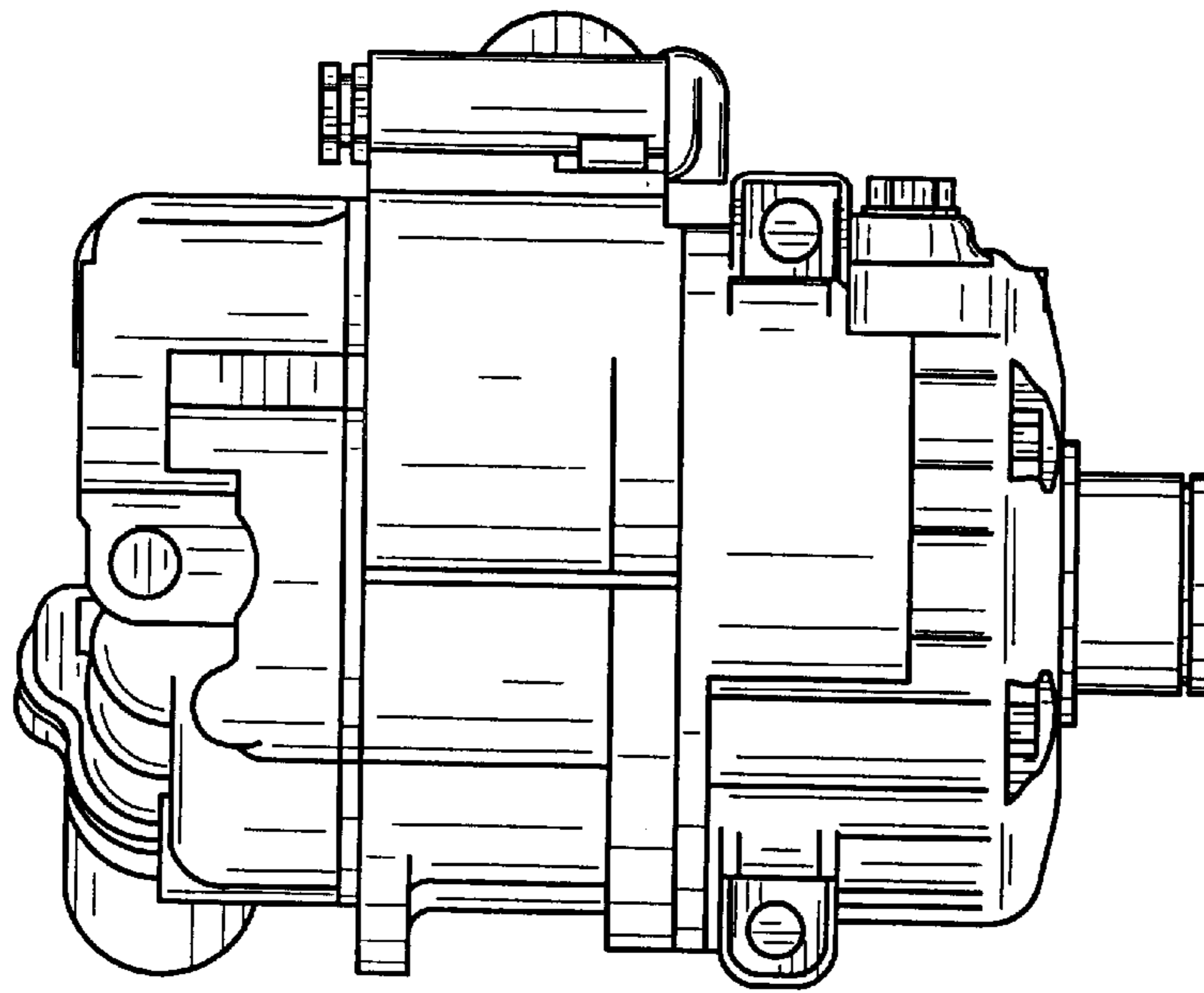

FIG. 3

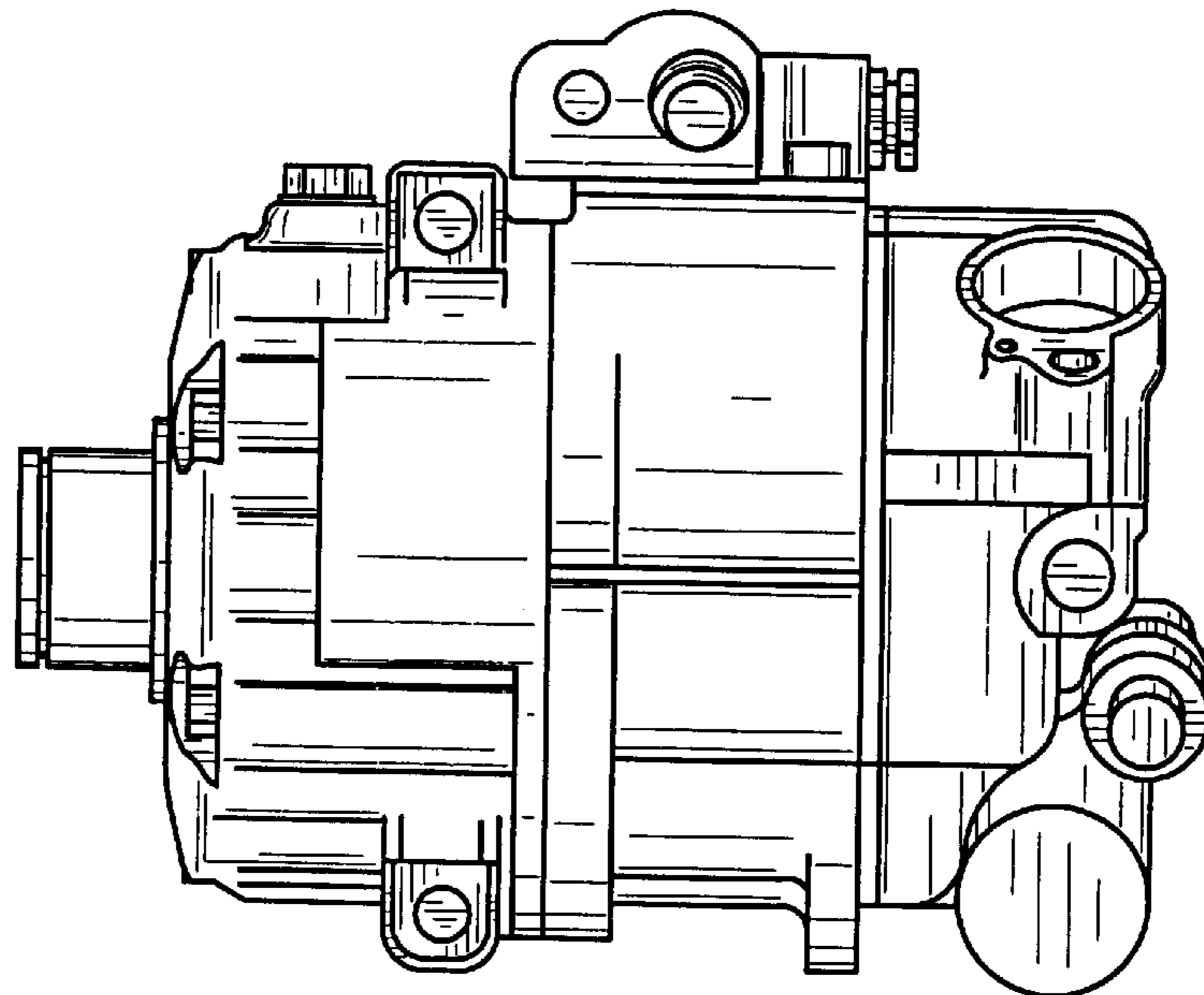

FIG. 4

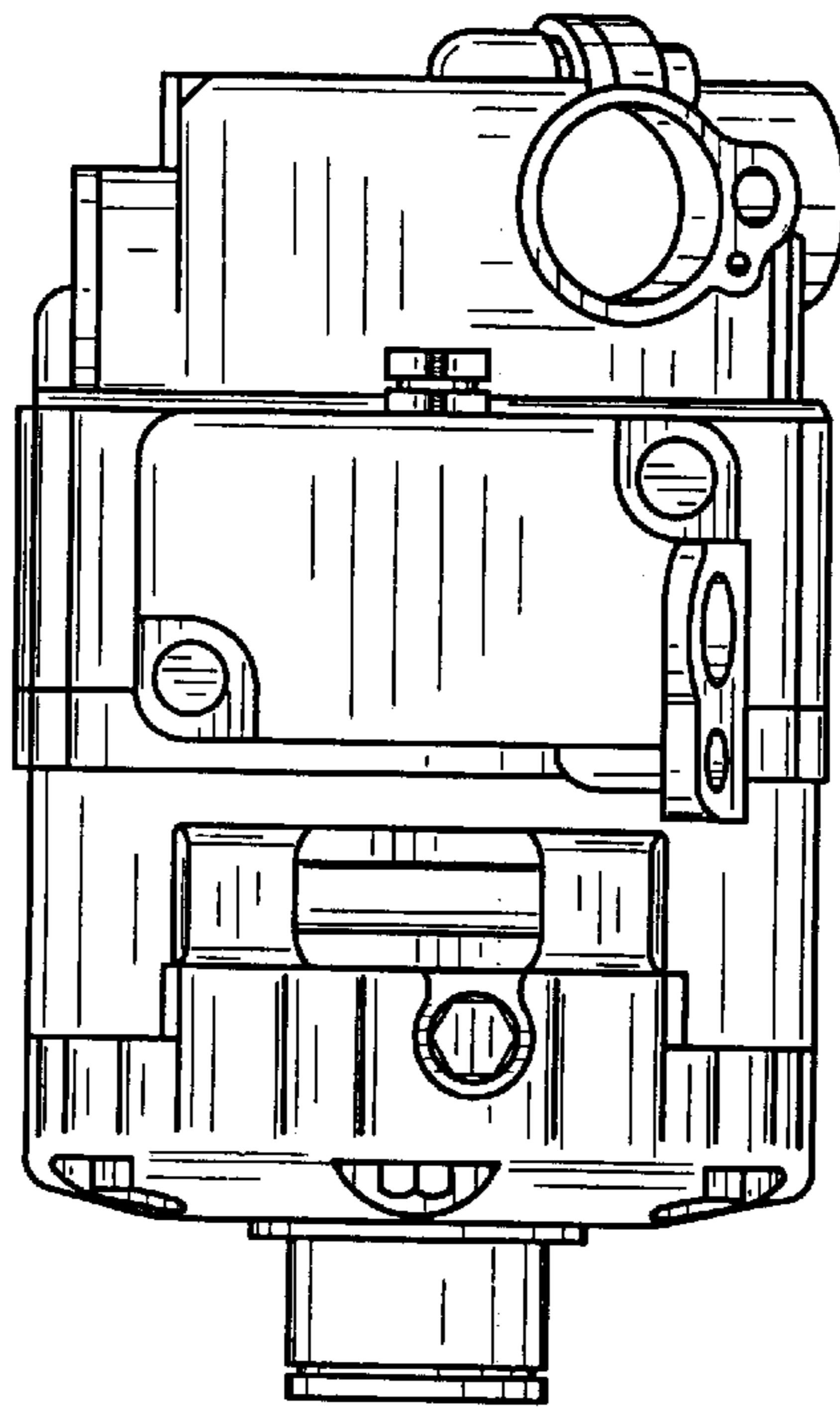

FIG. 5

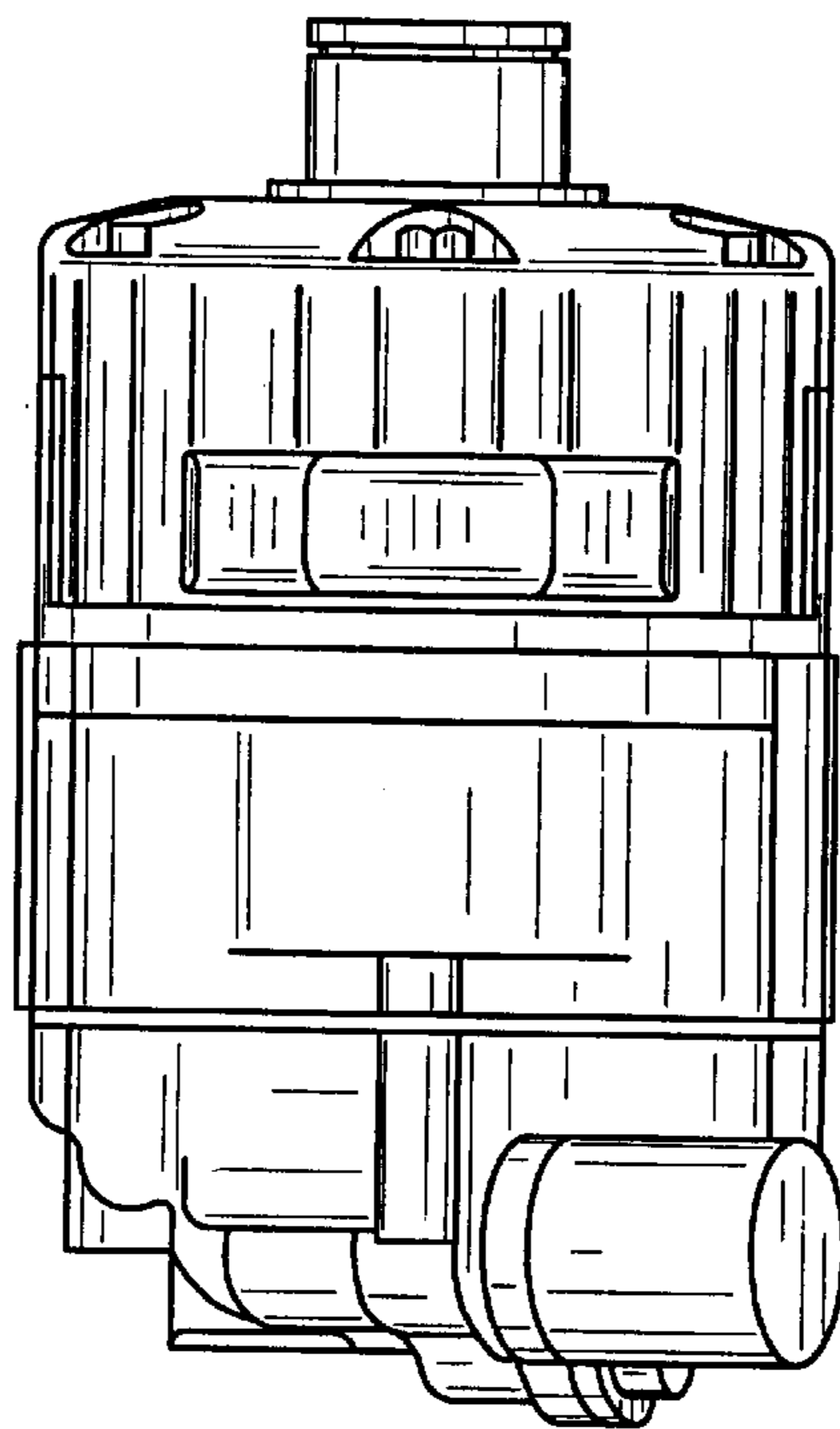

FIG. 6

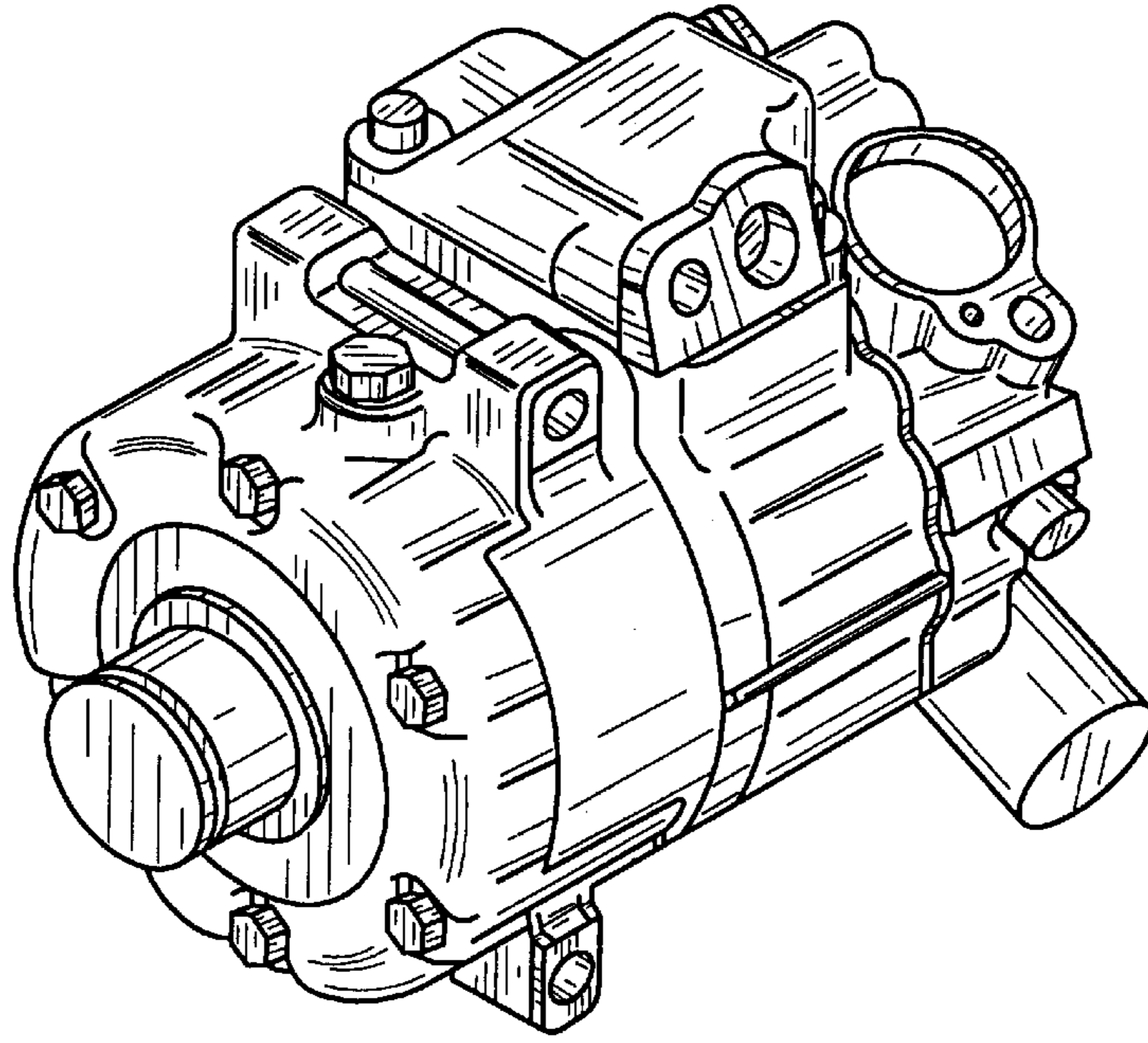

FIG. 7

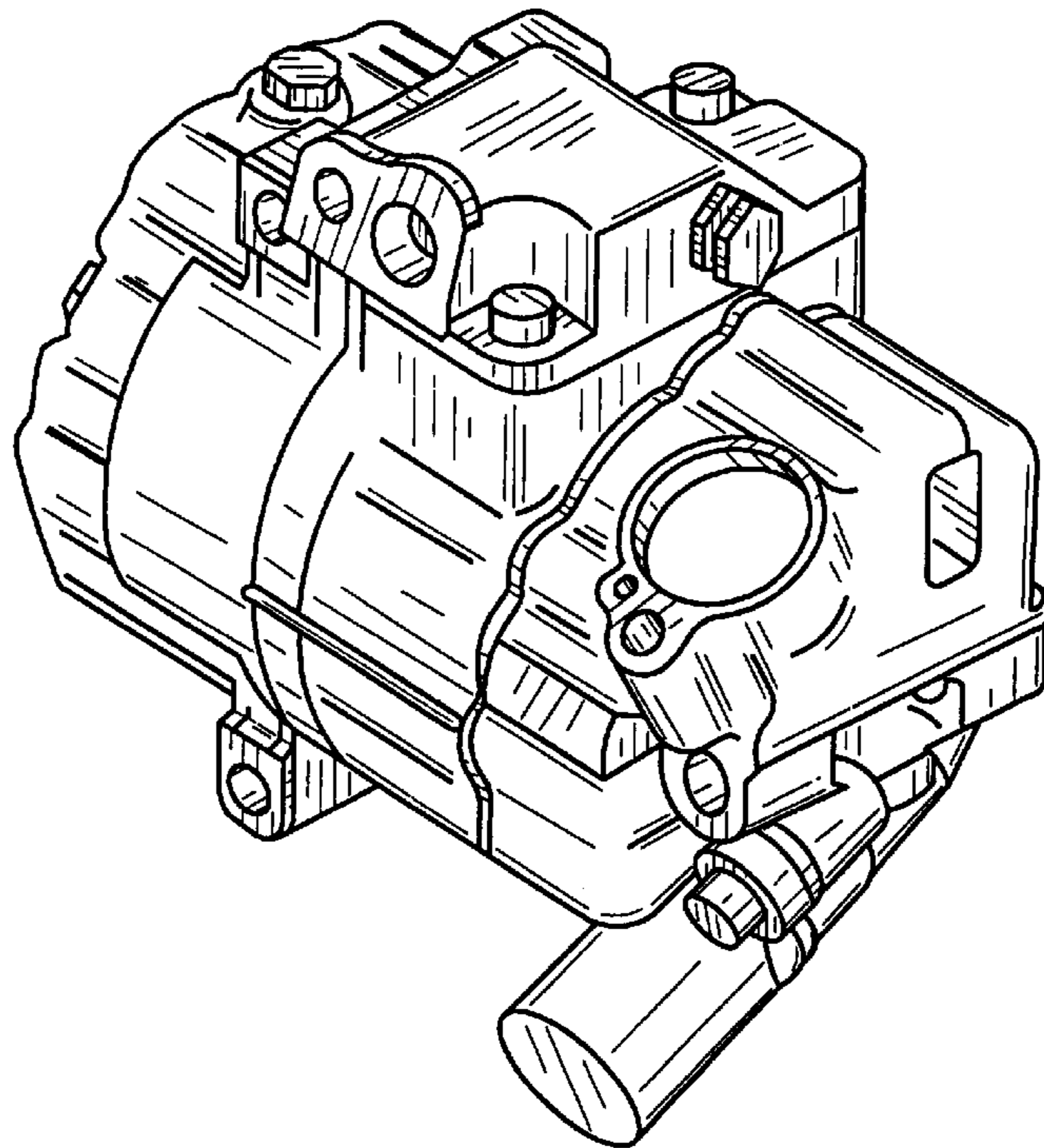

FIG. 8