

US00D462300S

(12) **United States Design Patent** (10) **Patent No.:** **US D462,300 S**
Cerny, Jr. et al. (45) **Date of Patent:** **** Sep. 3, 2002**

(54) **VEHICLE CHASSIS SURFACE**

Primary Examiner—Melody N. Brown

(75) Inventors: **John Robert Cerny, Jr.; Mohamad Samih El-Zein**, both of Bettendorf, IA (US); **Harold Eugene Krause**, Milan; **Richard Lane Hockenberry**, Viola, both of IL (US)

(57) **CLAIM**

The ornamental design for a vehicle chassis surface, as shown and described.

(73) Assignee: **Deere & Company**, Moline, IL (US)

DESCRIPTION

(**) Term: **14 Years**

(21) Appl. No.: **29/147,791**

FIG. 1 is an elevated left front perspective view of a vehicle chassis surface showing a first embodiment of our new design, the broken line showings of the front, mid and rear compartments being for illustrative purposes only, and forming no part of the claimed design.

(22) Filed: **Sep. 4, 2001**

FIG. 2 is an elevated rear left perspective view of the vehicle chassis surface design of FIG. 1.

Related U.S. Application Data

(62) Division of application No. 29/118,944, filed on Feb. 18, 2000.

FIG. 3 is a plan view of the vehicle chassis surface design of FIG. 1.

(51) **LOC (7) Cl.** **12-08**

FIG. 4 is a left side view of the vehicle chassis surface design of FIG. 1.

(52) **U.S. Cl.** **D12/86**

FIG. 5 is a right side view of the vehicle chassis surface design of FIG. 1.

(58) **Field of Search** D12/86, 16, 15, D12/14, 107; 296/185

FIG. 6 is a front view of the vehicle chassis surface design of FIG. 1.

(56) **References Cited**

FIG. 7 is a rear view of the vehicle chassis surface design of FIG. 1.

U.S. PATENT DOCUMENTS

D311,921 S	11/1990	Popelier et al.	D15/15
5,174,627 A	12/1992	Cleereman et al.	296/187
D338,473 S	8/1993	Patterson et al.	D15/17
5,238,267 A	8/1993	Hutchison et al.	280/781
5,314,230 A	5/1994	Hutchison et al.	296/203
5,558,368 A	9/1996	Cerny et al.	280/781
D395,023 S	6/1998	Hikida	D12/16
D441,320 S	5/2001	Kehr	D12/16
D451,050 S	* 11/2001	Cerny, Jr. et al.	D12/86

FIG. 8 is an elevated left front perspective view of a vehicle chassis surface showing a second embodiment of our new design, the broken line showings of the front, mid and rear compartments being for illustrative purposes only, and forming no part of the claimed design.

OTHER PUBLICATIONS

Yamaha Motor Corp., Yamaha brochure, 2 pages, date of publication—unknown, published in U.S.A.

FIG. 9 is an elevated rear left perspective view of the vehicle chassis surface design of FIG. 8.

Lamborghini, Golf Cart brochure, 2 pages, dated Nov. 1997, published in Italy.

FIG. 10 is a plan view of the vehicle chassis surface design of FIG. 8.

FIG. 11 is a left side view of the vehicle chassis surface design of FIG. 8.

FIG. 12 is a right side view of the vehicle chassis surface design of FIG. 8.

FIG. 13 is a front view of the vehicle chassis surface design of FIG. 8; and,

FIG. 14 is a rear view of the vehicle chassis surface design of FIG. 8.

(List continued on next page.)

1 Claim, 10 Drawing Sheets

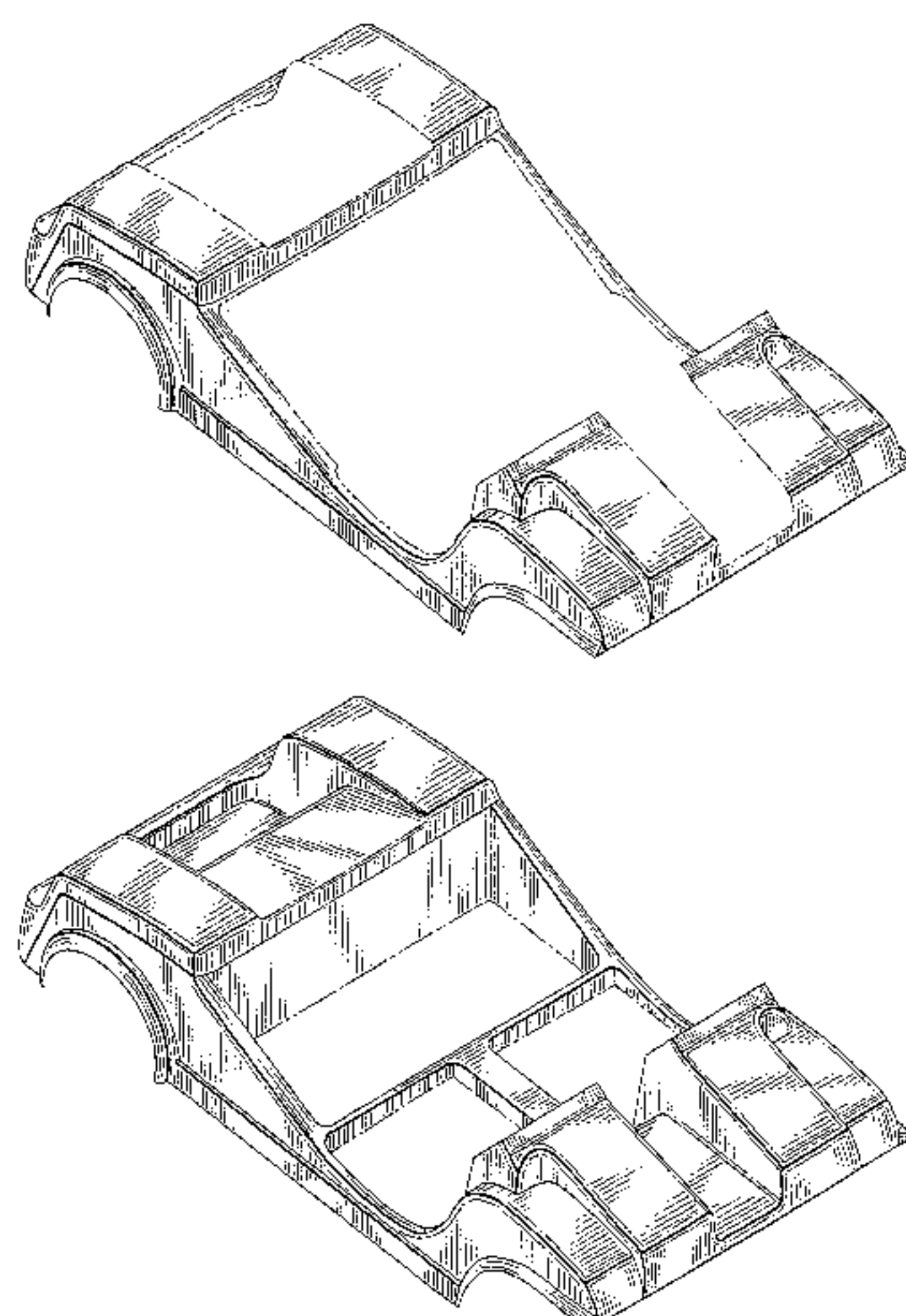

OTHER PUBLICATIONS

Shuttlecraft USA Inc., The Golf Car That Evolved From Space Age Technology brochure, 2 pages, dated Feb. 1988, published in U.S.A.

Yamaha Motor Corporation, Pro4 Utility Products brochure, 2 pages, date of publication—1989, published in U.S.A.

John Deere, John Deere Gator® 6×4 and 4×2 Utility Vehicles brochure, 12 pages, date of publication—Mar. 1993, published in U.S.A.

Club Car Inc., Drive It To Work brochure, 2 pages, dated Feb. 1994, published in U.S.A.

Kawasaki Motors Corp., Mule 2010/1000 brochure, 2 pages, date of publication—1990, published in Japan.

Ransomes Cushman Ryan, Cushman Hawk brochure, 2 pages, date of publication—1996, published in U.S.A.

E-Z-Go Textron, E-Z-Go brochure, 2 pages, date of publication—Jul. 1986, published in U.S.A.

Club Car Inc., Club Car brochure, 2 pages, date of publication—unknown, published in U.S.A.

* cited by examiner

Fig. 1

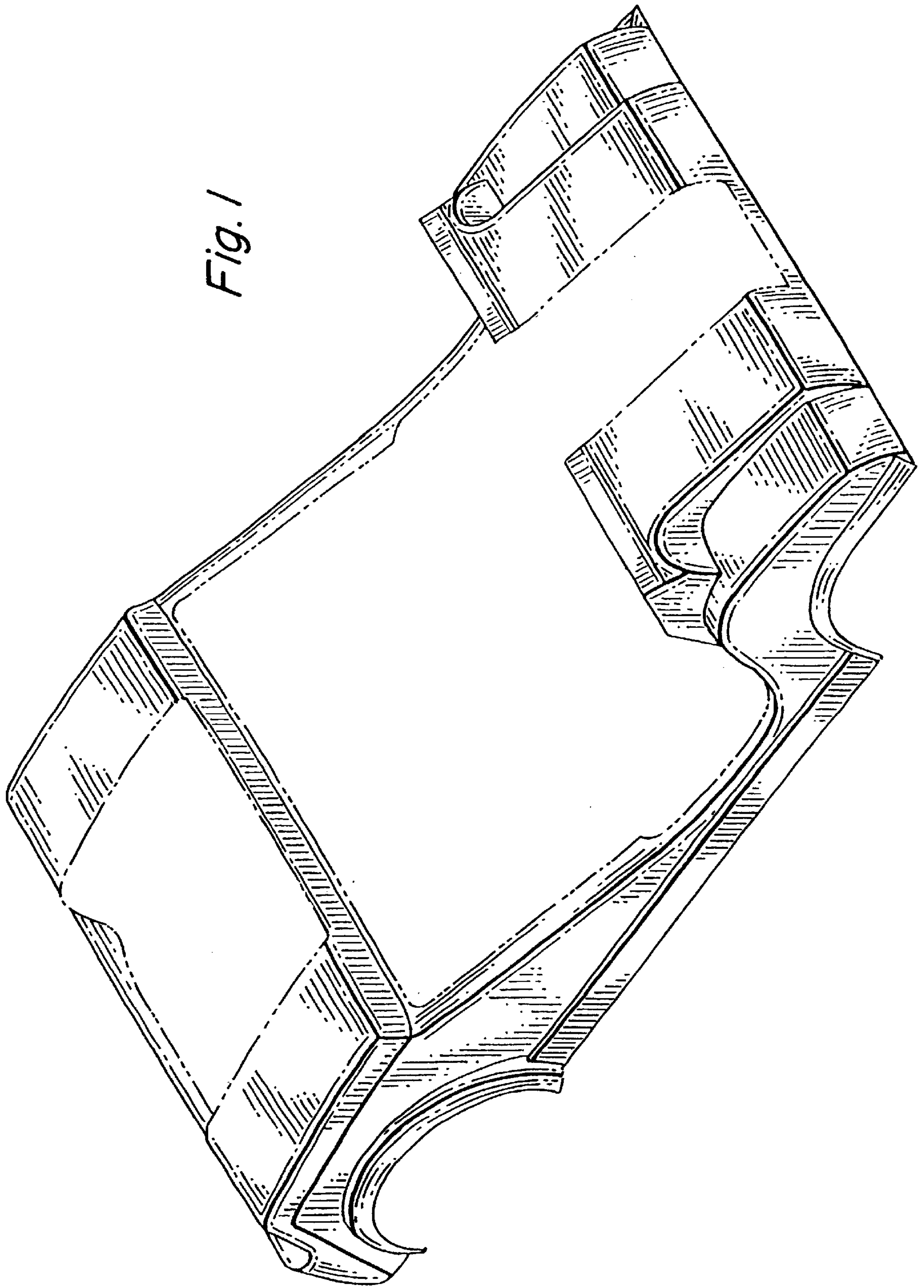

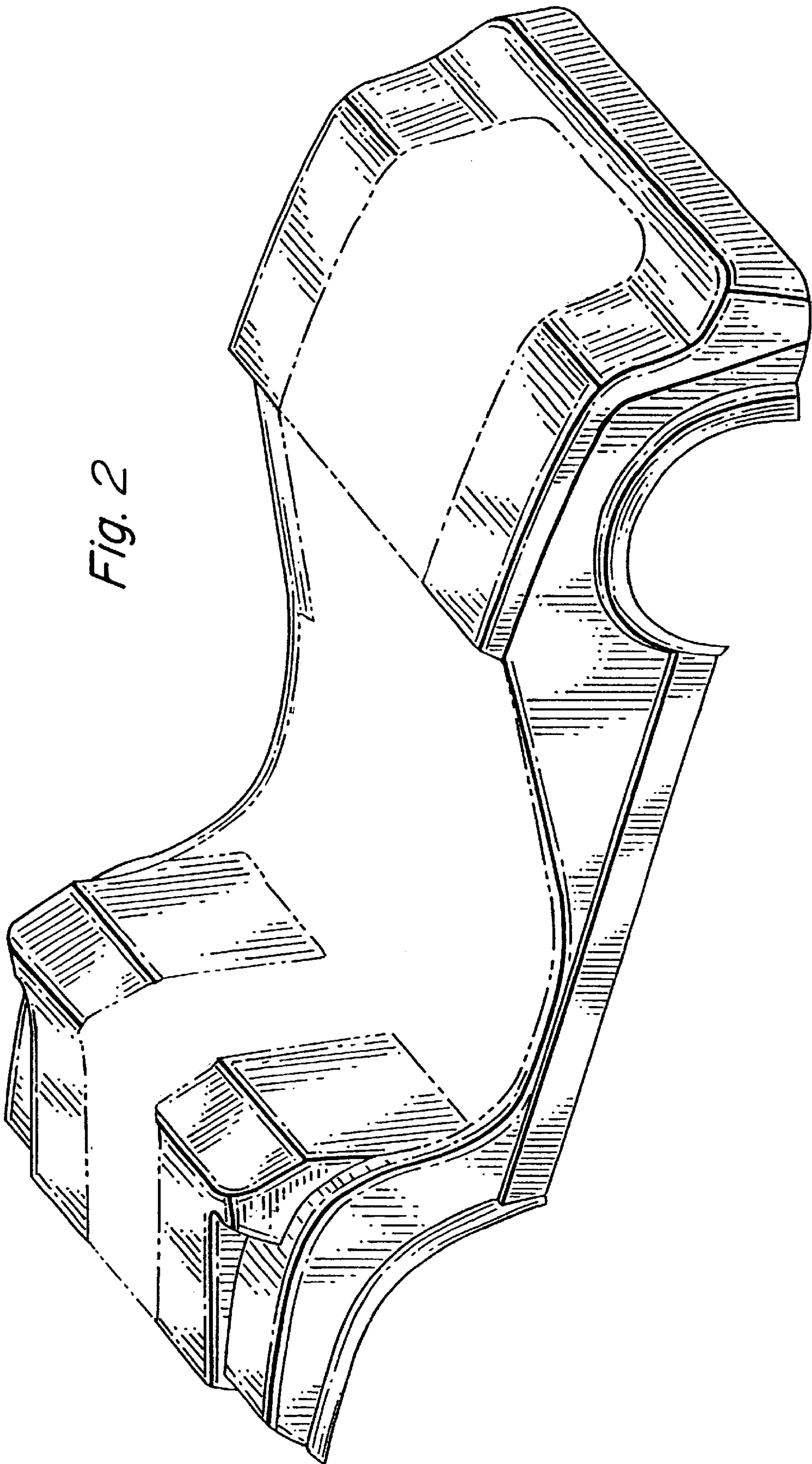

Fig. 2

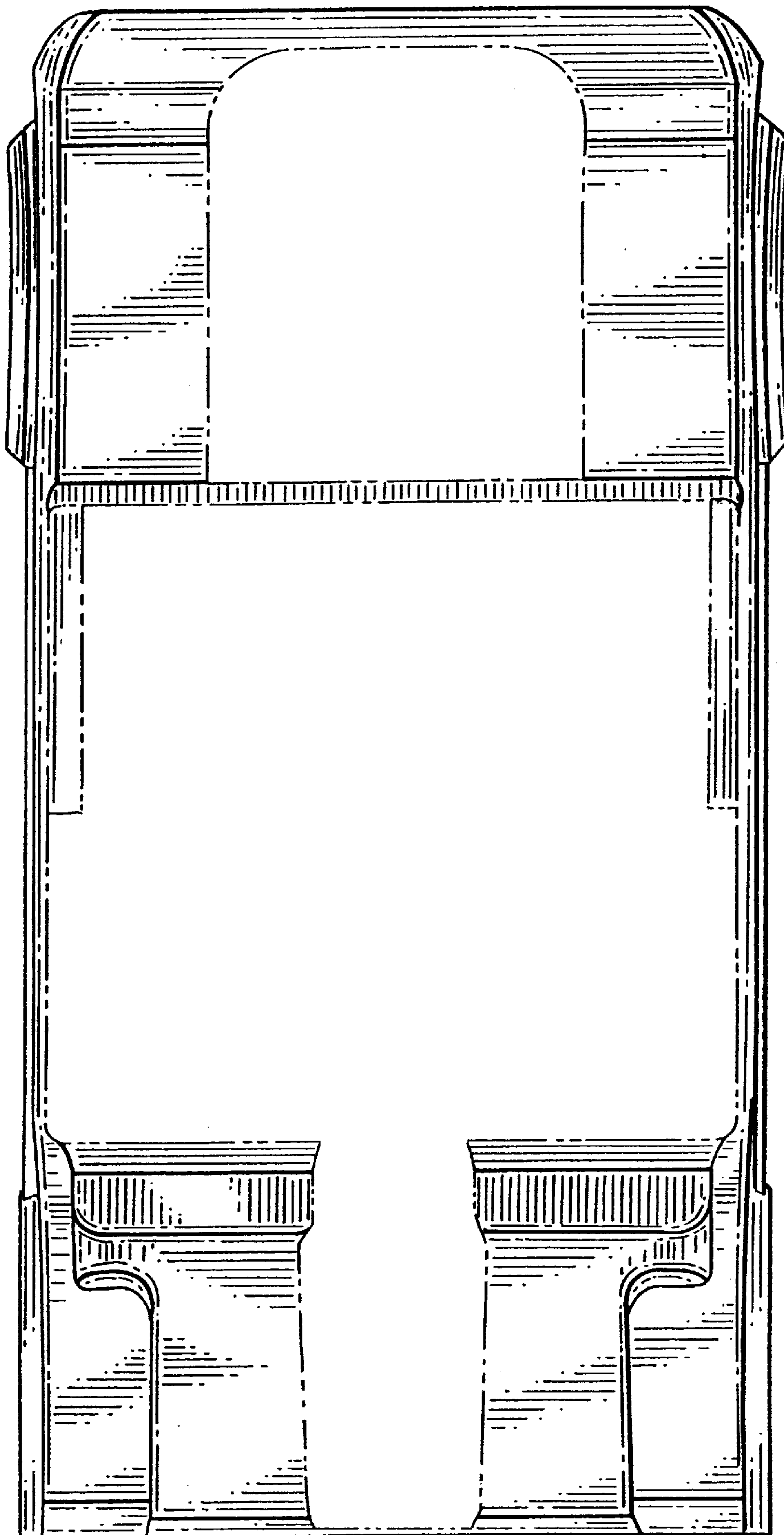

Fig. 3

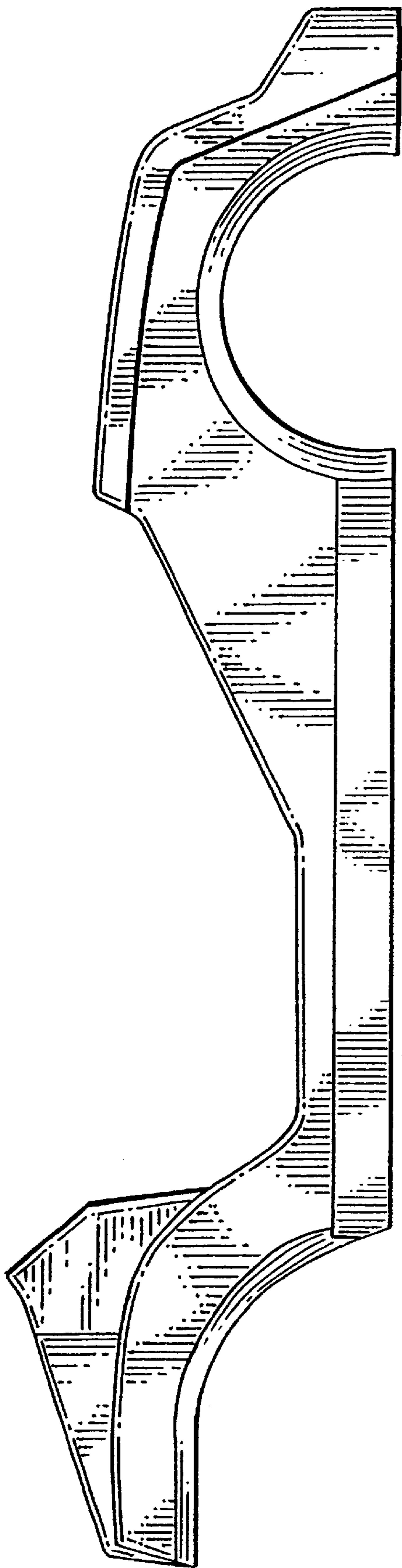

Fig. 4

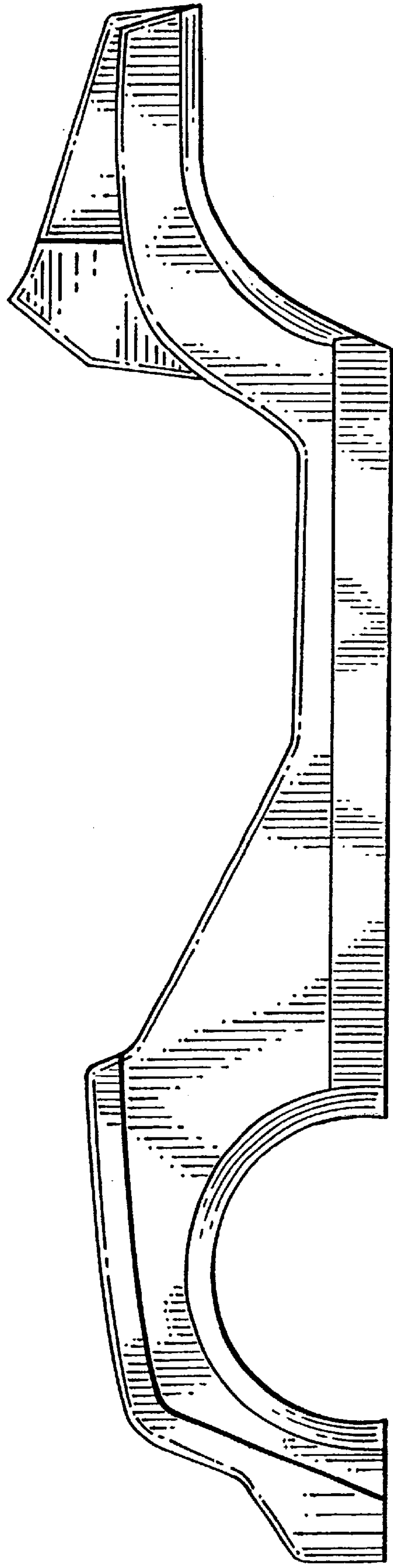

Fig. 5

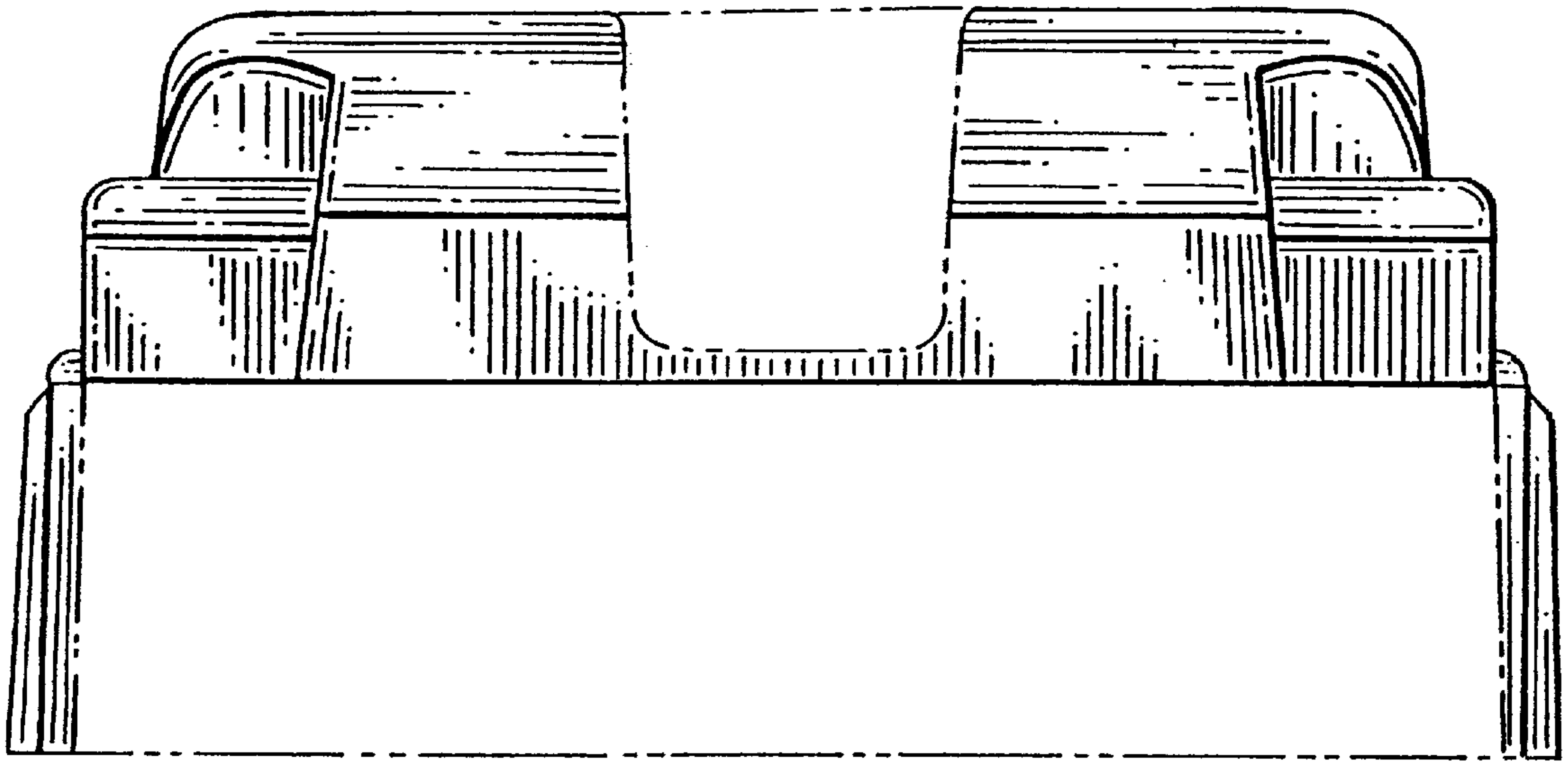

Fig. 6

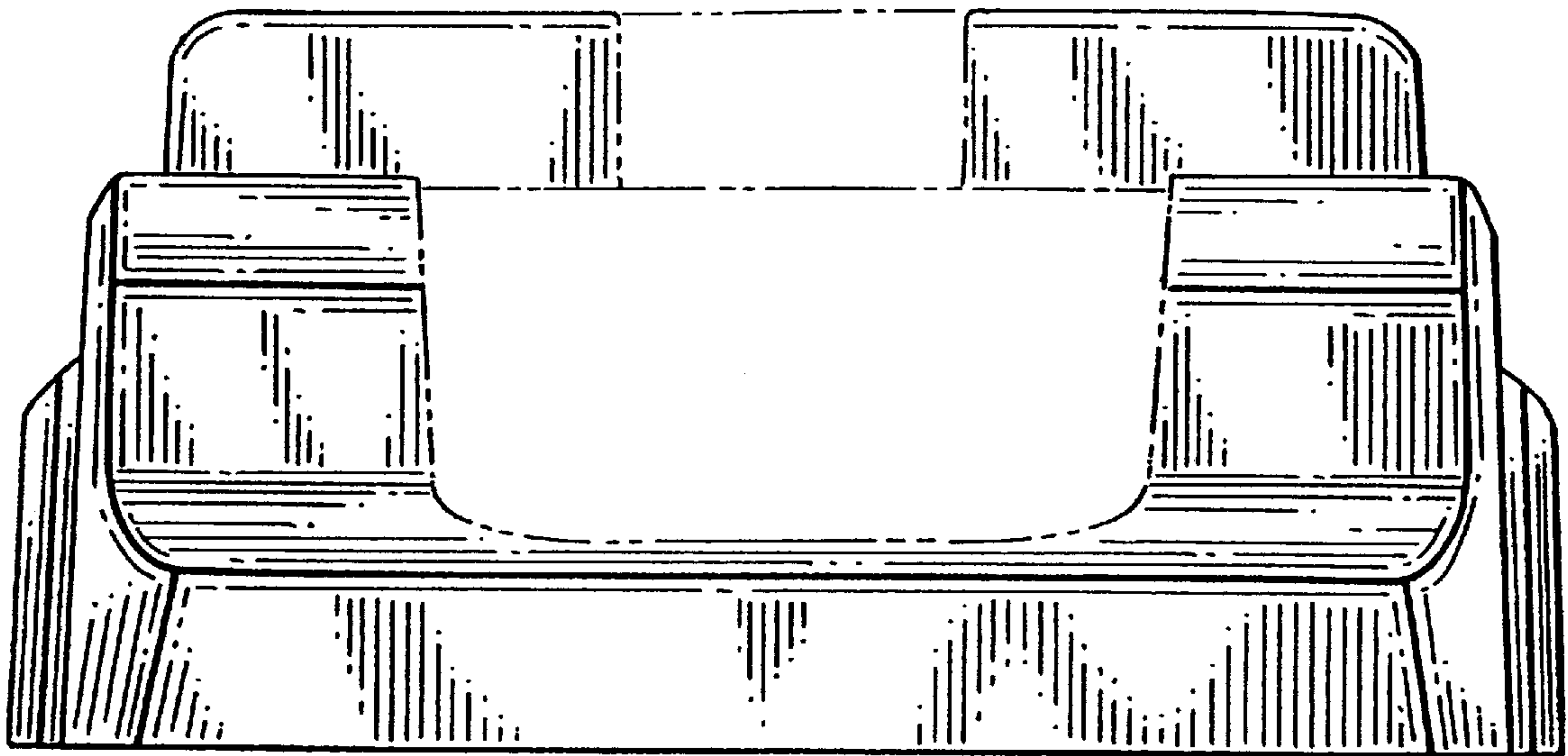
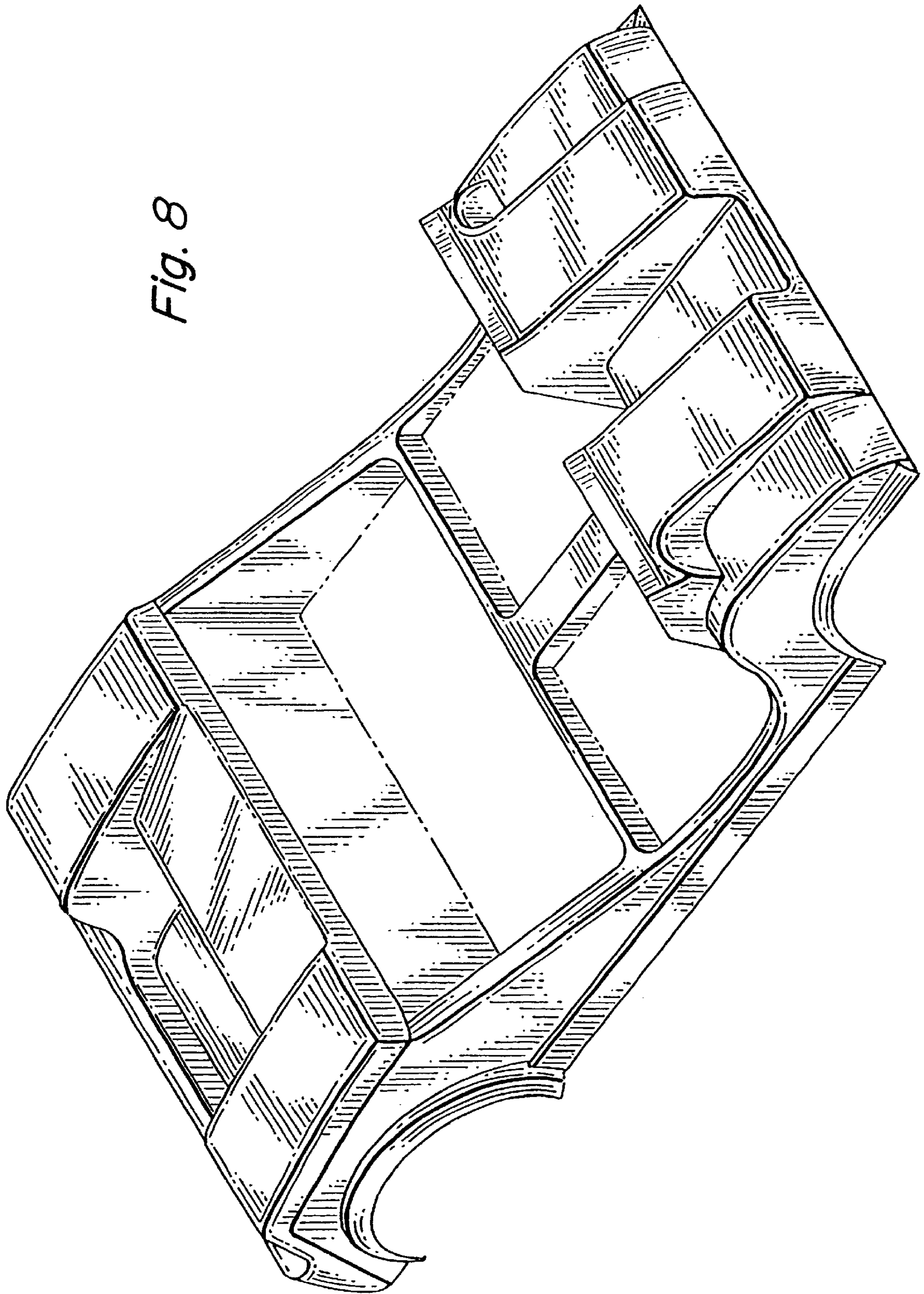

Fig. 7

Fig. 8



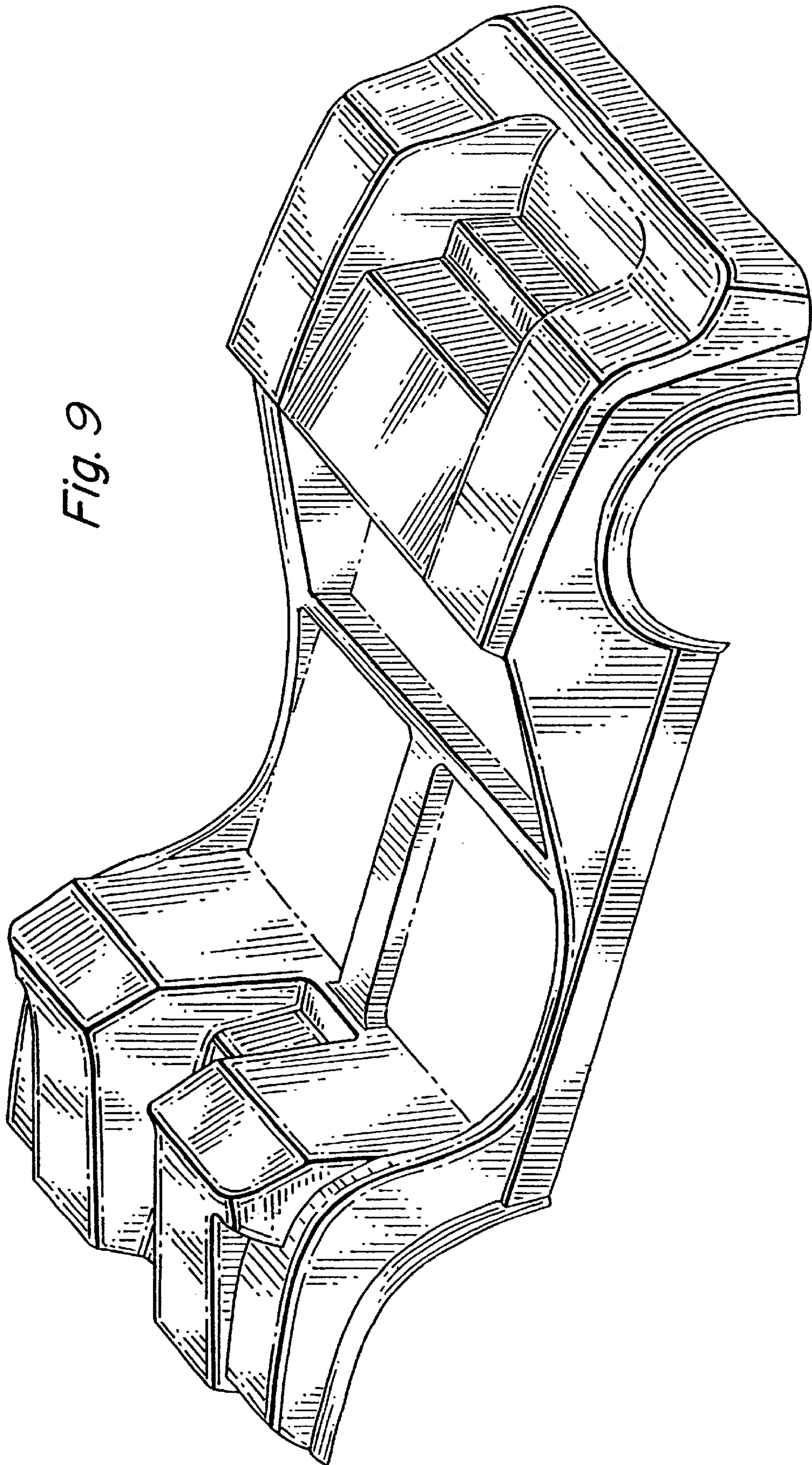

Fig. 9

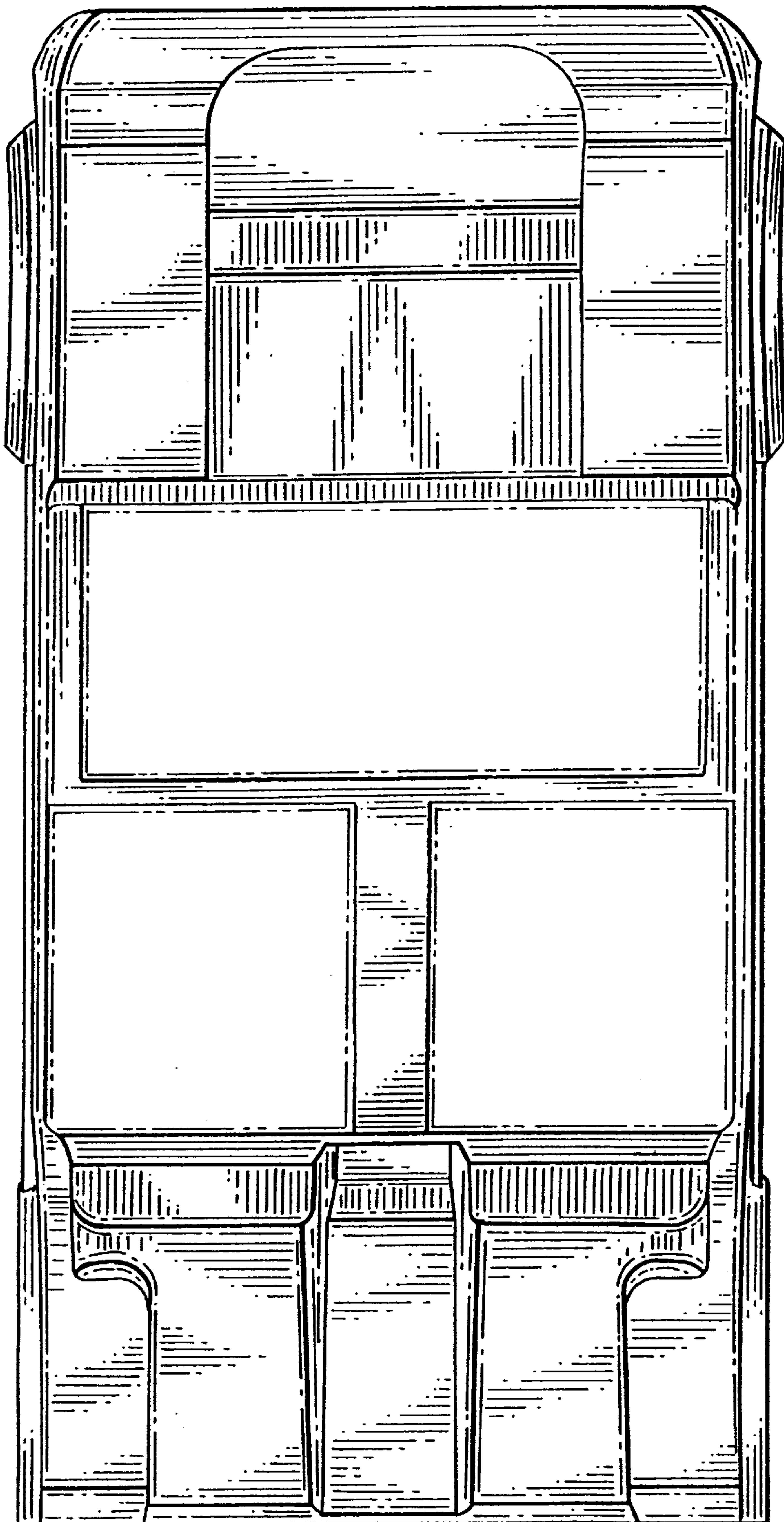

Fig. 10

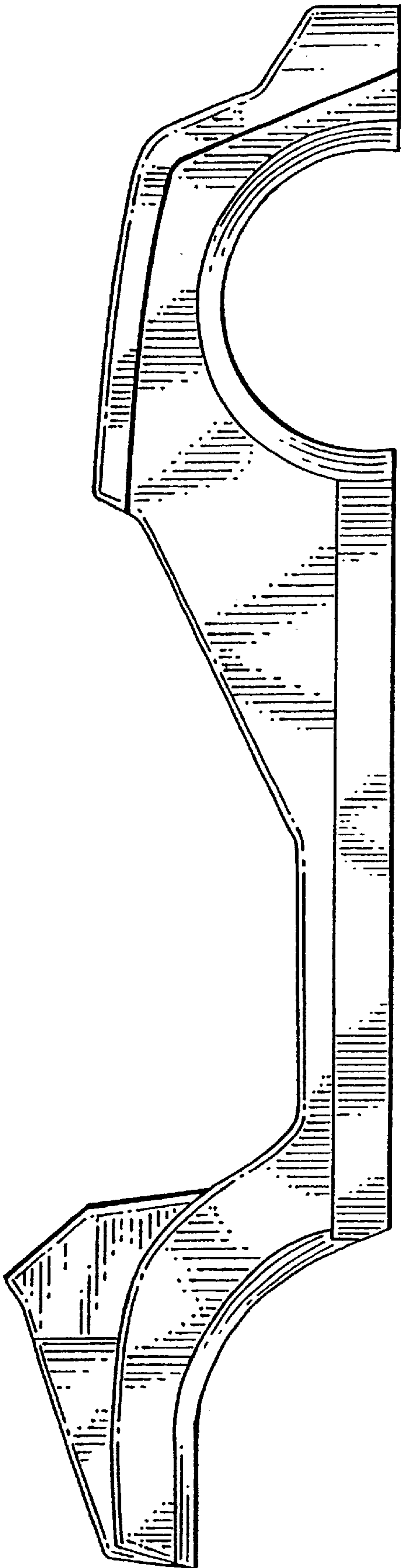

Fig. 11

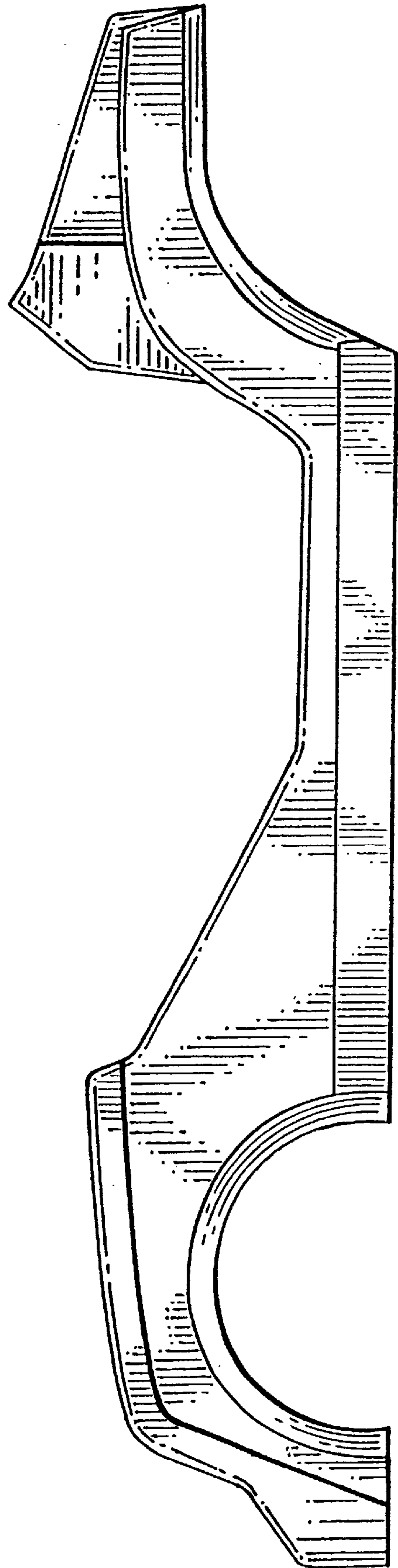

Fig. 12

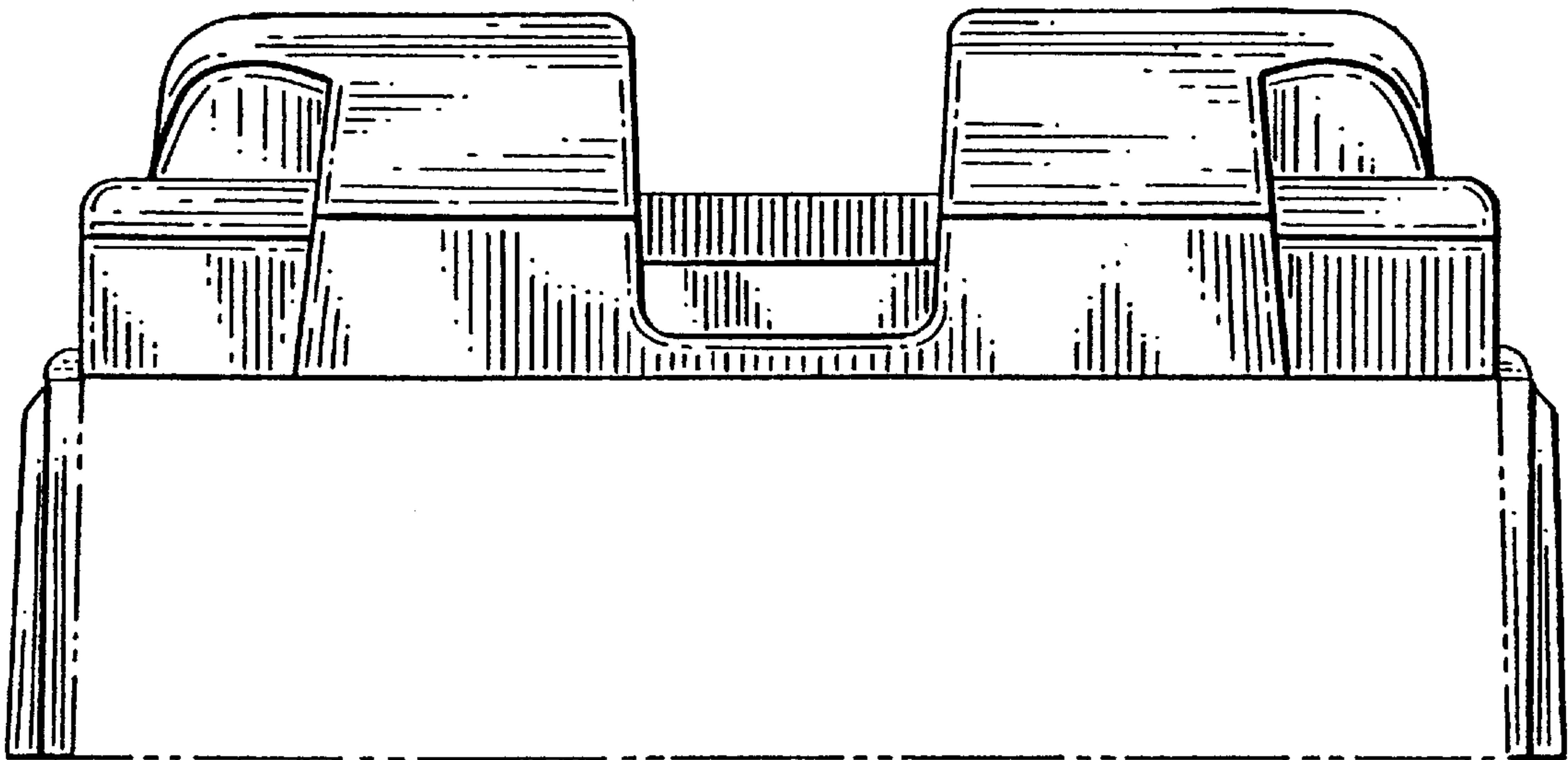

Fig. 13

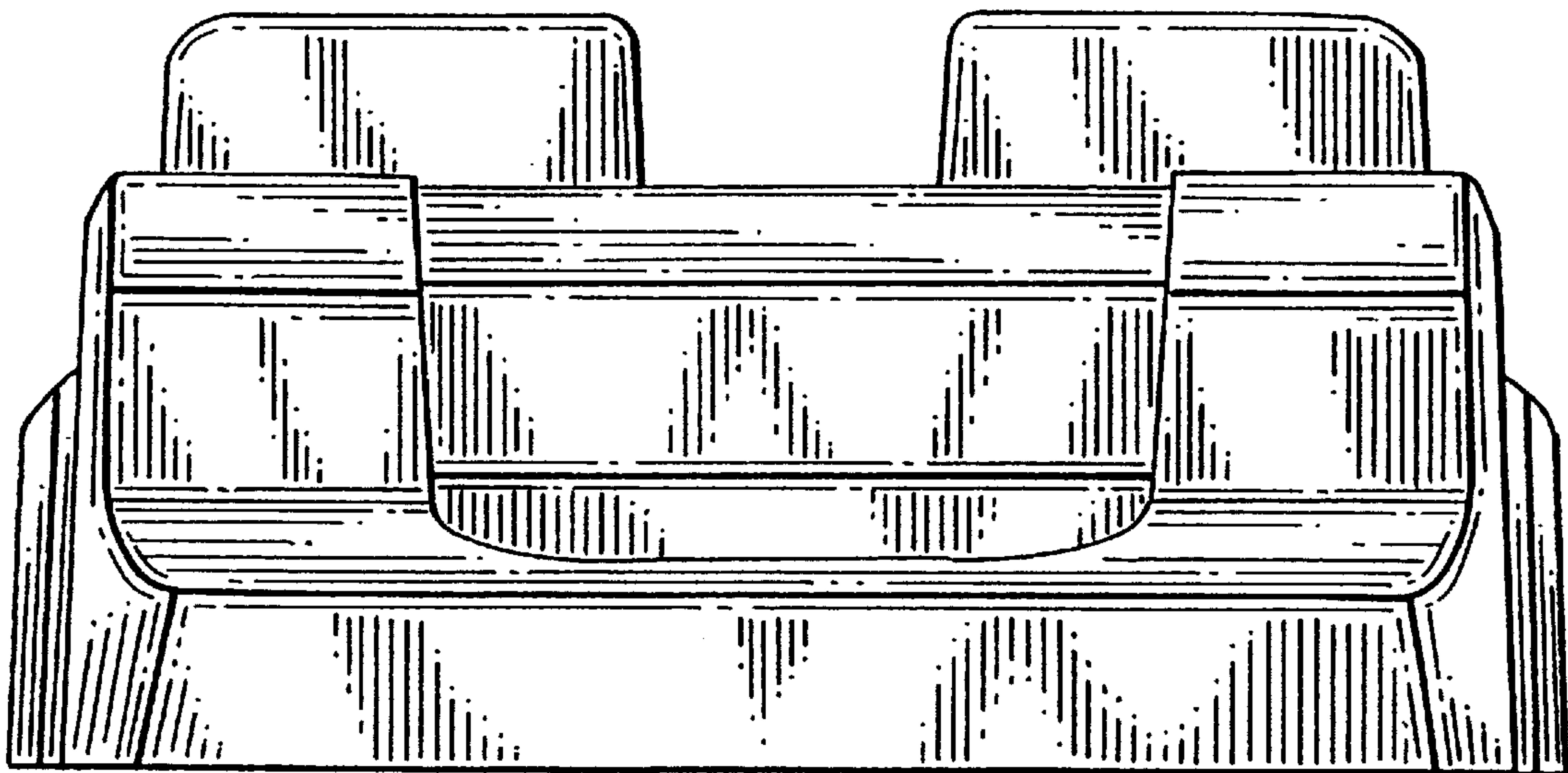

Fig. 14