



US00D462027S

(12) **United States Design Patent**  
**Ubiera**

(10) **Patent No.:** **US D462,027 S**

(45) **Date of Patent:** **\*\* Aug. 27, 2002**

(54) **ILLUMINATED VEHICLE DISPLAY UNIT**

*Primary Examiner*—Antoine Duval Davis

(76) Inventor: **Bartolome Ubiera**, 12941 NW. 2nd Ave., Miami, FL (US) 33168

(57) **CLAIM**

The ornamental design for a illuminated vehicle display unit, as shown and described.

(\*\*) Term: **14 Years**

**DESCRIPTION**

(21) Appl. No.: **29/150,443**

FIG. 1 is a front elevational view of the illuminated vehicle display unit of the present invention;

(22) Filed: **Nov. 16, 2001**

FIG. 2 is a rear elevational view of the illuminated vehicle display unit of FIG. 1;

(51) **LOC (7) Cl.** ..... **10-05**

(52) **U.S. Cl.** ..... **D10/114**

(58) **Field of Search** ..... D10/114; 116/28 R, 116/42; 340/468, 463, 461, 473, 475, 471, 464, 479, 480, 482, 485; 362/80.1, 80.2

FIG. 3 is a left side elevational view of the illuminated vehicle display unit of FIG. 1;

FIG. 4 is a right side elevational view of the illuminated vehicle display unit of FIG. 1;

(56) **References Cited**

**U.S. PATENT DOCUMENTS**

4,574,269	A	3/1986	Miller	
D310,047	S	* 8/1990	Vance, Sr.	..... D10/114
4,949,071	A	8/1990	Hutchison	
D374,191	S	10/1996	Terrebonne et al.	
5,578,986	A	11/1996	Isobe et al.	
5,905,434	A	5/1999	Steffan et al.	
6,154,126	A	11/2000	Beasley et al.	

FIG. 5 is a top plan view of the illuminated vehicle display unit of FIG. 1;

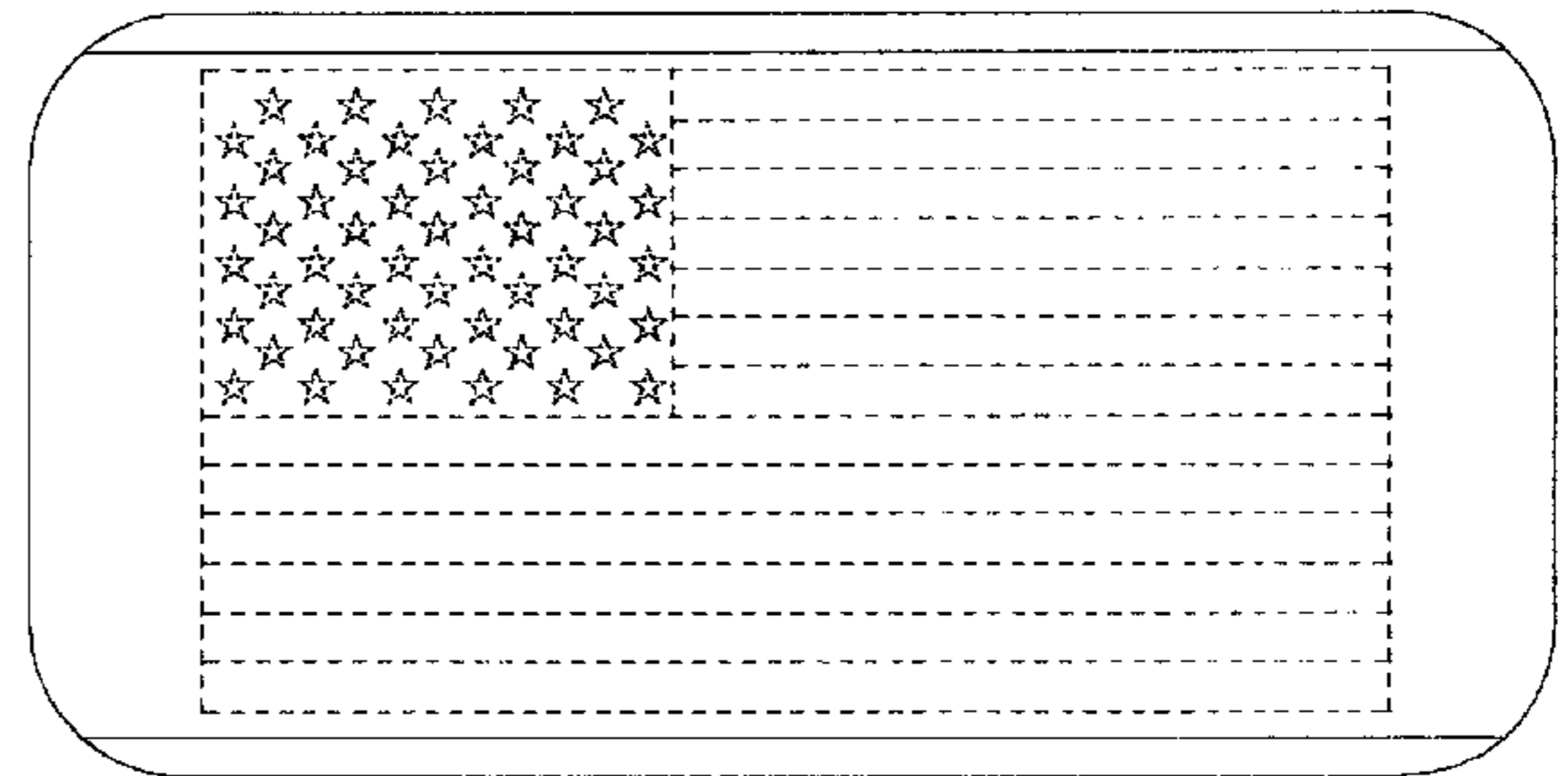
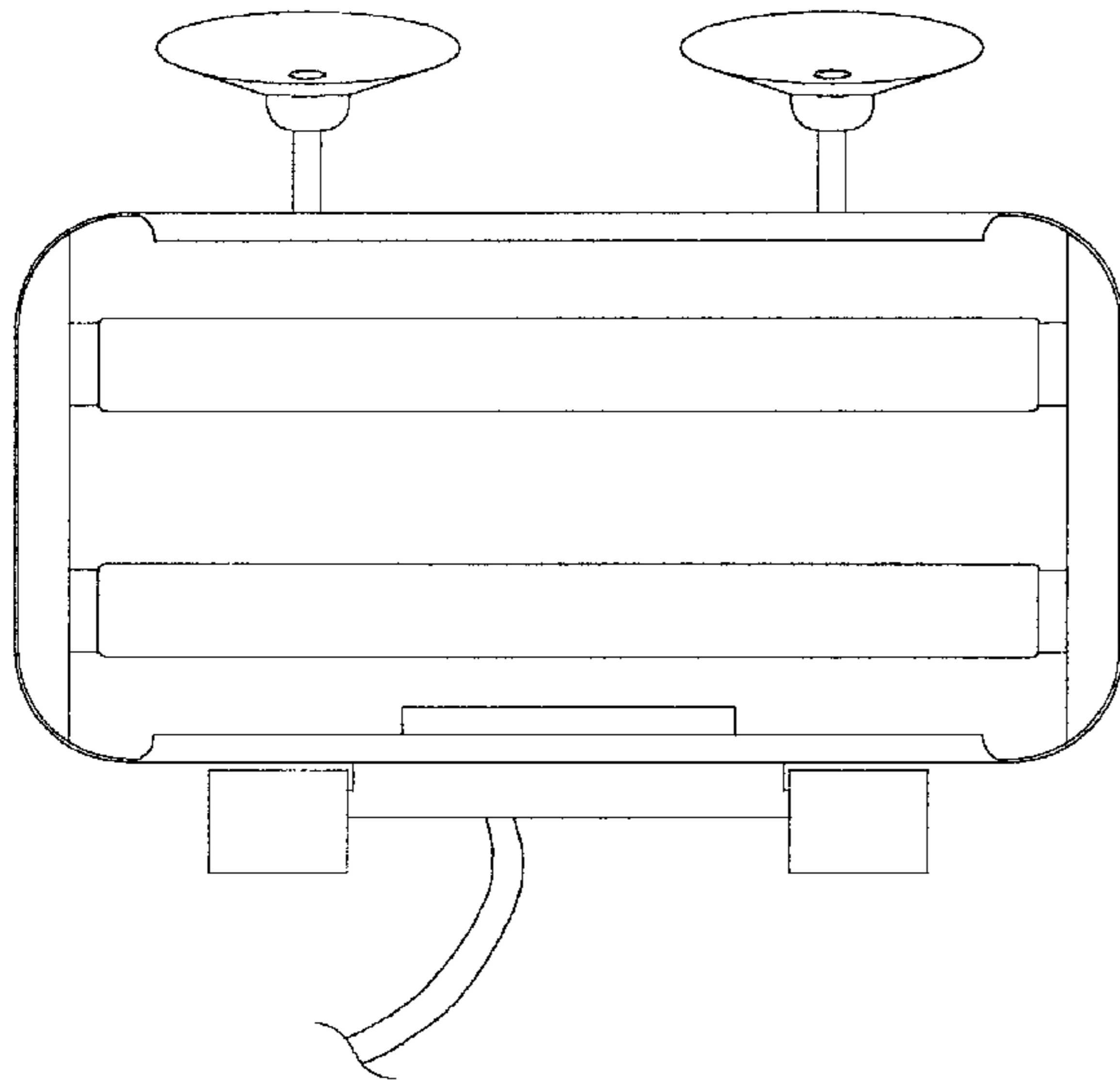
FIG. 6 is a bottom plan view of the illuminated vehicle display unit of FIG. 1; and,

FIG. 7 is a top, front, left side perspective in an alternate position (slide on display unit).

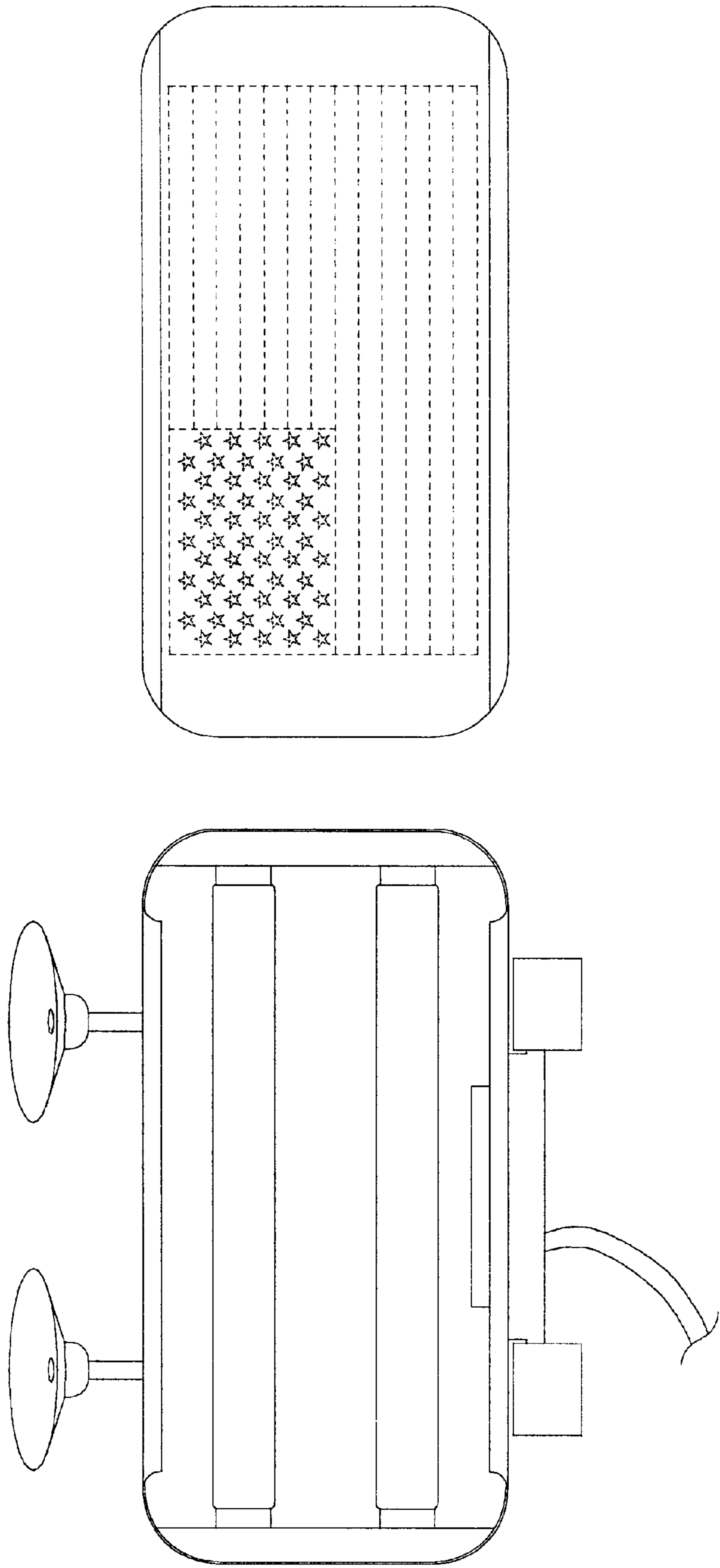
The broken lines showing of an American flag in FIGS. 1, 2, and 7 are for illustrative purposes only and form no part of the claimed design.

\* cited by examiner

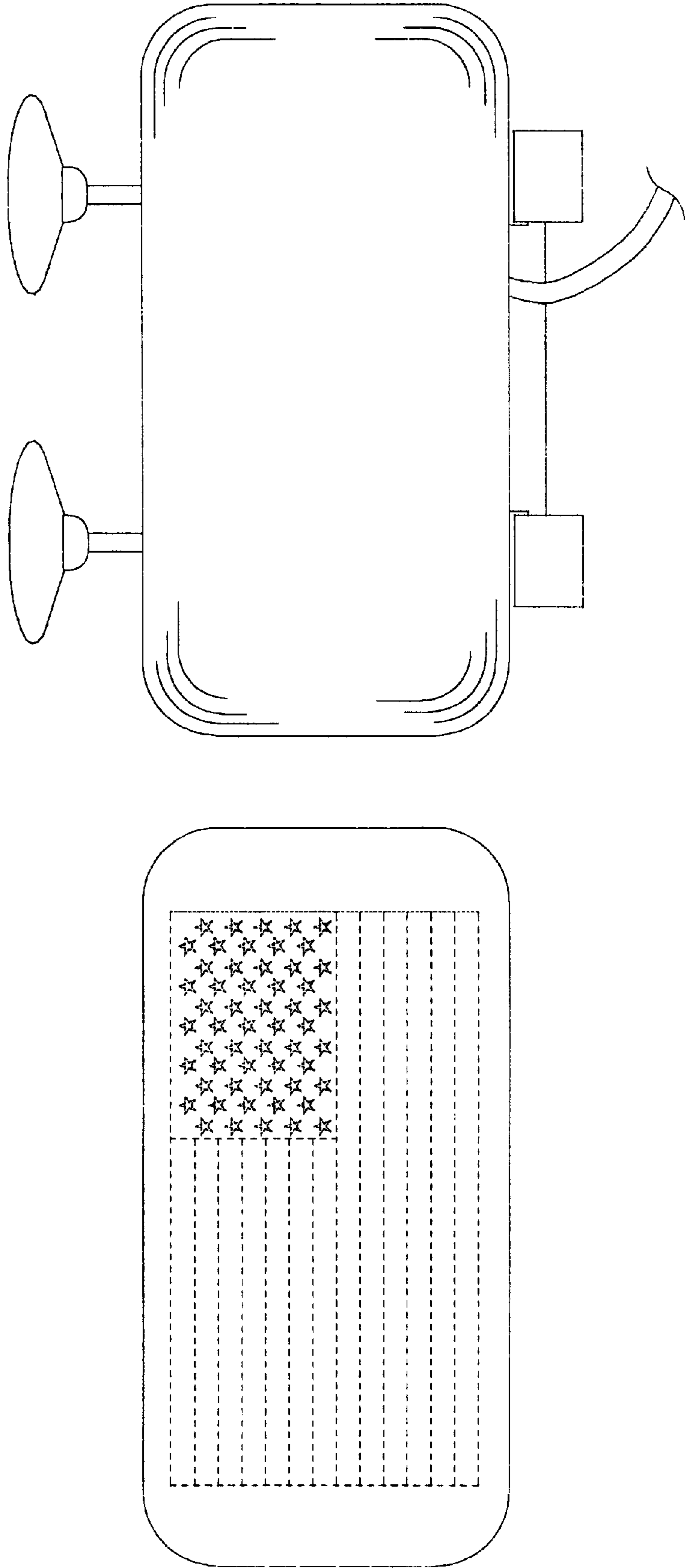
**1 Claim, 6 Drawing Sheets**



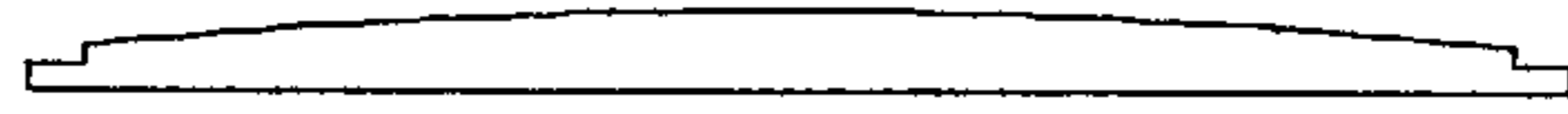
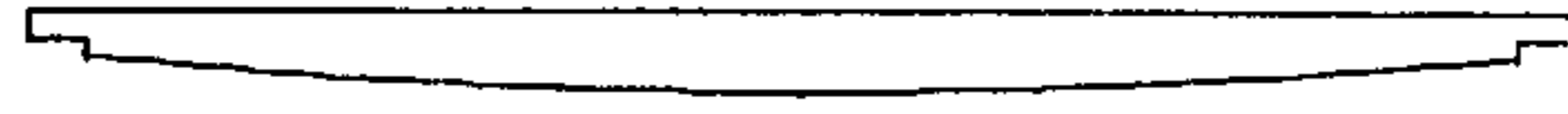
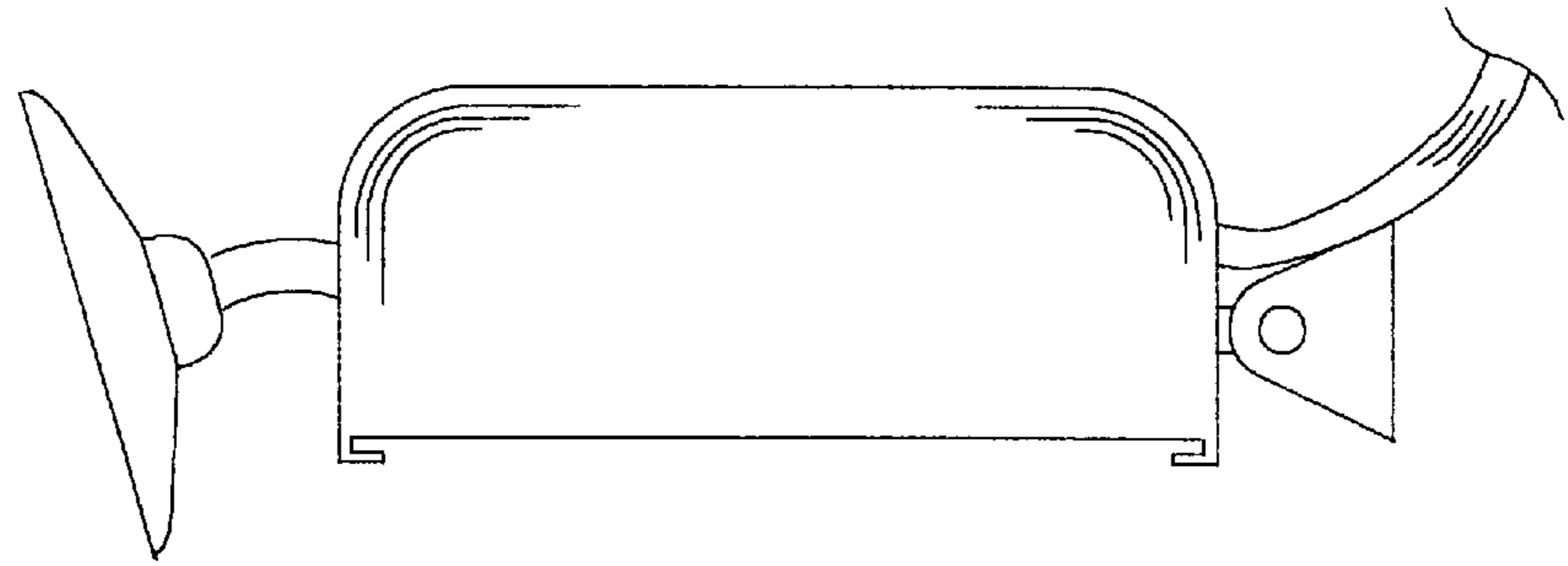
**FIG. 1**



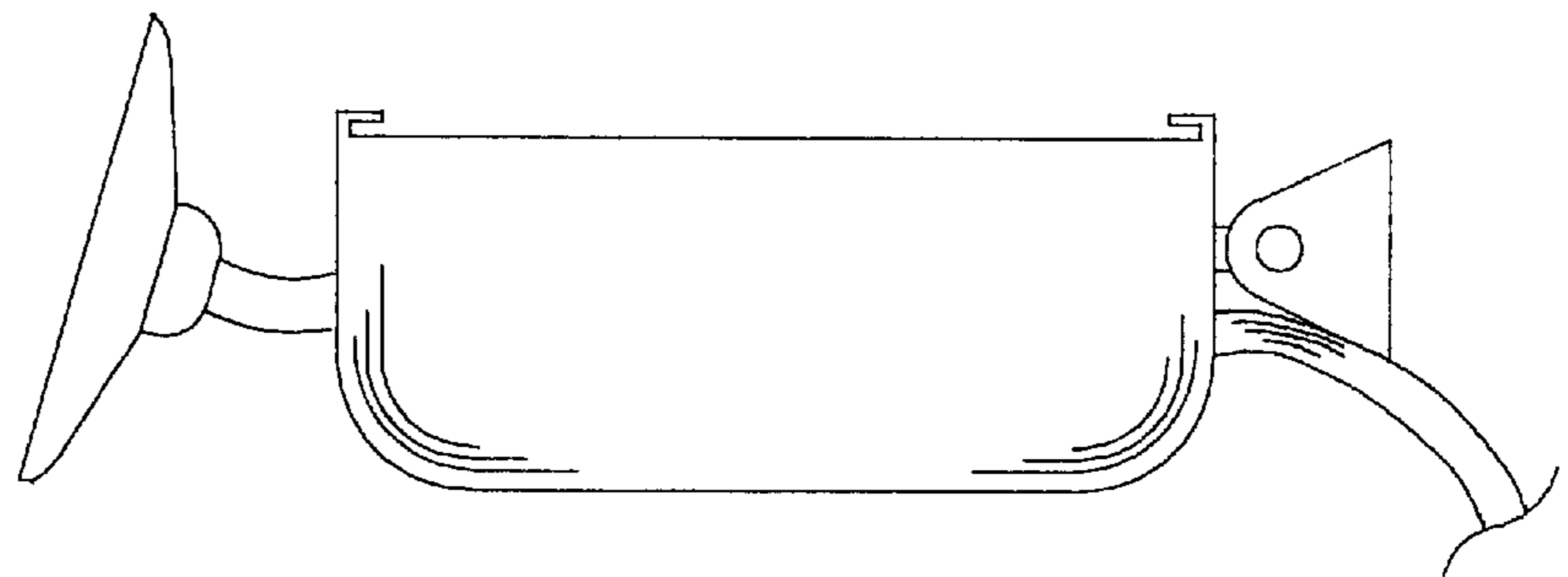
**FIG. 2**



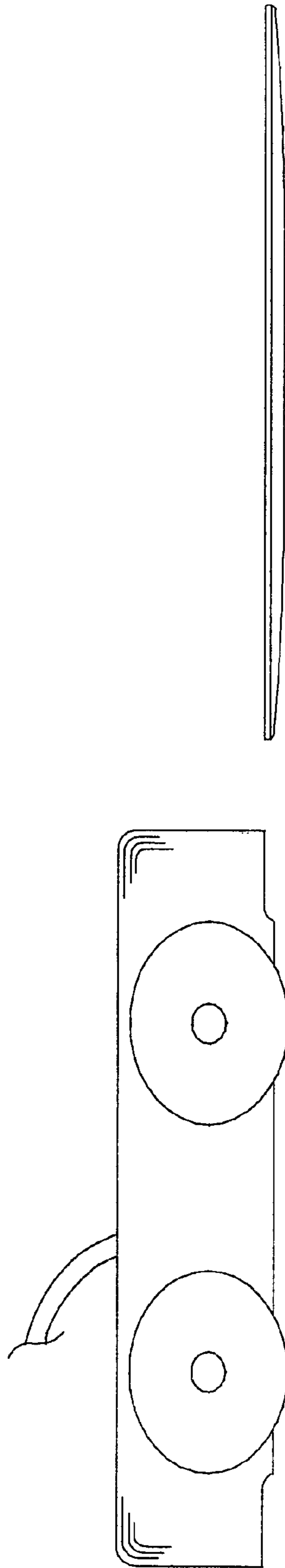
**FIG. 4**



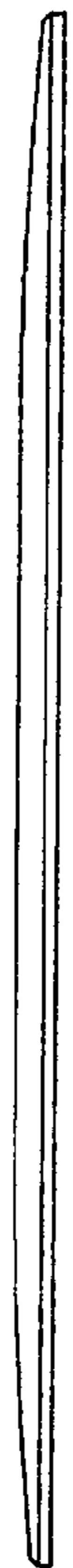
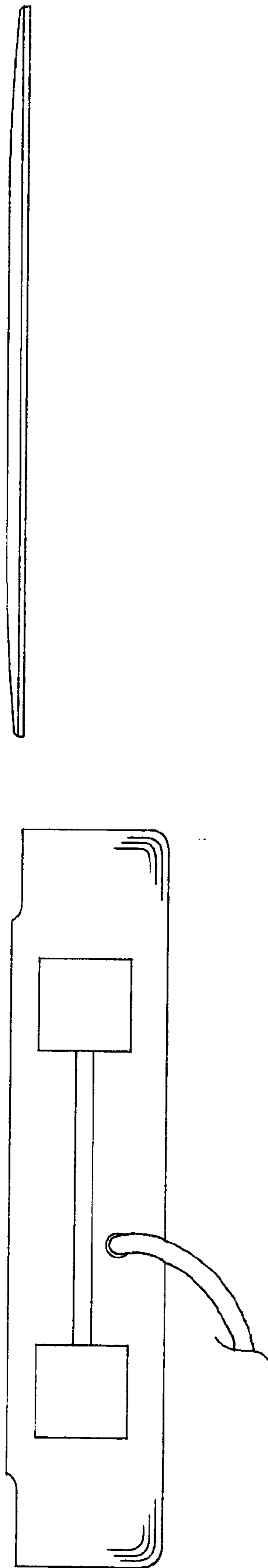
**FIG. 3**

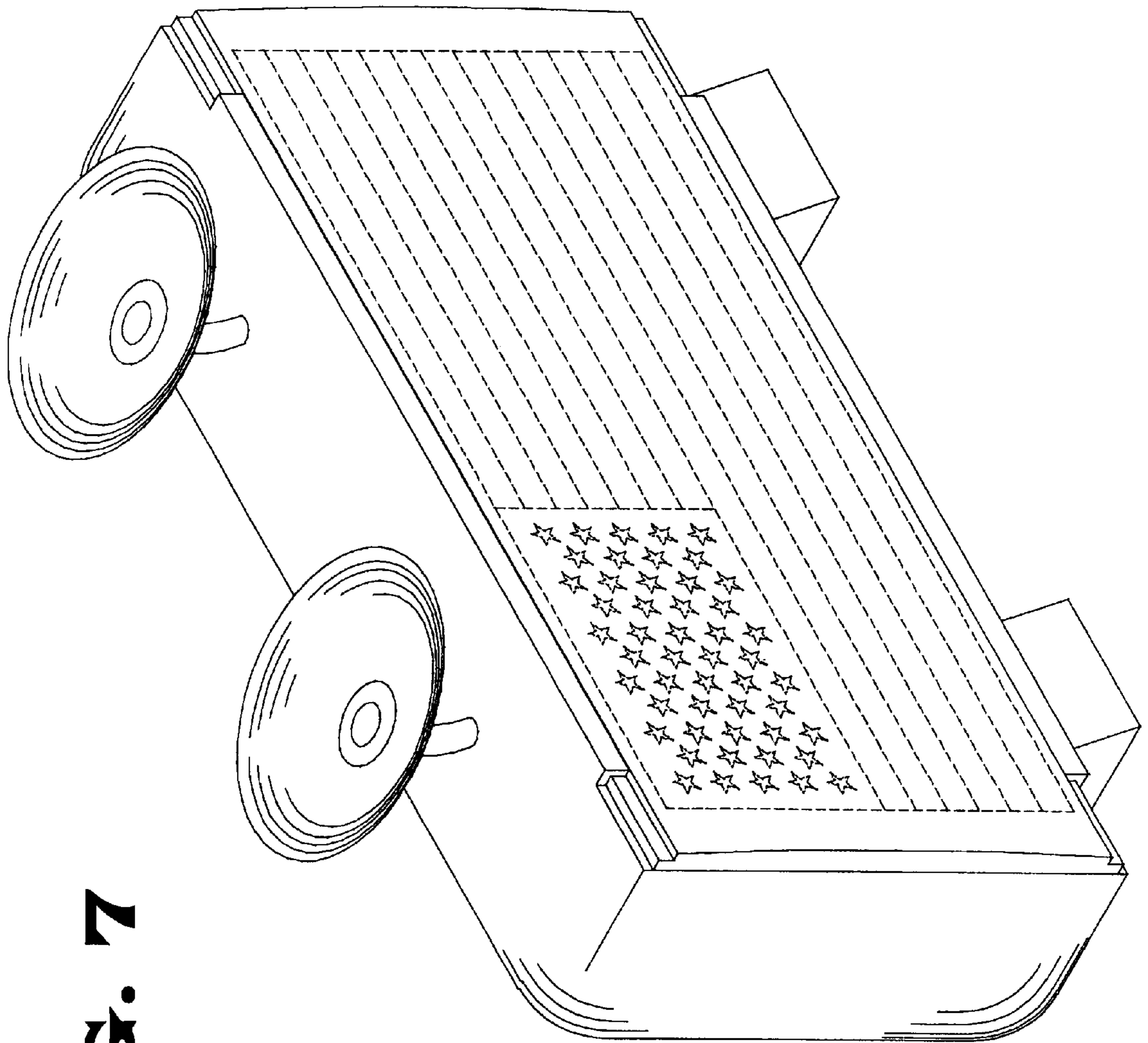


**FIG. 5**



**FIG. 6**





**FIG. 7**