



US00D462005S

(12) **United States Design Patent**
Nakamaru

(10) **Patent No.:** **US D462,005 S**

(45) **Date of Patent:** **** Aug. 27, 2002**

(54) **HOUSING PORTION OF FINGERPRINT IDENTIFICATION LOCK**

5,550,529 A * 8/1996 Burge 70/455 X
6,111,977 A * 8/2000 Scott et al. 340/825.31 X
6,141,436 A * 10/2000 Srey et al. 340/825.34 X

(75) Inventor: **Takao Nakamaru, Tokyo (JP)**

* cited by examiner

(73) Assignee: **Alpha Corporation (JP)**

Primary Examiner—Brian N. Vinson

(**) Term: **14 Years**

(74) *Attorney, Agent, or Firm*—SAIDMAN DesignLaw Group

(21) Appl. No.: **29/142,690**

(57) **CLAIM**

(22) Filed: **May 31, 2001**

The ornamental design for a housing portion of fingerprint identification lock, as shown and described.

(51) **LOC (7) Cl.** **08-08**

DESCRIPTION

(52) **U.S. Cl.** **D8/343**

(58) **Field of Search** D8/330, 331, 343,
D8/346; 70/57, 91, 78, 51, 52, 54, 55, 56,
455, DIG. 43; 235/380, 382; 340/825.31,
825.34

FIG. 1 is a front view of a housing portion of fingerprint identification lock showing my new design;
FIG. 2 is a right side view thereof;
FIG. 3 is a top view thereof;
FIG. 4 is a bottom view thereof;
FIG. 5 is a rear view thereof; and,
FIG. 6 is a left side view thereof.

(56) **References Cited**

U.S. PATENT DOCUMENTS

D293,415 S * 12/1987 Whitley, II D8/346
D322,386 S * 12/1991 Ginther et al. D8/330
D333,972 S * 3/1993 Hyatt, Jr. et al. D8/346 X
5,473,144 A * 12/1995 Mathurin, Jr. 235/380

The broken lines shown in FIGS. 1–6 represent environmental subject matter and form no part of the claimed design.

1 Claim, 2 Drawing Sheets

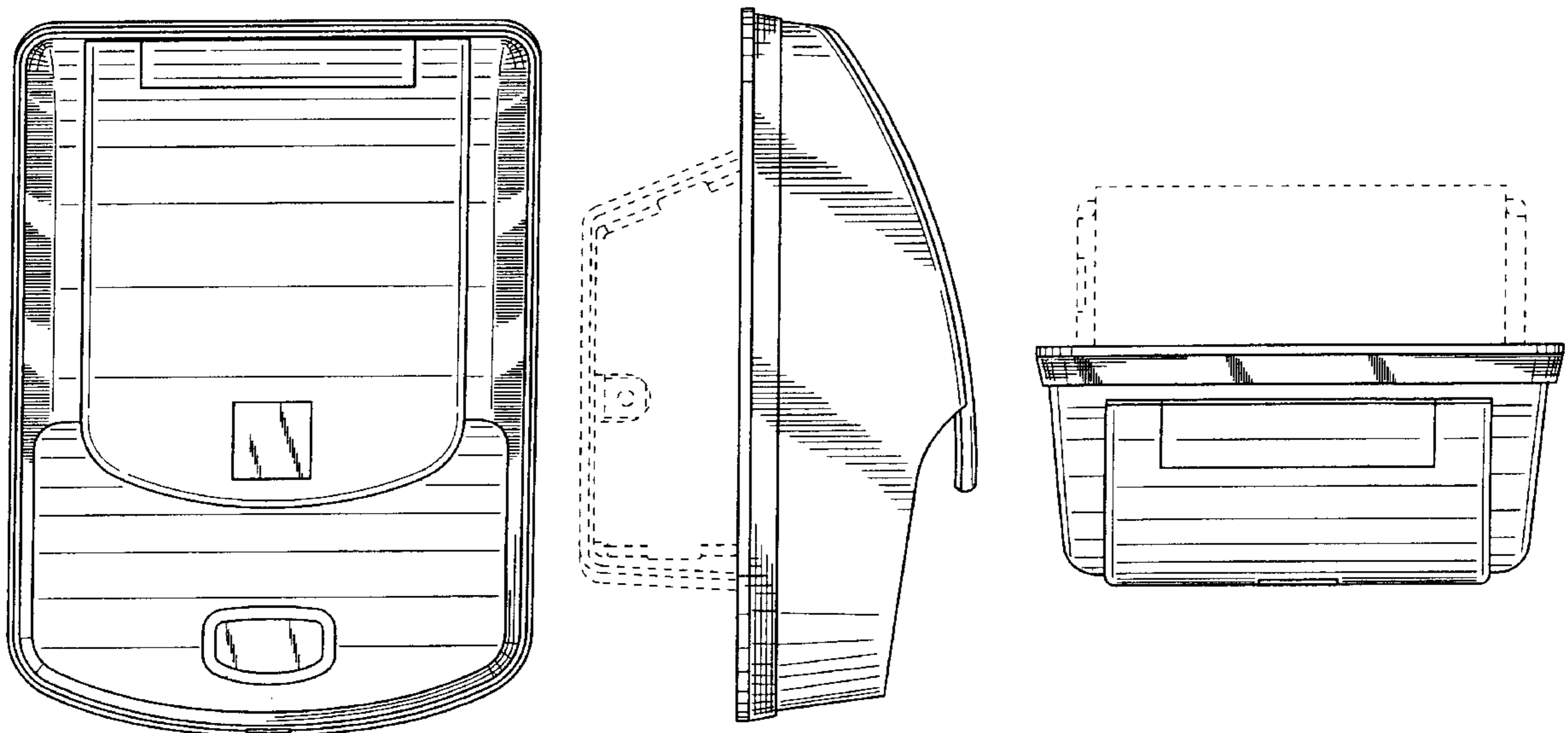

FIG.3

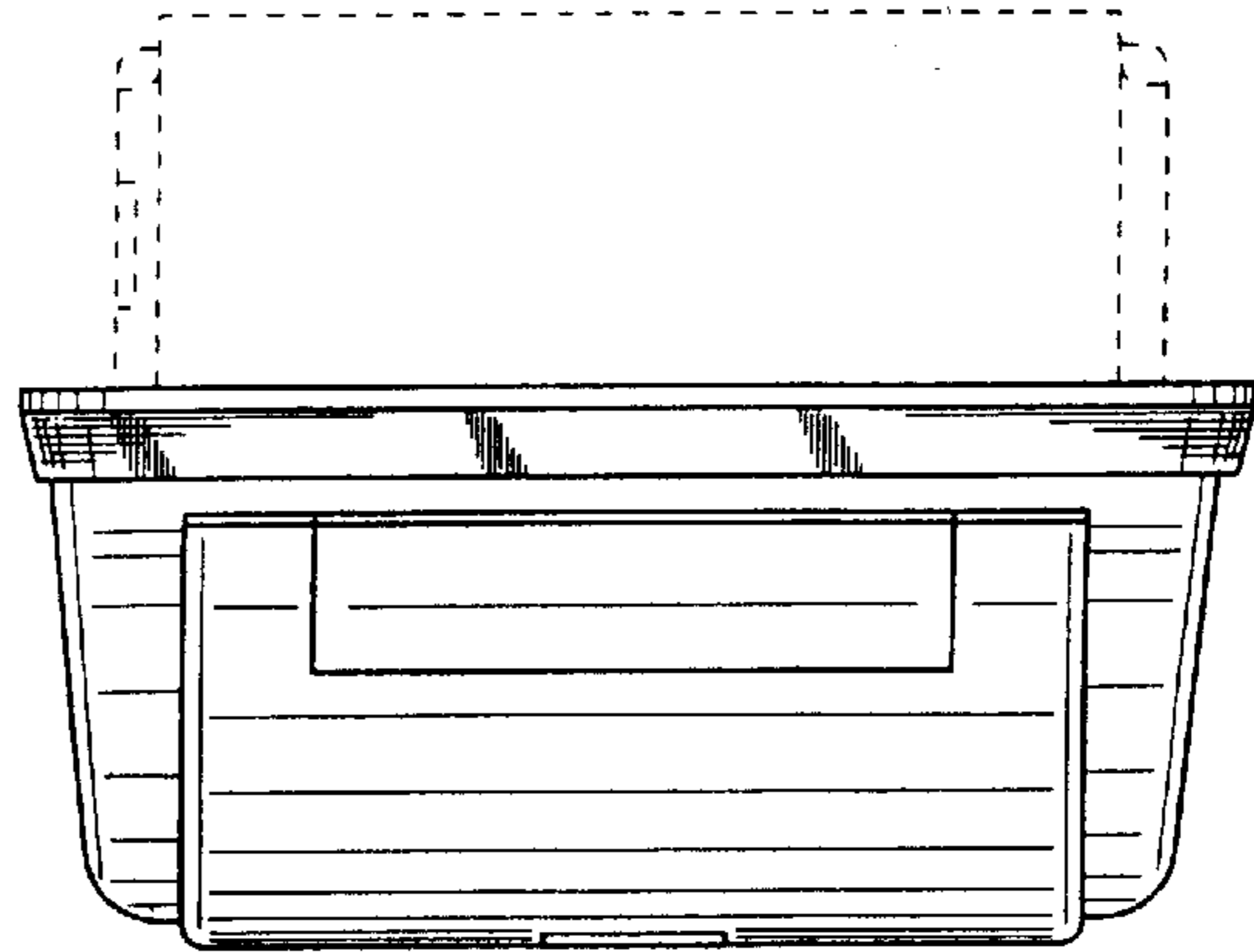

FIG.2

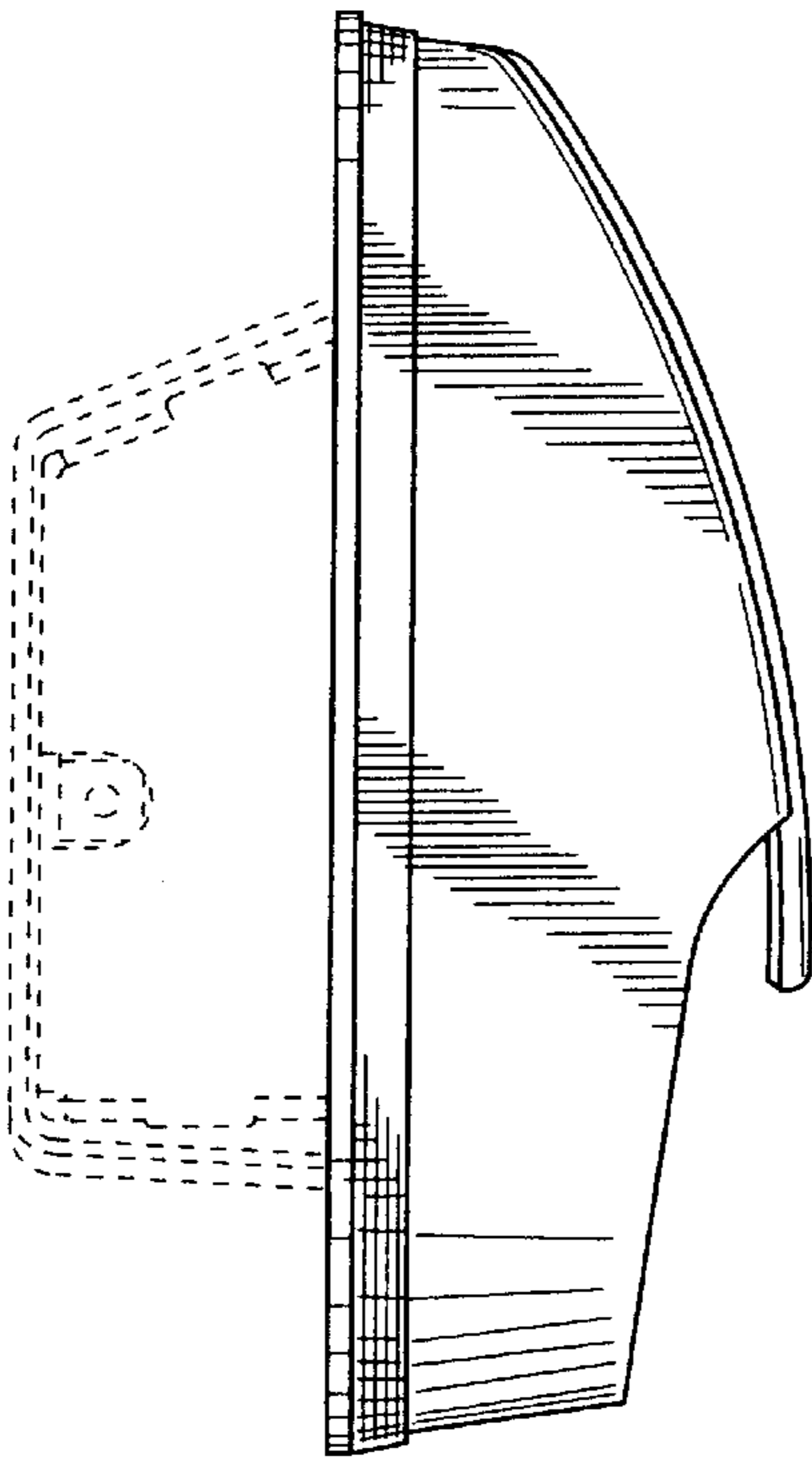

FIG.1

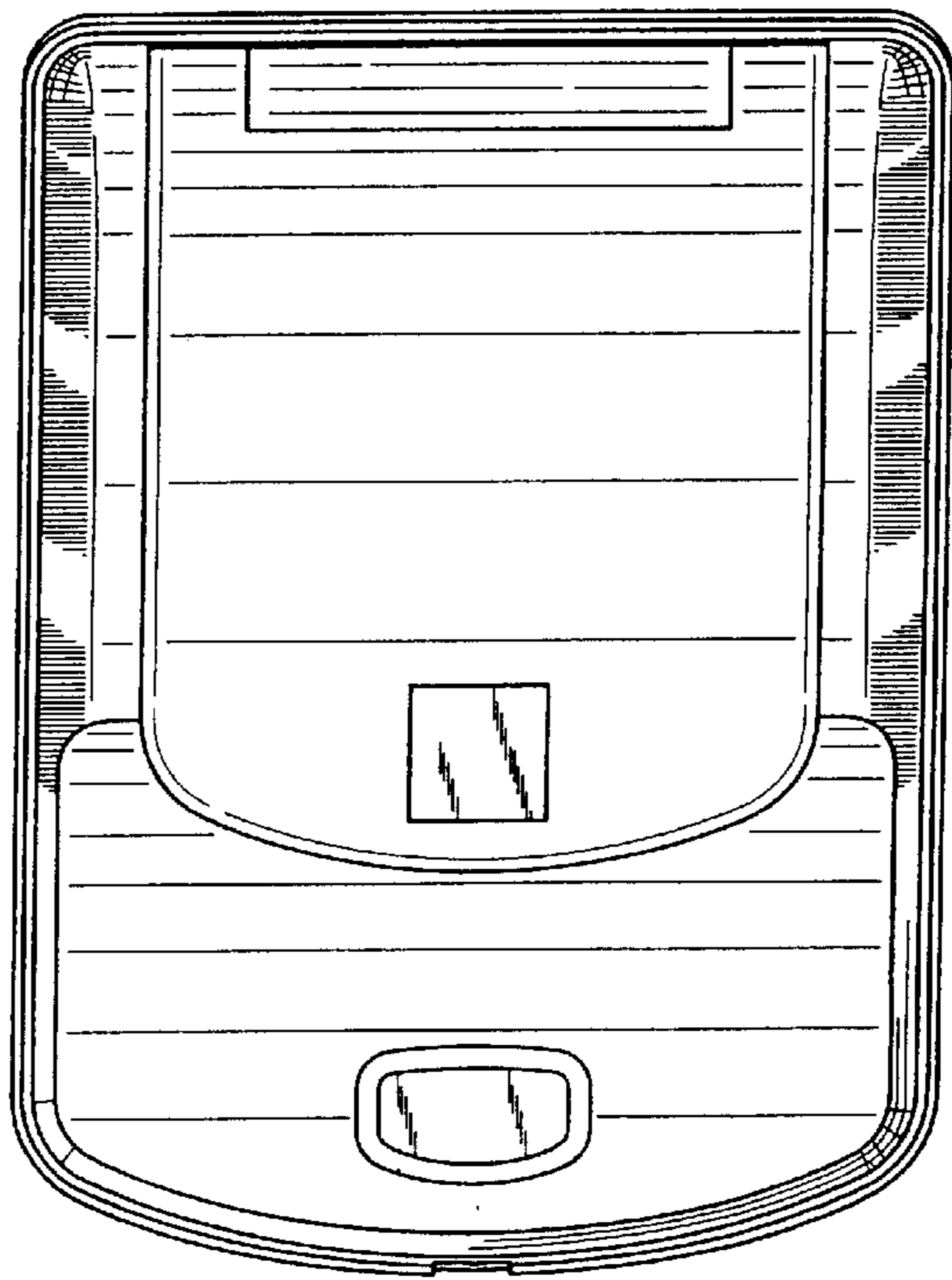

FIG.4

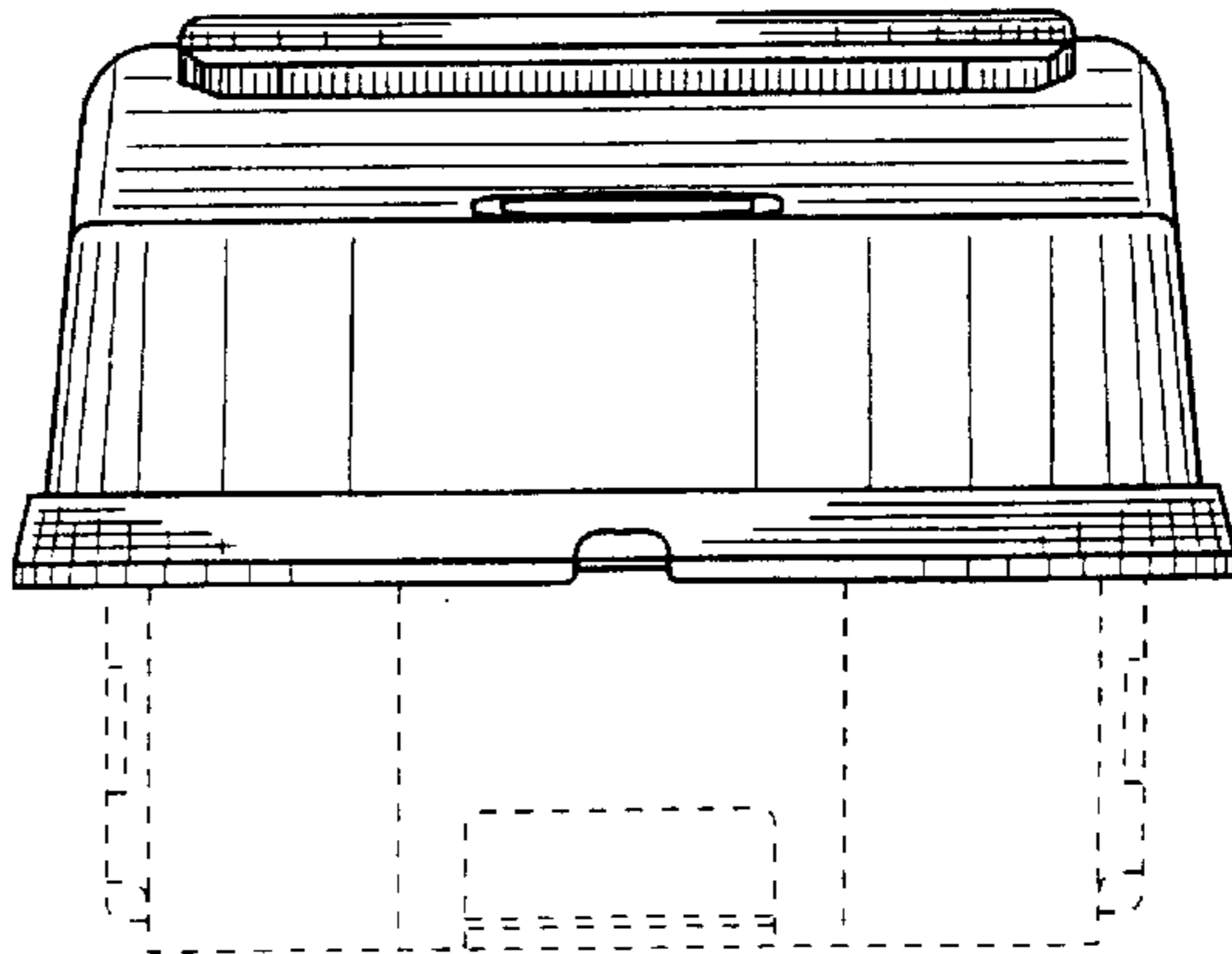

FIG.6

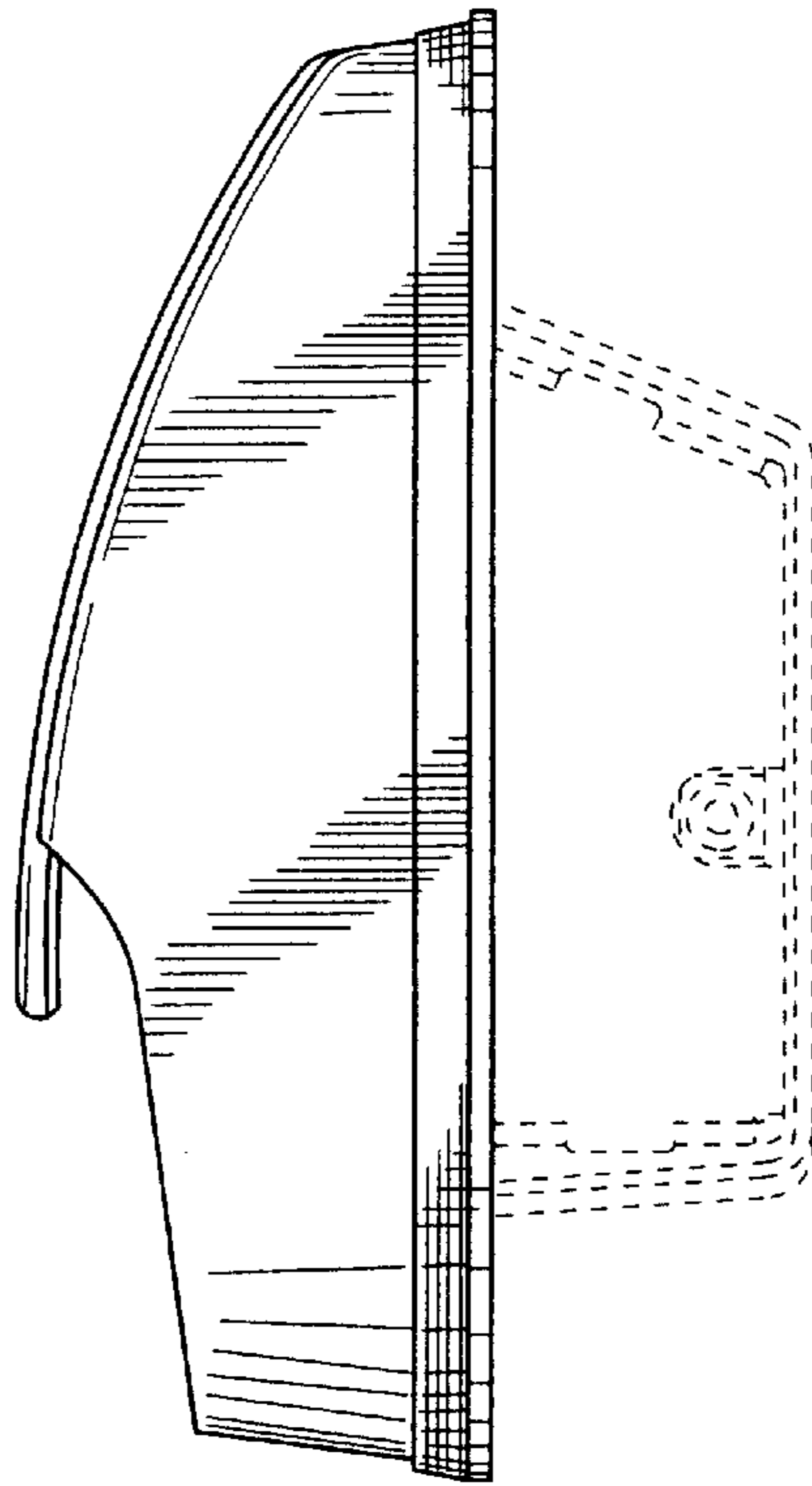

FIG.5

