



US00D461760S

(12) **United States Design Patent** (10) **Patent No.:** **US D461,760 S**
Booth (45) **Date of Patent:** **** Aug. 20, 2002**

(54) **MOTORCYCLE AUDIO APPARATUS HOUSING**

(76) Inventor: **Robert George Booth**, P.O. Box 441, Jamison Centre Act (AU), 2614

(**) Term: **14 Years**

(21) Appl. No.: **29/141,621**

(22) Filed: **May 9, 2001**

(51) **LOC (7) Cl.** **12-16**

(52) **U.S. Cl.** **D12/409**

(58) **Field of Search** D12/110, 114, D12/407, 409, 410, 415, 422, 192; 180/219, 90; D3/218, 231, 303; 455/345; 224/924, 412, 413, 419-426, 428-439; 296/37.5, 37.6; 280/288.4; 150/167; 312/7.1; D14/157

(56) **References Cited**

U.S. PATENT DOCUMENTS

D242,997 S	1/1977	Dixson	
D245,003 S	7/1977	Fritts et al.	
D251,120 S	2/1979	Hoese	
D256,115 S	7/1980	Dixson	
D257,142 S	9/1980	Dixson	
D257,967 S	1/1981	Hoese	
D257,971 S	1/1981	Hoese	
D263,577 S	3/1982	Hoese	
D266,409 S	10/1982	Hoese	
D266,410 S	10/1982	Hoese	
D275,382 S	9/1984	Hoese	
D276,903 S	12/1984	Hoese	
D278,328 S	4/1985	Hoese	
D281,871 S	12/1985	Heiman	
5,159,712 A	* 10/1992	Schneider et al.	224/420 X
D374,855 S	* 10/1996	Lazzeroni et al.	D12/415

* cited by examiner

Primary Examiner—Alan P. Douglas

Assistant Examiner—Linda Brooks

(74) *Attorney, Agent, or Firm*—Pitney, Hardin, Kipp & Szuch LLP

(57) **CLAIM**

The ornamental design for a motorcycle audio apparatus housing, substantially as shown and described

DESCRIPTION

FIG. 1 is a front elevational view of a motorcycle audio apparatus housing showing my new design;

FIG. 2 is a top plan view of the motorcycle audio apparatus housing;

FIG. 3 is a bottom plan view of the motorcycle audio apparatus housing;

FIG. 4 is a rear elevational view of the motorcycle audio apparatus housing;

FIG. 5 is a right end elevational view of the motorcycle audio apparatus housing;

FIG. 6 is a front perspective view of the motorcycle audio apparatus housing;

FIG. 7 is a view similar to that of FIG. 6 with the closure flap of the motorcycle audio apparatus housing shown in an open position revealing a recess for audio apparatus and mounting apertures of components;

FIG. 8 is a rear perspective view of the motorcycle audio apparatus housing;

FIG. 9 is a front perspective view of the motorcycle audio apparatus housing from below;

FIG. 10 is a perspective view (similar to that of FIG. 7 but on a smaller scale) of the motorcycle audio apparatus housing mounted on the windscreen of a motorcycle, the motorcycle and the windscreen are only shown for illustrative purposes and form no part of the design; and,

FIG. 11 is a perspective view (similar to that of FIG. 6 but on a smaller scale) of the motorcycle audio apparatus housing mounted on the windscreen of a motorcycle, the motorcycle and windscreen are only show for illustrative purposes and form no part of the design.

The broken lines shown on the motorcycle audio apparatus housing represent stitching.

1 Claim, 4 Drawing Sheets

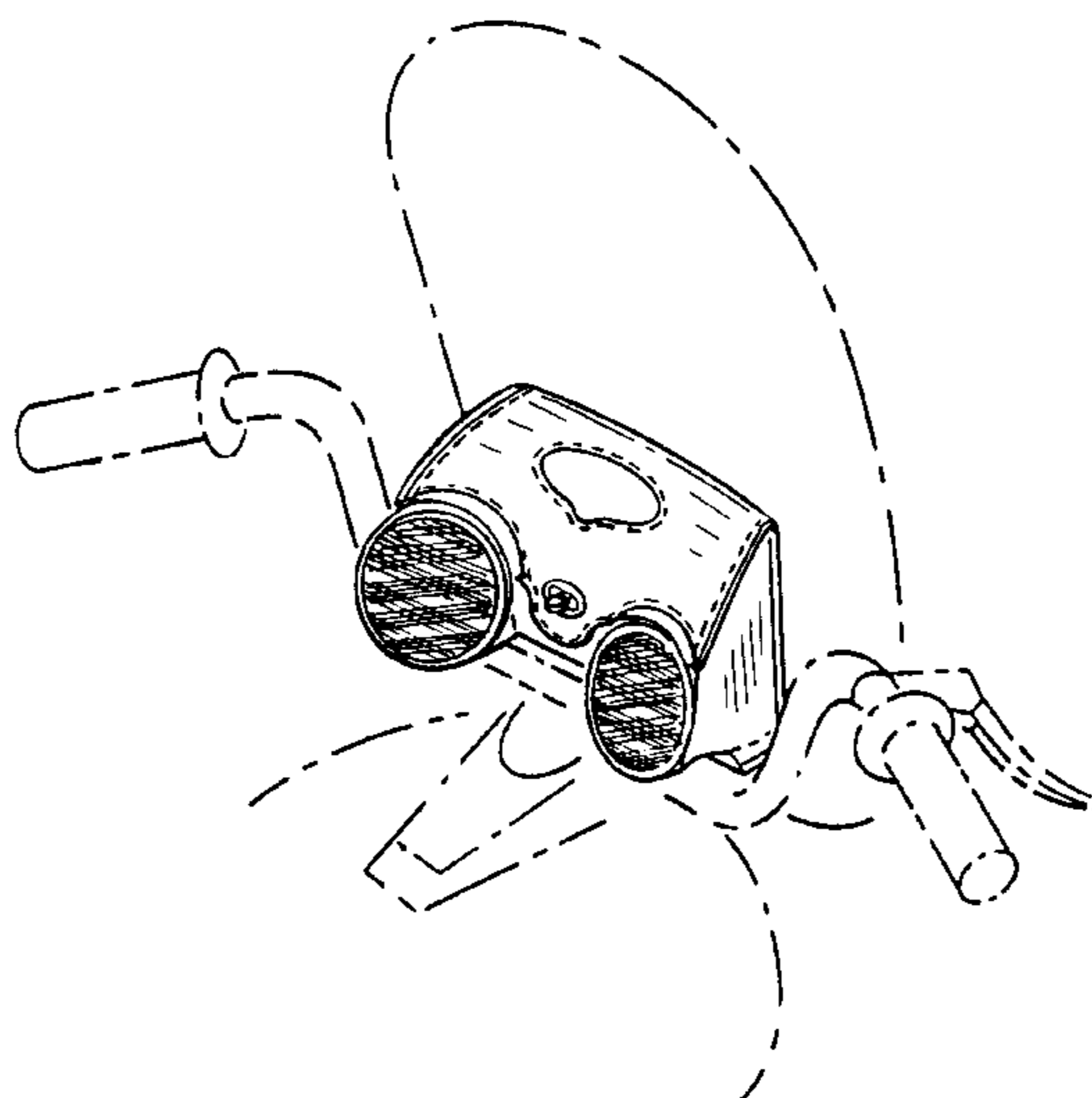

FIG. 2

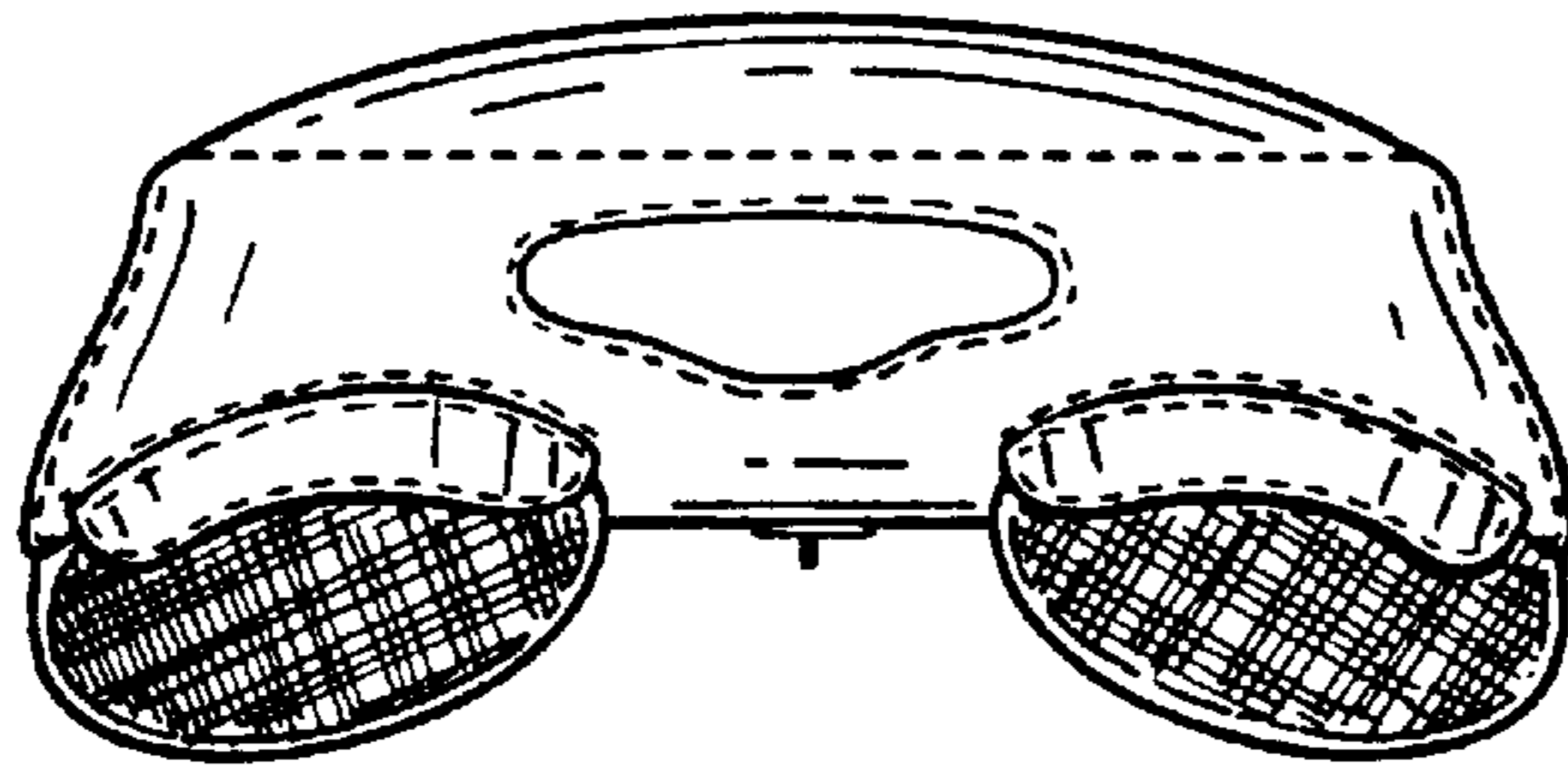

FIG. 1

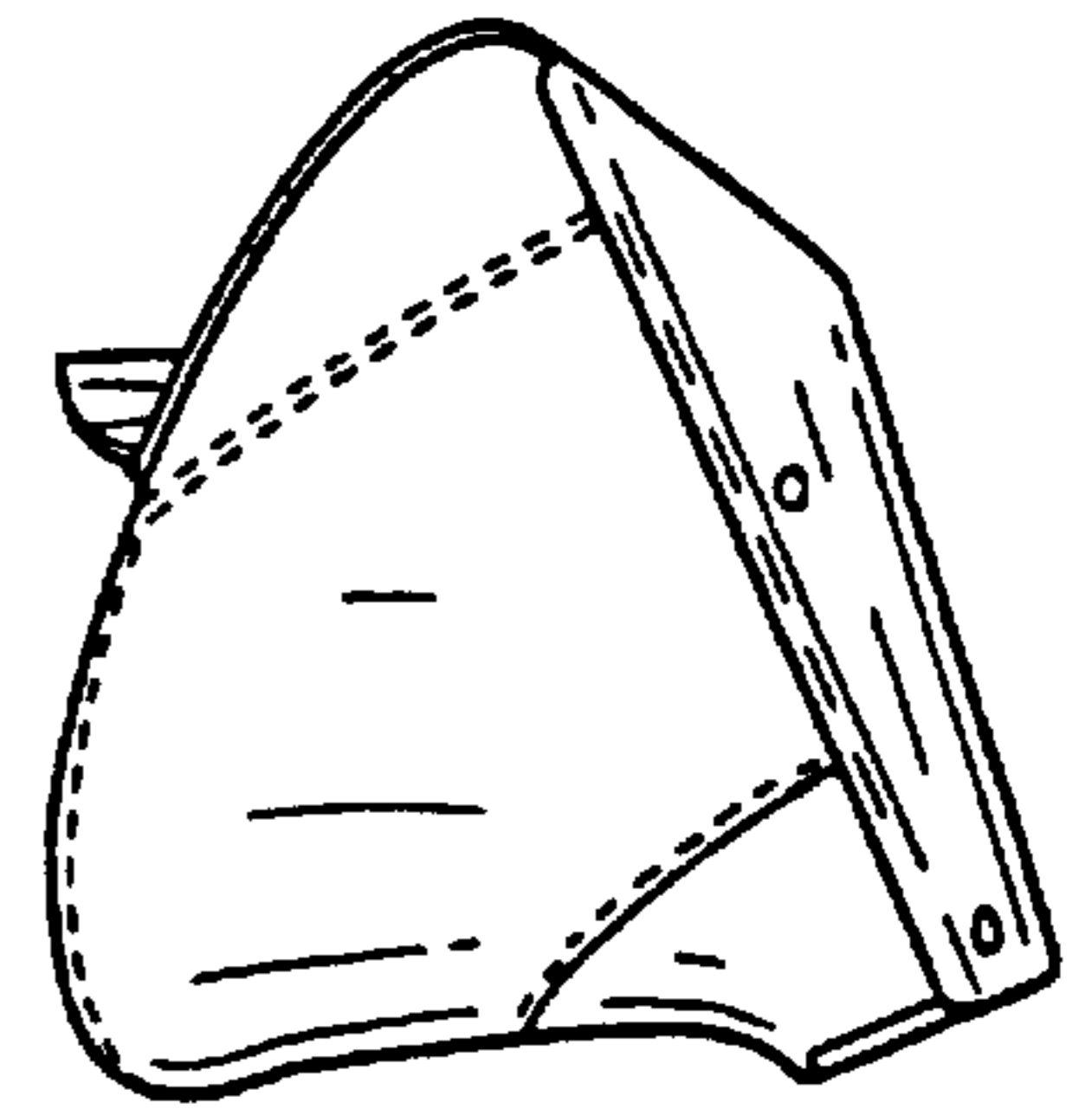
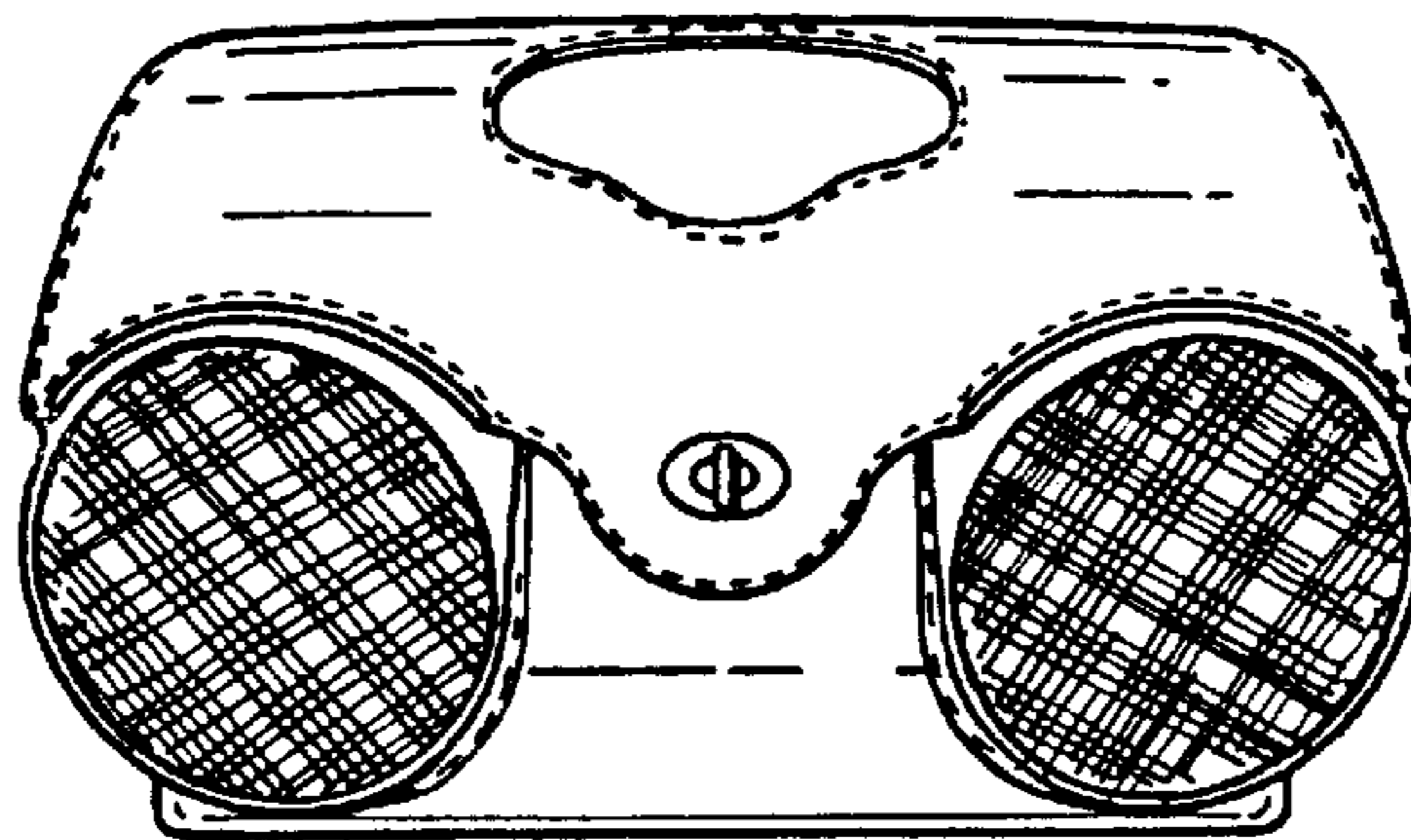

FIG. 5

FIG. 3

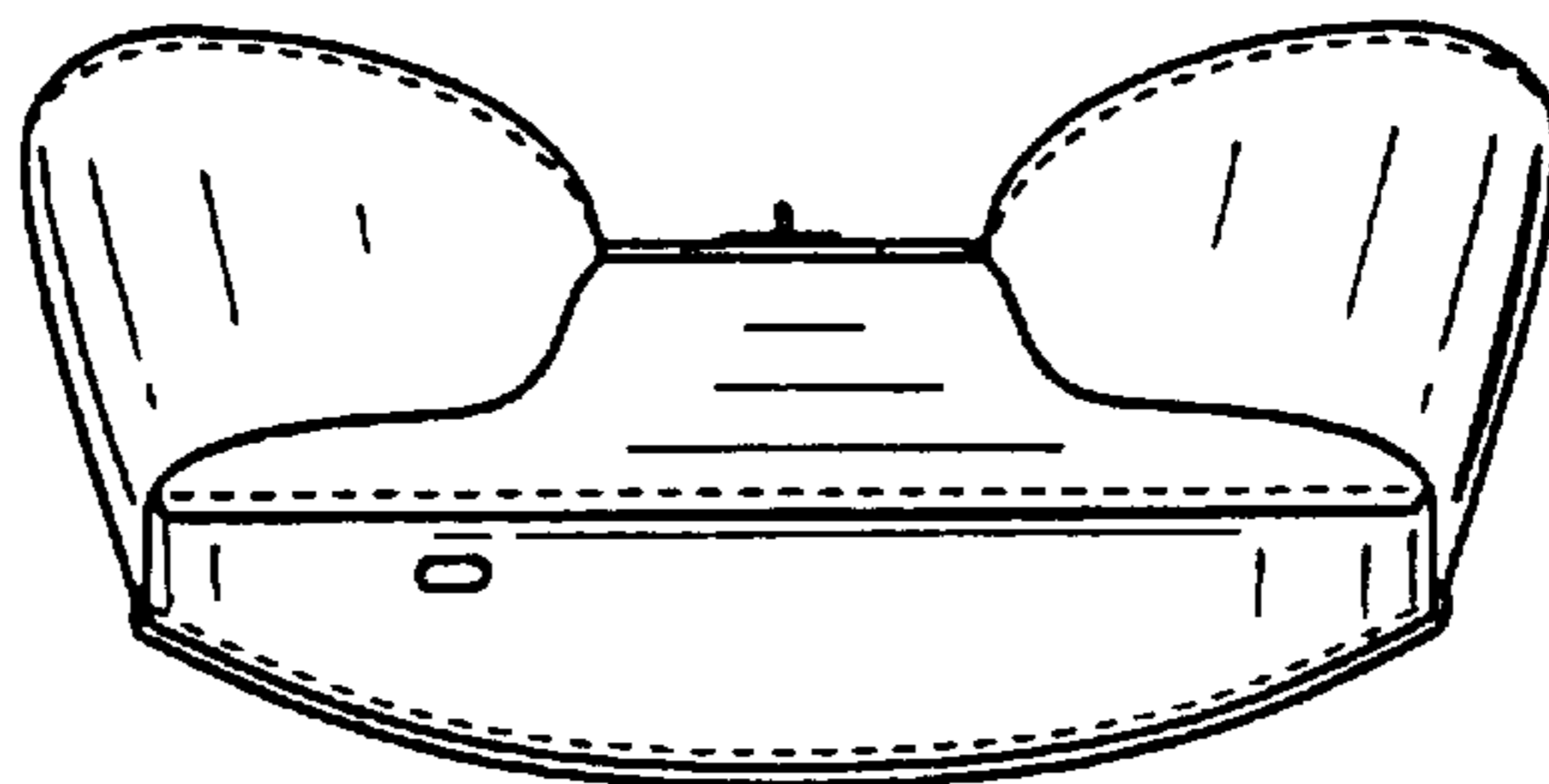
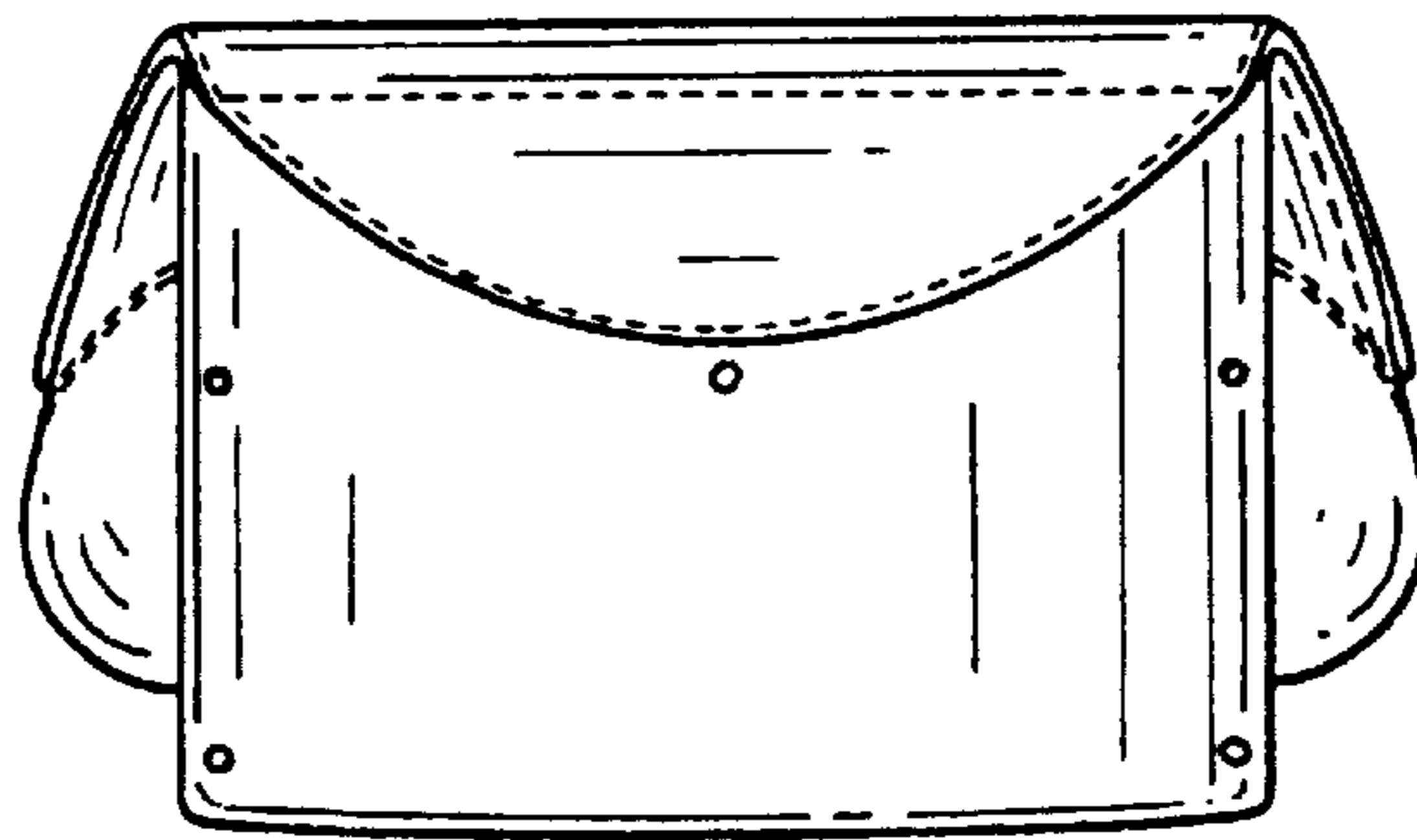

FIG. 4



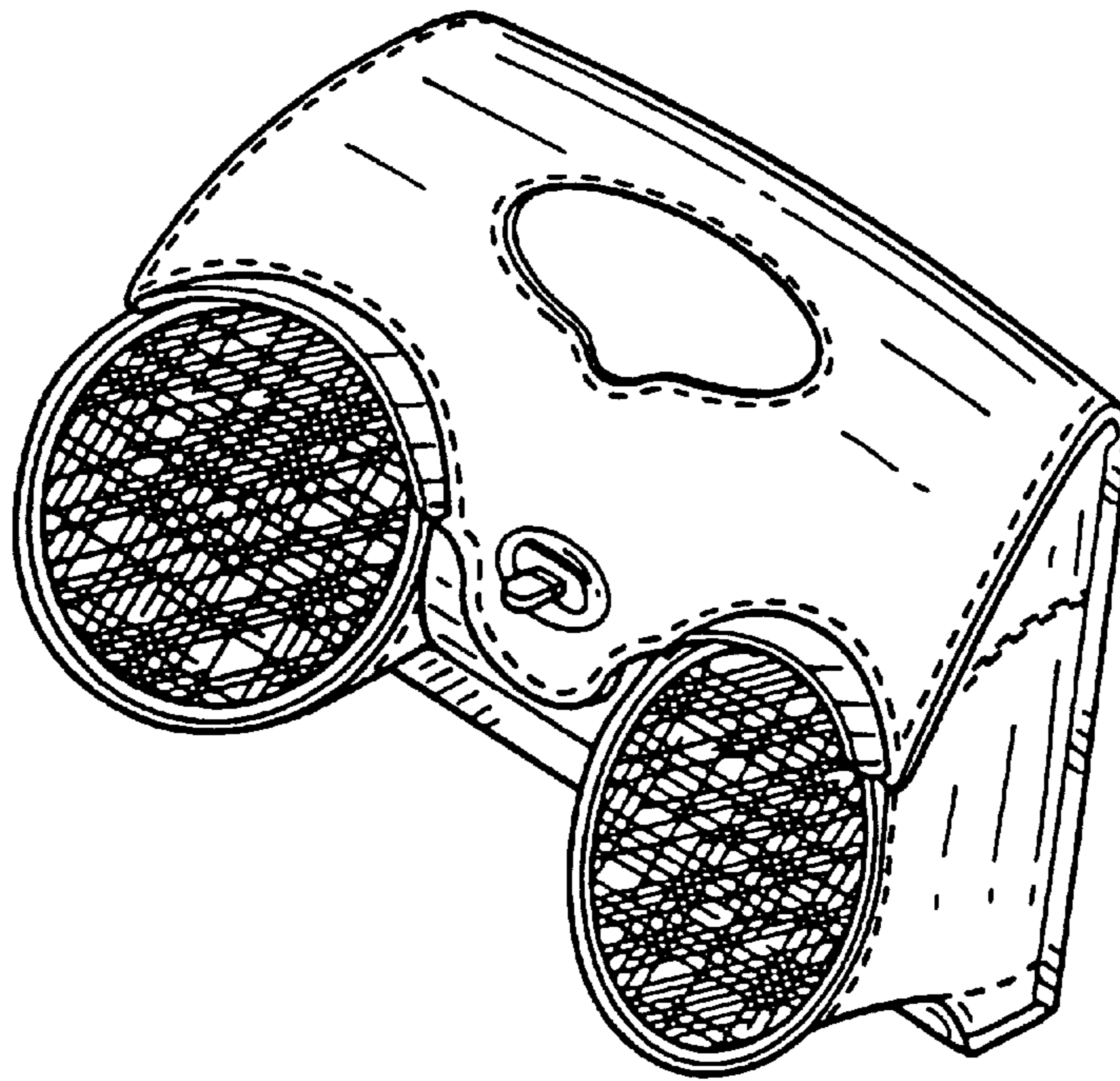

FIG. 6

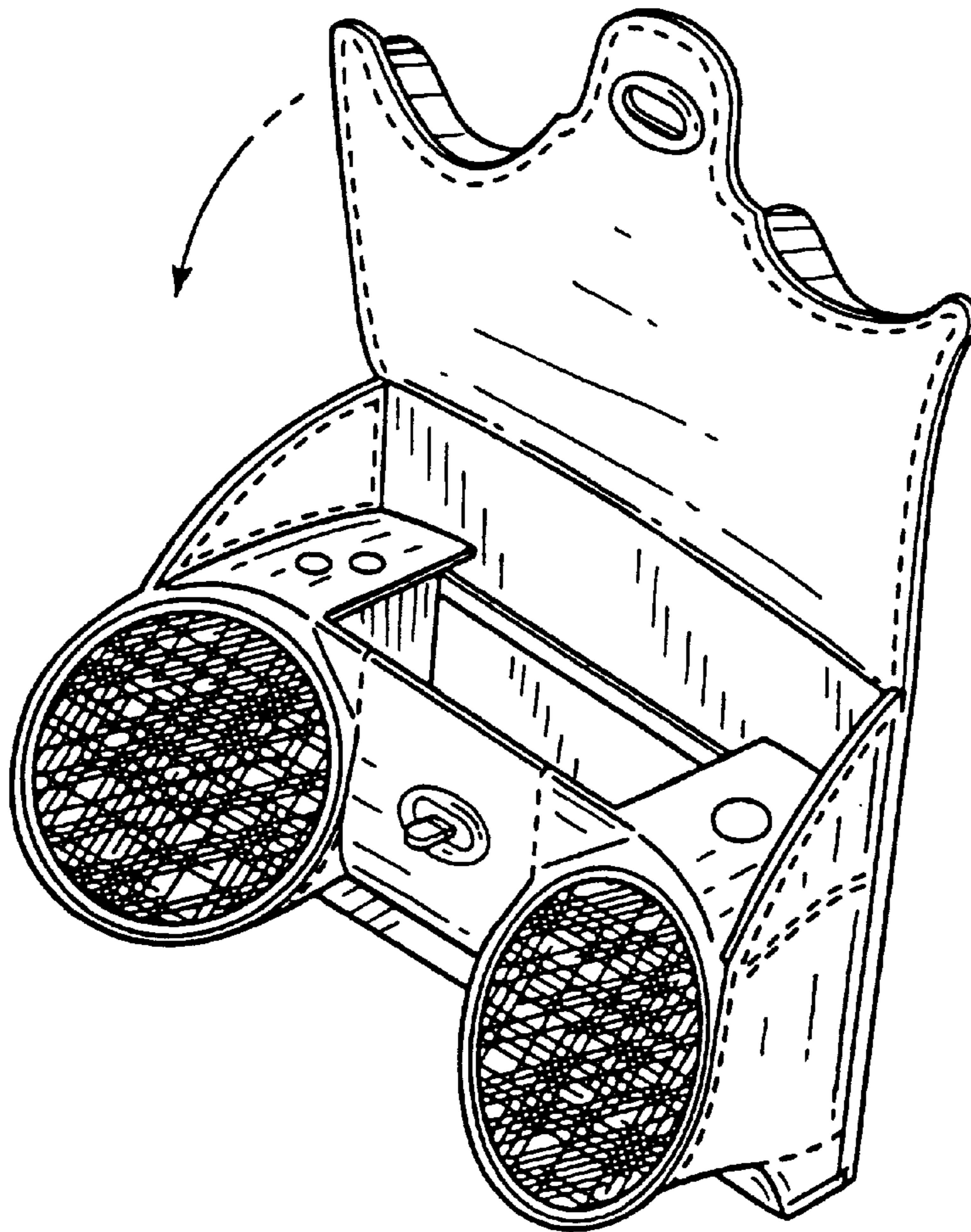

FIG. 7

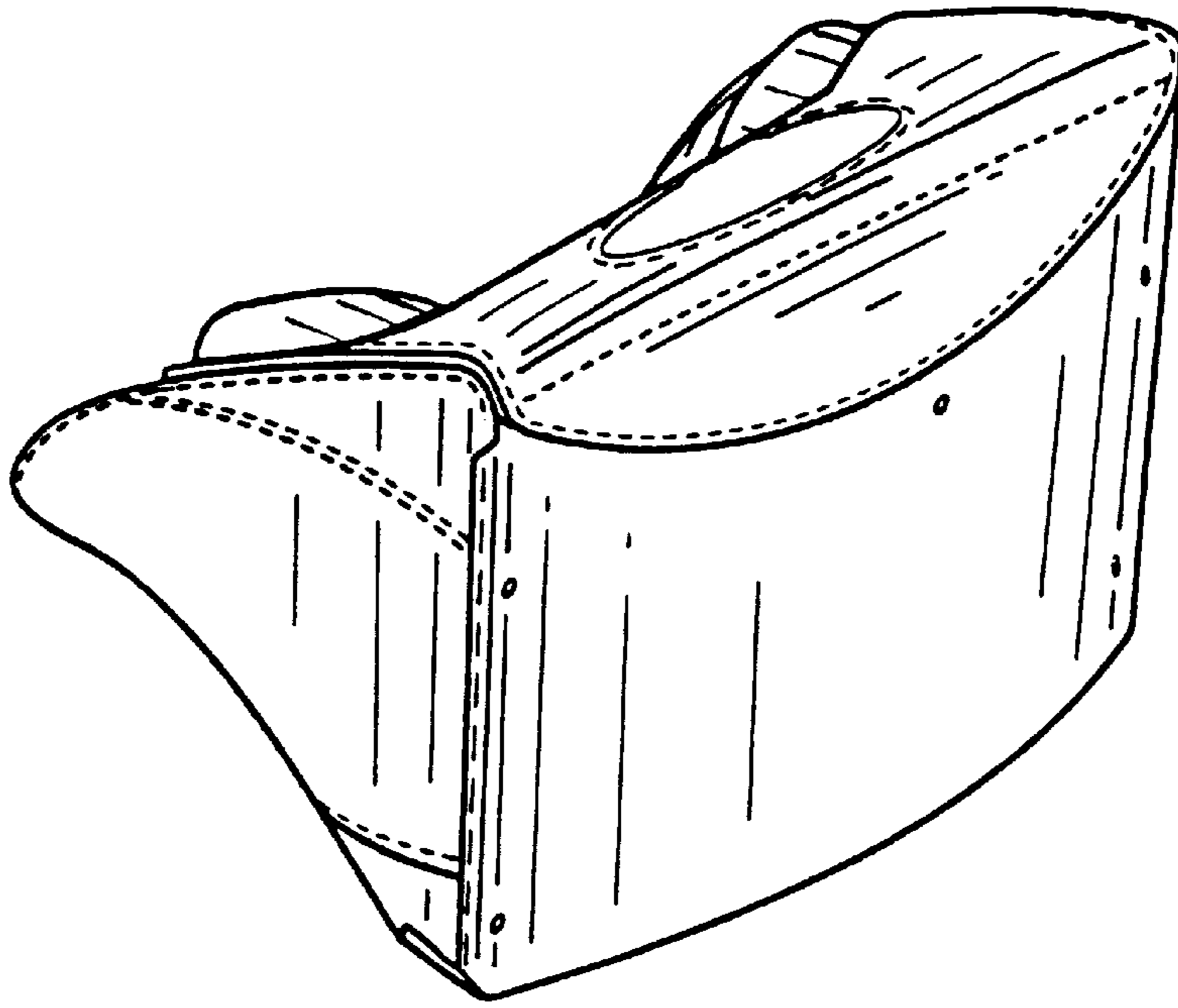

FIG. 8

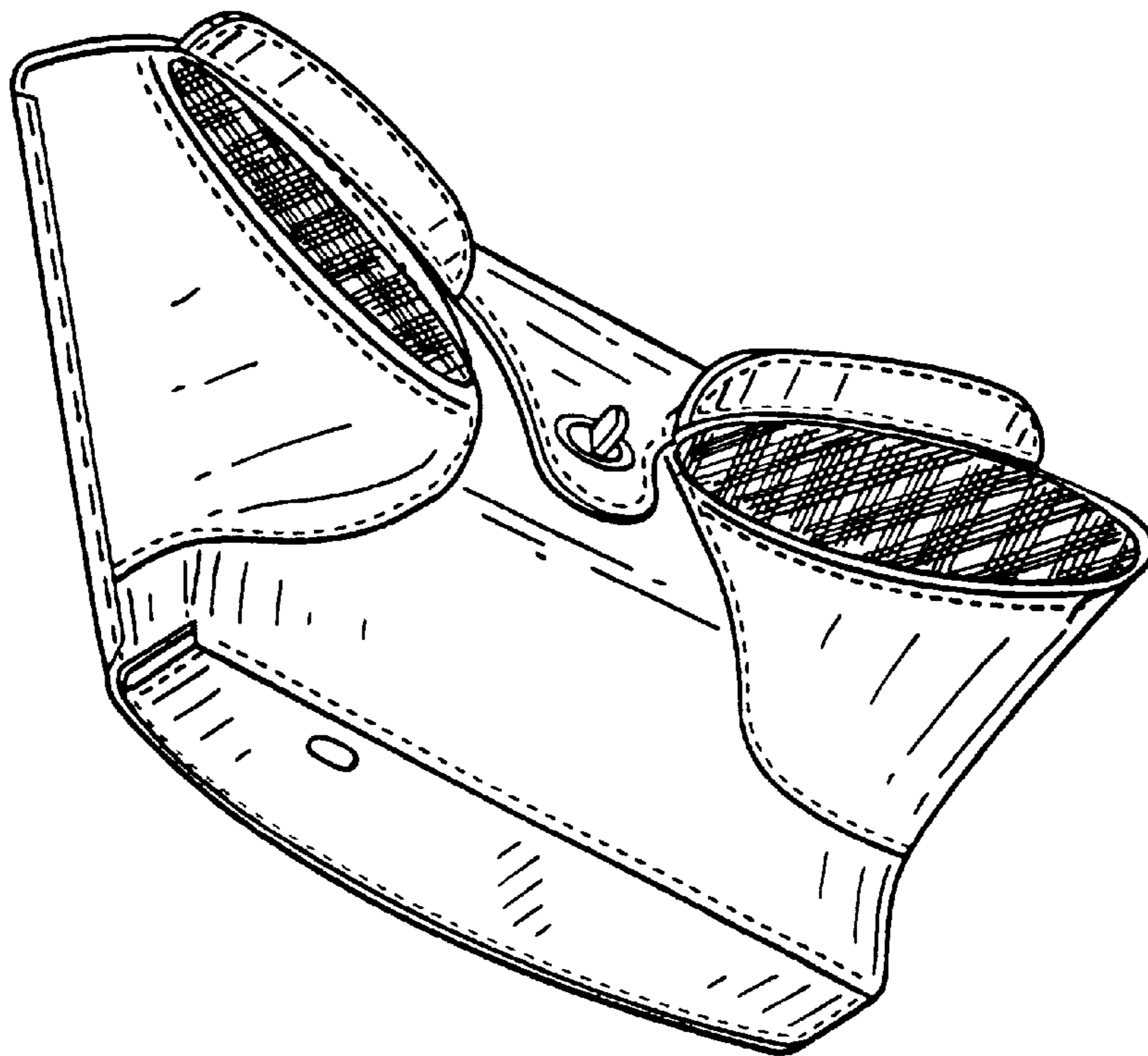

FIG. 9

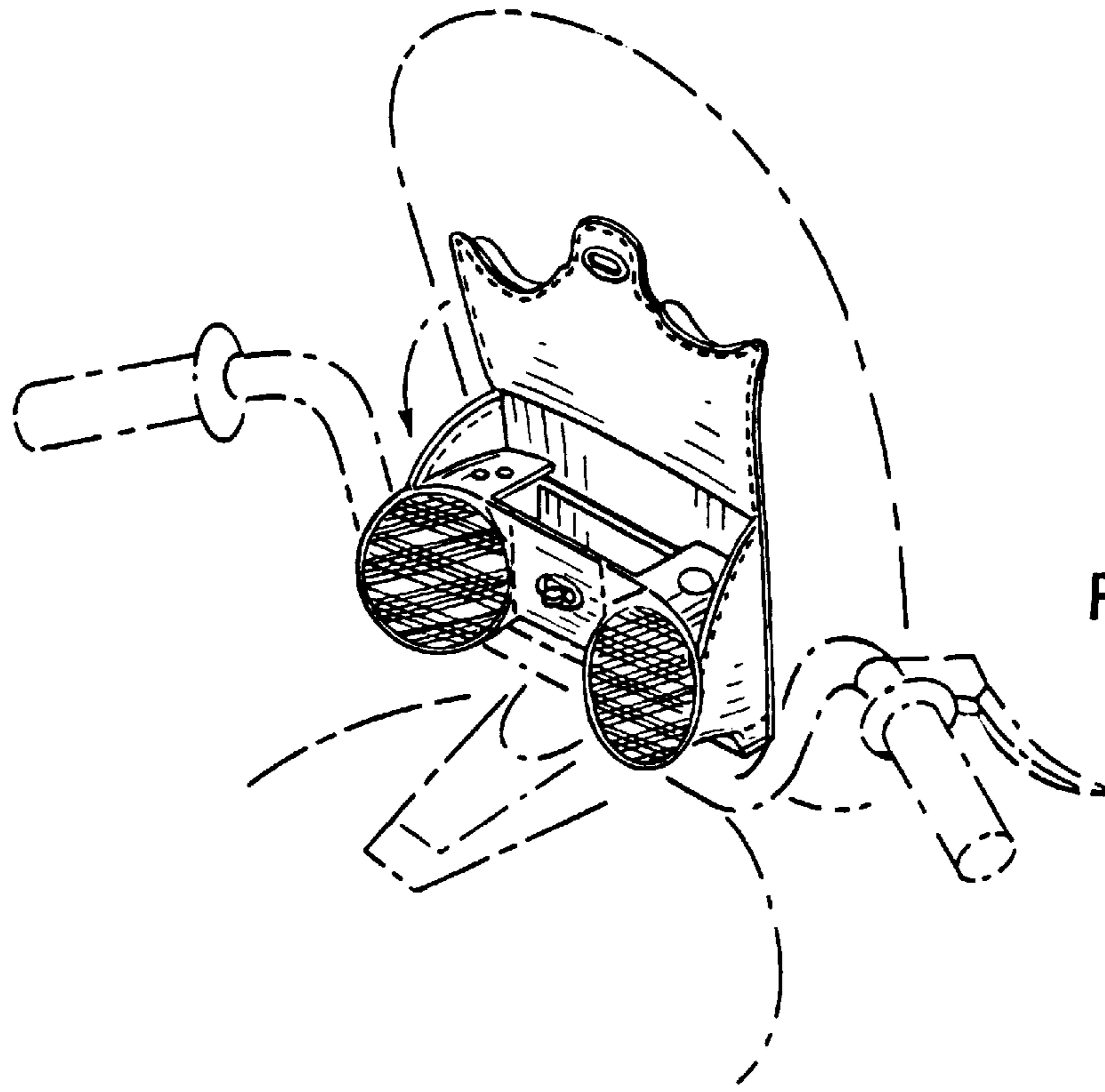

FIG. 10

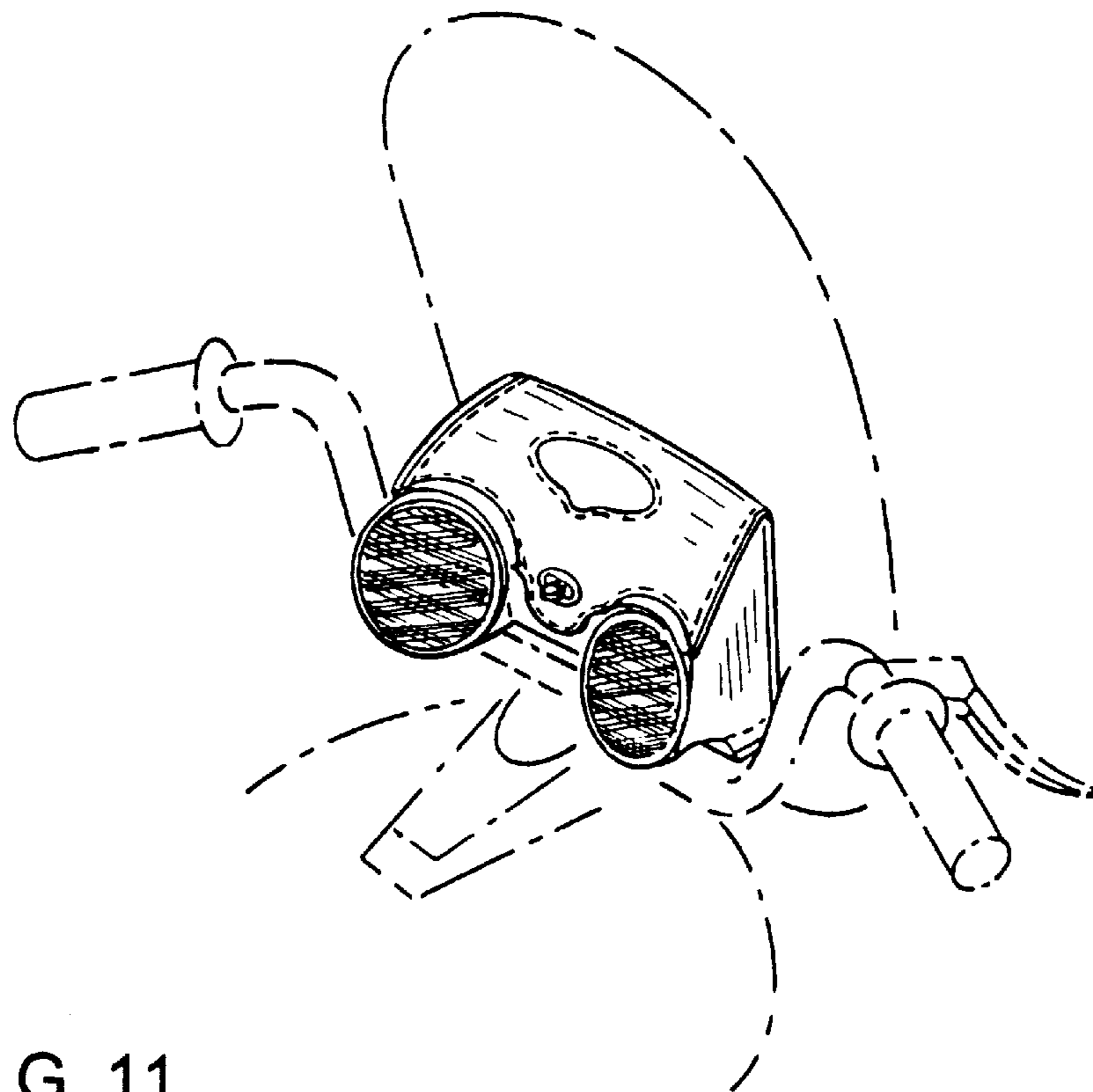

FIG. 11