



US00D461492S

(12) **United States Design Patent**  
**Bishop et al.**

(10) **Patent No.:** **US D461,492 S**

(45) **Date of Patent:** **\*\* Aug. 13, 2002**

(54) **PRINTER**

(75) **Inventors:** **David Carl Bishop**, Versailles; **John Paul Bradley**; **Joon Won Ha**, both of Lexington, all of KY (US)

(73) **Assignee:** **Lexmark International, Inc.**, Lexington, KY (US)

(\*\*) **Term:** **14 Years**

(21) **Appl. No.:** **29/144,003**

(22) **Filed:** **Jun. 22, 2001**

(51) **LOC (7) Cl.** ..... **14-02**

(52) **U.S. Cl.** ..... **D18/55**

(58) **Field of Search** ..... D18/36, 37, 50,  
D18/54-55; 400/691-694, 690.1-690.4,  
613.1-613.4, 613

(56) **References Cited**

**U.S. PATENT DOCUMENTS**

D293,113 S \* 12/1987 Foy ..... D18/54  
D353,155 S \* 12/1994 Stewart et al. .... D18/50

D374,030 S \* 9/1996 Horiki et al. .... D18/36  
D403,015 S \* 12/1998 Fetherolf ..... D18/55  
D425,552 S \* 5/2000 Kobayashi et al. .... D18/54  
D441,394 S \* 5/2001 Kobayashi et al. .... D18/54

\* cited by examiner

*Primary Examiner*—Cathy Anne MacCormac  
(74) *Attorney, Agent, or Firm*—John A. Brady

(57) **CLAIM**

The ornamental design for a printer, as shown and described.

**DESCRIPTION**

FIG. 1 is a top front, left side perspective view of a printer showing our new design;

FIG. 2 is a front elevational view thereof;

FIG. 3 is a left side elevational view thereof;

FIG. 4 is a right side elevational view thereof;

FIG. 5 is a top plan view thereof; and,

FIG. 6 is a rear elevational view thereof.

The bottom of this printer normally rests on a surface and is not seen nor intended to be seen as a part of our new design.

**1 Claim, 6 Drawing Sheets**

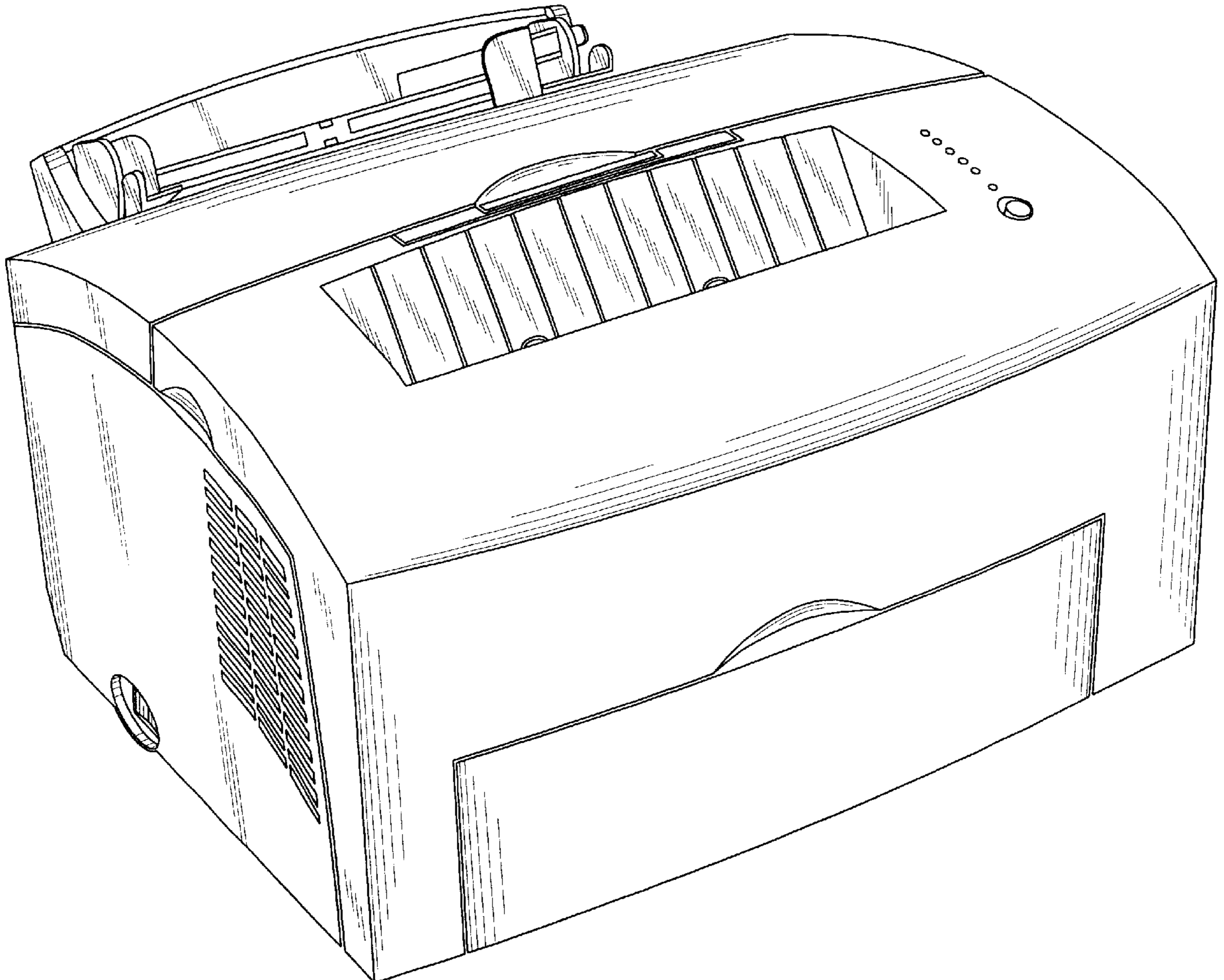

*FIG. 1*

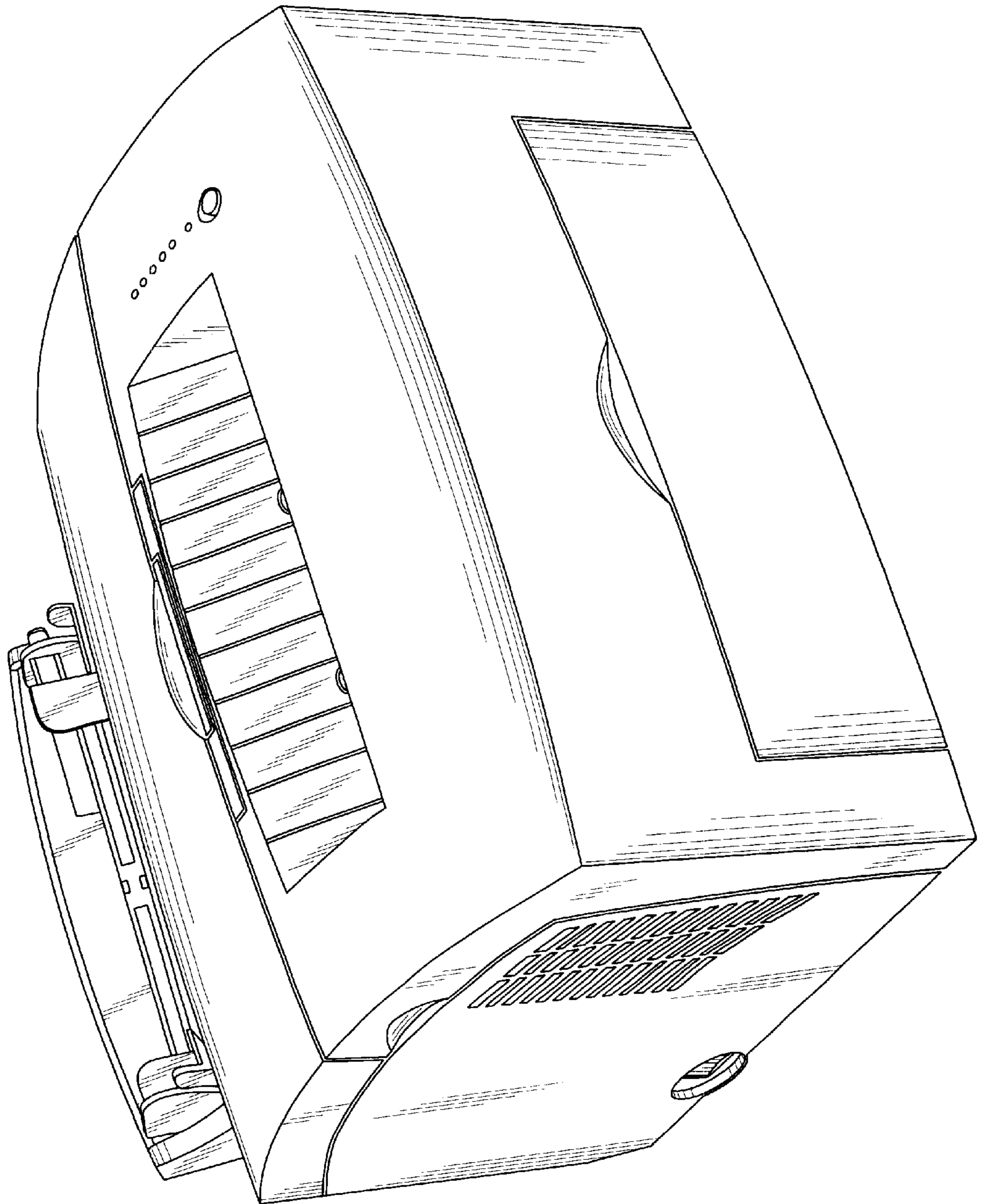

*FIG. 2*

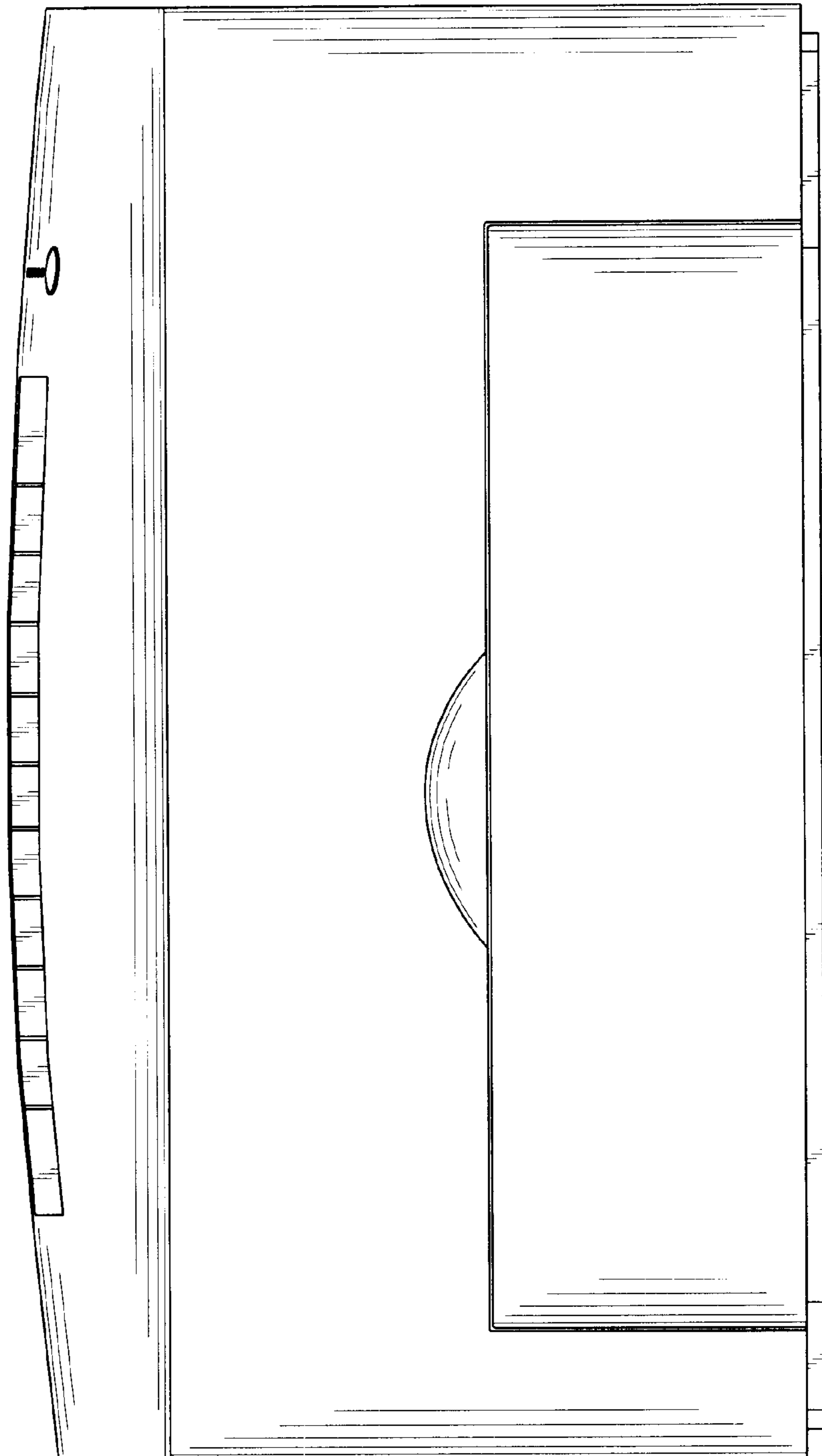

*FIG. 3*

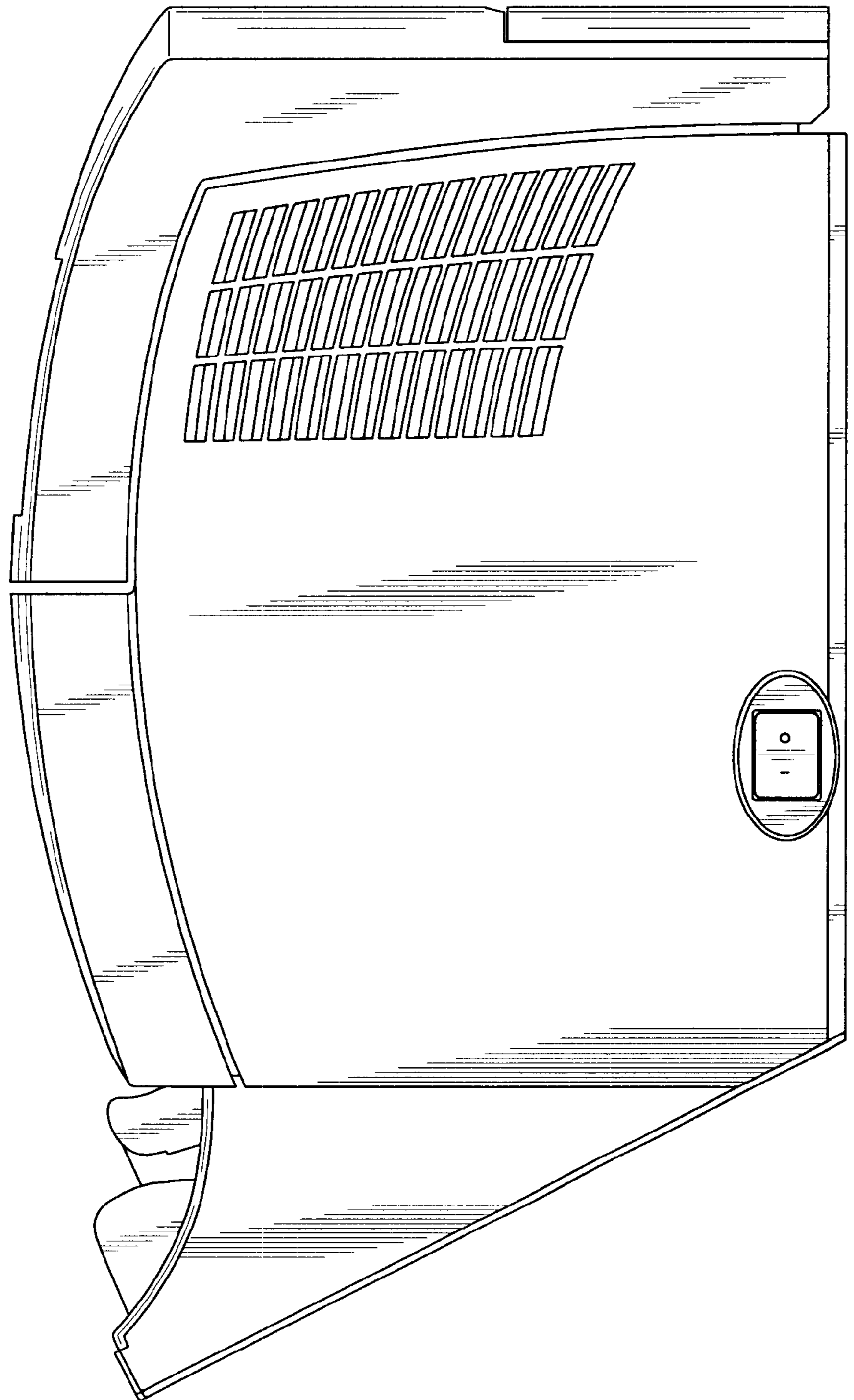

*FIG. 4*

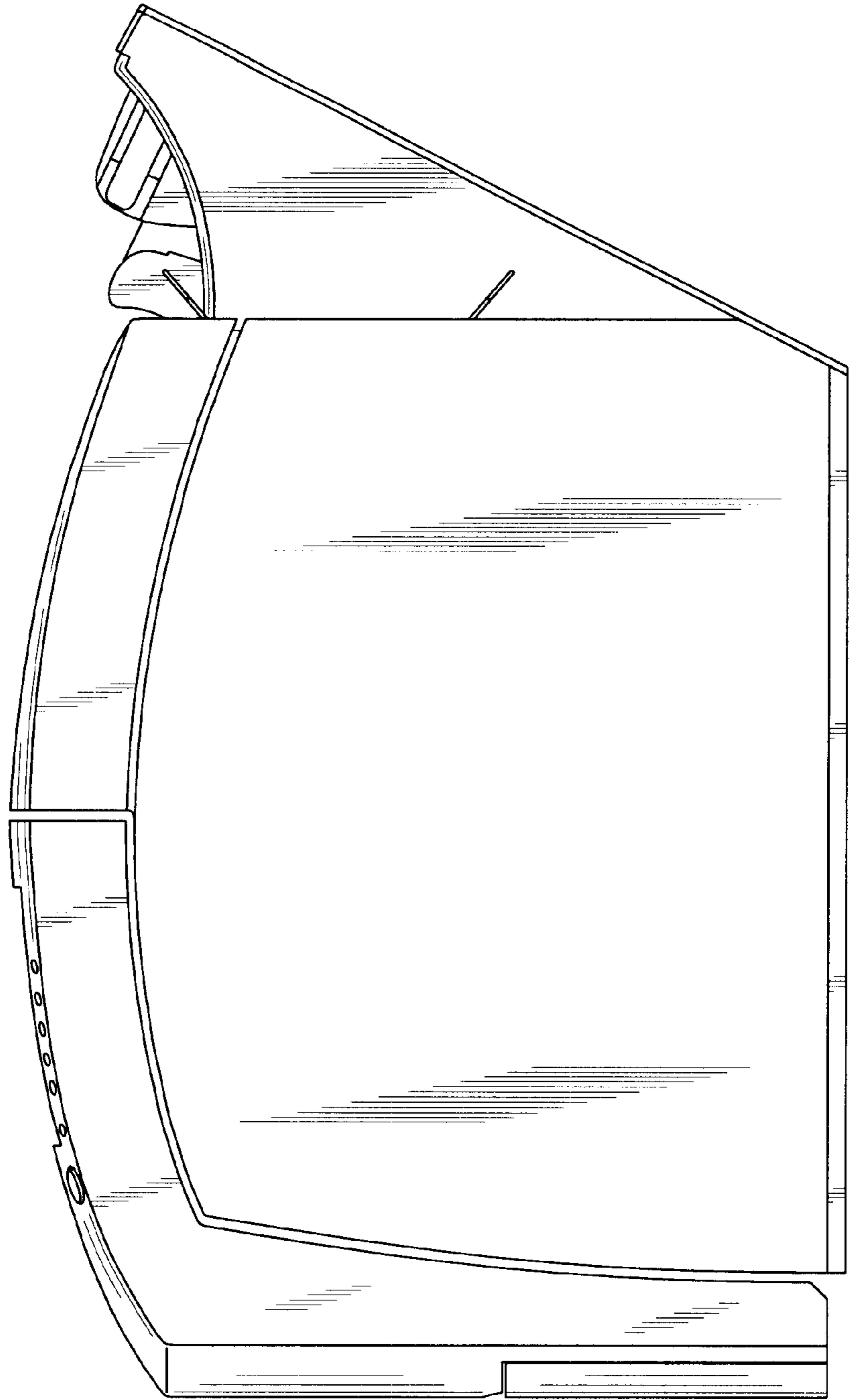

*FIG. 5*

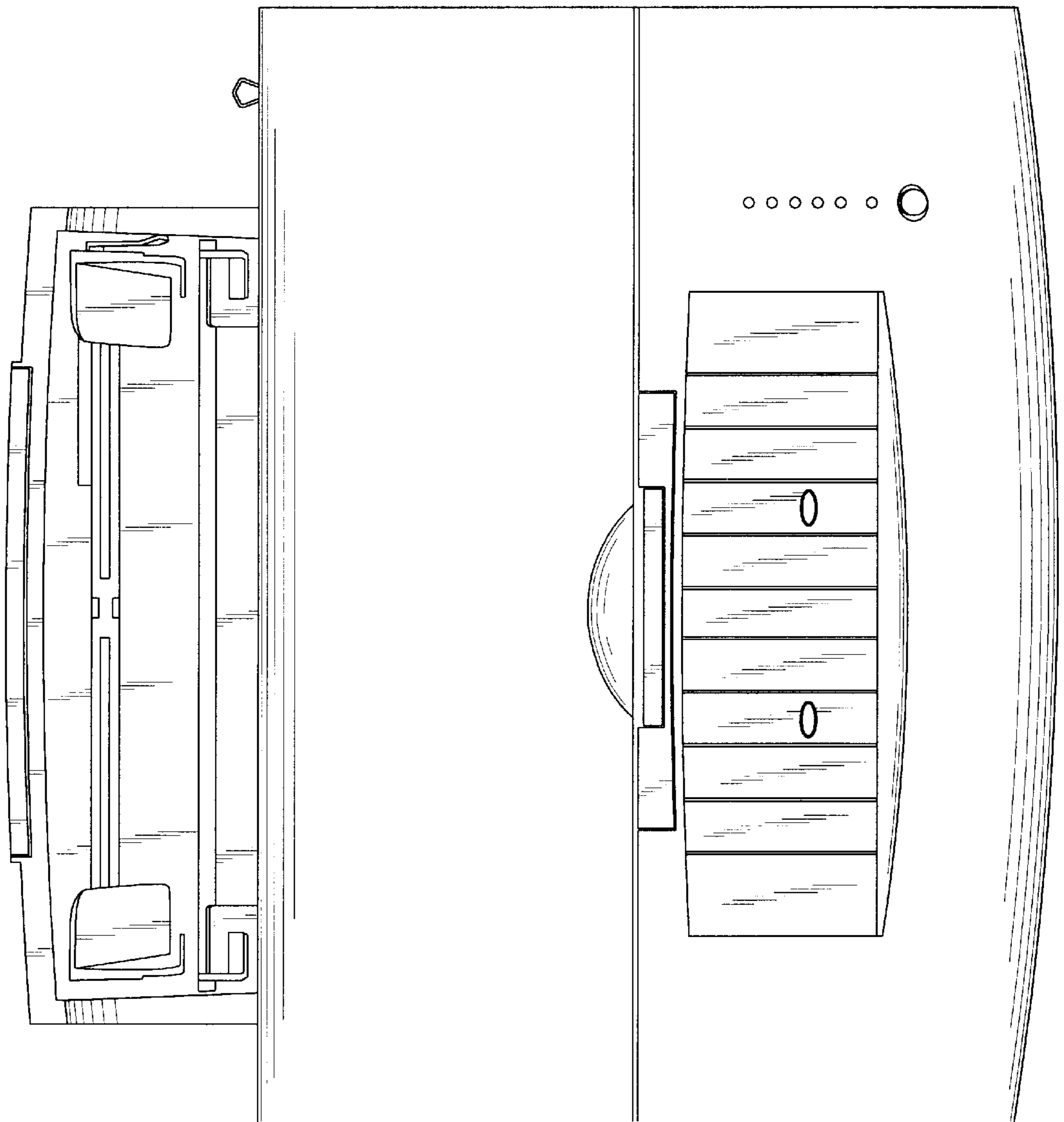

FIG. 6

