



US00D461444S

(12) **United States Design Patent**
Bernoni

(10) **Patent No.:** **US D461,444 S**

(45) **Date of Patent:** **** Aug. 13, 2002**

(54) **WHEEL FOR A MOTOR VEHICLE**

(75) Inventor: **Claudio Bernoni**, Selvazzano Dentro (IT)

(73) Assignee: **O.Z. S.p.A.**, Vicenza (IT)

(**) Term: **14 Years**

(21) Appl. No.: **29/150,492**

(22) Filed: **Nov. 23, 2001**

(30) **Foreign Application Priority Data**

May 24, 2001 (IT) BO0100027

(51) **LOC (7) Cl.** **12-16**

(52) **U.S. Cl.** **D12/211**

(58) **Field of Search** D12/204-211;
301/37.1, 64.1, 65

(56) **References Cited**

U.S. PATENT DOCUMENTS

D232,631 S	*	9/1974	Siroonian	D12/205
D232,827 S	*	9/1974	Siroonian	D12/205
D239,105 S	*	3/1976	Siroonian	D12/205
D253,286 S	*	10/1979	Lohmeyer	D12/205
D260,510 S	*	9/1981	Powers	D12/211
D277,471 S	*	2/1985	Uder	D12/211
D327,049 S	*	6/1992	Boyer	D12/211
D438,164 S	*	2/2001	Langerer	D12/211

* cited by examiner

Primary Examiner—Stacia Cadmus

(74) *Attorney, Agent, or Firm*—Fay, Sharpe, Fagan, Minnich & McKee, LLP

(57) **CLAIM**

The ornamental design for a wheel for a motor vehicle, as shown and described.

DESCRIPTION

FIG. 1 is a front perspective view of a wheel for a motor vehicle showing my design;

FIG. 2 is a front view of of the wheel for a motor vehicle shown in FIG. 1;

FIG. 3 is a front perspective view of a wheel for a motor vehicle showing a second embodiment of my design;

FIG. 4 is a front view of the wheel for a motor vehicle shown in FIG. 3;

FIG. 5 is a front perspective view of a wheel for a motor vehicle showing a third embodiment of my design;

FIG. 6 is a front view of the wheel for a motor vehicle shown in FIG. 5;

FIG. 7 is a front perspective view of a wheel for a motor vehicle showing a fourth embodiment of my design; and,

FIG. 8 is a front view of the wheel for a motor vehicle shown in FIG. 7.

The entire left side, right side, top, bottom and rear surfaces of all the embodiments of the wheel are not visible in their normal or intended use.

1 Claim, 4 Drawing Sheets

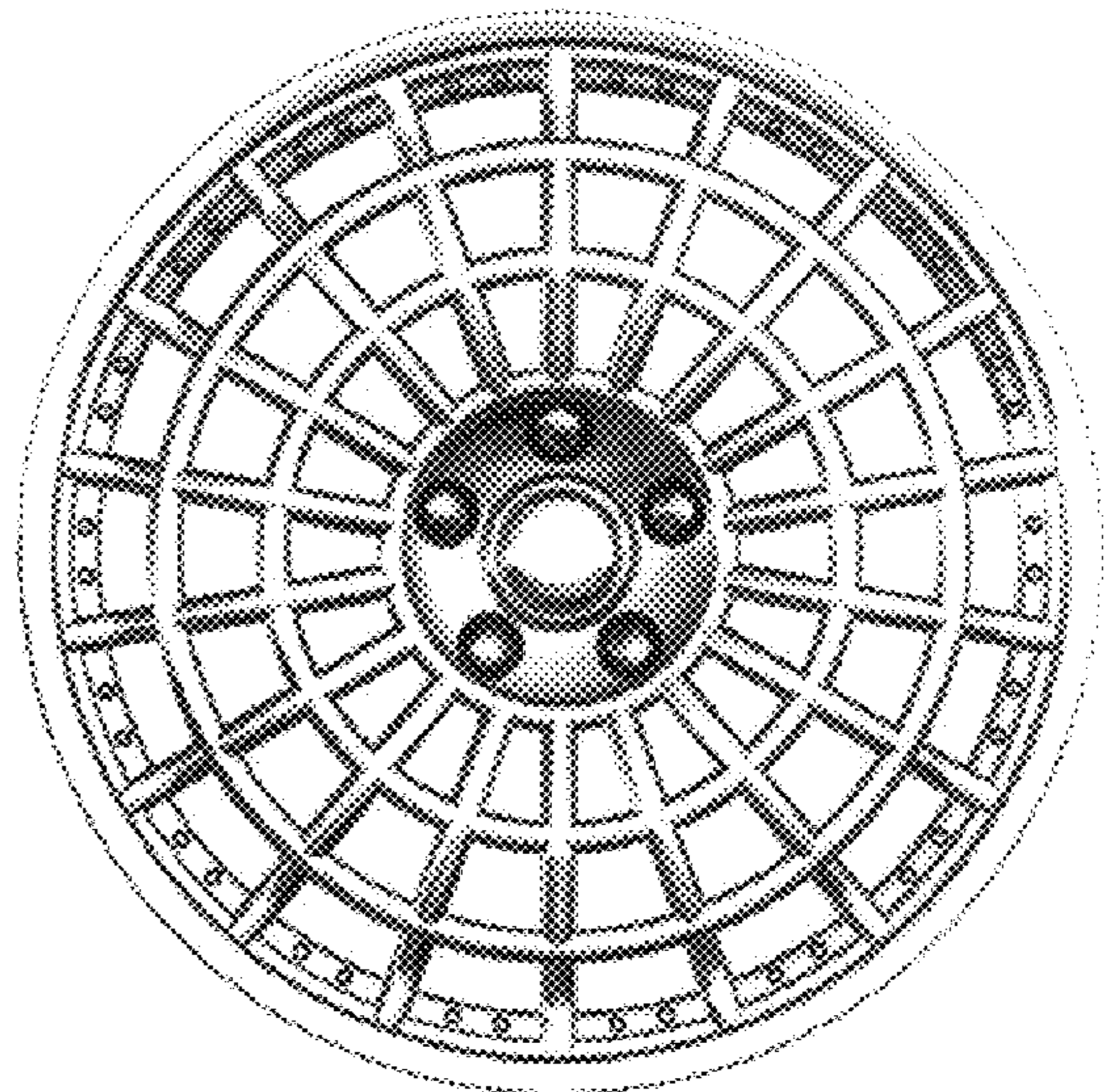
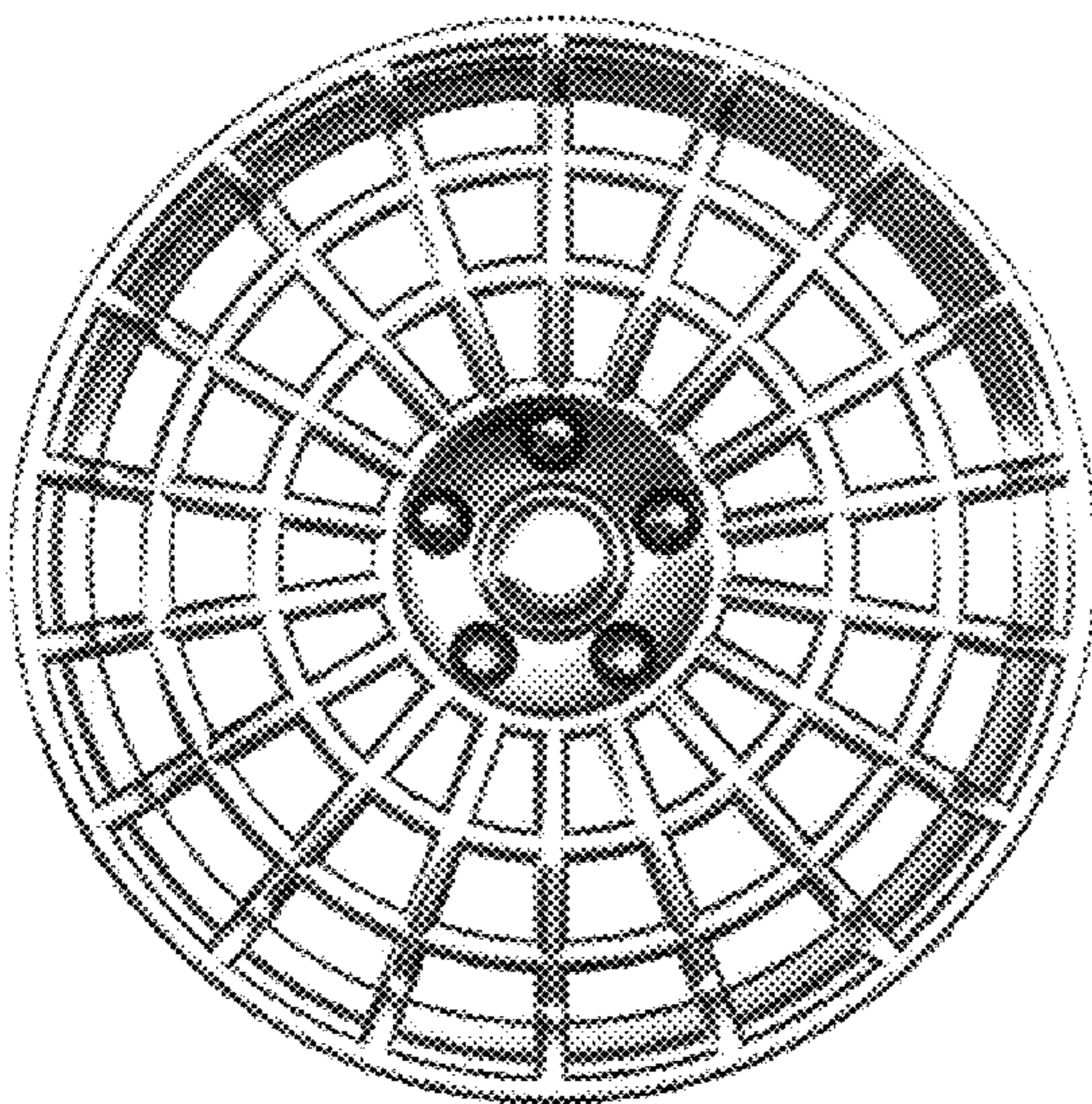

FIG. 1

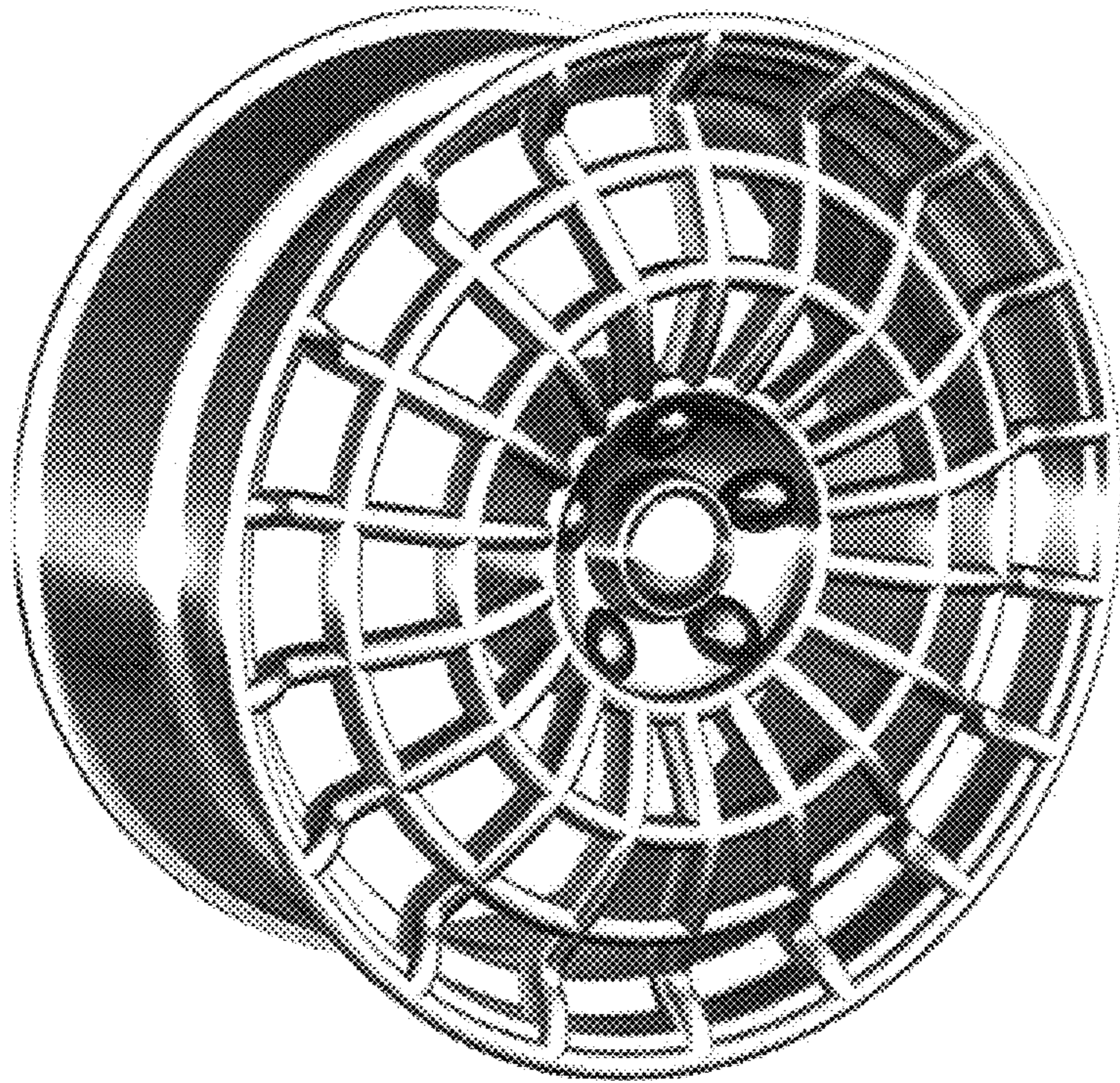

FIG. 2

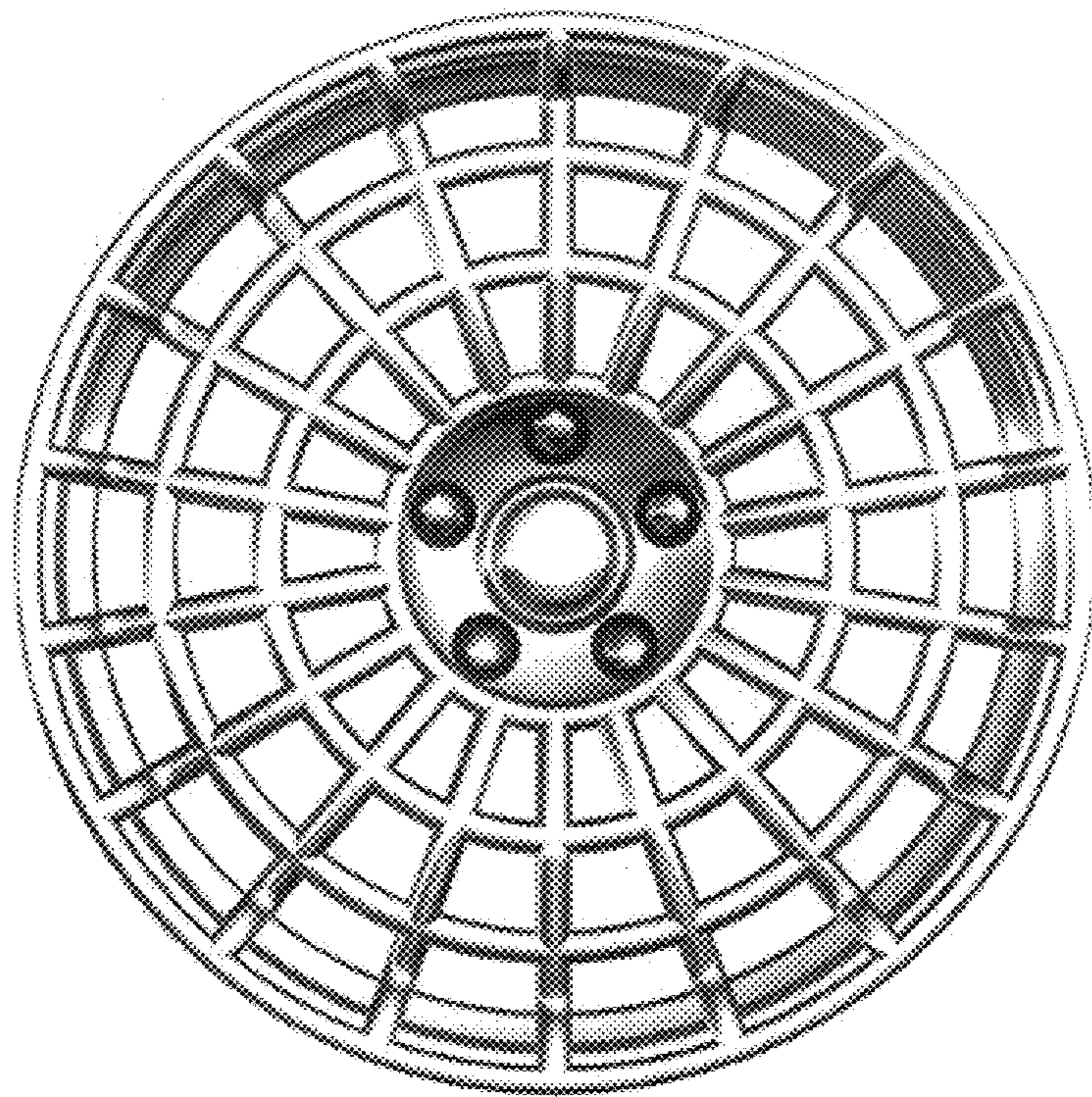

FIG.3

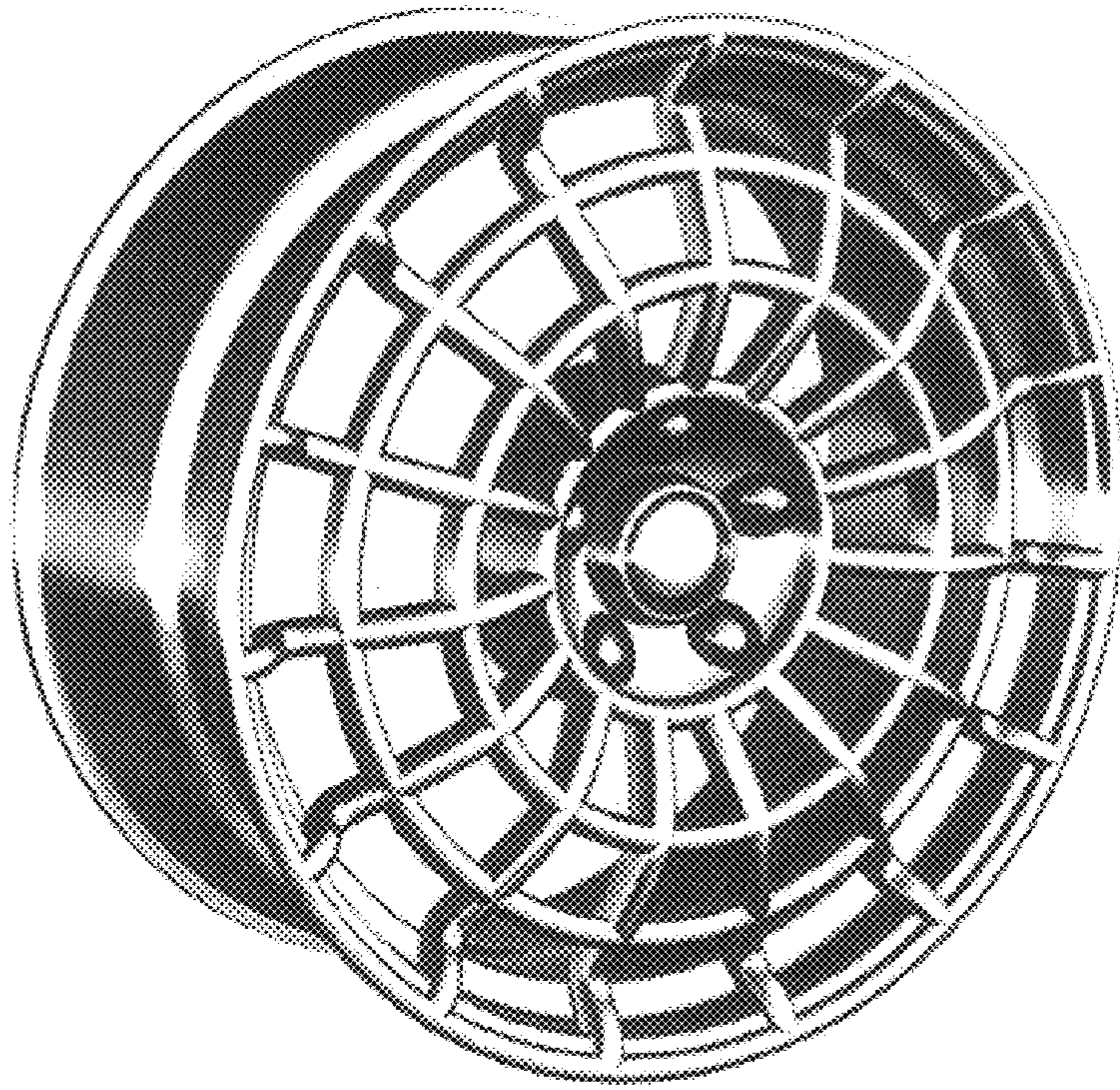

FIG.4

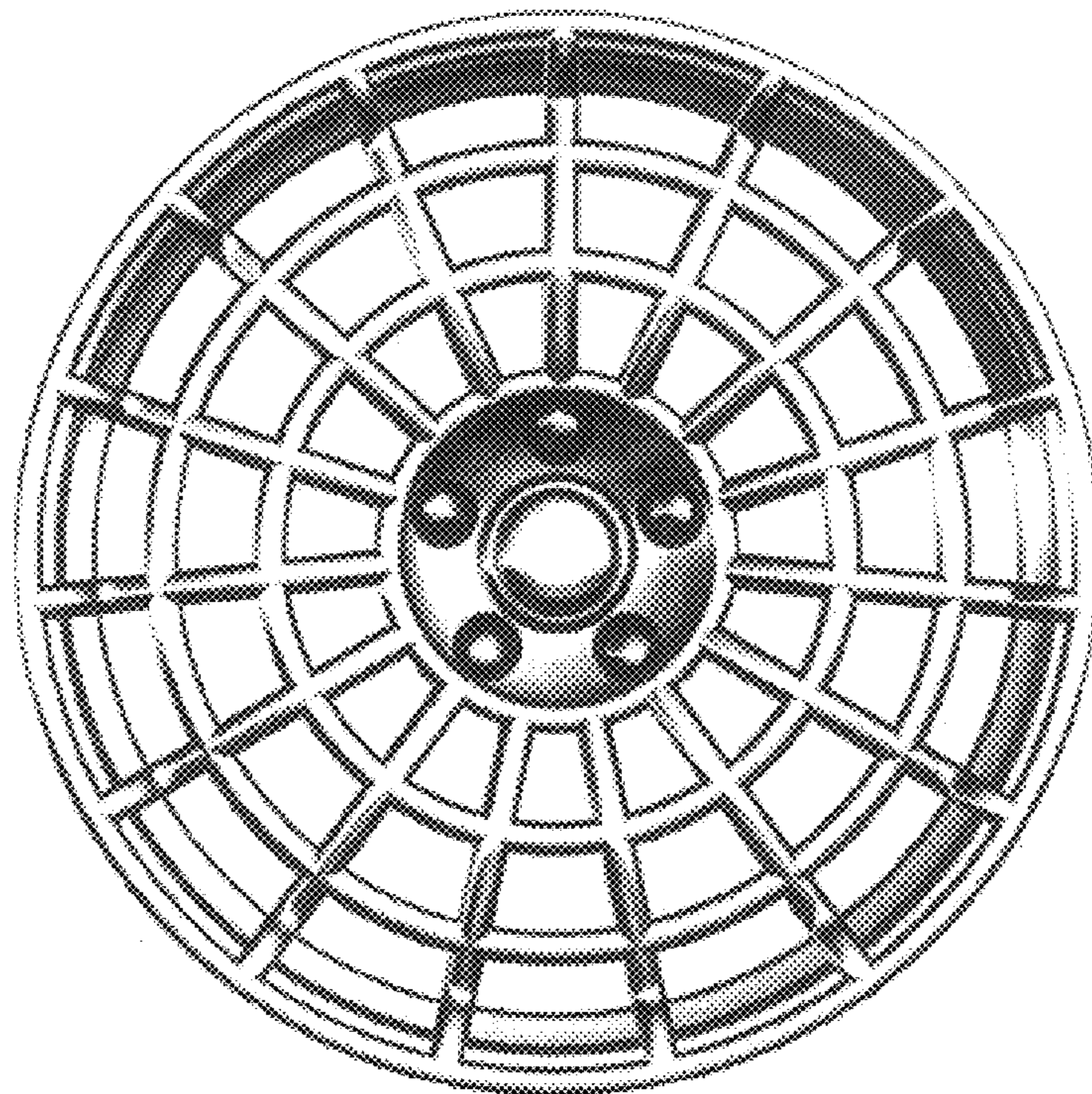

FIG. 5

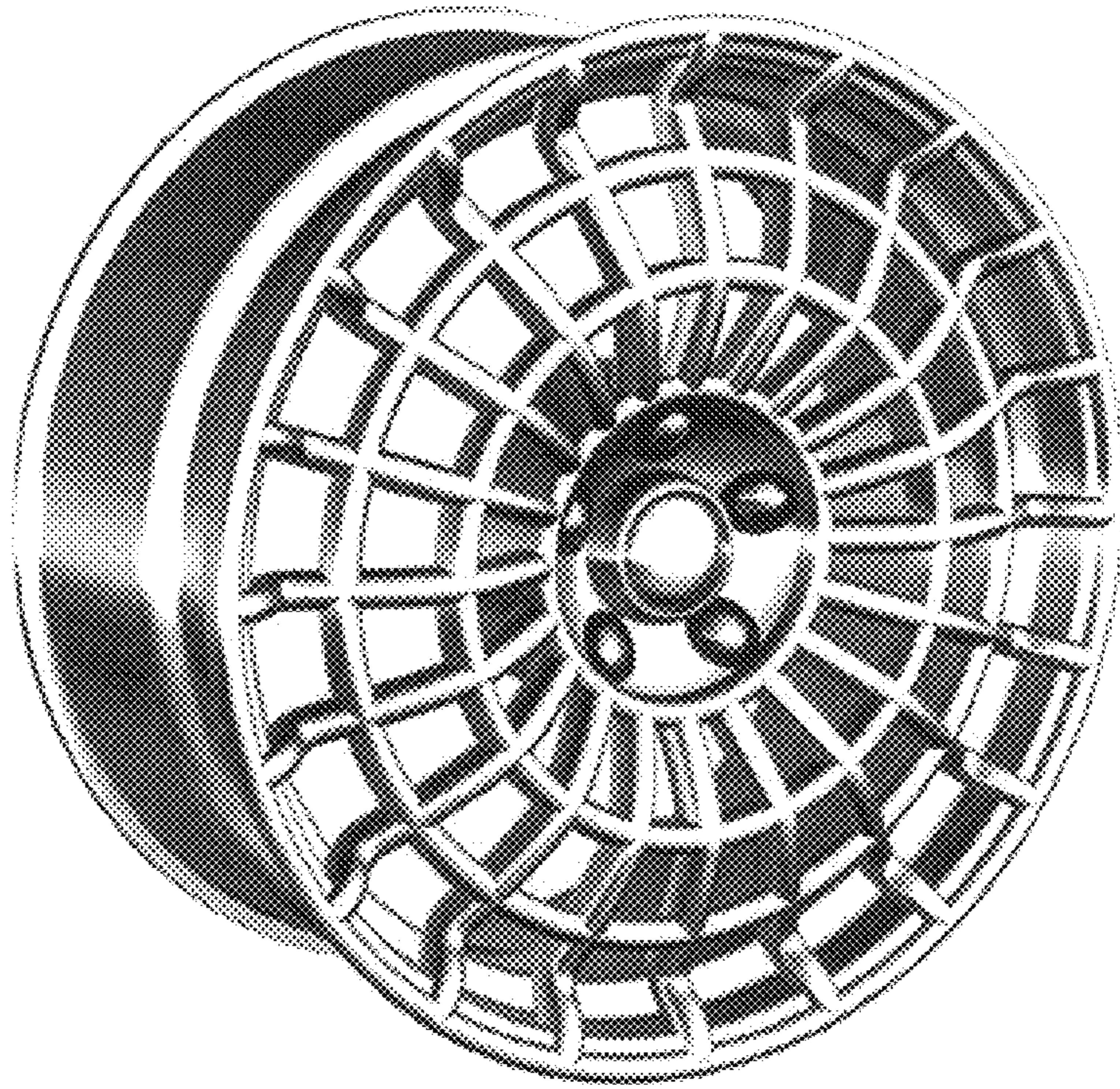

FIG. 6

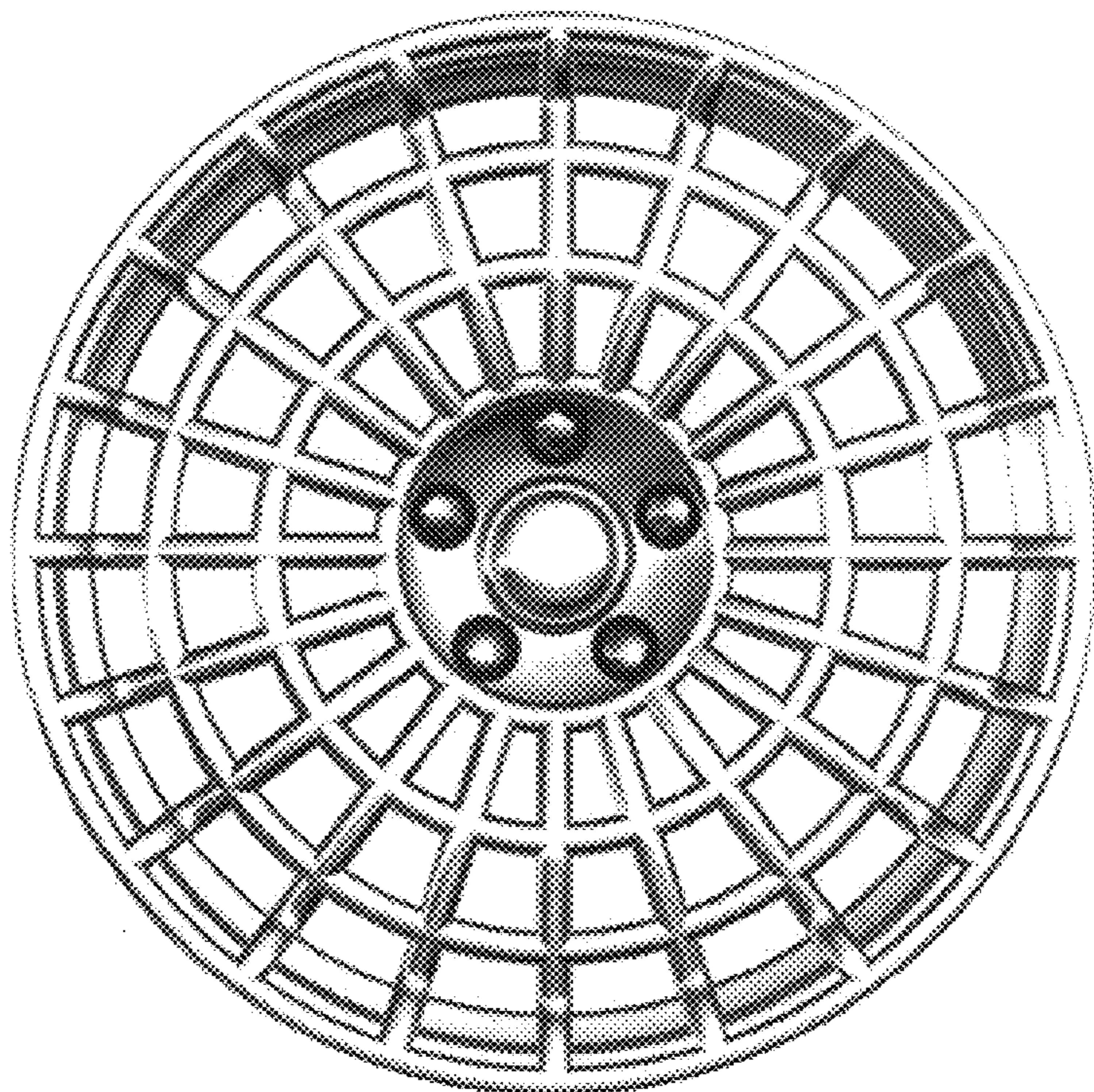

FIG. 7

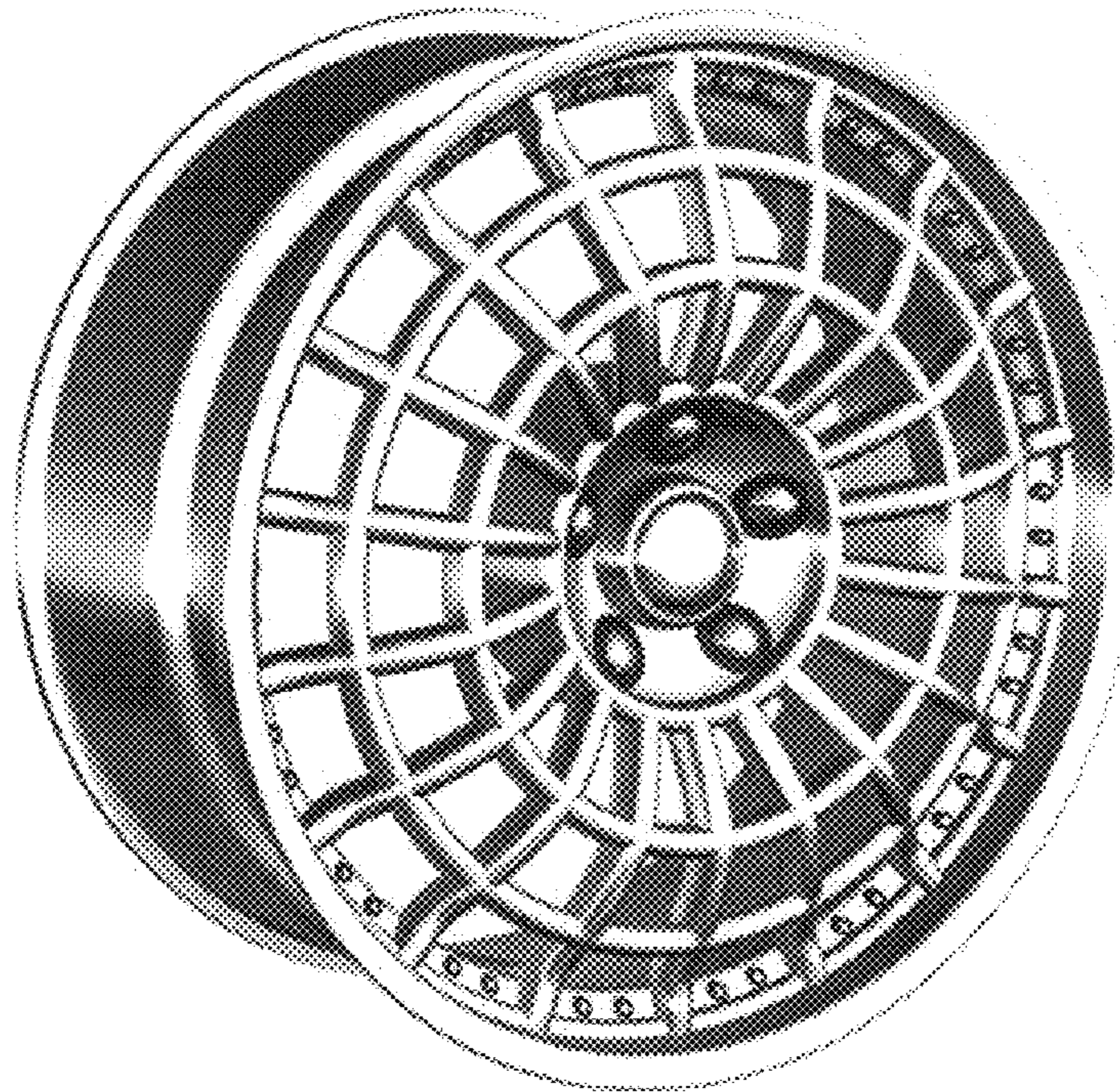

FIG. 8

