



US00D461436S

(12) **United States Design Patent**
Stickles et al.

(10) **Patent No.:** **US D461,436 S**
(45) **Date of Patent:** **** Aug. 13, 2002**

(54) **WHEEL FLARE FOR A SPORT UTILITY VEHICLE**

(75) Inventors: **George C. Stickles**, Thornton, CO (US);
Frank A. Borke, Lebanon, OH (US)

(73) Assignee: **Bestop, Inc.**, Broomfield, CO (US)

(**) Term: **14 Years**

(21) Appl. No.: **29/113,238**

(22) Filed: **Nov. 1, 1999**

(51) **LOC (7) Cl.** **12-16**

(52) **U.S. Cl.** **D12/190**

(58) **Field of Search** D12/190, 203,
D12/181, 168-169; 280/163, 160, 164.1,
414.1, 414.3, 828, 847-848

(56) **References Cited**

U.S. PATENT DOCUMENTS

D277,470 S	*	2/1985	Matti	D12/203
D293,311 S	*	12/1987	Strosek	D12/181 X
D307,413 S	*	4/1990	Bradley	D12/203
D336,885 S	*	6/1993	Hart et al.	D12/203
D374,419 S	*	10/1996	Thomas, Jr.	D12/203
D379,079 S	*	5/1997	Thomas, Jr.	D12/203
D383,710 S		9/1997	Guichard et al.		
D386,130 S	*	11/1997	Nielsen, III	D12/181 X
D387,016 S	*	12/1997	Nielsen, III	D12/181 X
D389,094 S		1/1998	Stollery		
D399,178 S	*	10/1998	Thomas, Jr.	D12/203
D402,611 S	*	12/1998	Thomas, Jr.	D12/203
D408,781 S		4/1999	Gordon		
5,947,546 A		9/1999	Hilliard et al.		

OTHER PUBLICATIONS

Steel Horse Catalog 1995.

* cited by examiner

Primary Examiner—Stacia Cadmus

(74) *Attorney, Agent, or Firm*—W. Scott Carson

(57) **CLAIM**

The ornamental design for a wheel flare for a sport utility vehicle, as shown and described.

DESCRIPTION

FIG. 1 is a perspective view of a wheel flare for a sport utility vehicle, showing our new design, it being understood that broken line disclosure of the car is for illustrative purposes and forms no part of the claimed design;

FIG. 2 is an enlarged right side view thereof;

FIG. 3 is a front elevational view of FIG. 2;

FIG. 4 is a rear elevational view of FIG. 2;

FIG. 5 is a top plan view of FIG. 2;

FIG. 6 is a left side elevational view of FIG. 2;

FIG. 7 is a bottom plan view of FIG. 2;

FIG. 8 is a section view taken along line 8—8 in FIG. 6;

FIG. 9 is a right side elevational view of a second embodiment of a wheel flare for a sport utility vehicle, showing our new design;

FIG. 10 is a front elevational view of FIG. 9;

FIG. 11 is a rear elevational view of FIG. 9;

FIG. 12 is a top plan view of FIG. 9;

FIG. 13 is a left side elevational view of FIG. 9;

FIG. 14 is a bottom plan view of FIG. 9; and,

FIG. 15 is a section view taken along 15—15 in FIG. 13.

1 Claim, 5 Drawing Sheets

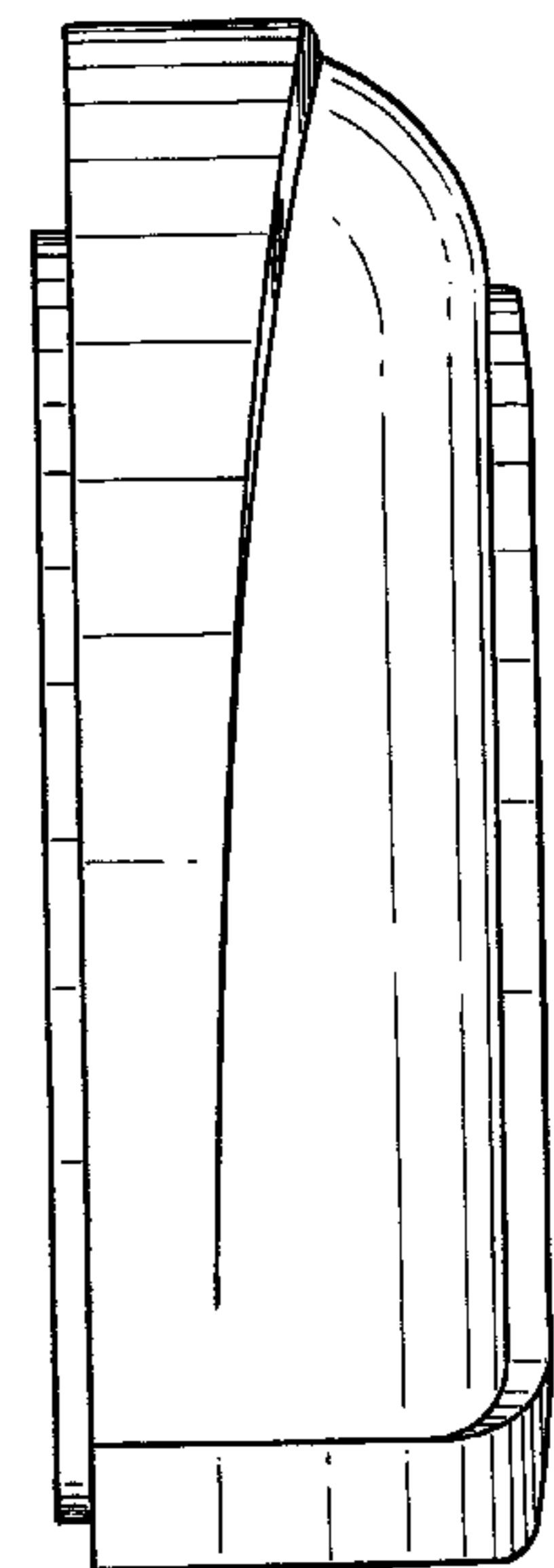
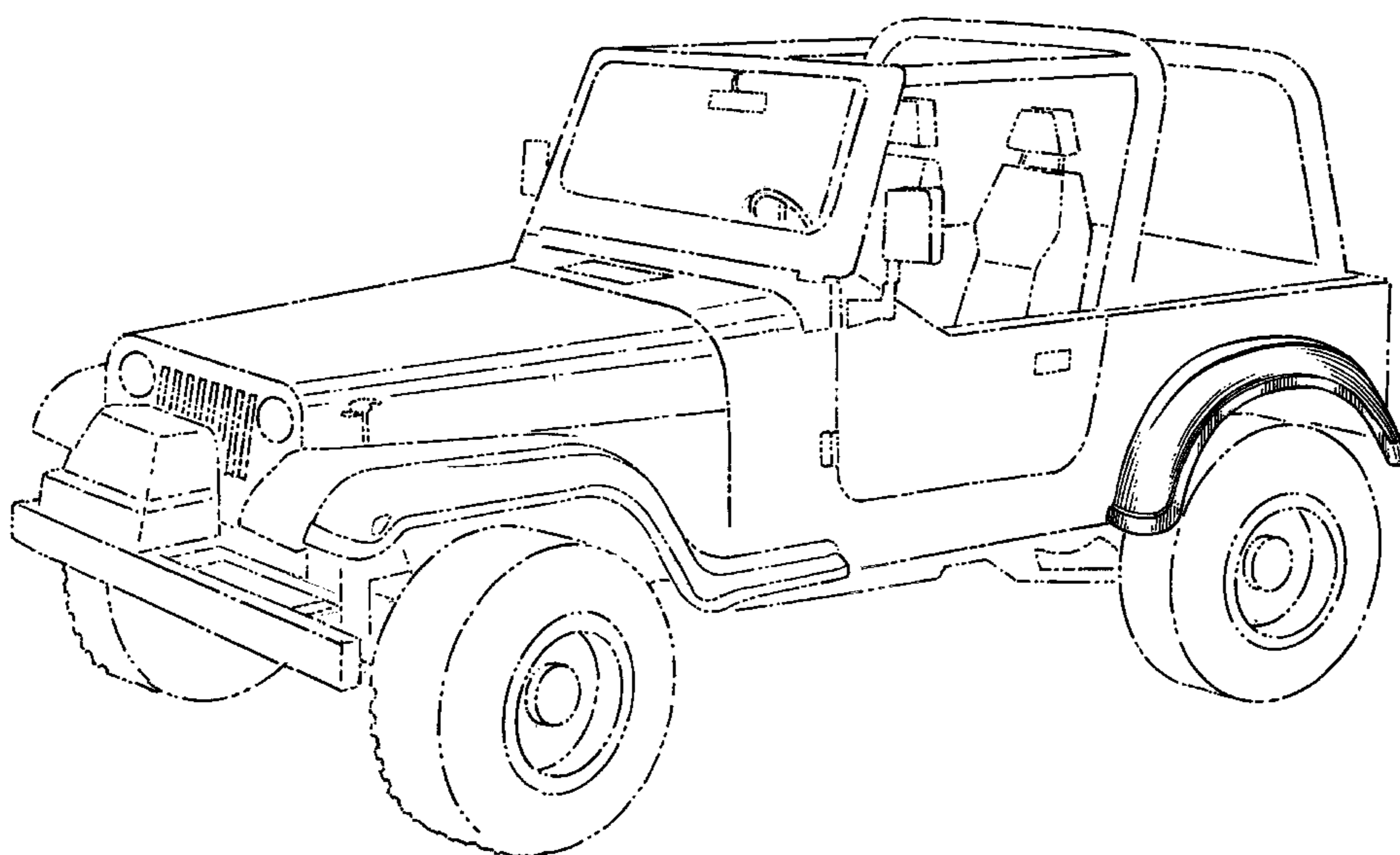

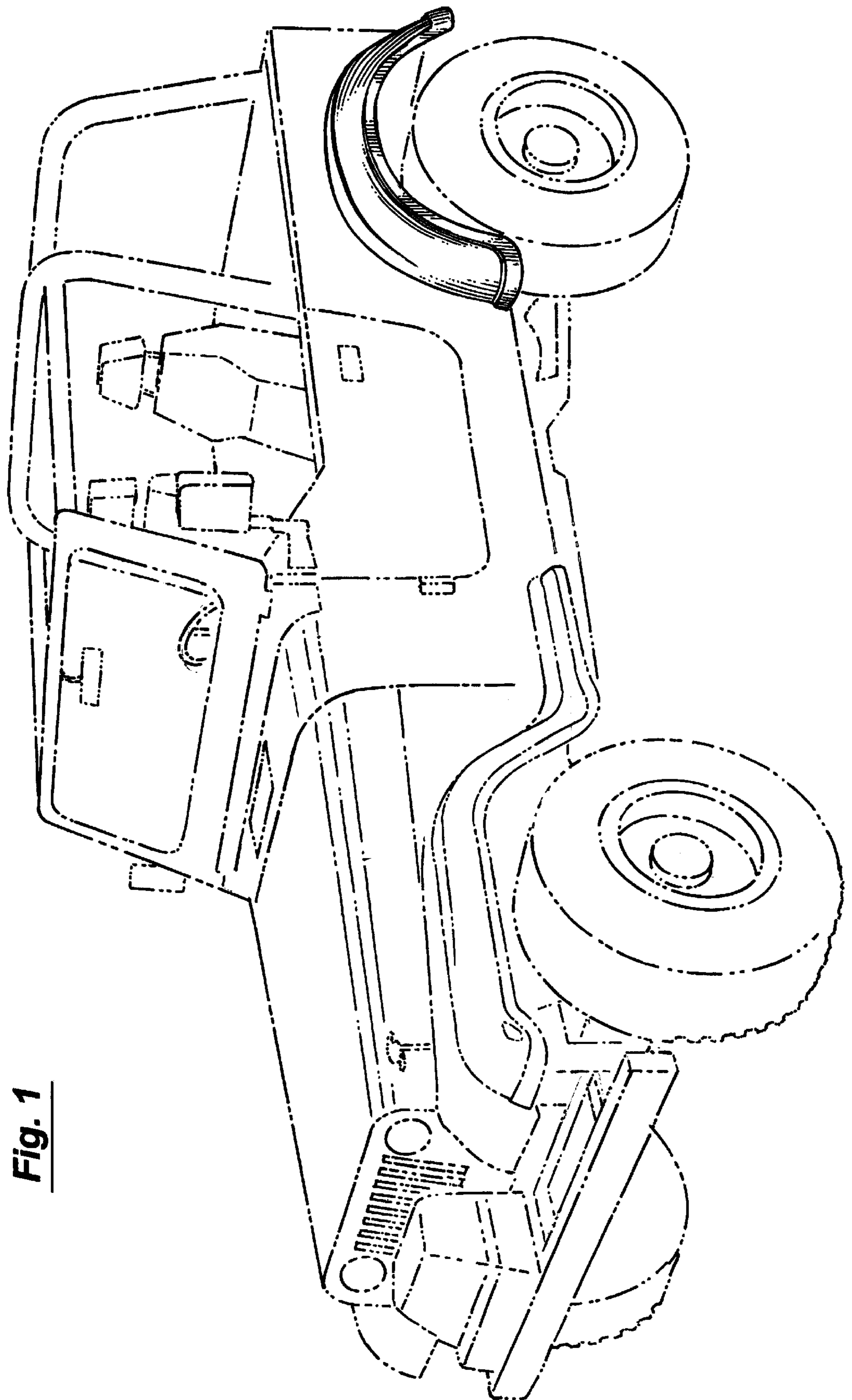

Fig. 1

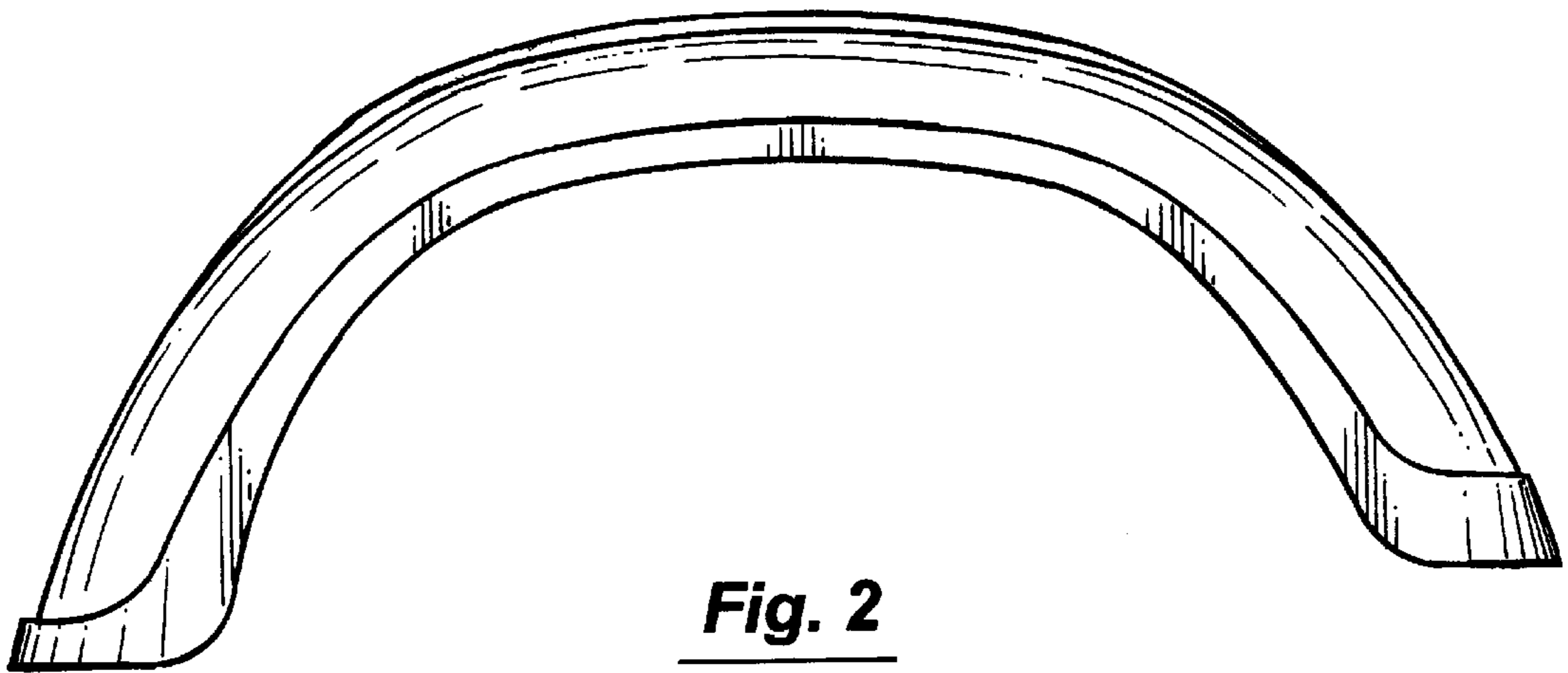

Fig. 2

Fig. 3

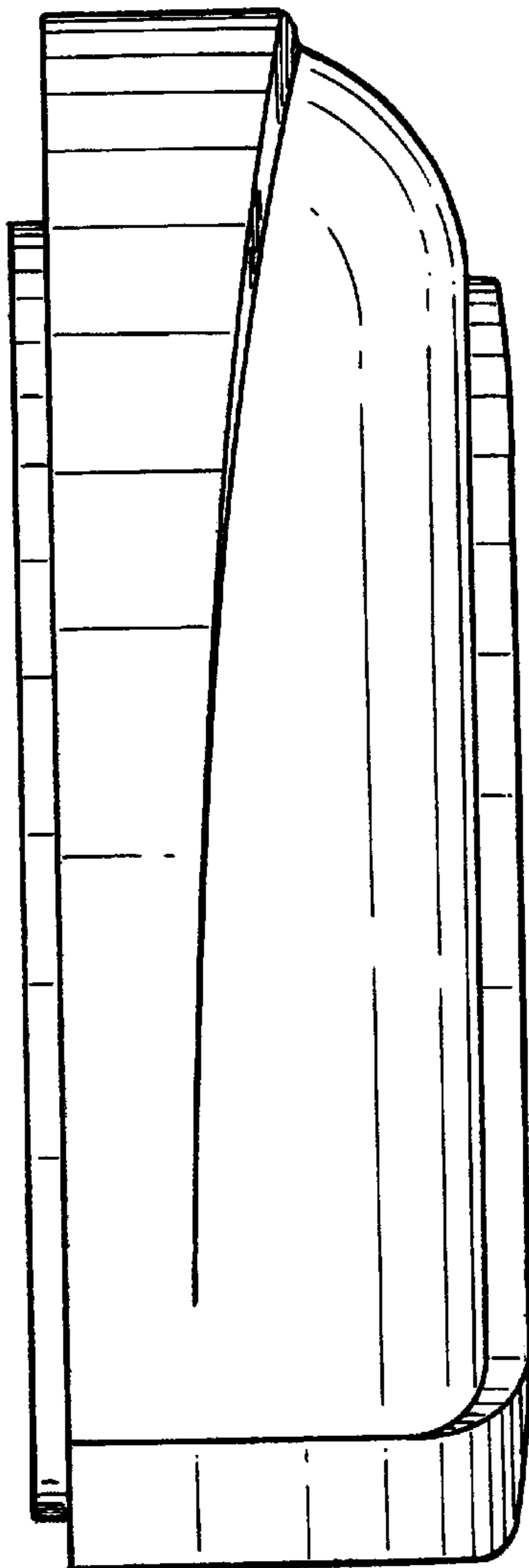

Fig. 4

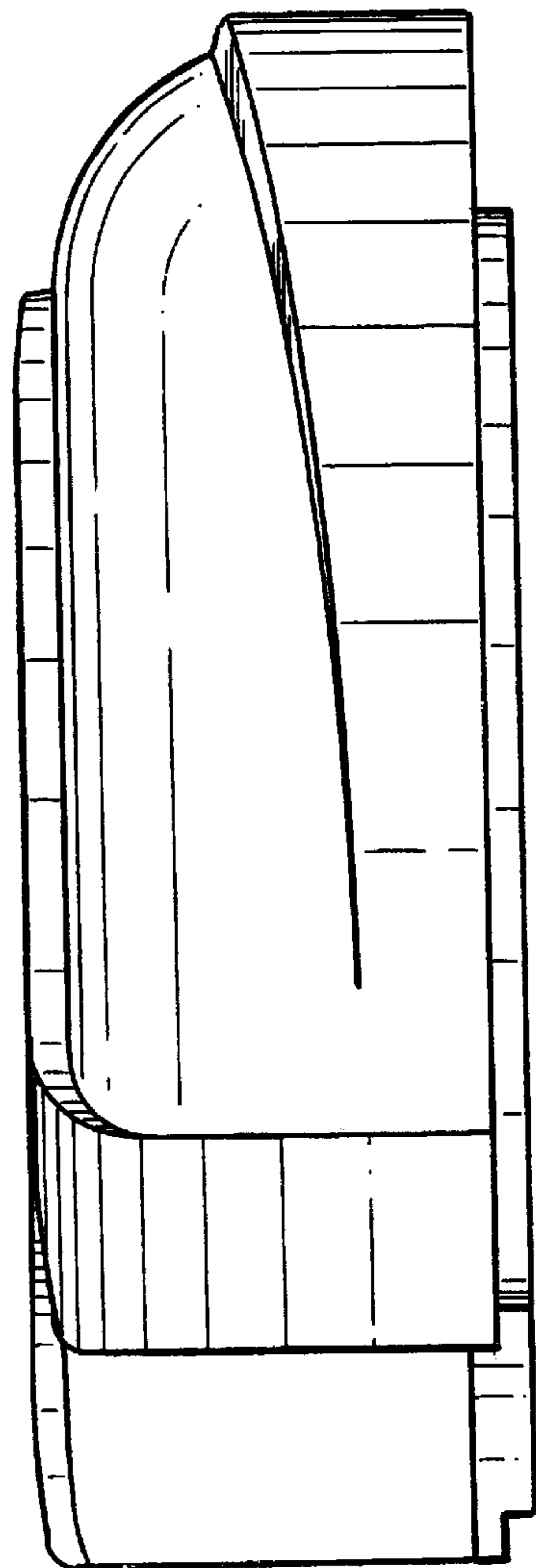

Fig. 5

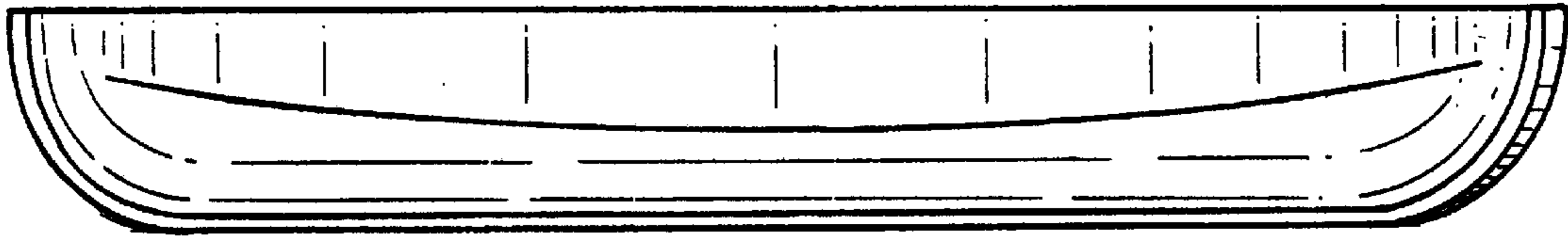

Fig. 6

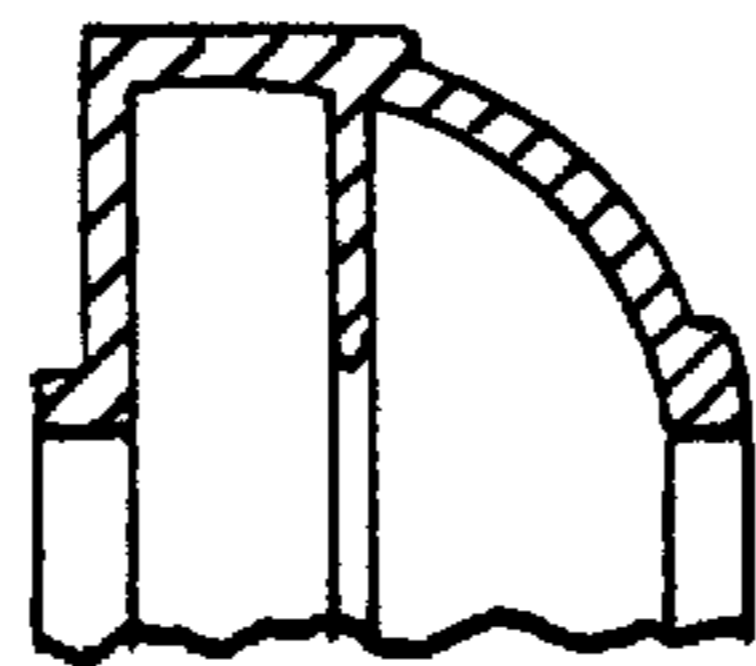
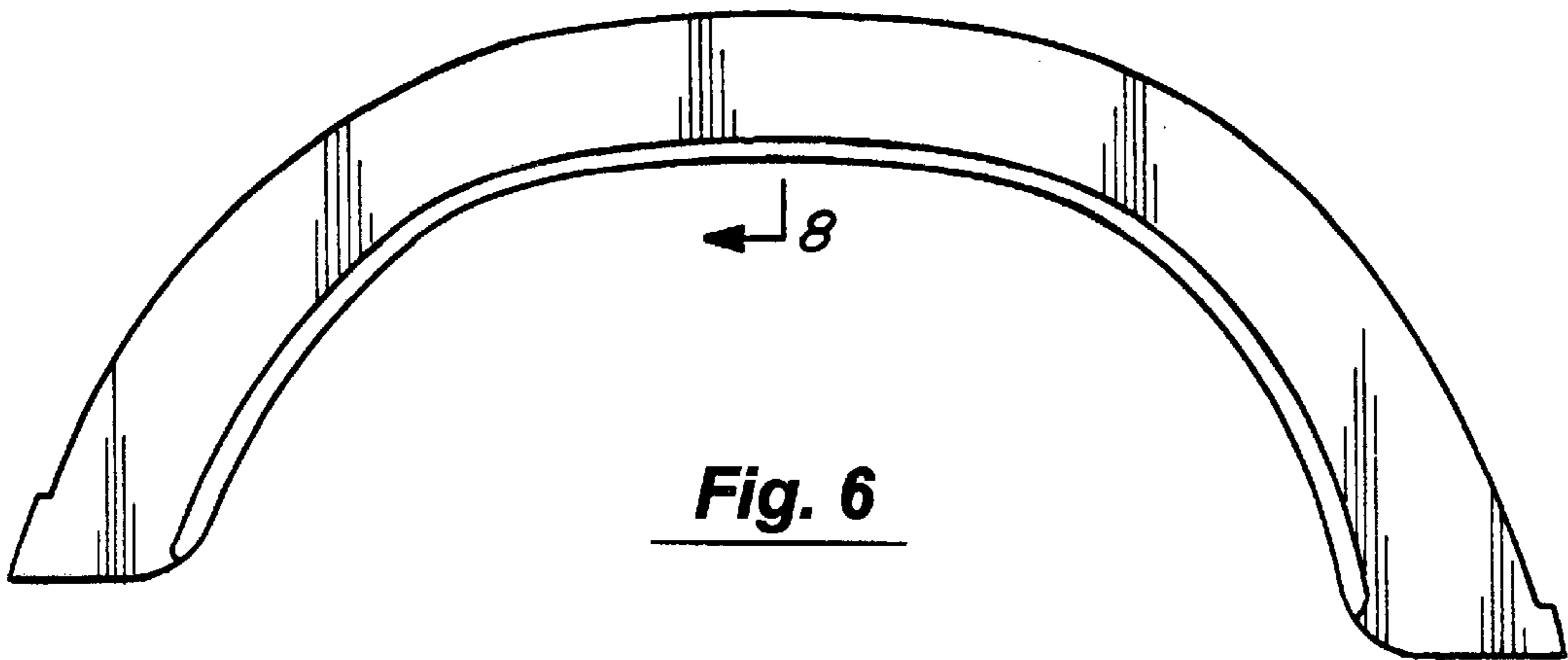

Fig. 8

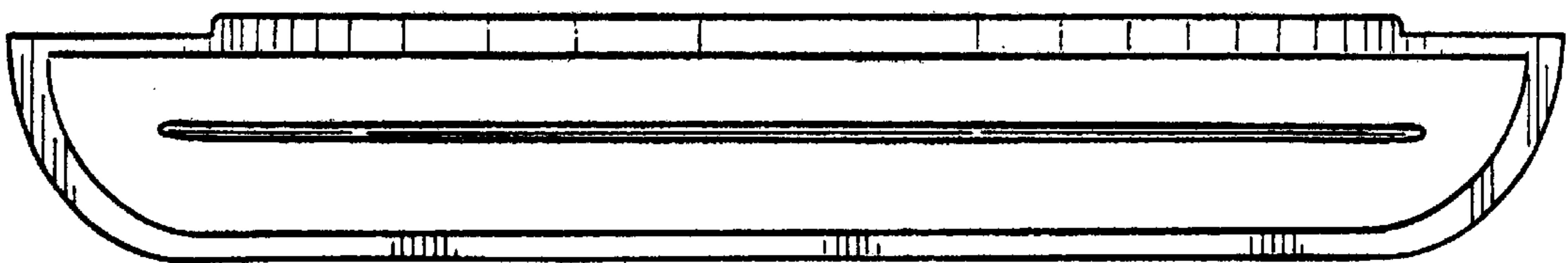

Fig. 7

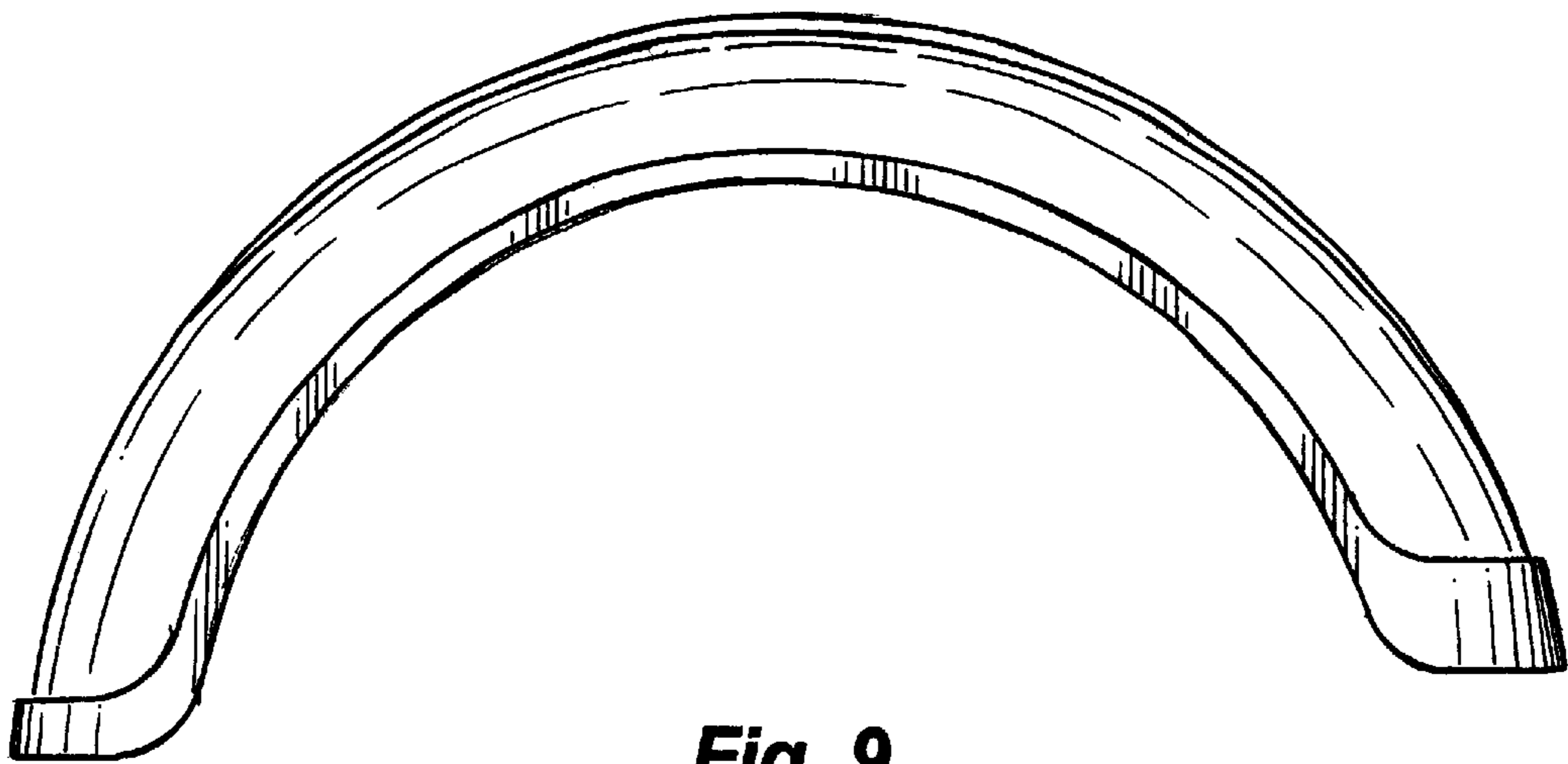

Fig. 9

Fig. 10

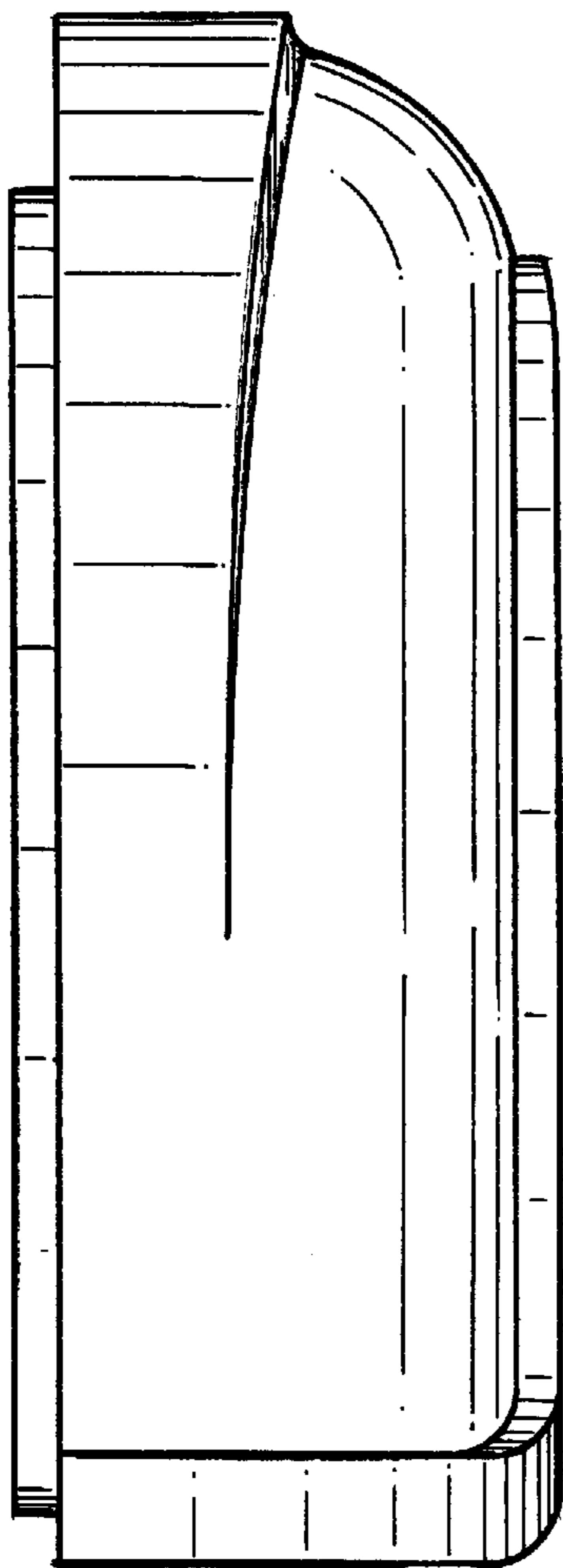

Fig. 11

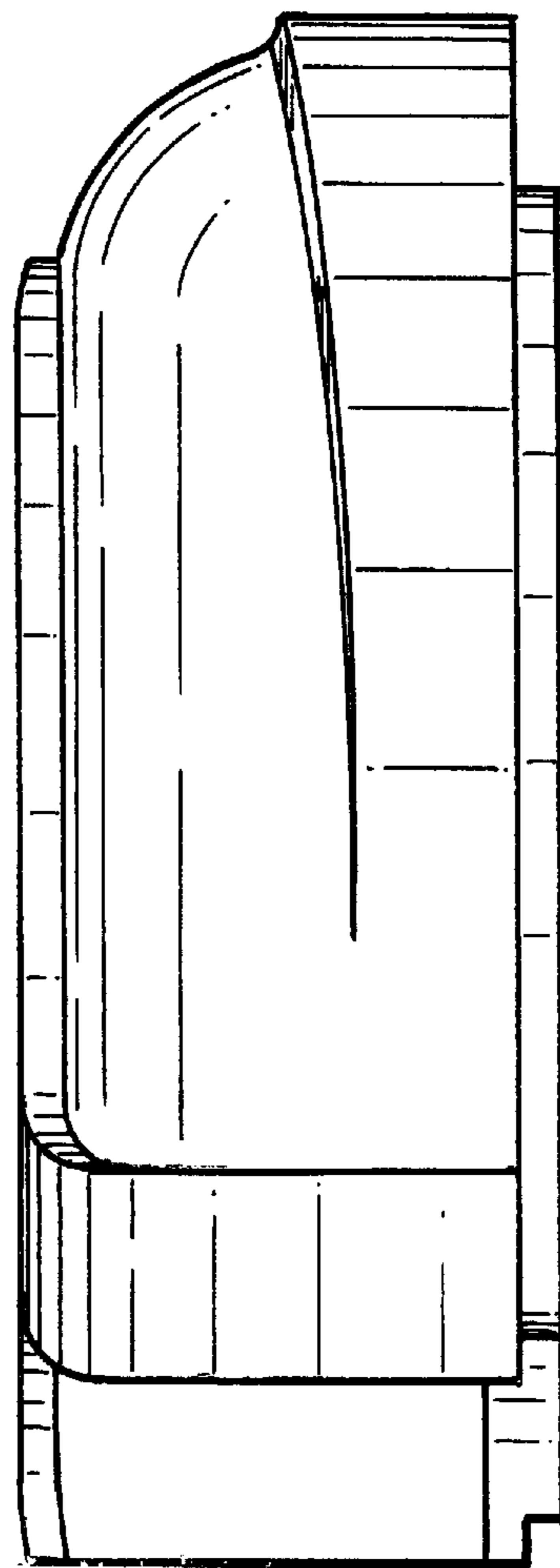

Fig. 12

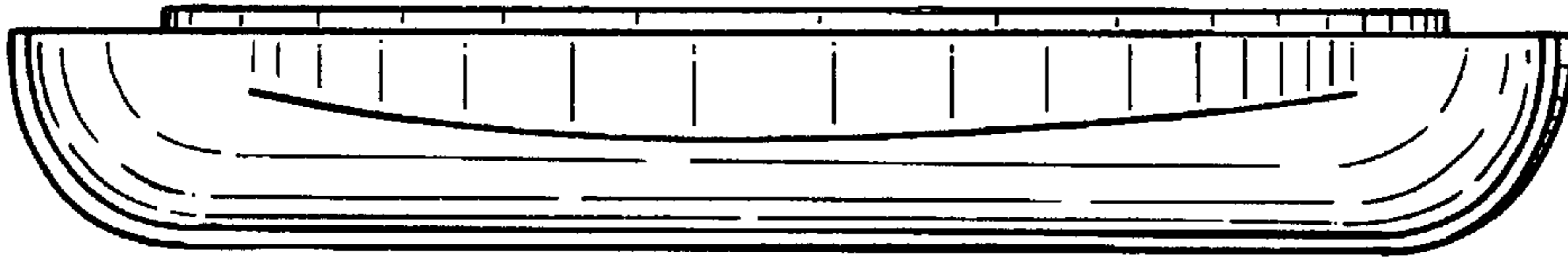

Fig. 13

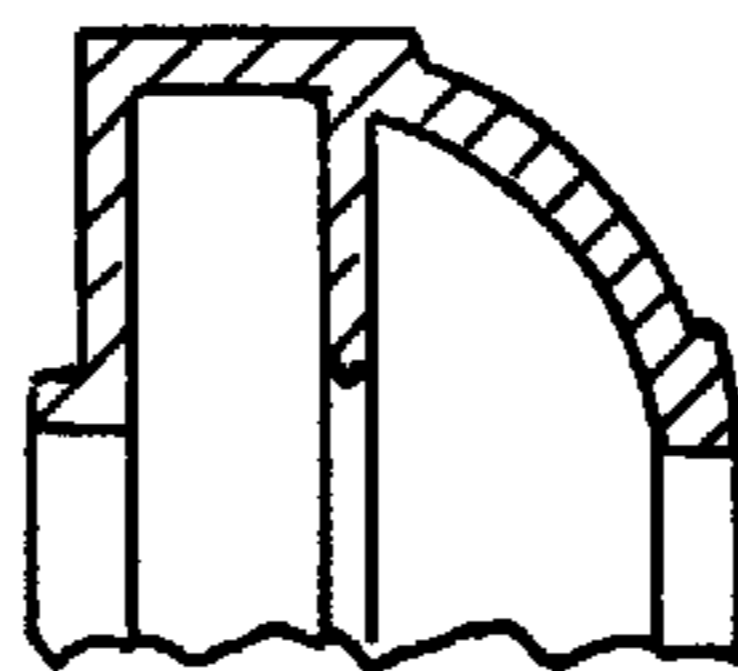
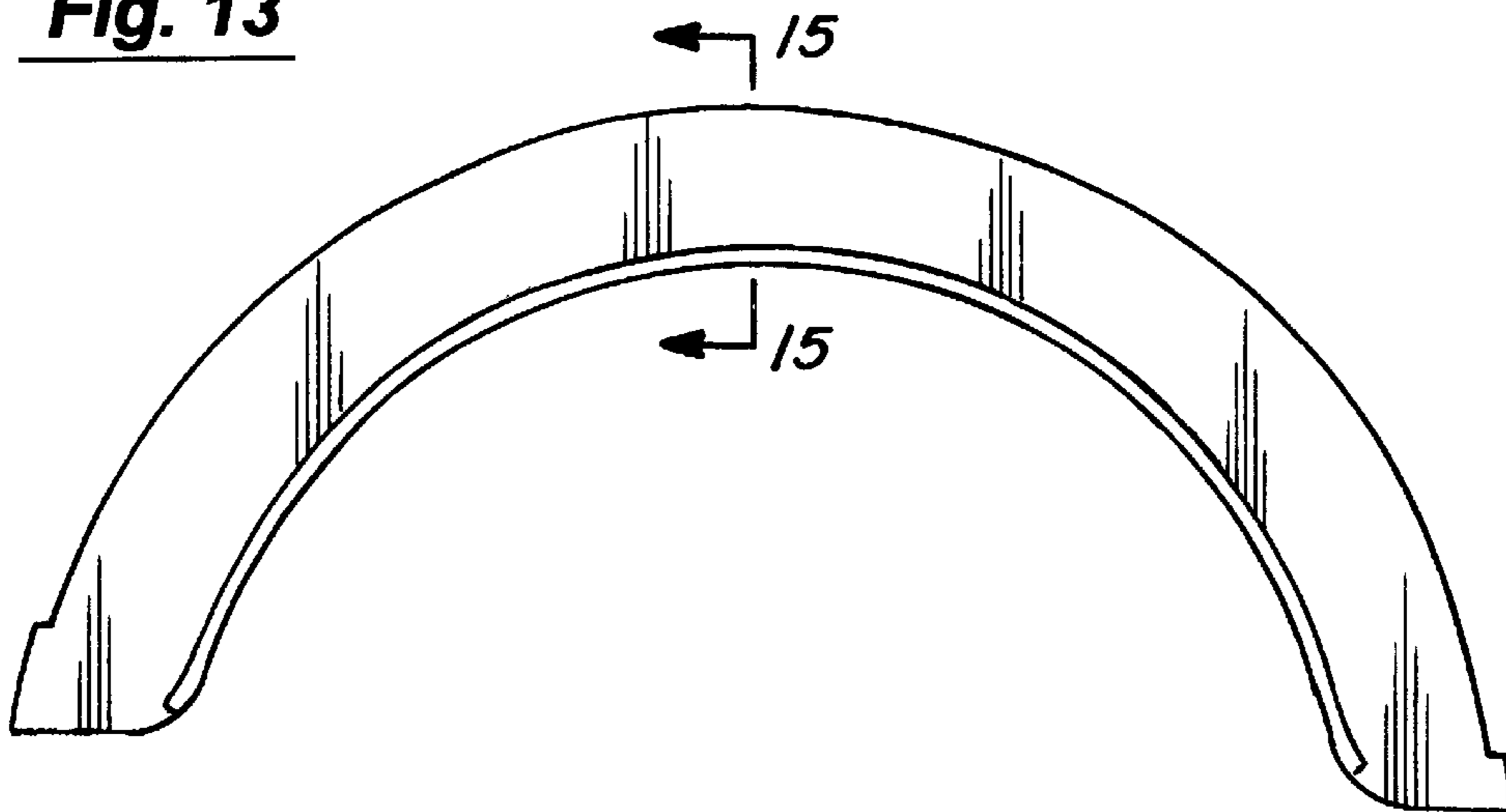

Fig. 15

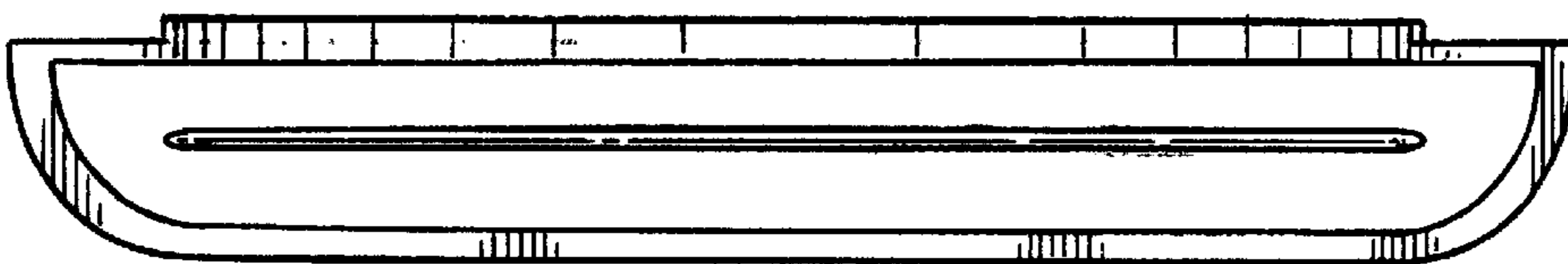

Fig. 14