



US00D461435S

(12) **United States Design Patent**  
**Johnson**

(10) **Patent No.:** **US D461,435 S**

(45) **Date of Patent:** **\*\* Aug. 13, 2002**

(54) **STEERING WHEEL**

(76) Inventor: **James K. Johnson**, 1615 Solano NE.,  
Albuquerque, NM (US) 87110

(\*\*) Term: **14 Years**

(21) Appl. No.: **29/141,368**

(22) Filed: **May 4, 2001**

(51) **LOC (7) Cl.** ..... **12-16**

(52) **U.S. Cl.** ..... **D12/176**

(58) **Field of Search** ..... D12/176, 175,  
D12/177; 174/552, 558

(56) **References Cited**

**U.S. PATENT DOCUMENTS**

D356,765 S	*	3/1995	DiMatteo	.....	D12/176
D367,837 S	*	3/1996	Harding	.....	D12/176
D369,136 S	*	4/1996	Harding	.....	D12/176
D445,740 S	*	7/2001	Hartog	.....	D12/177

**OTHER PUBLICATIONS**

Lecarra Steering Wheels Catalog Speedway Motors Catalog, p.54 publication dates are prior to filing date of application.

\* cited by examiner

*Primary Examiner*—Melody N. Brown

(74) *Attorney, Agent, or Firm*—John R. Lansdowne

(57) **CLAIM**

The ornamental design for a steering wheel as shown and described.

**DESCRIPTION**

FIG. 1 is a perspective view of a steering wheel showing my new design;

FIG. 2 is a front elevation view thereof;

FIG. 3 is a back elevation view thereof;

FIG. 4 is a side elevation view thereof; and,

FIG. 5 is an opposite side elevation view thereof.

The broken lines shown in all drawing views are for illustrative purposes only and form no part of the claimed design.

**1 Claim, 3 Drawing Sheets**

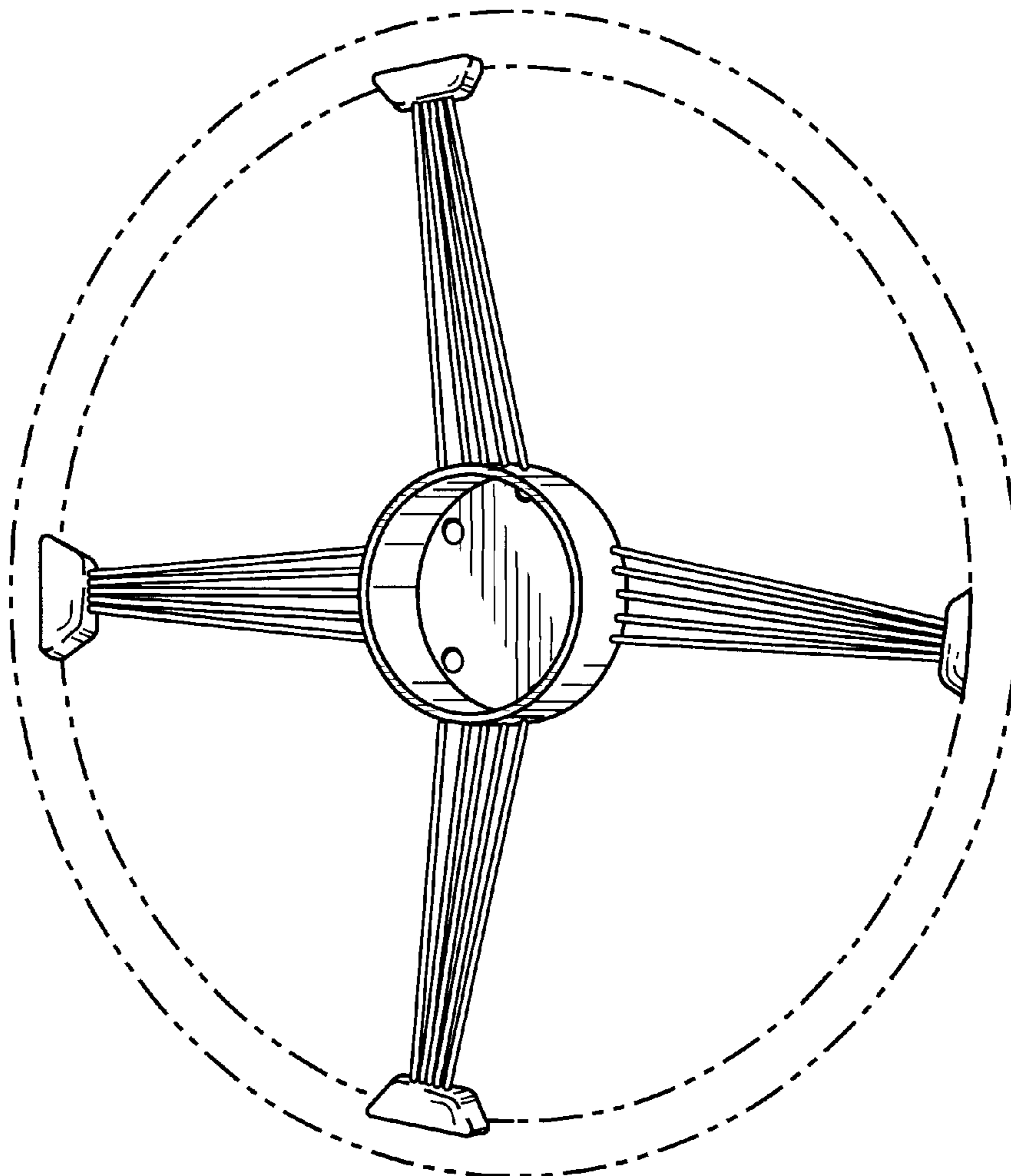

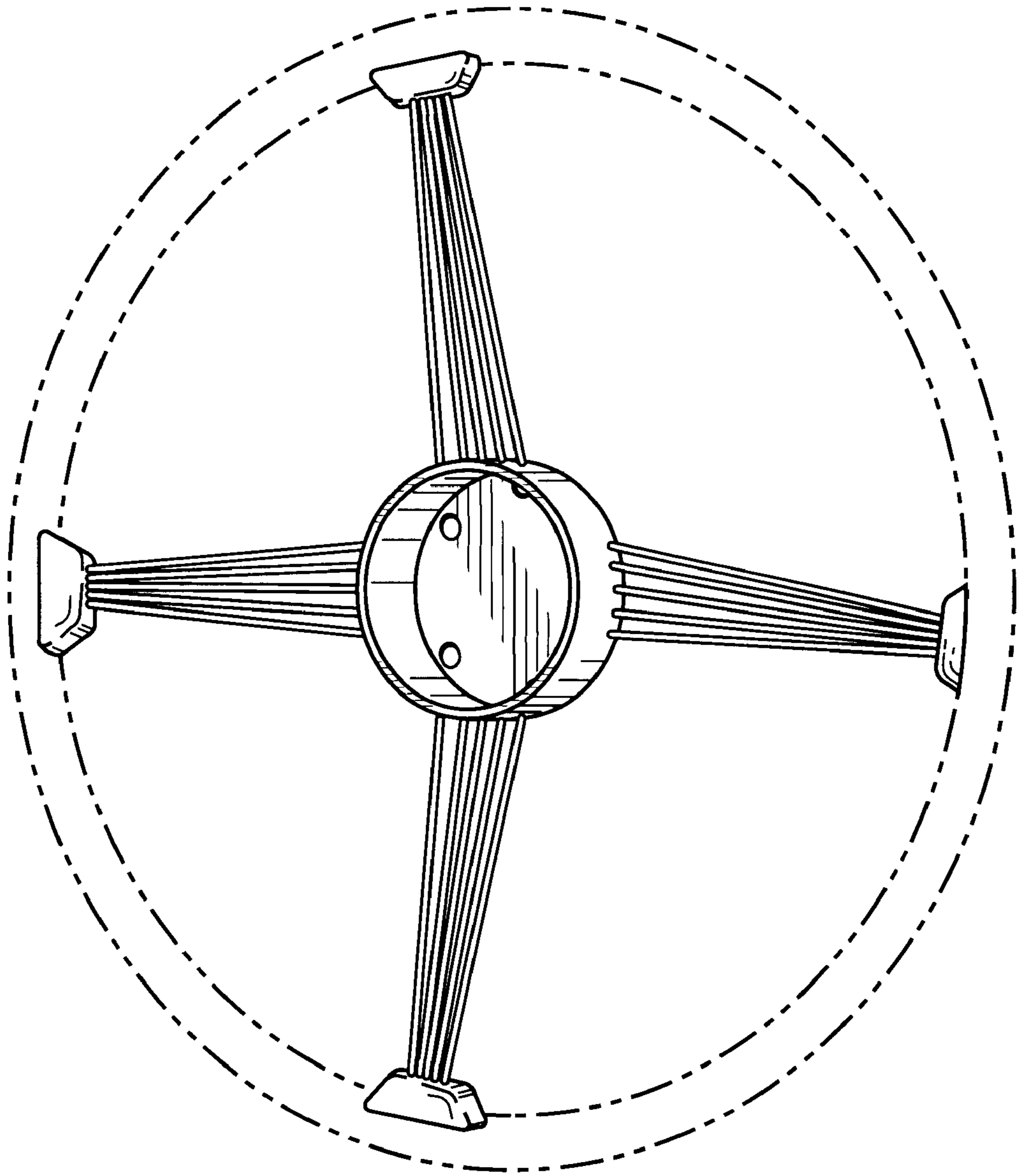

FIG. 1

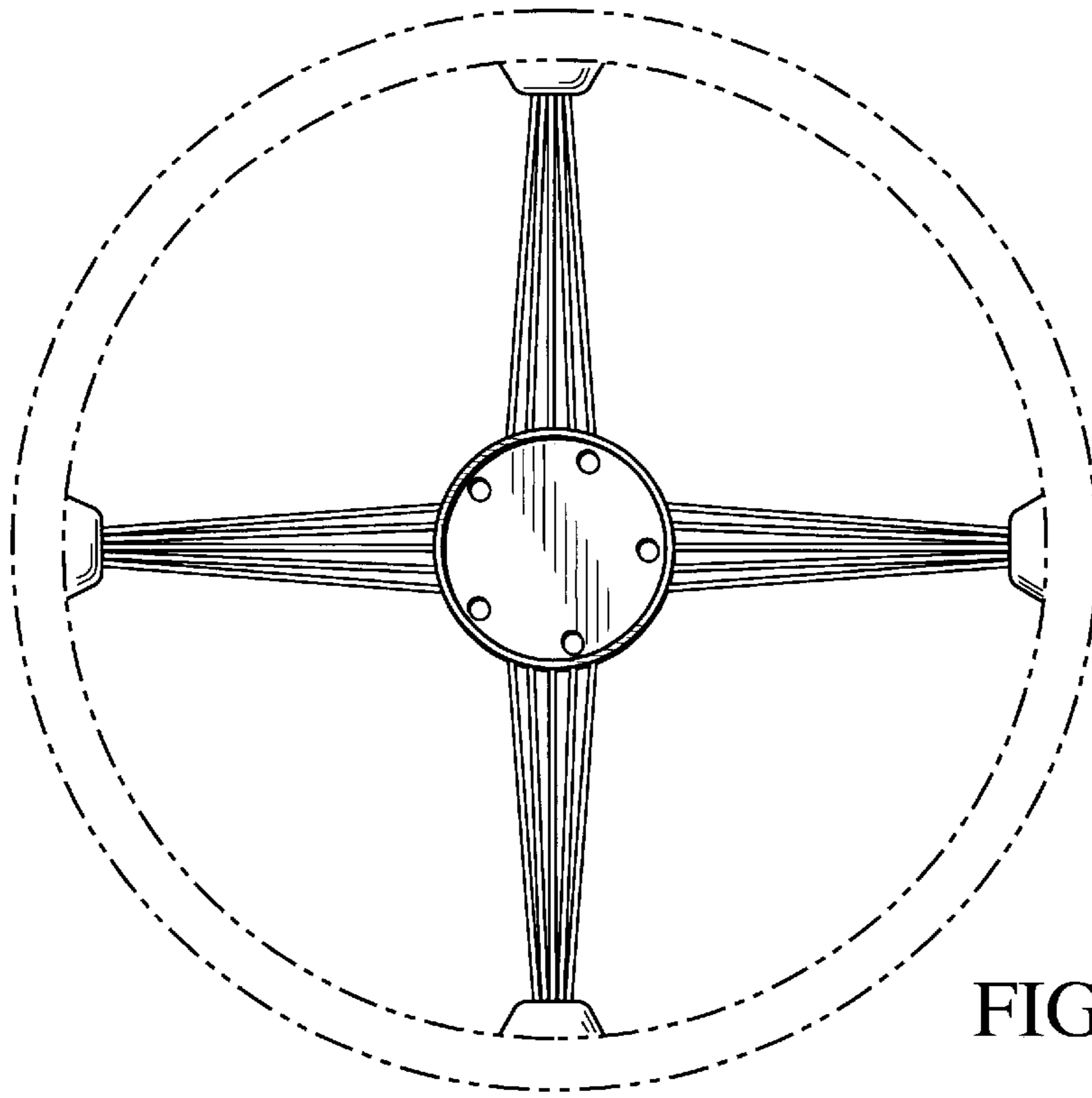

FIG. 2

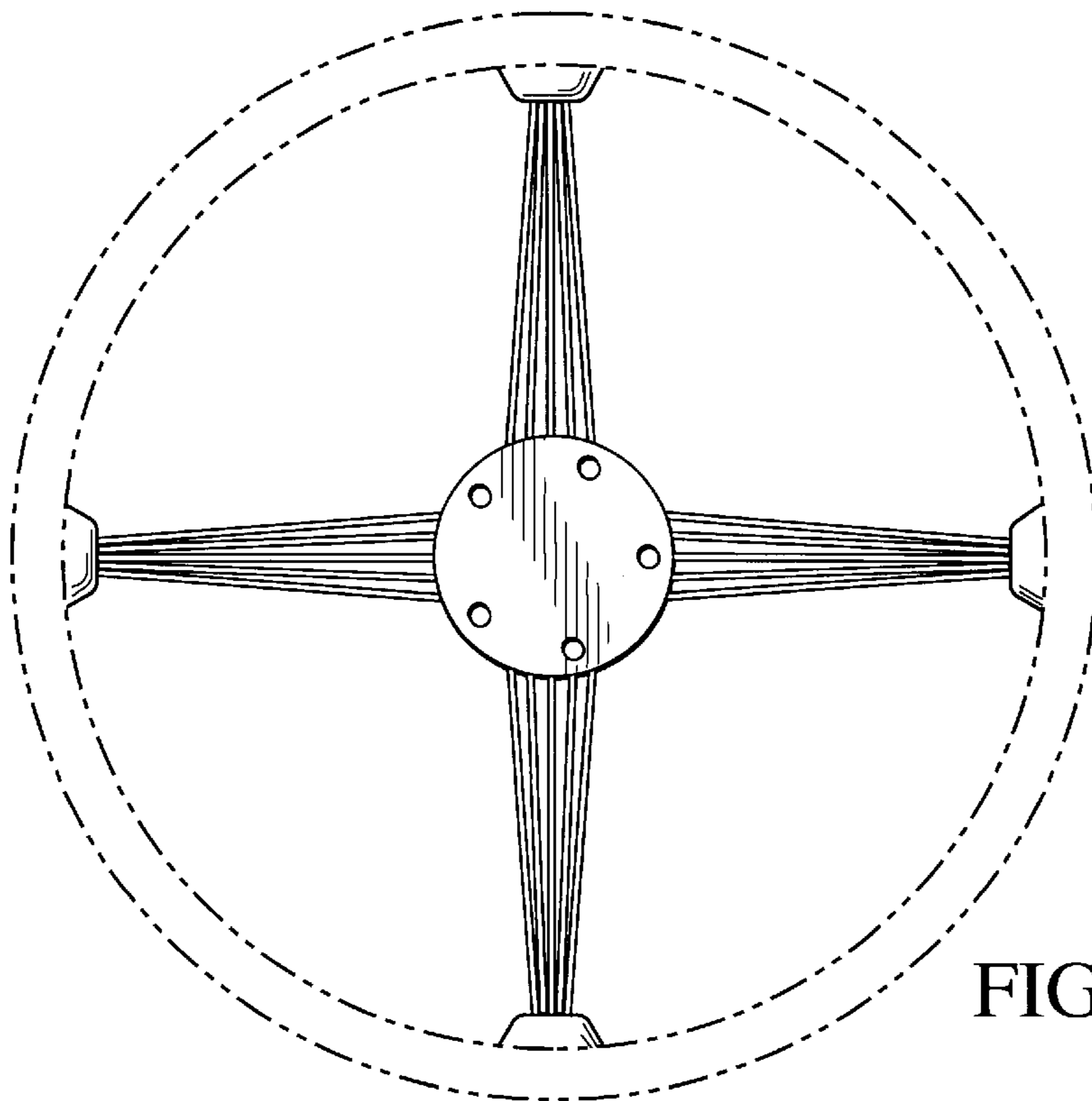

FIG. 3

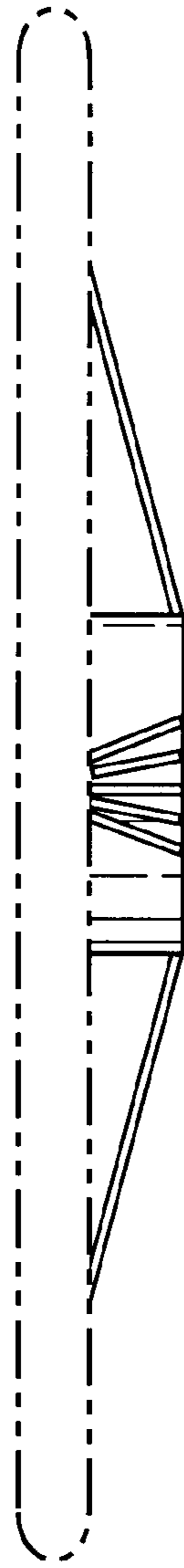

FIG. 4

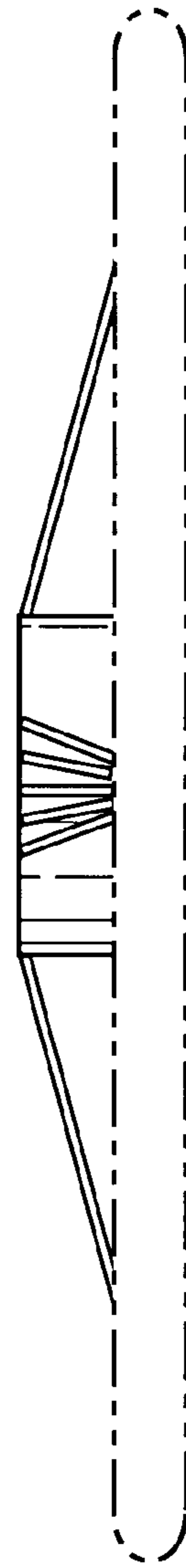

FIG. 5