



US00D461233S

(12) **United States Design Patent**
Whalen

(10) **Patent No.:** **US D461,233 S**

(45) **Date of Patent:** **** Aug. 6, 2002**

(54) **MARINE DECK DRAIN STRAINER**

6,263,518 B1 * 7/2001 Magtanong 4/289

(76) Inventor: **James Michael Whalen**, 3971 Cedar
Island Rd. East, Jacksonville Beach, FL
(US) 32250

* cited by examiner

Primary Examiner—Robin V. Taylor
(74) *Attorney, Agent, or Firm*—Thomas C. Saitta

(**) Term: **14 Years**

(57) **CLAIM**

(21) Appl. No.: **29/150,810**

The ornamental design for a marine deck drain strainer, as shown.

(22) Filed: **Nov. 29, 2001**

(51) **LOC (7) Cl.** **23-01**

(52) **U.S. Cl.** **D23/261**

(58) **Field of Search** D23/260–262;
4/286, 287, 291, 292, 498; 210/163–4

DESCRIPTION

The invention was not made by an agency of the U.S. Government or under a contract with an agency of the U.S. Government.

FIG. 1 is a top view of the invention.

FIG. 2 is a bottom view.

FIG. 3 is a left side view.

FIG. 4 is a right side view.

FIG. 5 is a back view; and,

FIG. 6 is a front view.

(56) **References Cited**

U.S. PATENT DOCUMENTS

3,212,416 A * 10/1965 Boersma 4/292
4,655,913 A * 4/1987 Boersma 210/163
D290,166 S * 6/1987 Jacuzzi D23/261
5,575,903 A * 11/1996 Kato 210/164

1 Claim, 2 Drawing Sheets

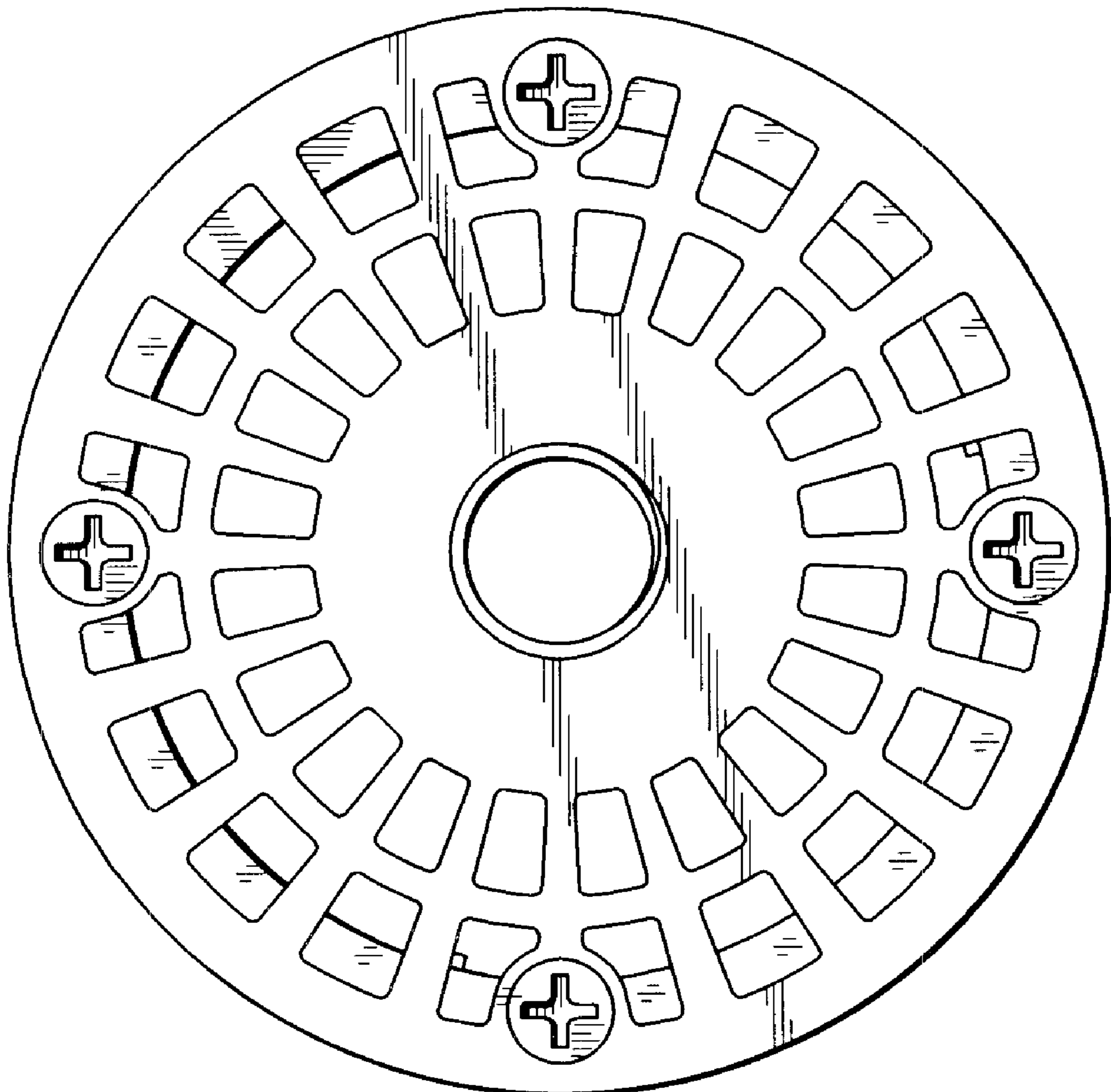

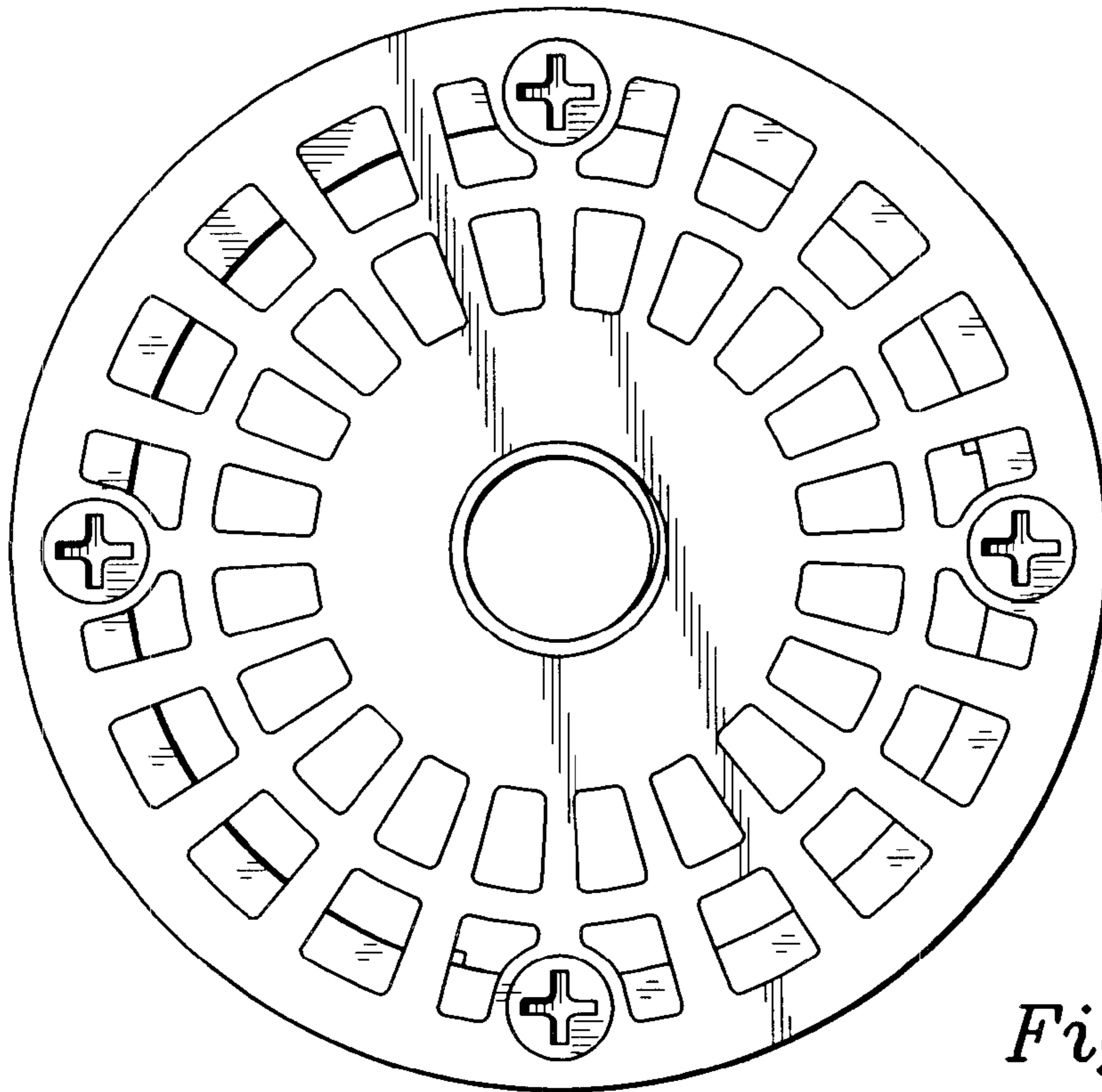

Fig. 1

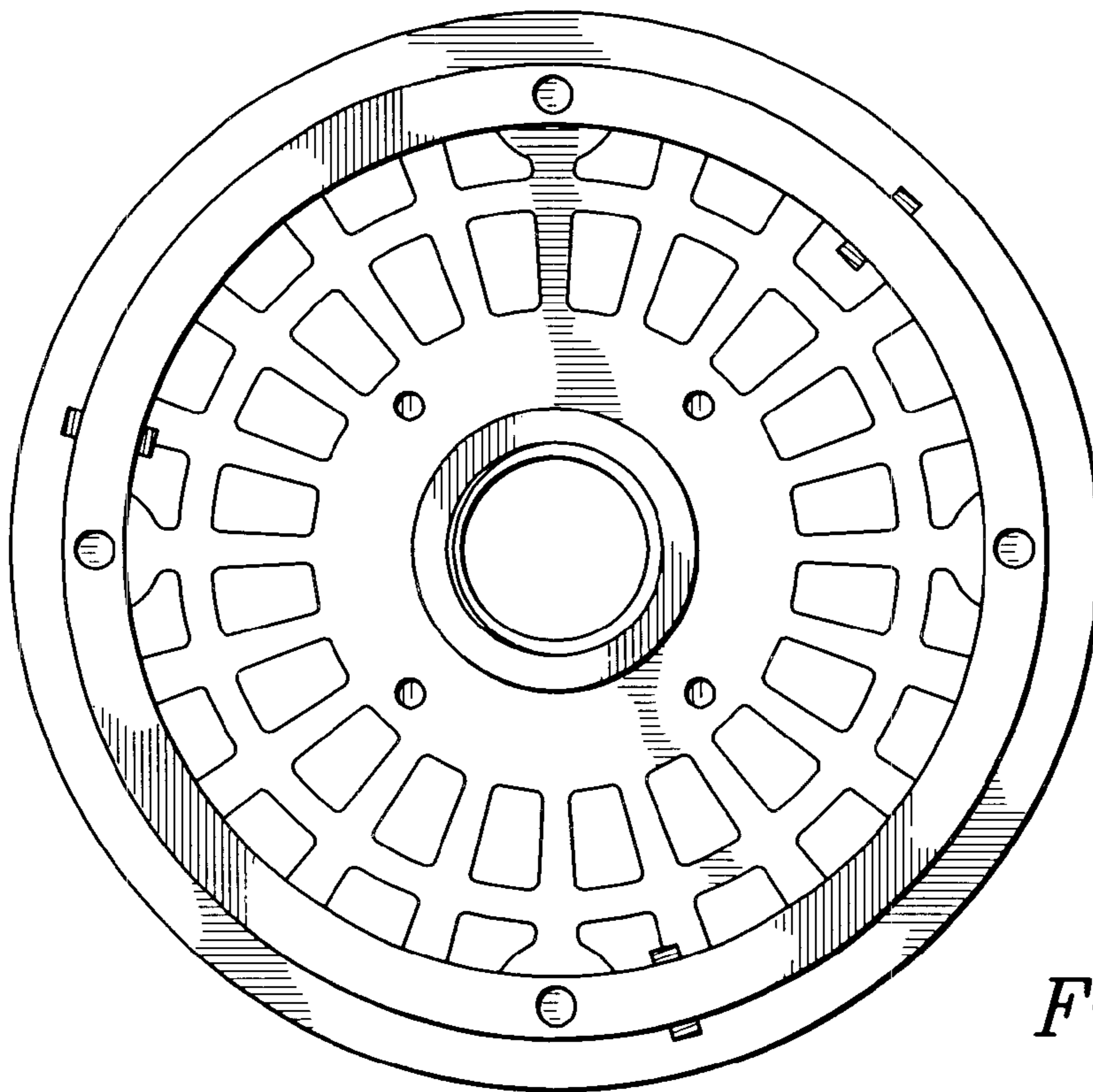

Fig. 2

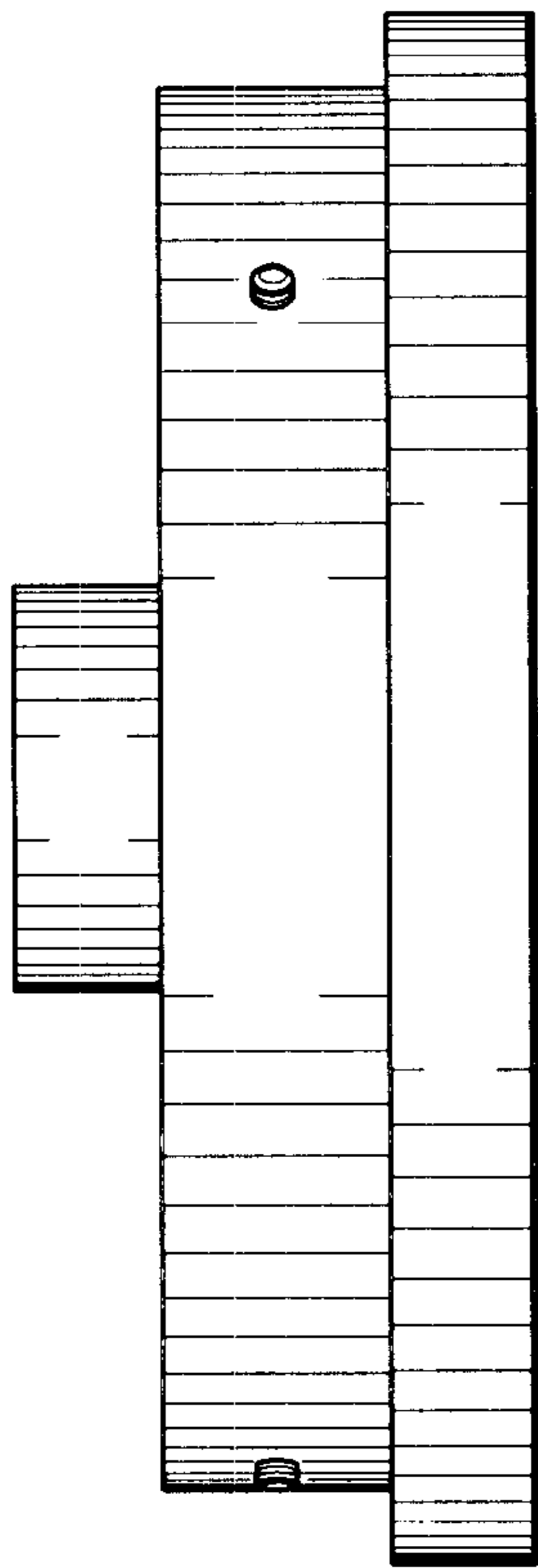

Fig. 3

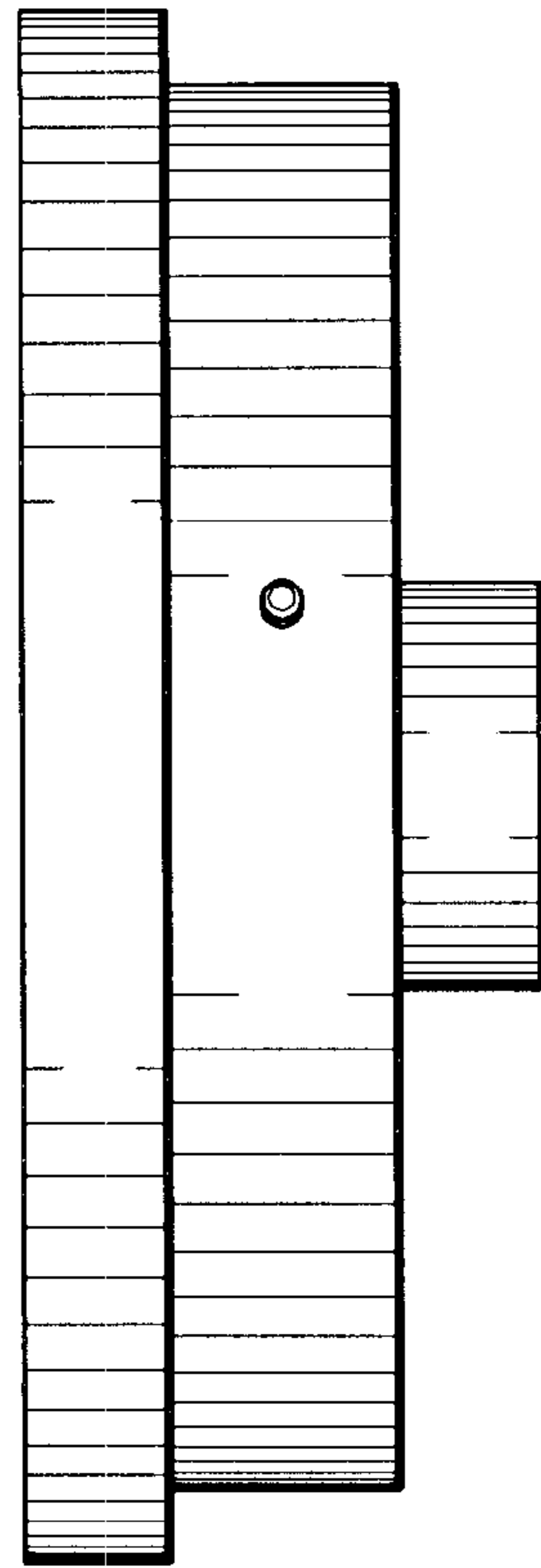

Fig. 4

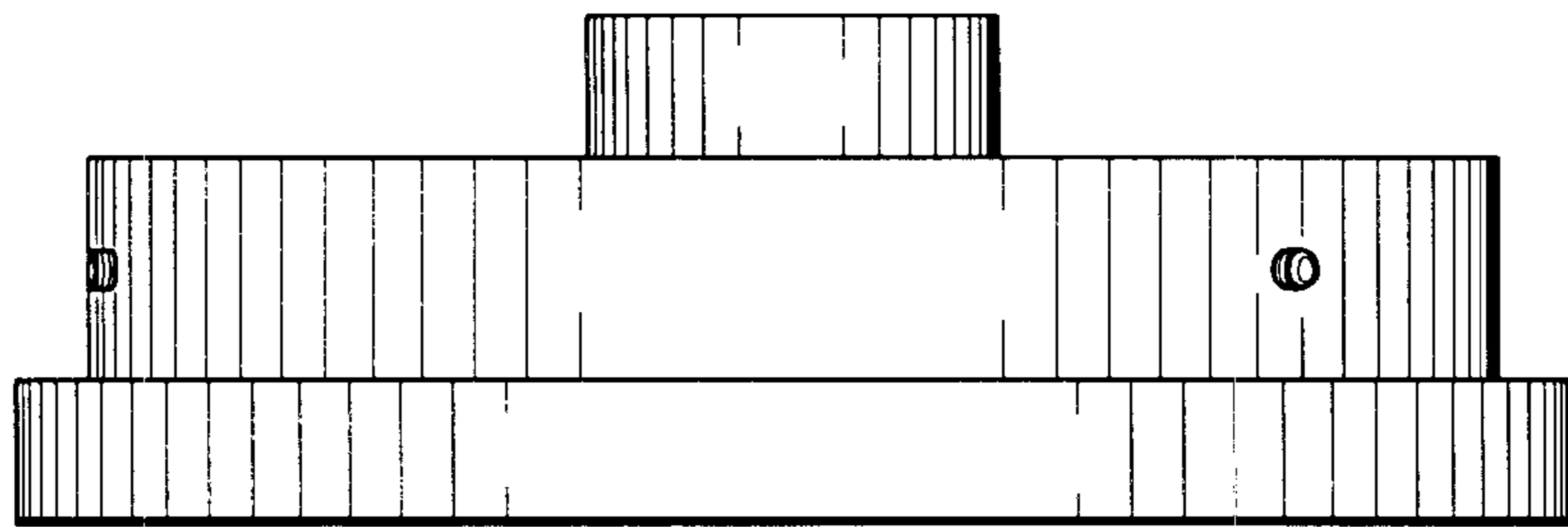

Fig. 5

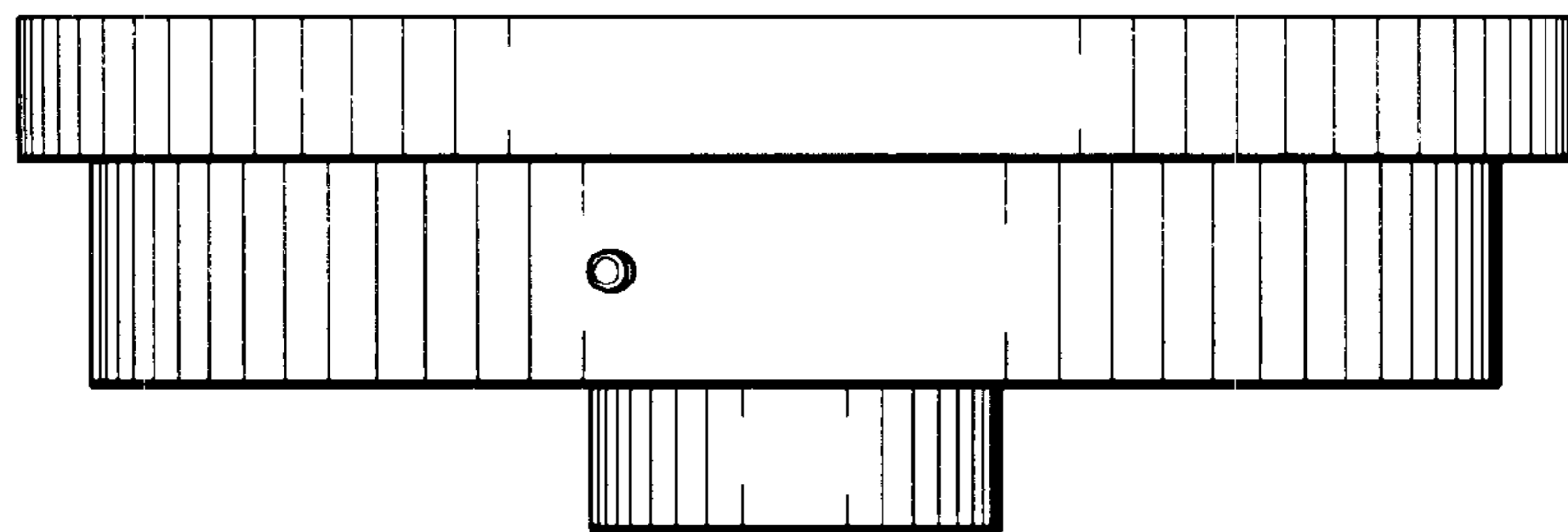

Fig. 6