



US00D461161S

(12) **United States Design Patent**
Hoy

(10) **Patent No.:** **US D461,161 S**

(45) **Date of Patent:** **** Aug. 6, 2002**

(54) **VEHICLE CONSOLE**

(75) Inventor: **John W. Hoy**, Olpe, KS (US)

(73) Assignee: **Hopkins Manufacturing Corporation**,
Emporia, KS (US)

(**) Term: **14 Years**

(21) Appl. No.: **29/154,564**

(22) Filed: **Jan. 24, 2002**

(51) **LOC (7) Cl.** **12-16**

(52) **U.S. Cl.** **D12/419**

(58) **Field of Search** D12/415, 419-425;
224/42.11, 439-543, 400, 926, 536, 928,
548, 275; 296/37.1-37.8, 37.12, 37.16

(56) **References Cited**

U.S. PATENT DOCUMENTS

| | | | | |
|------------|---|---------|-----------------------|---------|
| D302,356 S | * | 7/1989 | Bell et al. | D12/419 |
| D352,495 S | * | 11/1994 | Mawhinney et al. | D12/419 |
| D375,480 S | * | 11/1996 | Smith | D12/419 |
| D375,719 S | * | 11/1996 | Schlangen et al. | D12/419 |
| D390,186 S | * | 2/1998 | Smith | D12/419 |
| D396,844 S | * | 8/1998 | Smith | D12/419 |
| D444,120 S | * | 6/2001 | Smith | D12/419 |

* cited by examiner

Primary Examiner—Stacia Cadmus

(74) *Attorney, Agent, or Firm*—Hovey Williams LLP

(57) **CLAIM**

The ornamental design for a vehicle console, as shown and described.

DESCRIPTION

FIG. 1 is an isometric view of a first embodiment of the console shown with its lids opened;

FIG. 2 is an isometric view of the console of FIG. 1 shown with its lids closed;

FIG. 3 is a top view of the console of FIG. 1 shown with the lids removed;

FIG. 4 is a left side elevational view of the console of FIG. 1 shown with the lid removed;

FIG. 5 is a right side elevational view of the console of FIG. 1 shown with the lid removed;

FIG. 6 is a front elevational view of the console of FIG. 1 shown with the lids removed;

FIG. 7 is a rear elevational view of the console of FIG. 1 shown with the lids removed;

FIG. 8 is an isometric view of a second embodiment of the console shown with its lids opened;

FIG. 9 is an isometric view of the console of FIG. 8 shown with its lids closed;

FIG. 10 is a top view of the console of FIG. 8 shown with the lids removed;

FIG. 11 is a left side elevational view of console of FIG. 8 shown with the lid removed;

FIG. 12 is a right side elevational view of a second embodiment of the console shown with the lid removed;

FIG. 13 is a front elevational view of the console of FIG. 8 shown with the lids removed; and,

FIG. 14 is a rear elevational view of the console of FIG. 8 shown with the lids removed.

1 Claim, 6 Drawing Sheets

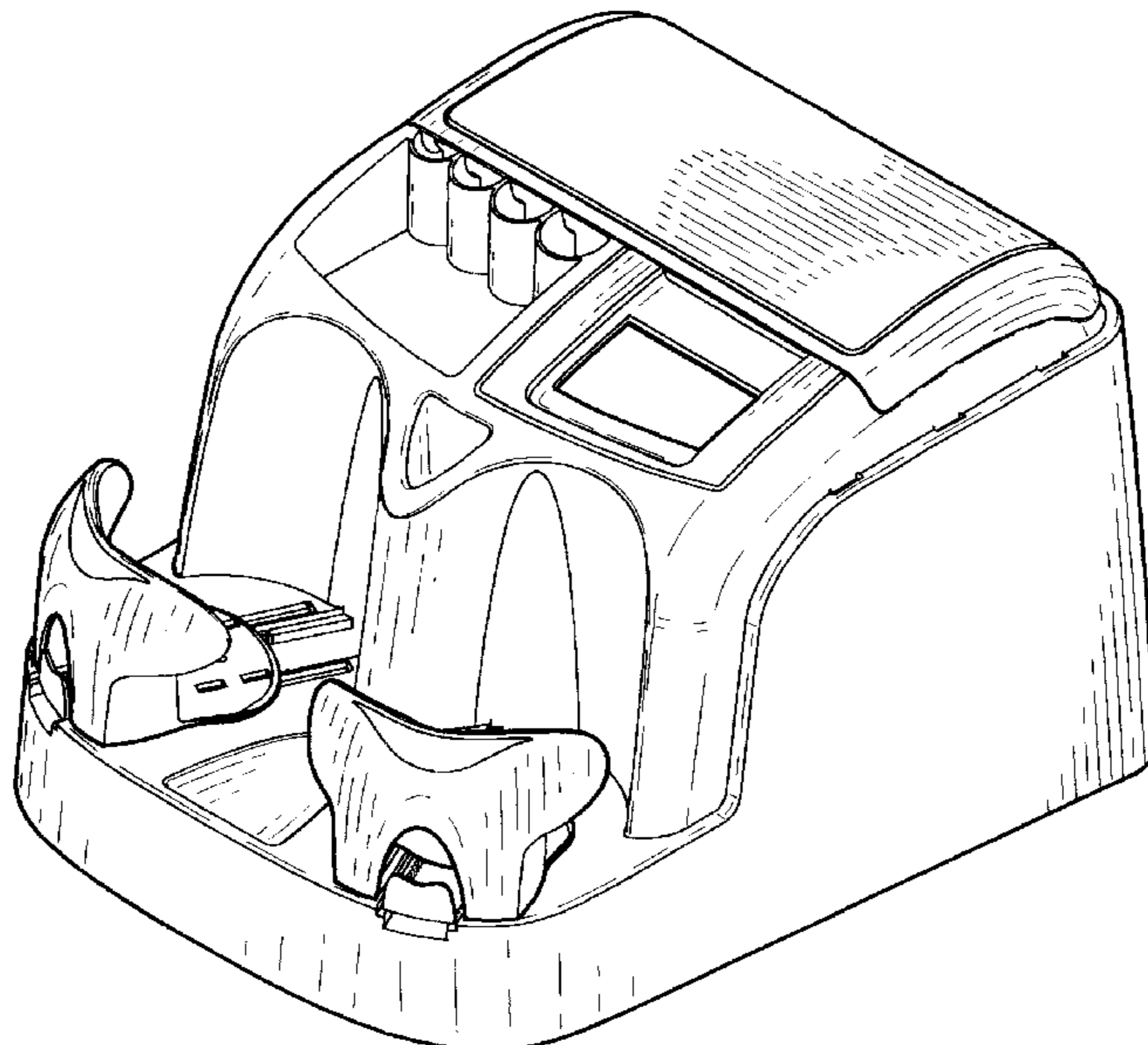

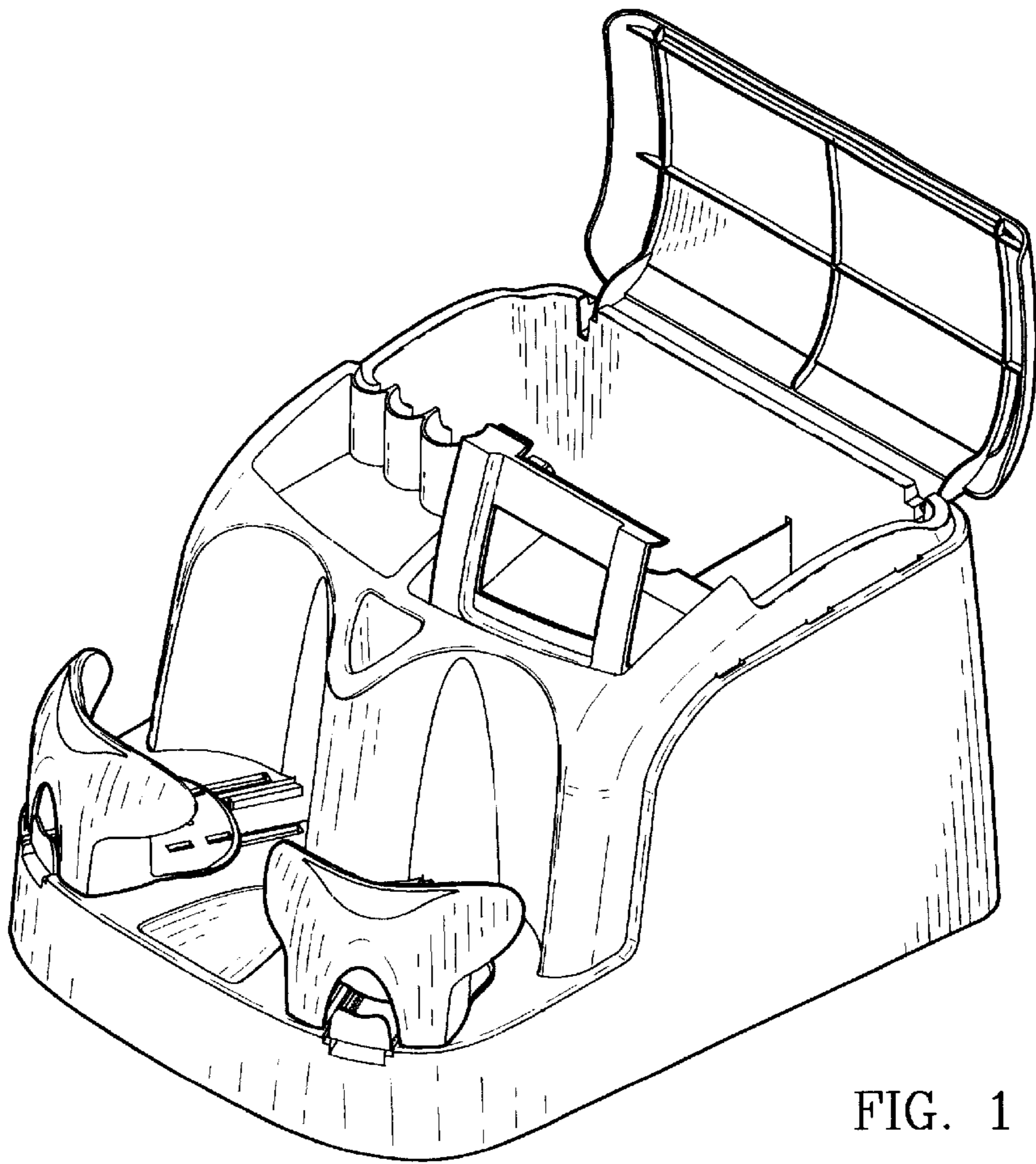

FIG. 1

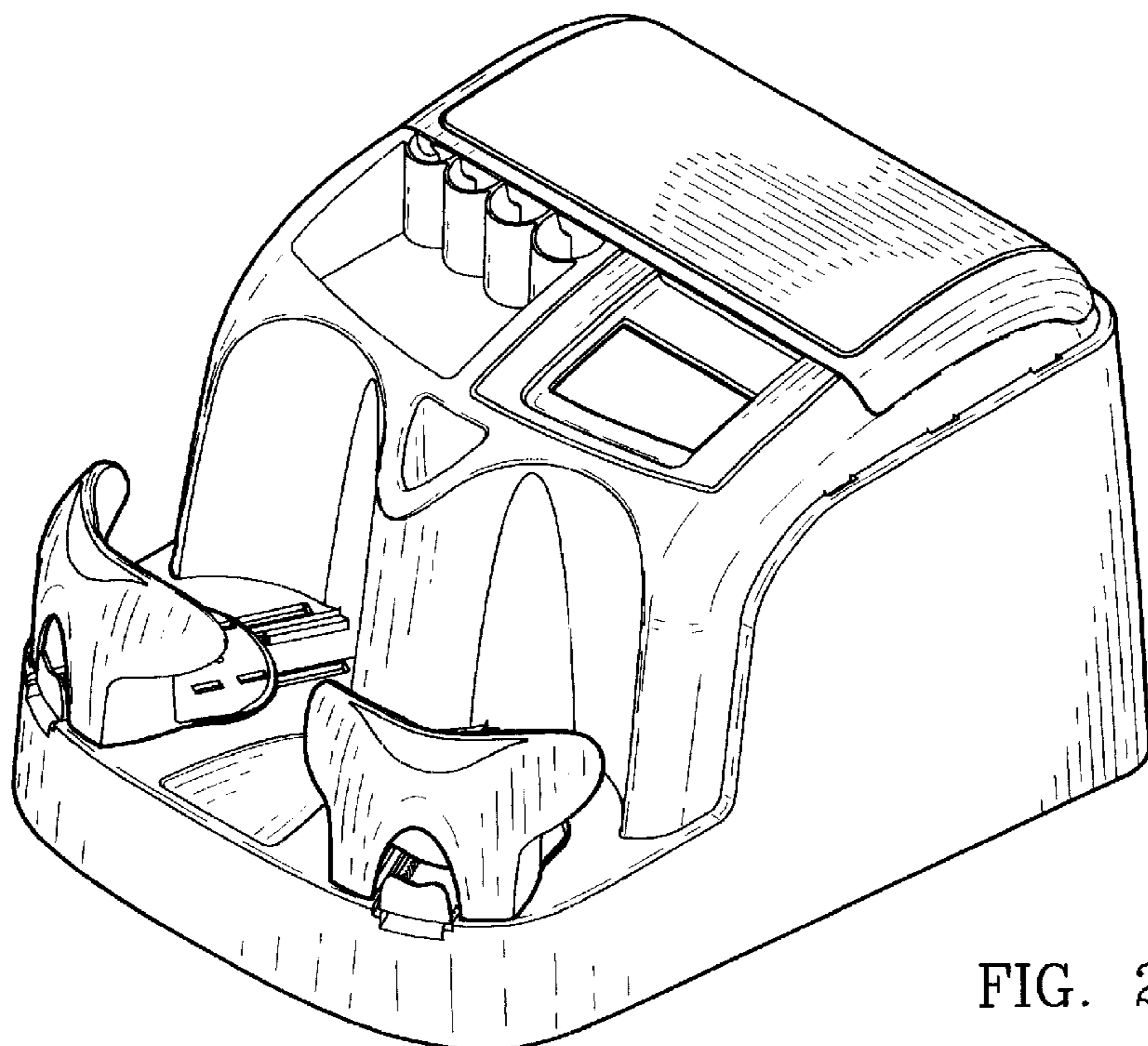

FIG. 2

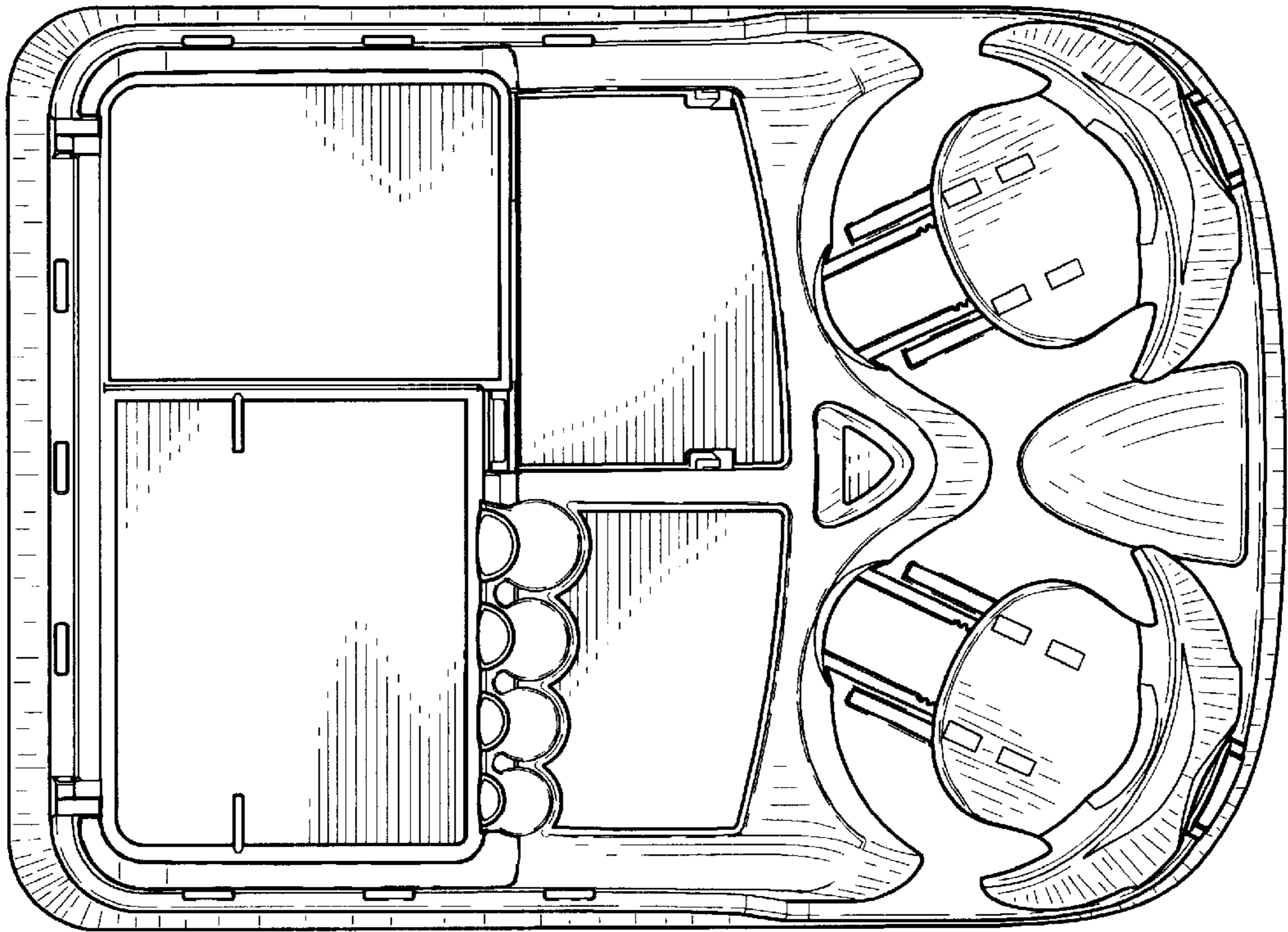

FIG. 3

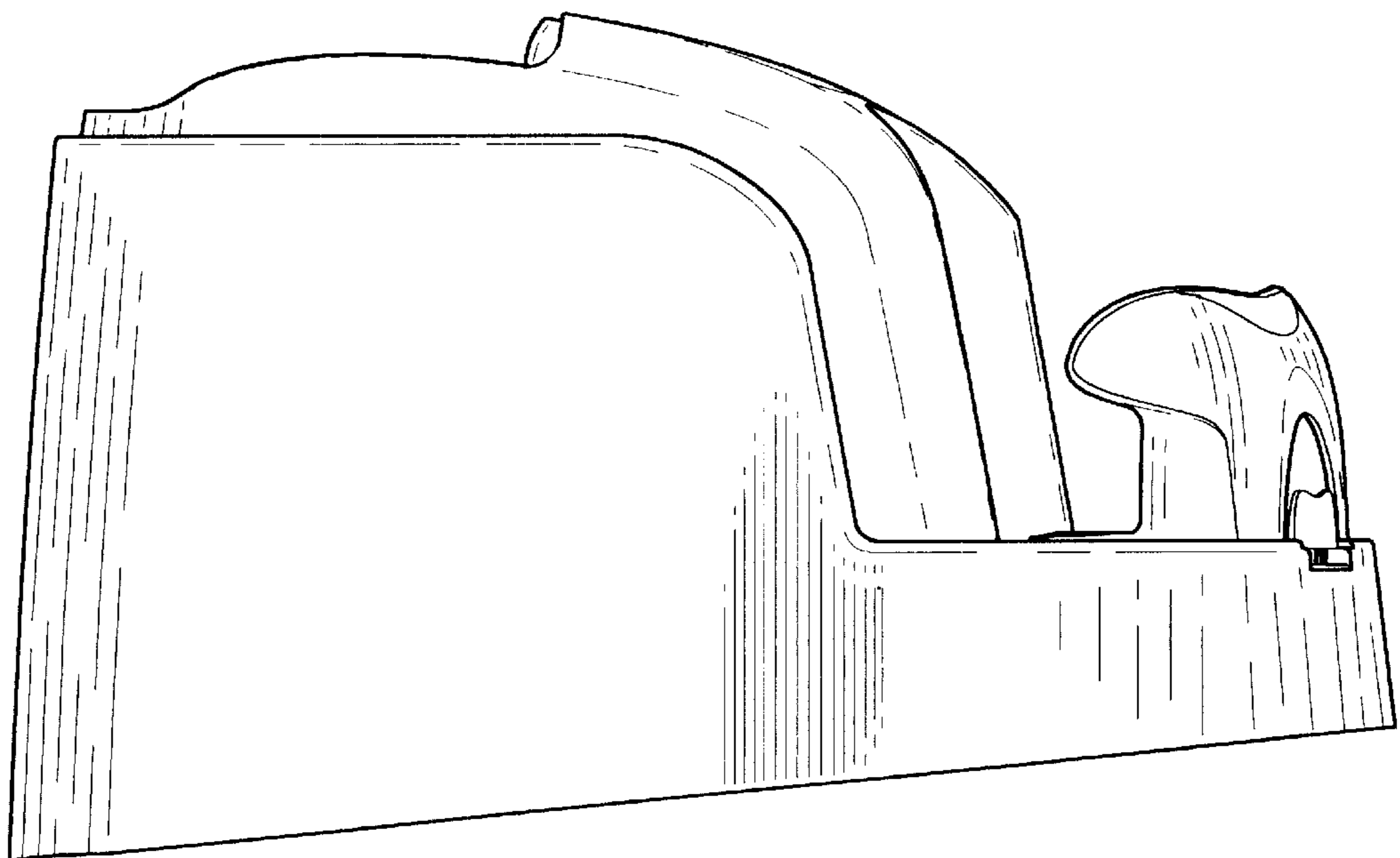

FIG. 4

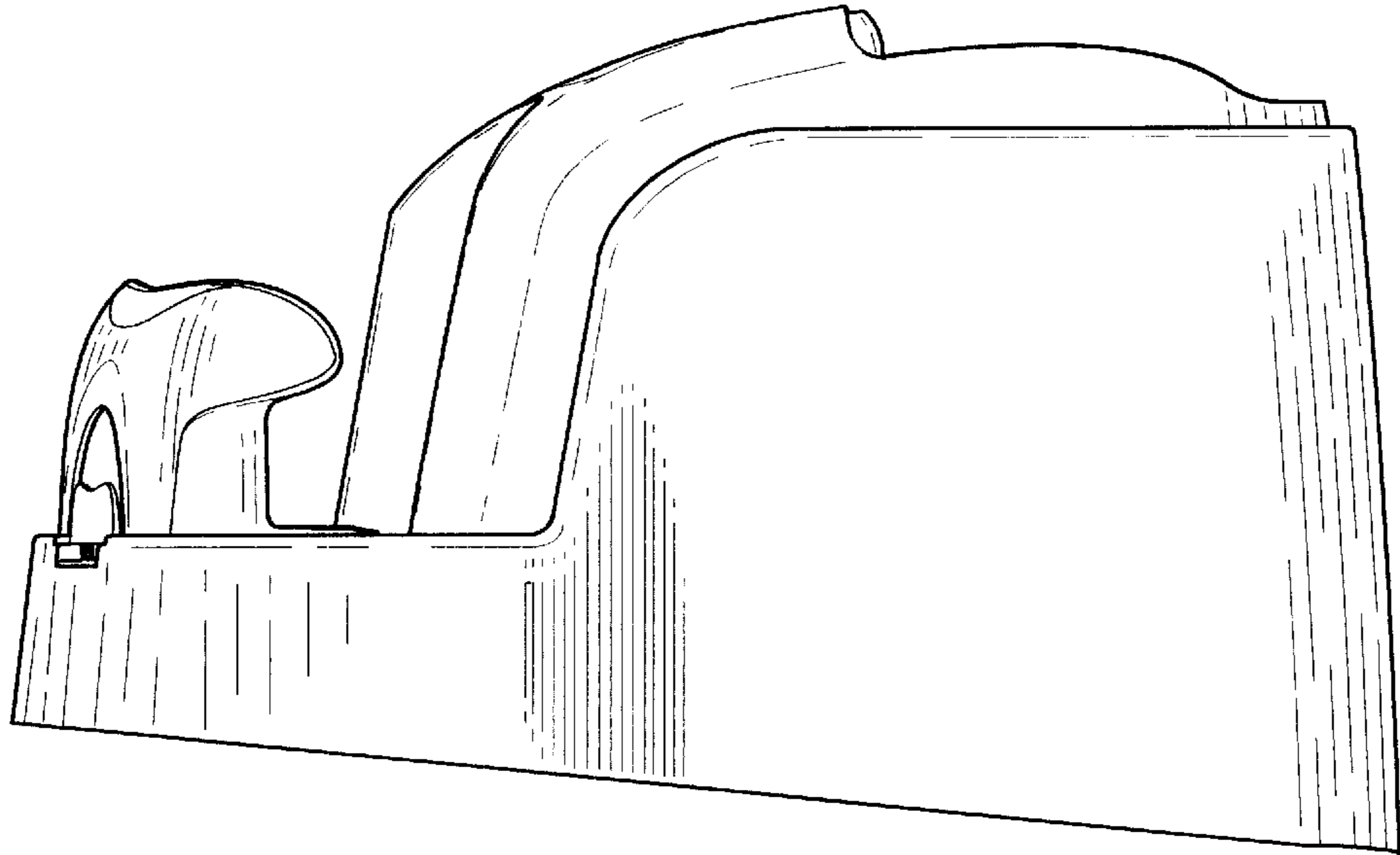

FIG. 5

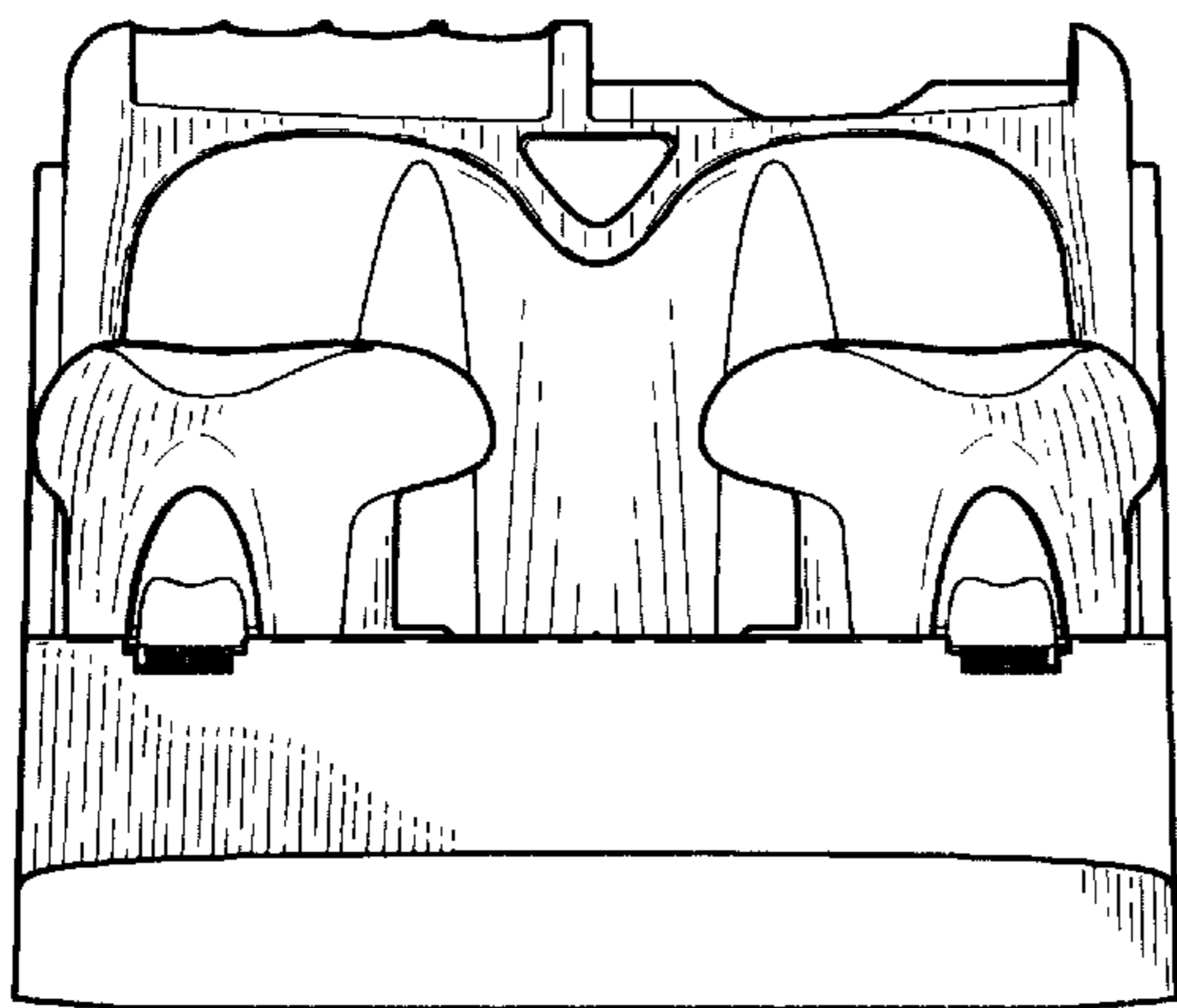

FIG. 6

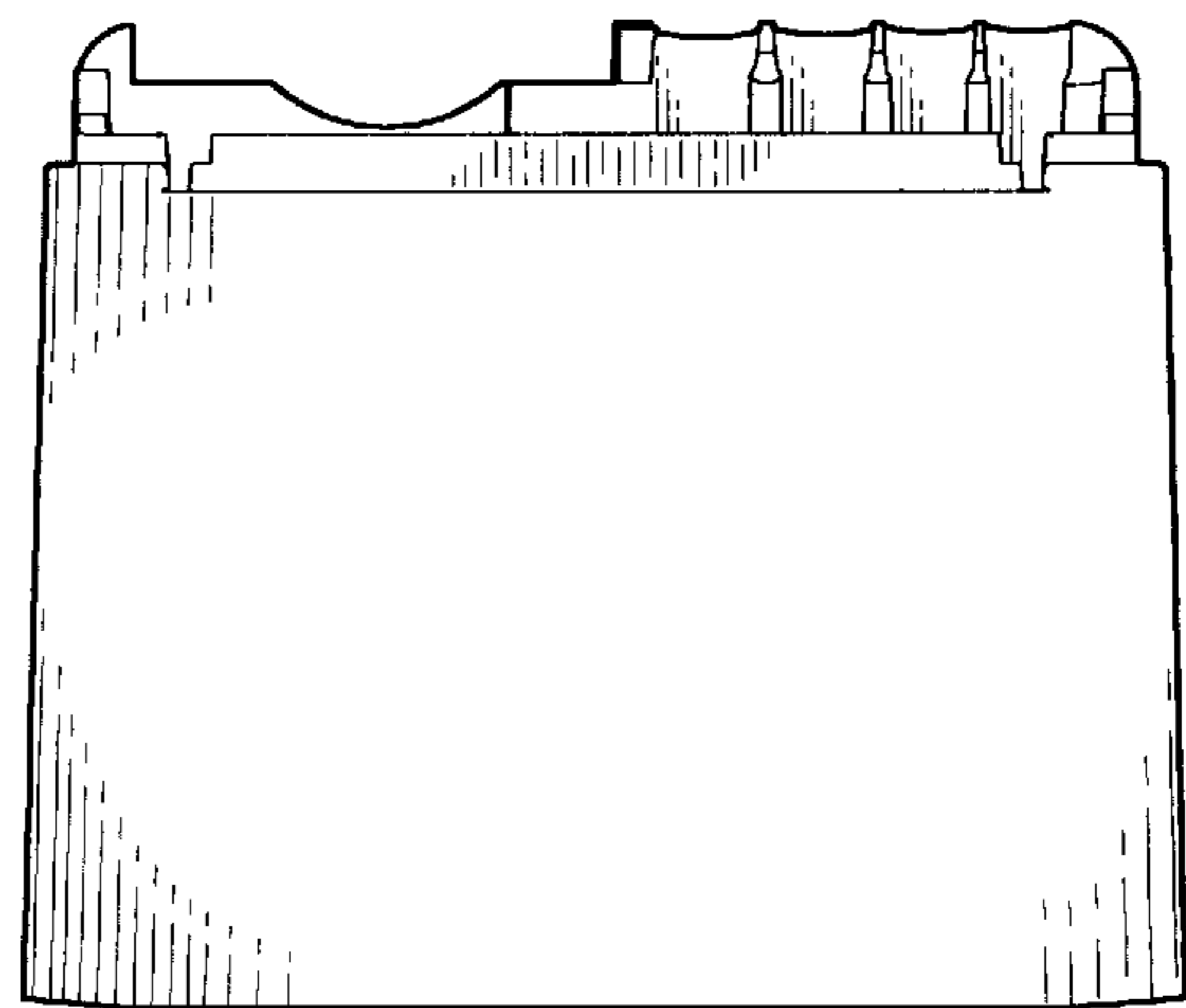

FIG. 7

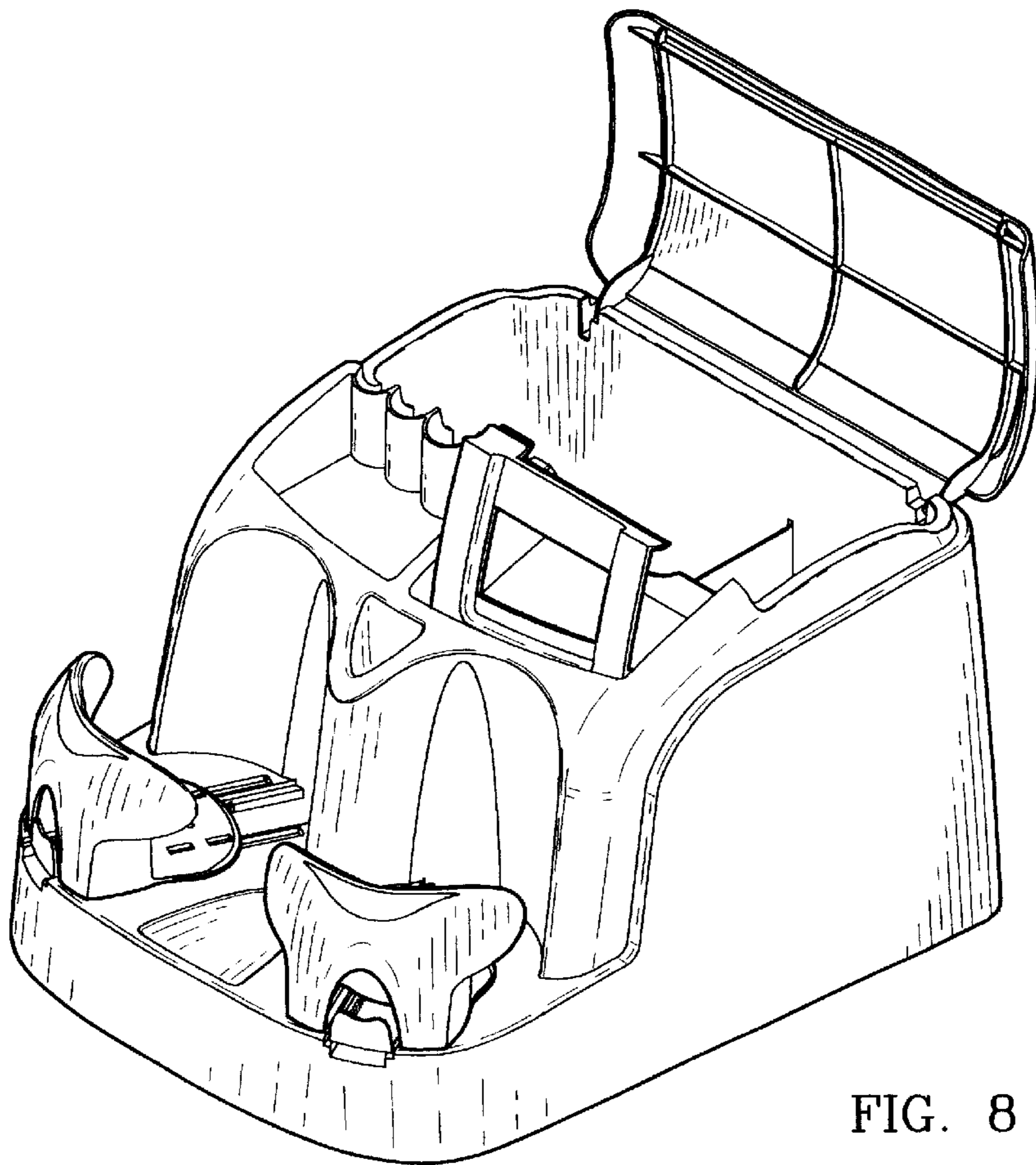

FIG. 8

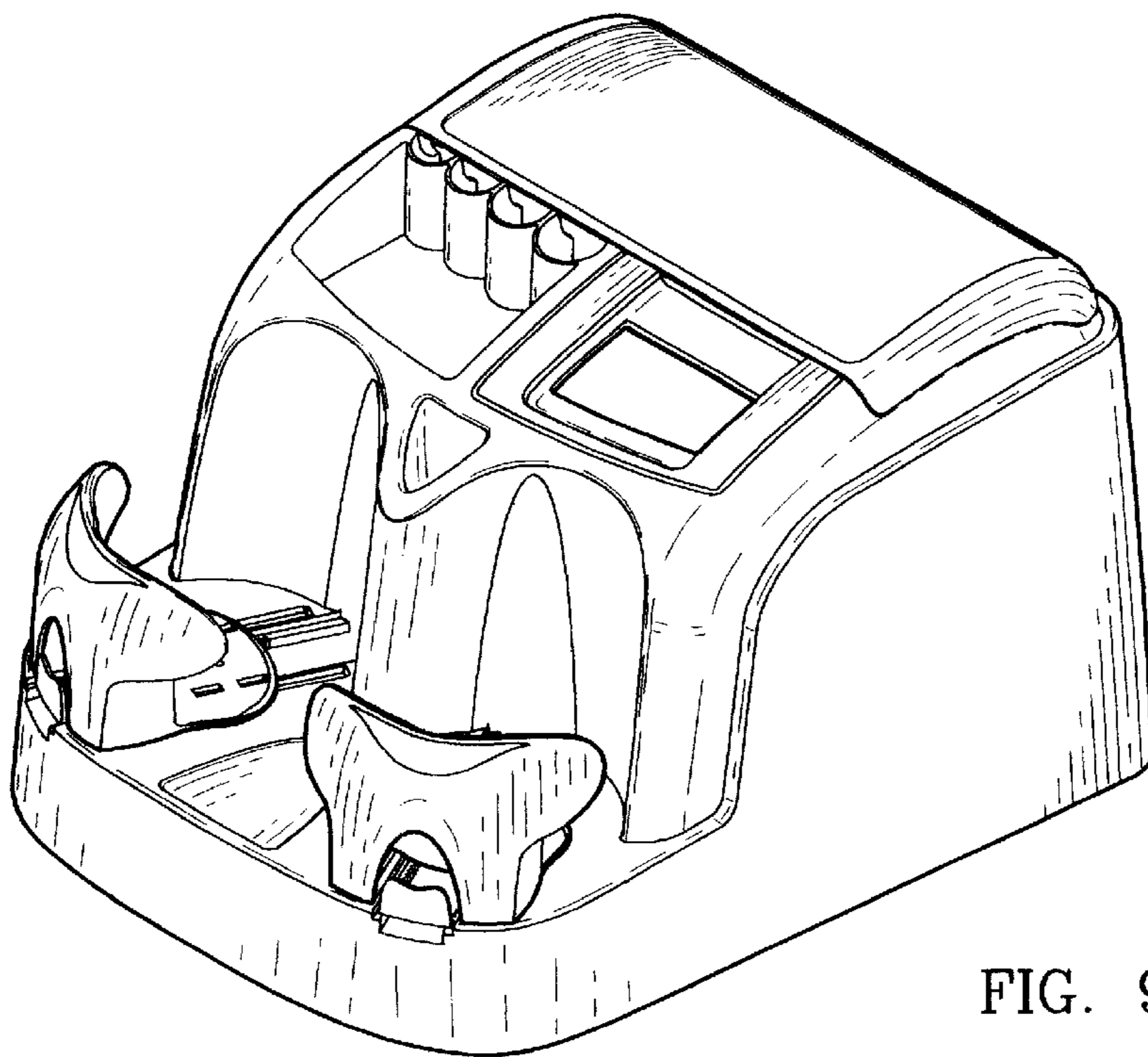

FIG. 9

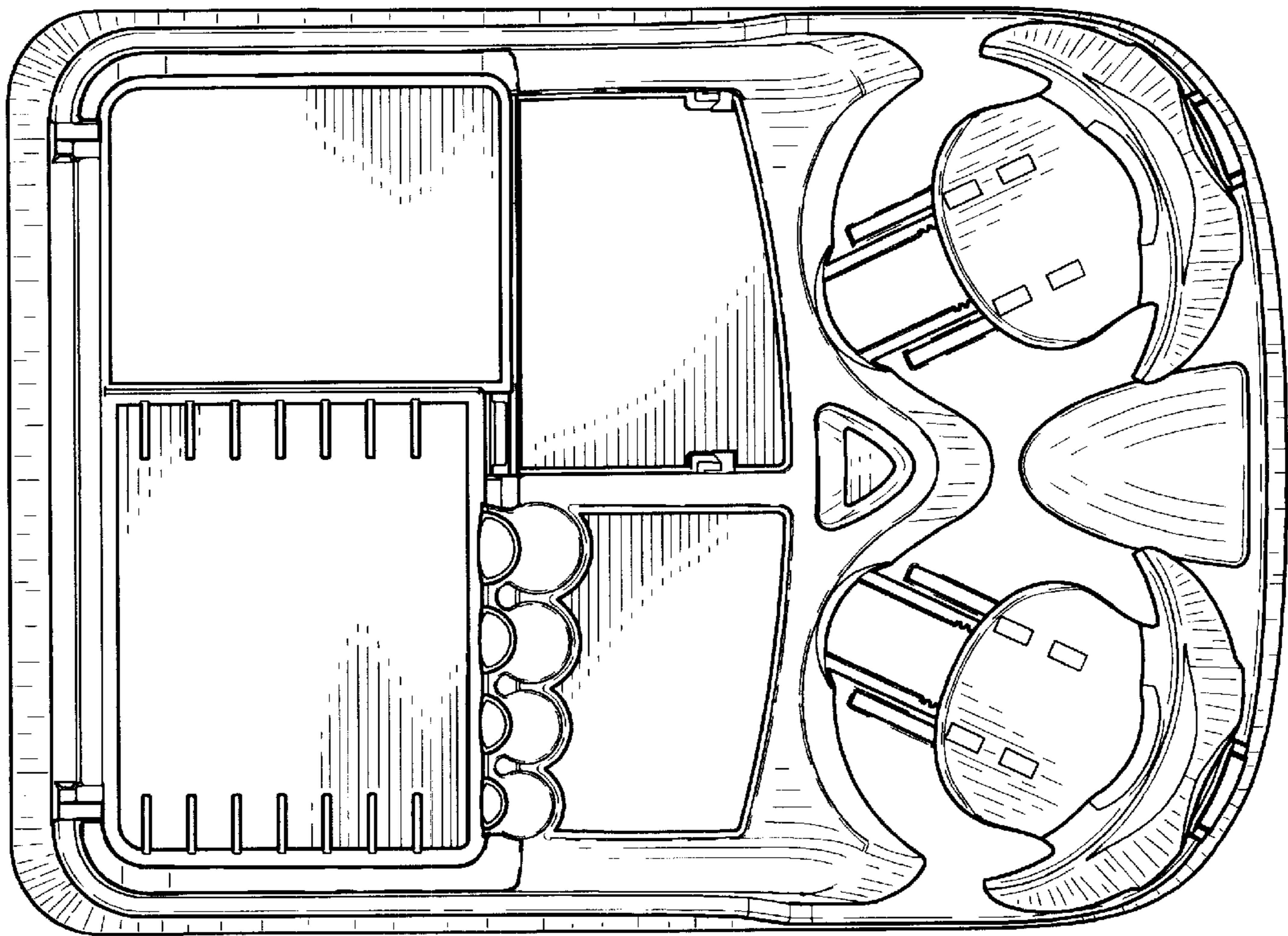

FIG. 10

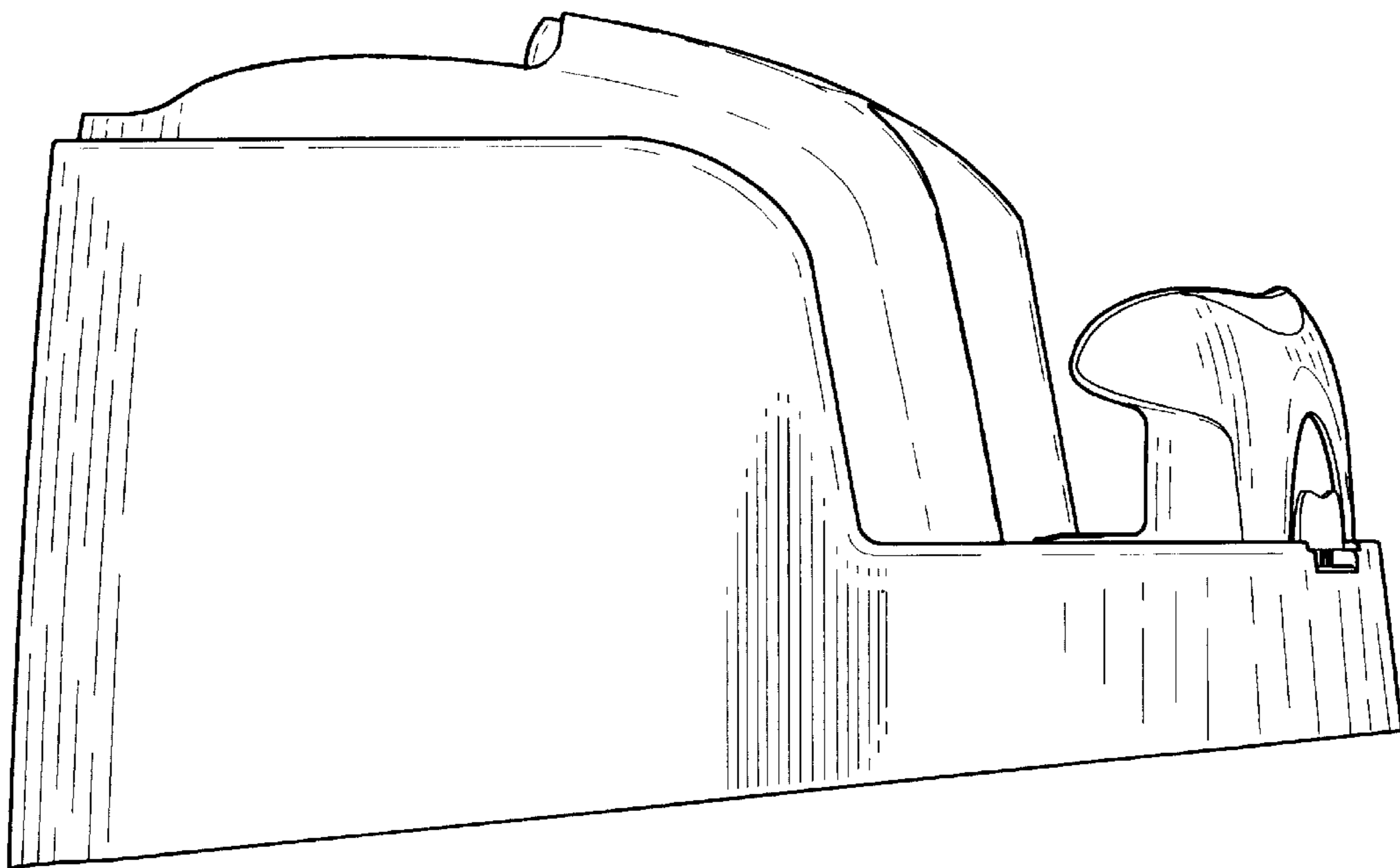

FIG. 11

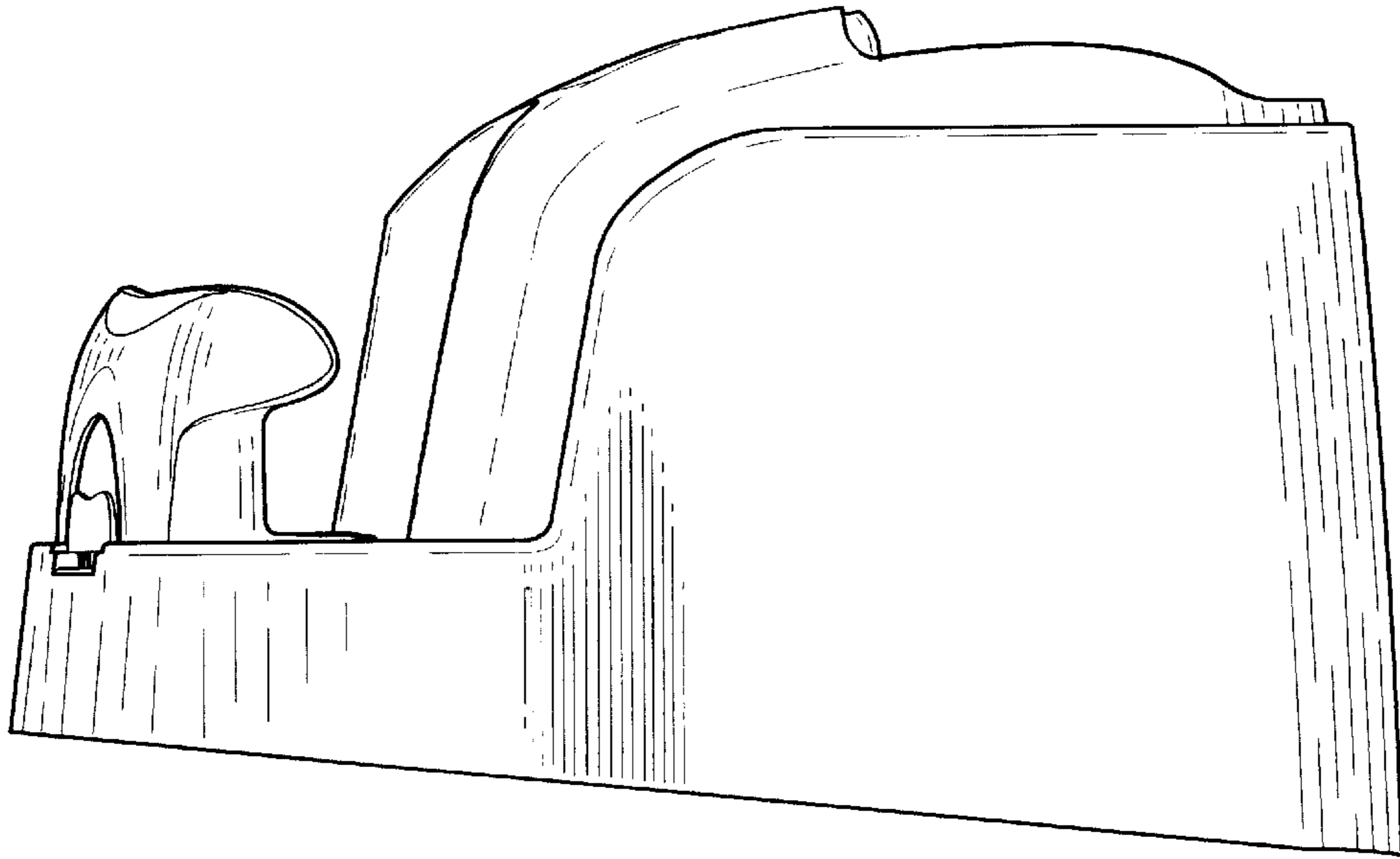

FIG. 12

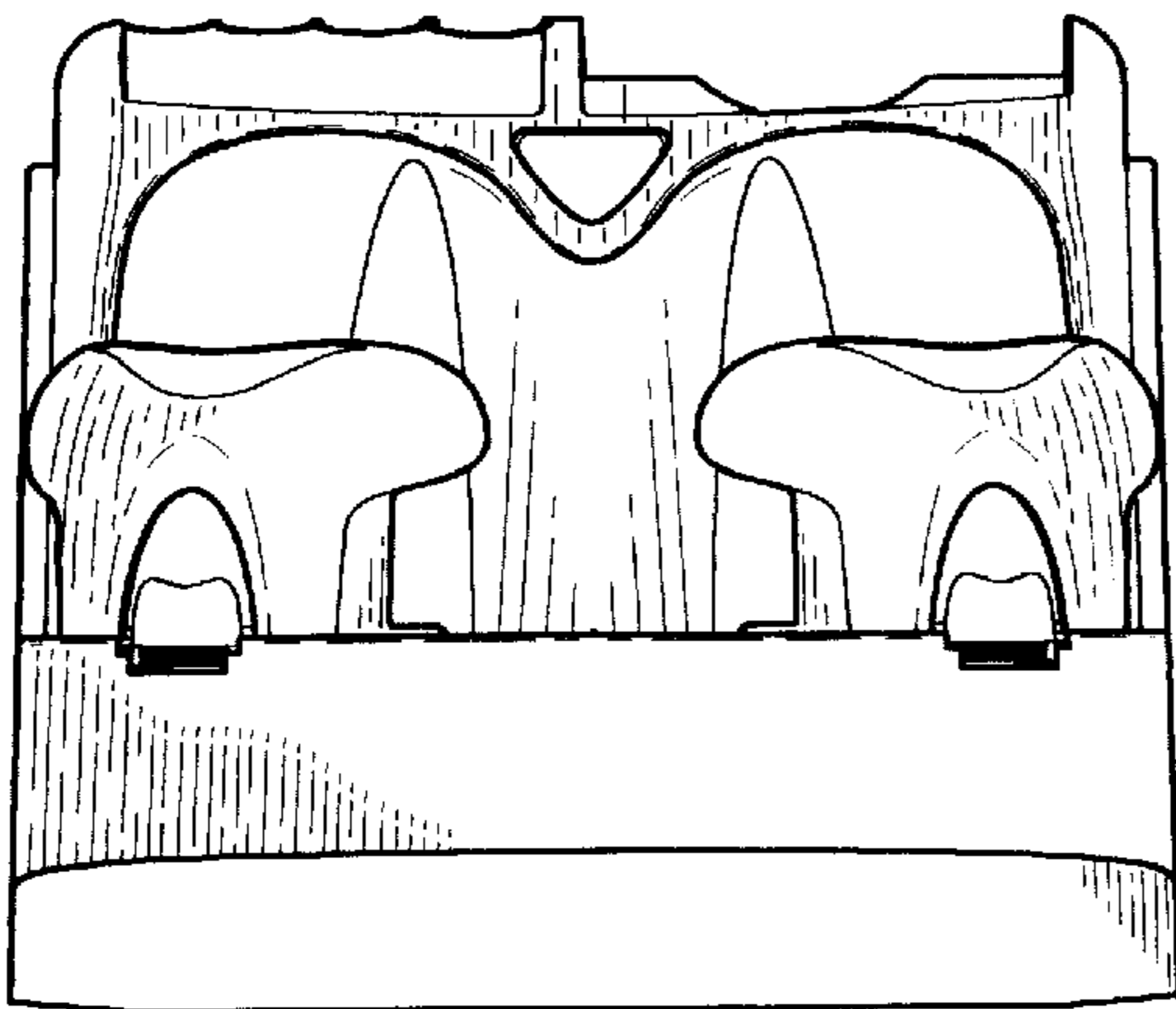

FIG. 13

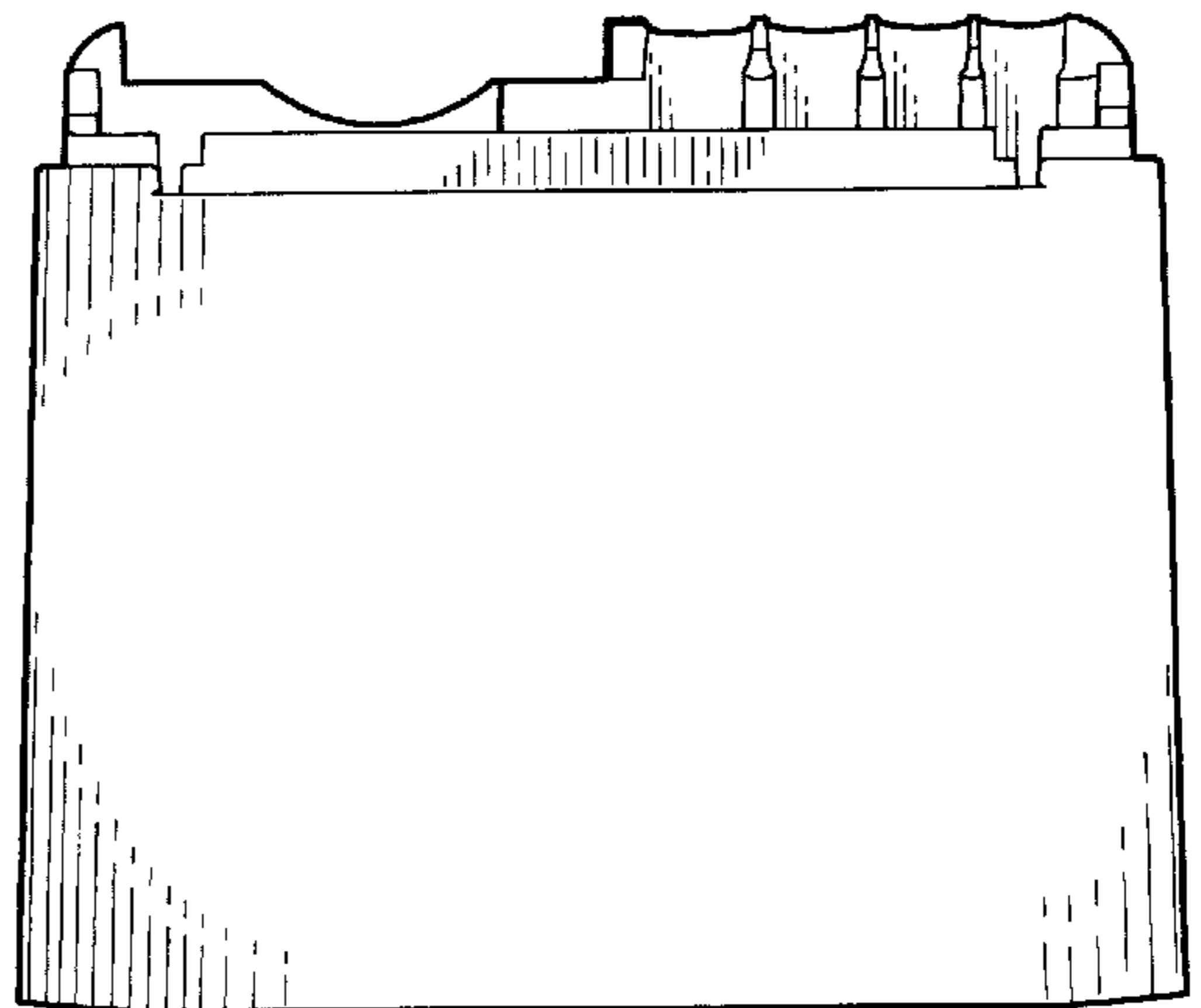

FIG. 14