



US00D461158S

(12) **United States Design Patent**  
**Tomatsu**

(10) **Patent No.:** **US D461,158 S**

(45) **Date of Patent:** **\*\* Aug. 6, 2002**

(54) **AWNING FOR CRUISER FLYING DECK**

(76) Inventor: **Seizou Tomatsu**, 54-2, Harusato-cho 2  
chome, Chikusa-ku, Nagoya-shi,  
Aichi-ken, 464-0038 (JP)

(\*\*) Term: **14 Years**

(21) Appl. No.: **29/139,672**

(22) Filed: **Apr. 4, 2001**

(30) **Foreign Application Priority Data**

Oct. 6, 2000 (JP) ..... 2000-028277

(51) **LOC (7) Cl.** ..... **12-06**

(52) **U.S. Cl.** ..... **D12/317**

(58) **Field of Search** ..... D12/300-317;  
417/361

(56) **References Cited**

**U.S. PATENT DOCUMENTS**

2,821,989 A \* 2/1958 Shepard ..... 114/361  
4,926,782 A \* 5/1990 Lacy ..... 114/361

\* cited by examiner

*Primary Examiner*—Lisa Lichtenstein

(74) *Attorney, Agent, or Firm*—Flynn, Thiel, Boutell &  
Tanis, P.C.

(57) **CLAIM**

The ornamental design for an awning for cruiser flying deck,  
as shown and described herein.

**DESCRIPTION**

FIG. 1 is a side view of the awning for cruiser flying deck

embodying my design, the other side being substantially a  
mirror image thereof;

FIG. 2 is a top plan view thereof;

FIG. 3 is a bottom plan view thereof;

FIG. 4 is a front view thereof;

FIG. 5 is a rear view thereof;

FIG. 6 is a sectional view along line 6—6 in FIG. 2 and  
showing the transparent window panel in a closed position;

FIG. 7 is a sectional view along line 6—6 in FIG. 2 and  
showing the transparent window panel in an opened posi-  
tion;

FIG. 8 is an enlarged reference drawing showing the con-  
dition of use as viewed from the side;

FIG. 9 is a reference drawing of the condition of use as  
viewed from the side;

FIG. 10 is a reference drawing of the condition of use as  
viewed from above; and,

FIG. 11 is a reference drawing of the condition of use as  
viewed from the front.

The broken line showing of environmental structure in  
FIGS. 8-11 is for illustrative purposes only and forms no  
part of the claimed design.

**1 Claim, 6 Drawing Sheets**

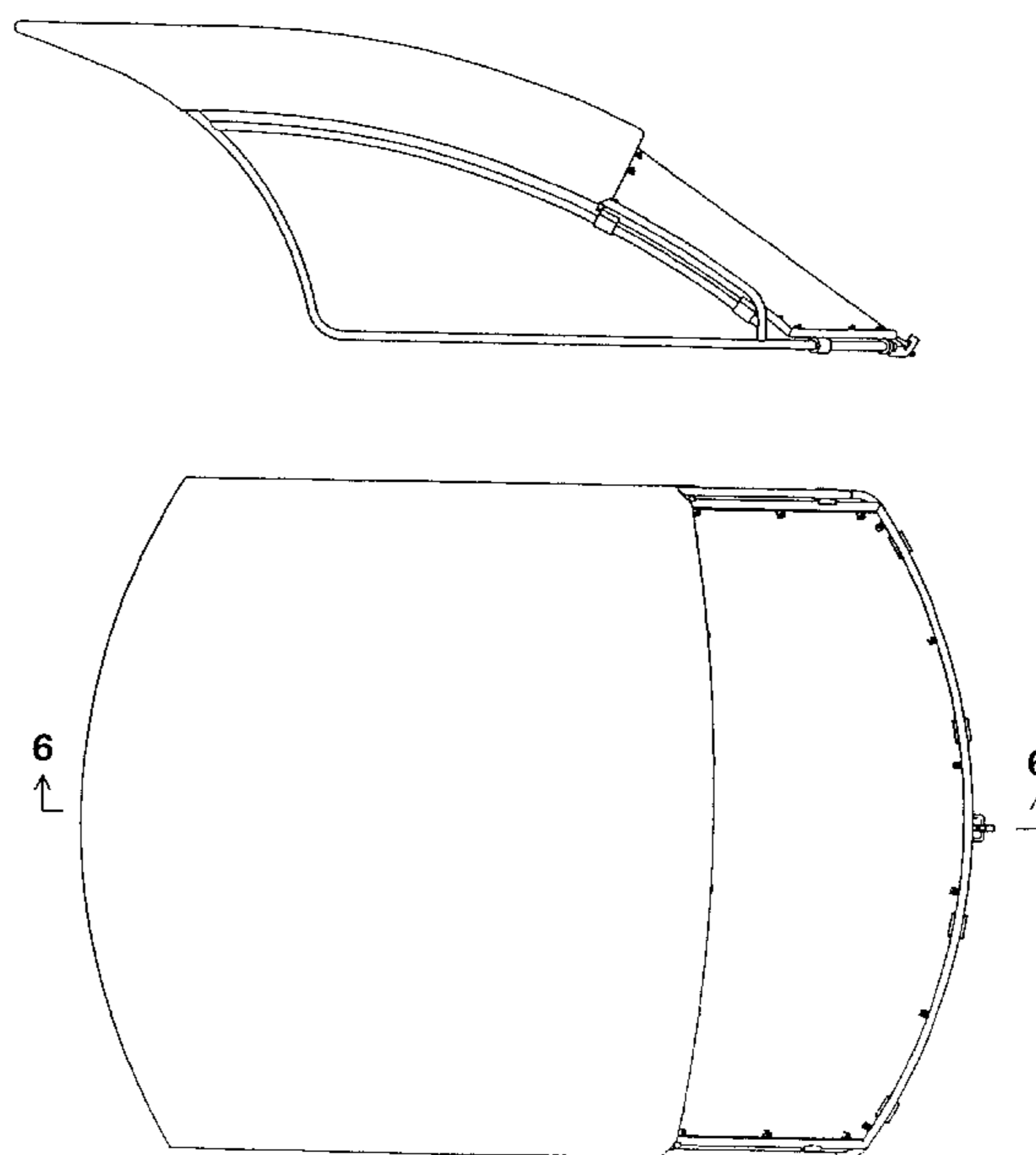

Fig.1

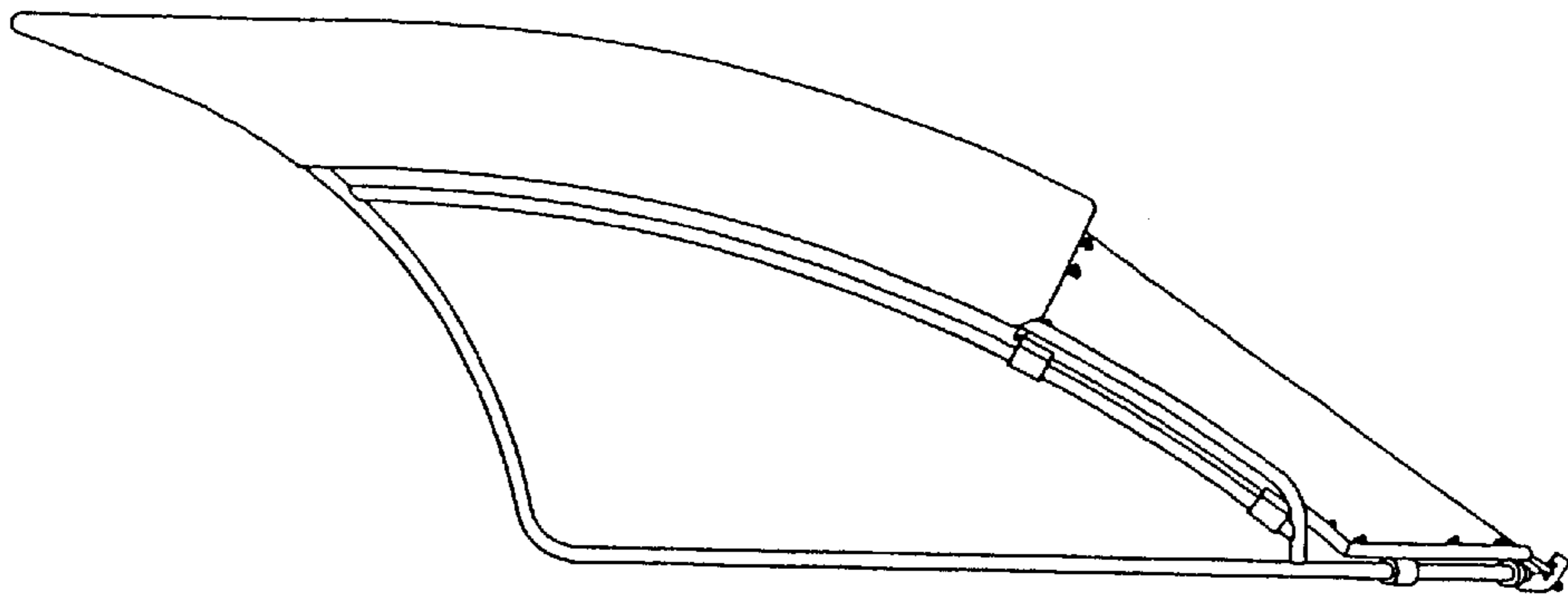

Fig.2

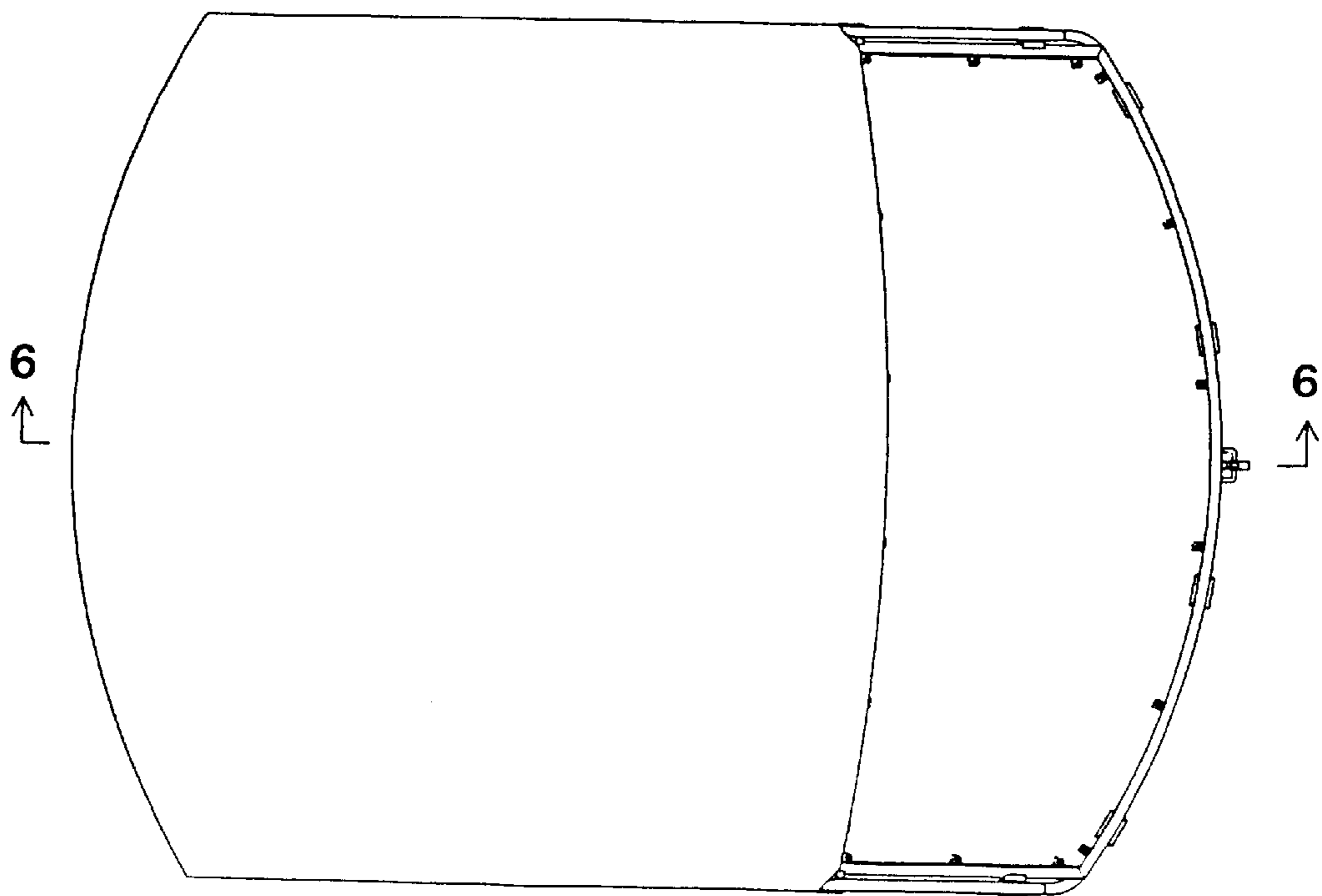

Fig.3

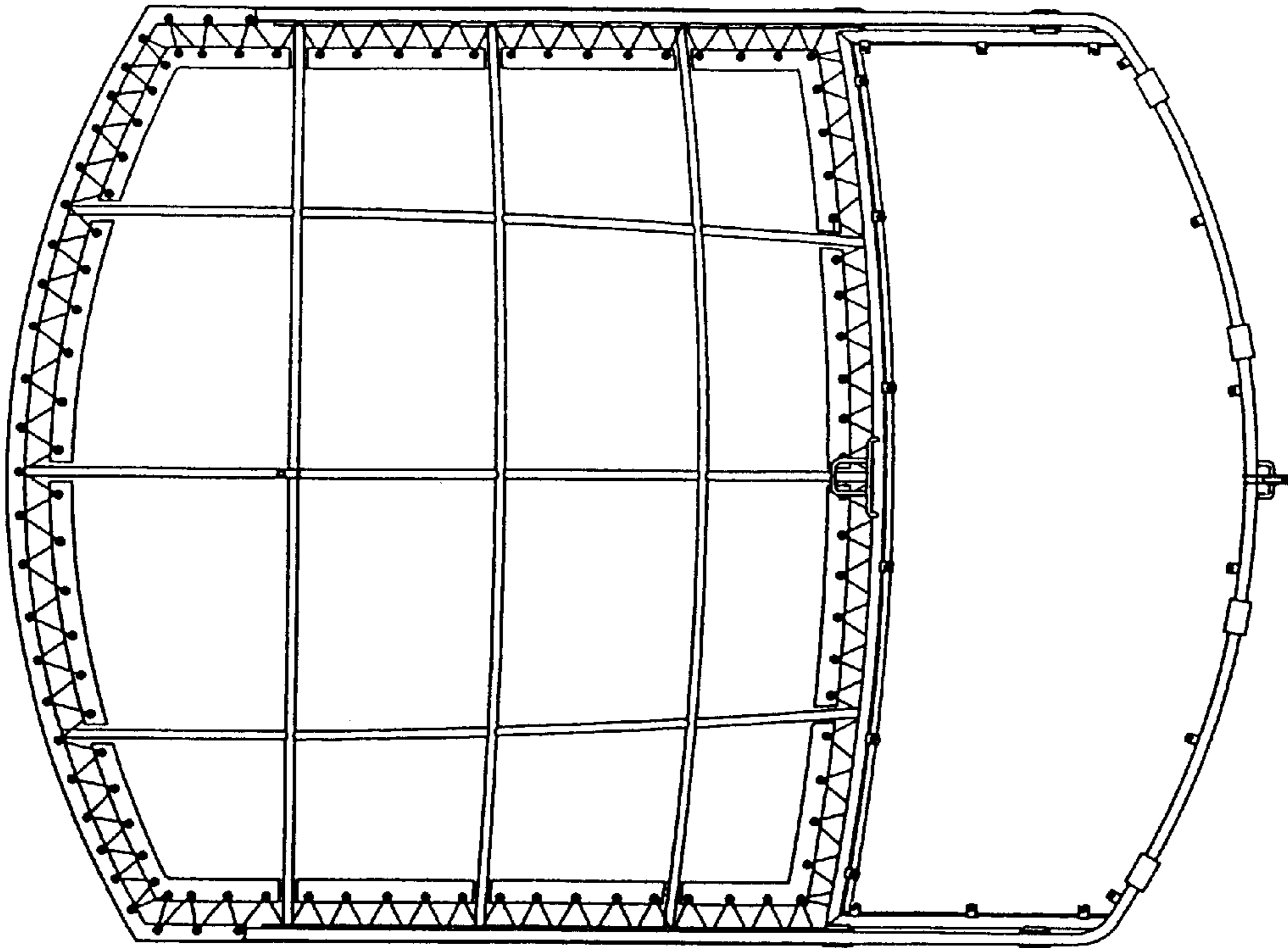

Fig.4

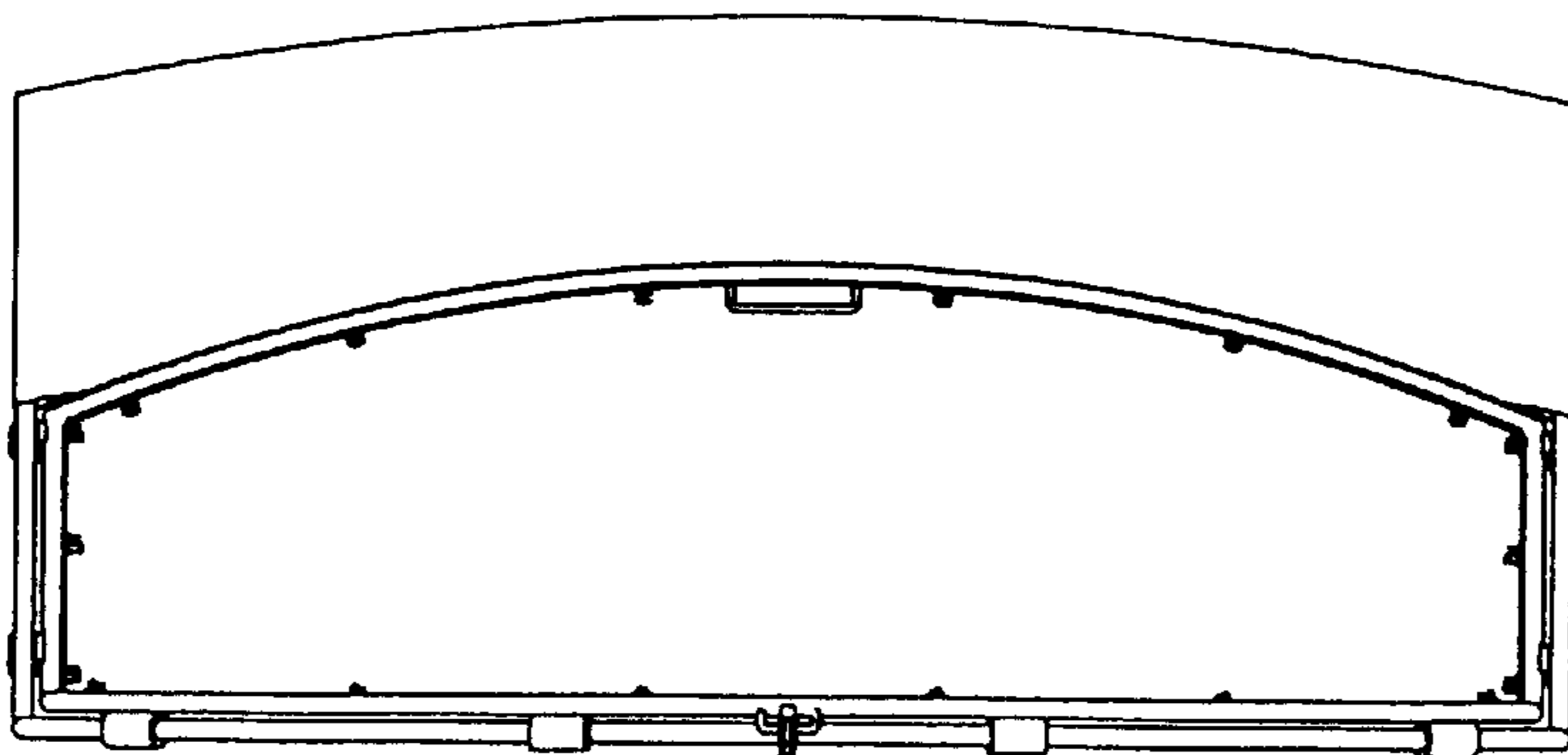

Fig.5

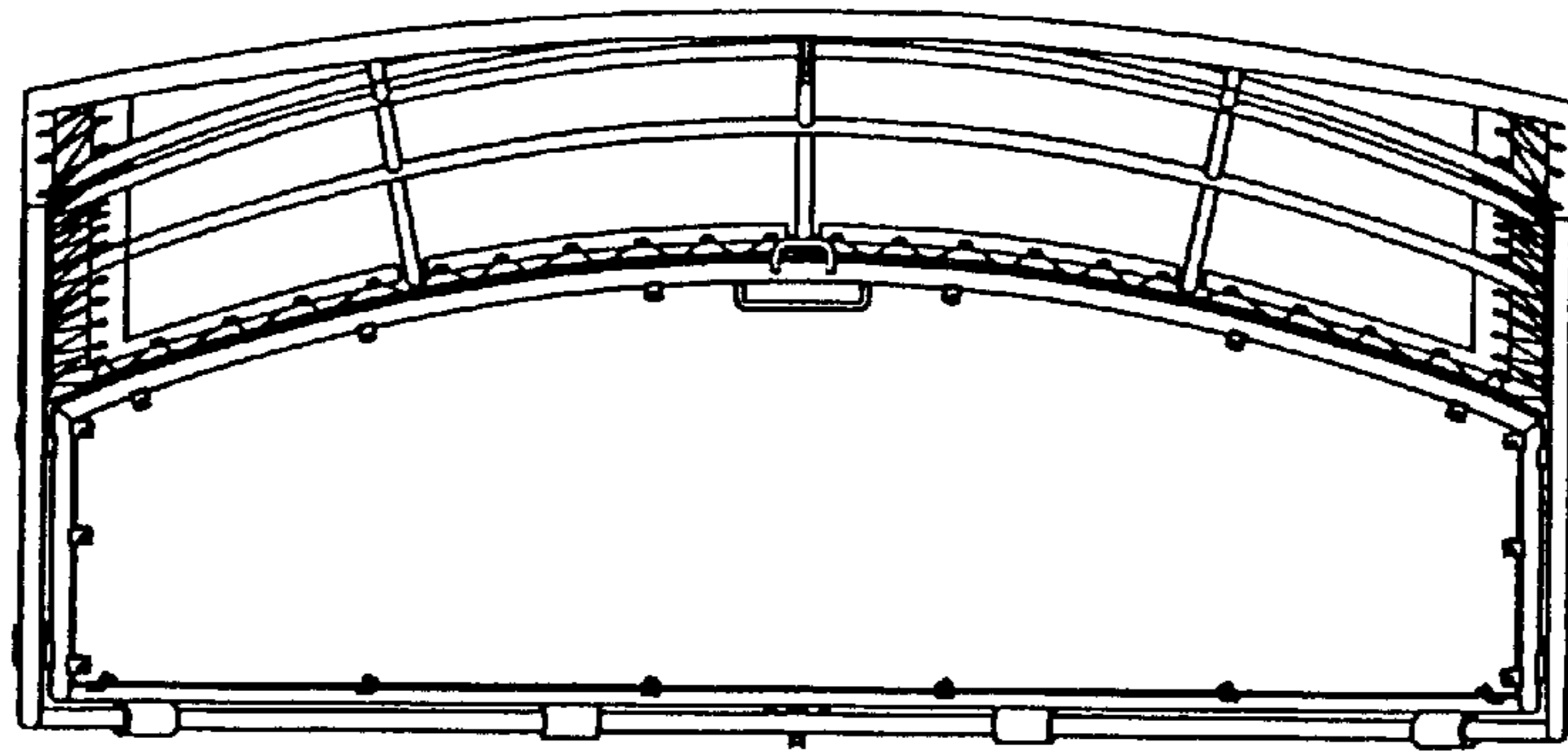

Fig.6

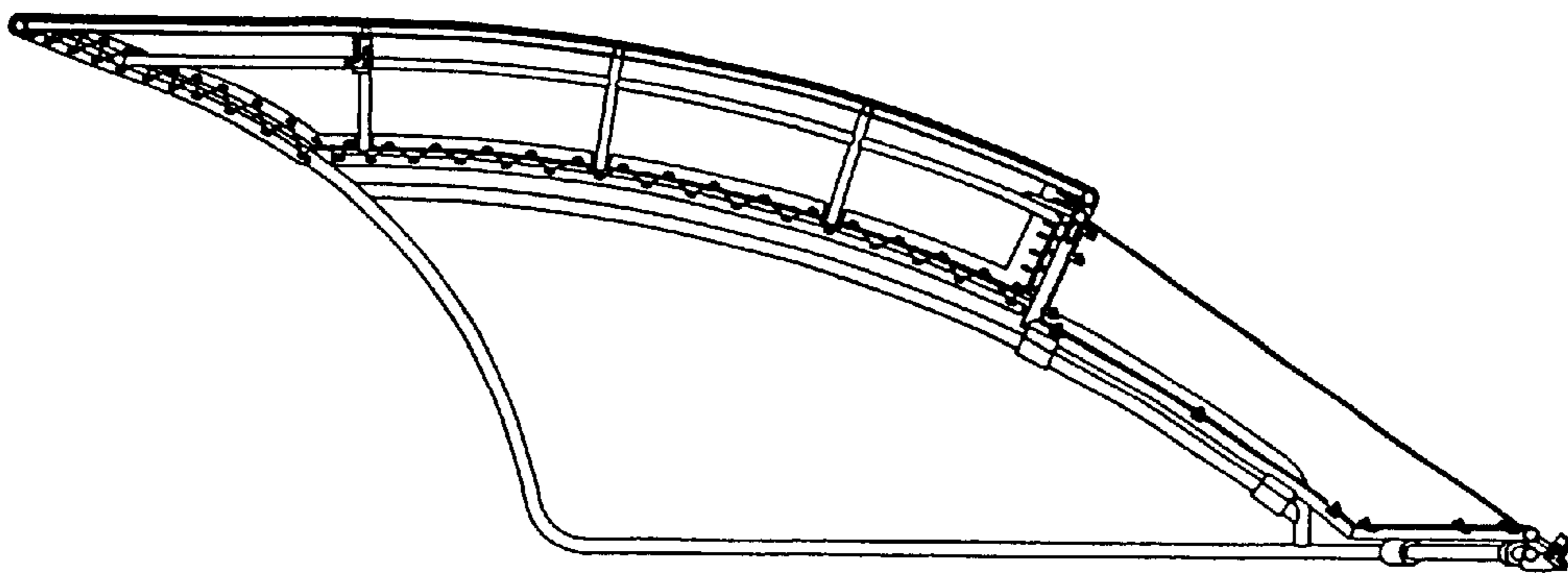

Fig.7

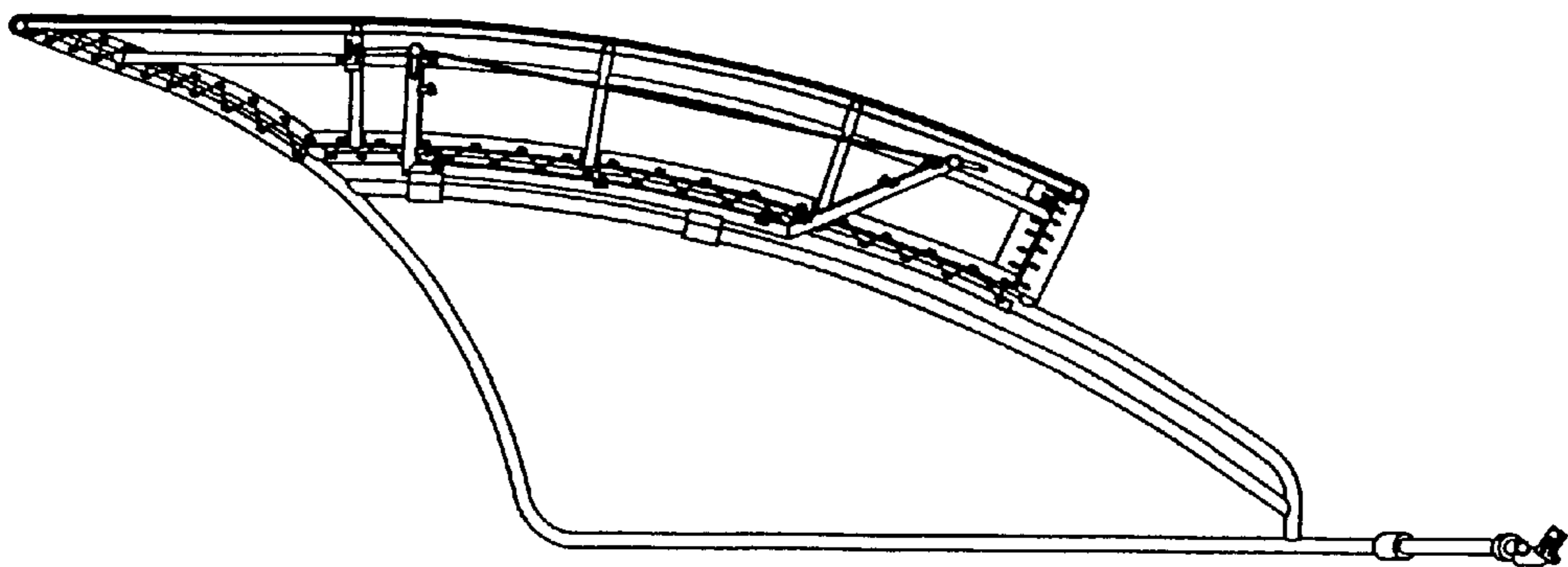

Fig.8

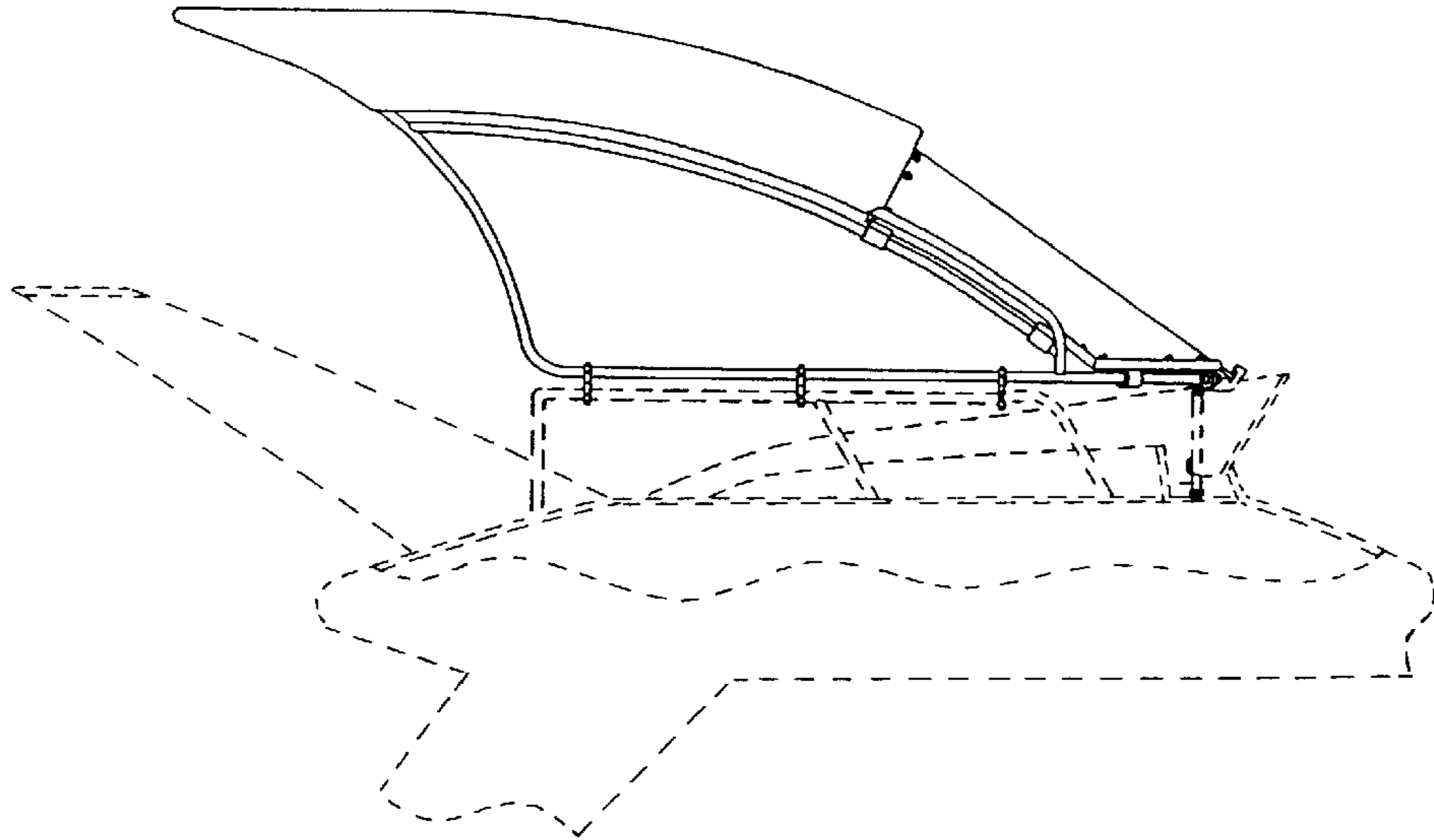

Fig.9

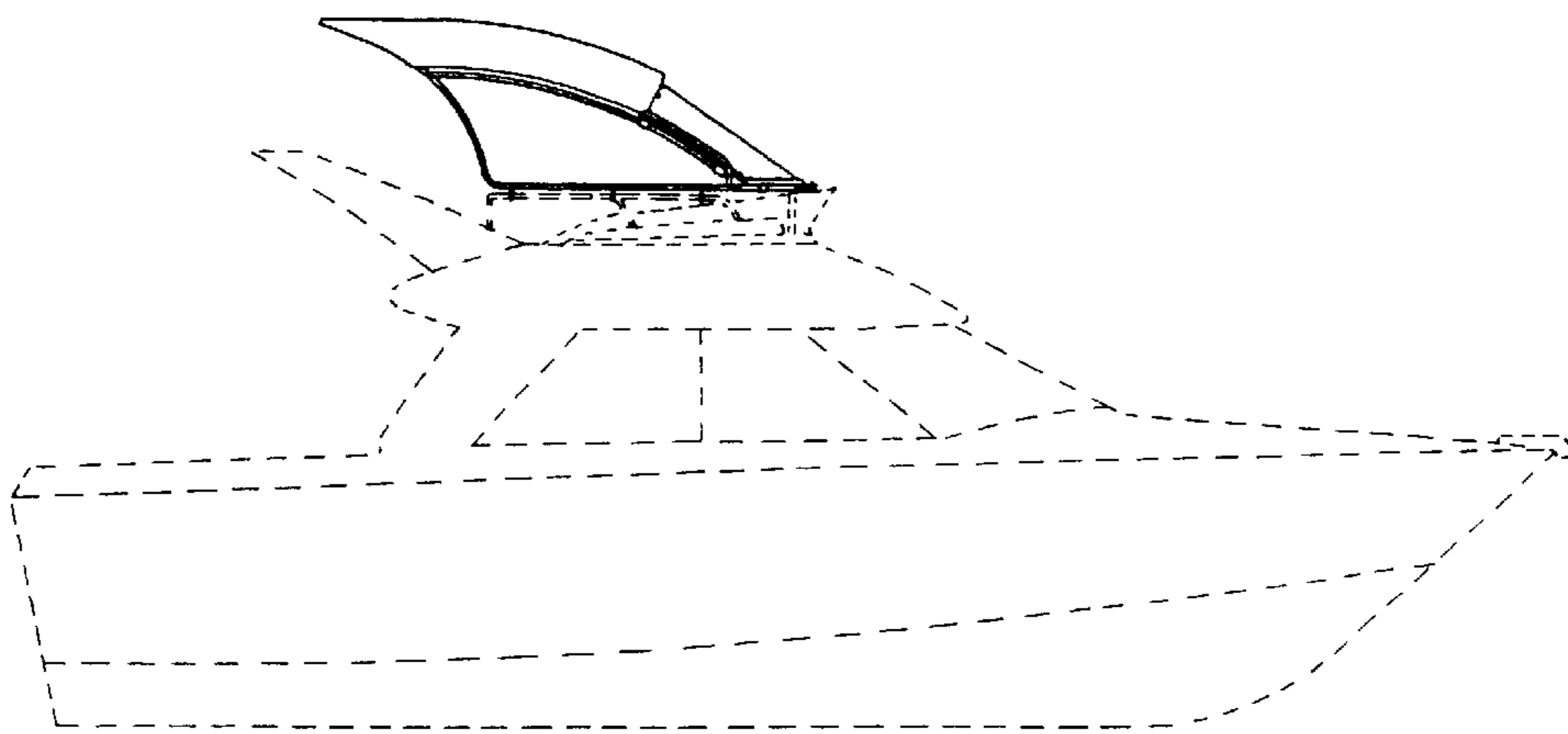

Fig.10

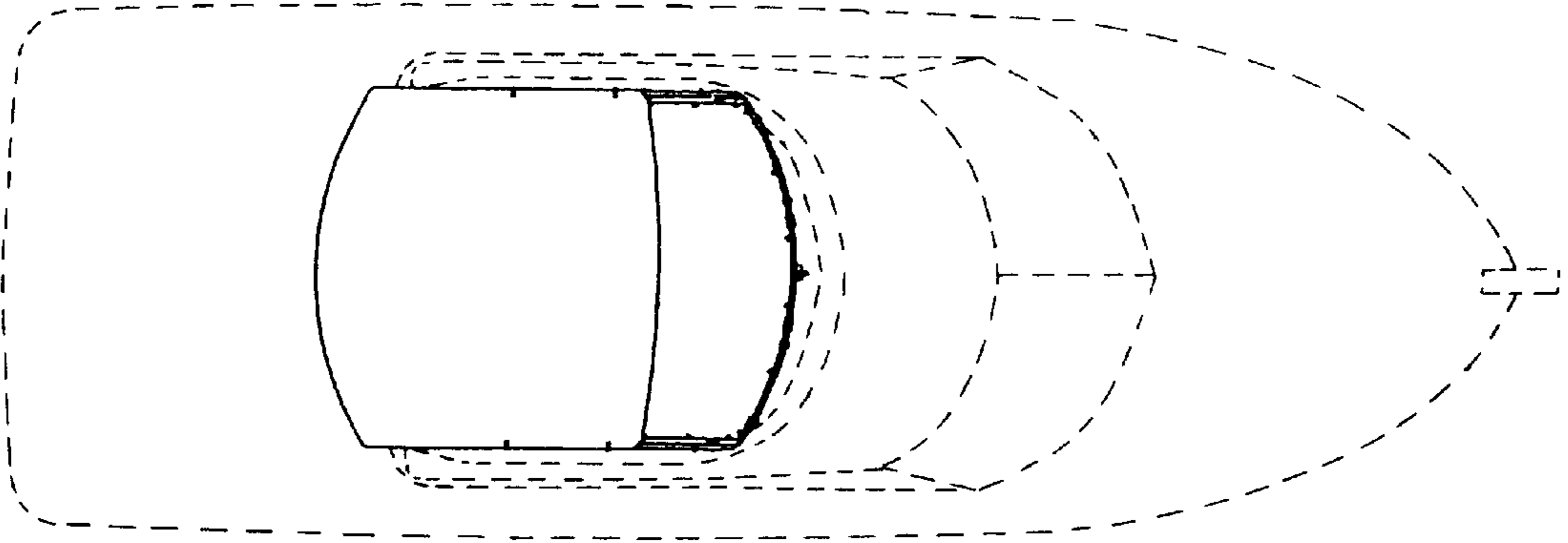

Fig.11

