



US00D461157S

(12) **United States Design Patent**
Myers et al.

(10) **Patent No.: US D461,157 S**

(45) **Date of Patent: ** Aug. 6, 2002**

(54) **MOTORCYCLE RADIATOR COVER**

(75) Inventors: **John Myers**, Glendale; **Frank Savage**, Germantown, both of WI (US)

(73) Assignee: **Harley-Davidson Motor Company Group, Inc.**, Milwaukee, WI (US)

(**) Term: **14 Years**

(21) Appl. No.: **29/144,711**

(22) Filed: **Jul. 9, 2001**

(51) **LOC (7) Cl.** **12-12**

(52) **U.S. Cl.** **D12/216**

(58) **Field of Search** D12/110, 114, D12/126, 163, 216, 166, 171; D23/395; 123/41.04; 165/148-153, 41-44, 98; 180/68.4, 68.3, 68.6, 69.24, 219, 229, 903; 280/288.4, 304.3; 237/79

(56) **References Cited**
PUBLICATIONS

A photograph of a motorcycle, published in "Enthusiast: Sportster® Over L.A.," the publication has a copyright date of 1998, p. 23, published prior to Jul. 9, 2001.

A photograph of a "Softail Air Dam Tool Box, a photograph of a Sportster Color-matched Front Spoiler," and two photographs of "Color-matched Front Spoilers" published in "Harley-Davidson®: 1999 Genuine Motor Accessories™ & Genuine Motor Parts™," the publication has a copyright date of the 1998, p. 199, 390, and 391, prior to Jul. 9, 2001. A photograph of a 1989 XL-1200 Sportster®, published in "Harley-Davidson Motor Company: Accessories '90," p. 3, the publication was printed in Feb. 1990, p. 3.

Photographs of "Chin Fairings and Air Dams," published in "2001 J & P Cycles: Parts & Accessories for Harley-Davidson® Motorcycles," p. 352, prior to Jul. 9, 2001.

A photograph of a "Dyna Color-matched Front Spoiler," a photograph of a "Softail Color-matched Front Spoiler for 2000 Models," a photograph of a "Softail Color-matched Front Spoiler for 1992-1999 Models," and four photographs of "front spoilers," published in "Harley-Davidson®: 2000 Genuine Motor Accessories and Genuine Motor Parts," the publication has a copyright date of 2000, pp. 174, 231 534, and 535, prior to Jul. 9, 2001.

Three photographs of "Front Spoilers," published in "Harley-Davidson®: 2000 Genuine Motor Accessories and Genuine Motor Parts Spring Supplement," the publication has a copyright date of 2000, p. 93, prior to Jul. 9, 2001.

A photograph of a 2001 Softail® Deuce™ FXSTD and a photograph of a 2001 Night Train™ FXSTBI, published in "Harley-Davidson: 2001 Genuine Motor Accessories and Genuine Motor Parts," pp. 246-247, and 250, prior to Jul. 9, 2001.

A side view of a 1992 XLH Sportster® 883 Deluxe, published in "Harley-Davidson Motorcycles®: Genuine 1992 Accessories," the publication has a copyright date of 1992, p. 4, published prior to Jul. 9, 2001.

Three photographs of "chin Fairings" and a photograph of a "Full-Length Vented Air Scoops," published in "94 Custom Chrome Catalog," the publication has a copyright date of 1993, p. 603, published prior to Jul. 9, 2001.

Primary Examiner—Alan P. Douglas

Assistant Examiner—Linda Brooks

(74) *Attorney, Agent, or Firm*—Michael Best & Friedrich LLP

(57) **CLAIM**

We claim the ornamental design for a motorcycle radiator cover, as shown and described.

DESCRIPTION

FIG. 1 is a perspective view of the motorcycle radiator cover, shown in position of use from the right side of a motorcycle.

FIG. 2 is an enlarged front view of the motorcycle radiator cover; and,

FIG. 3 is a left side view of the motorcycle radiator cover shown in FIG. 2.

The broken line showing of the environment is for illustrative purposes only and forms no part of the claimed design.

1 Claim, 2 Drawing Sheets

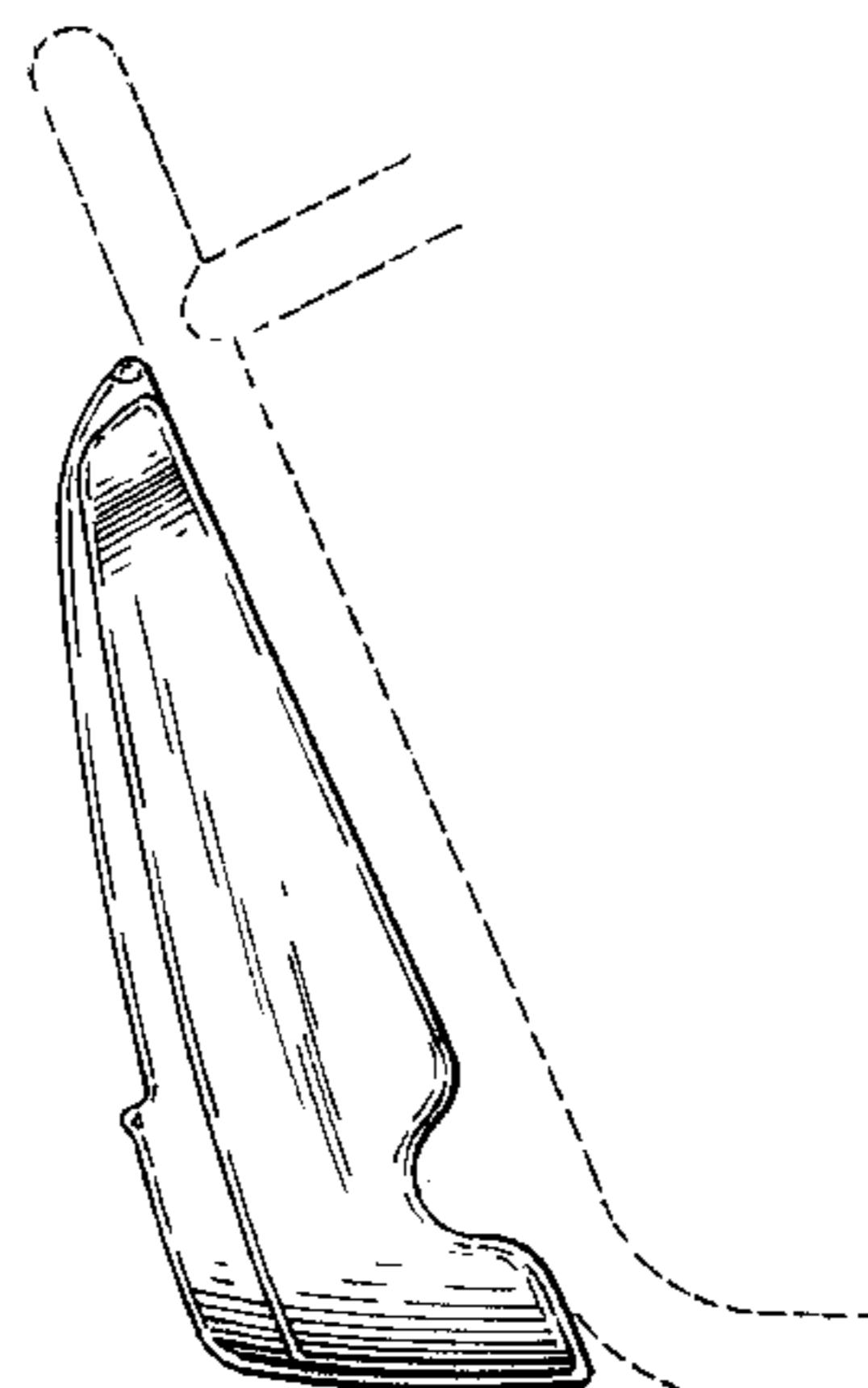
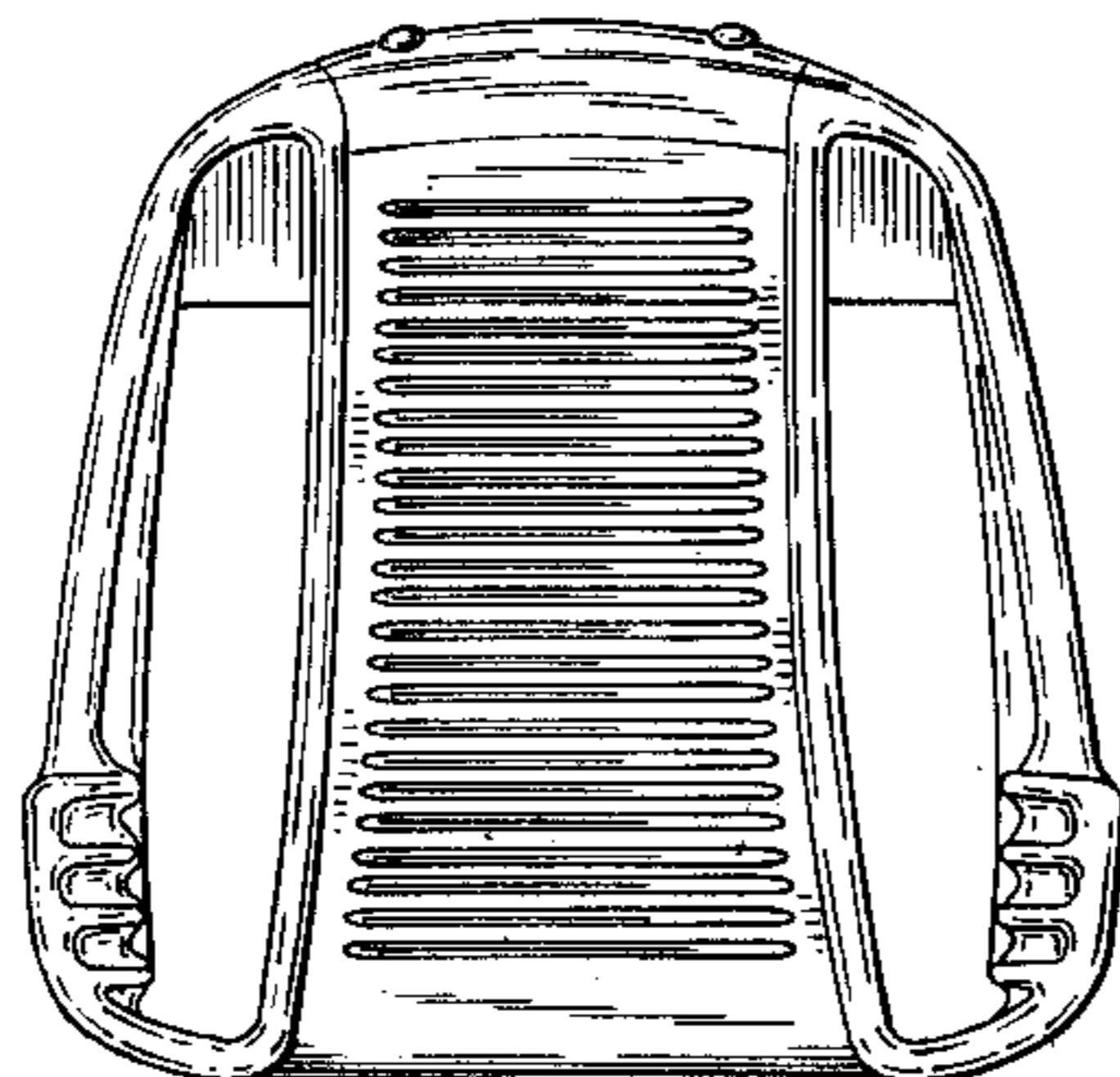

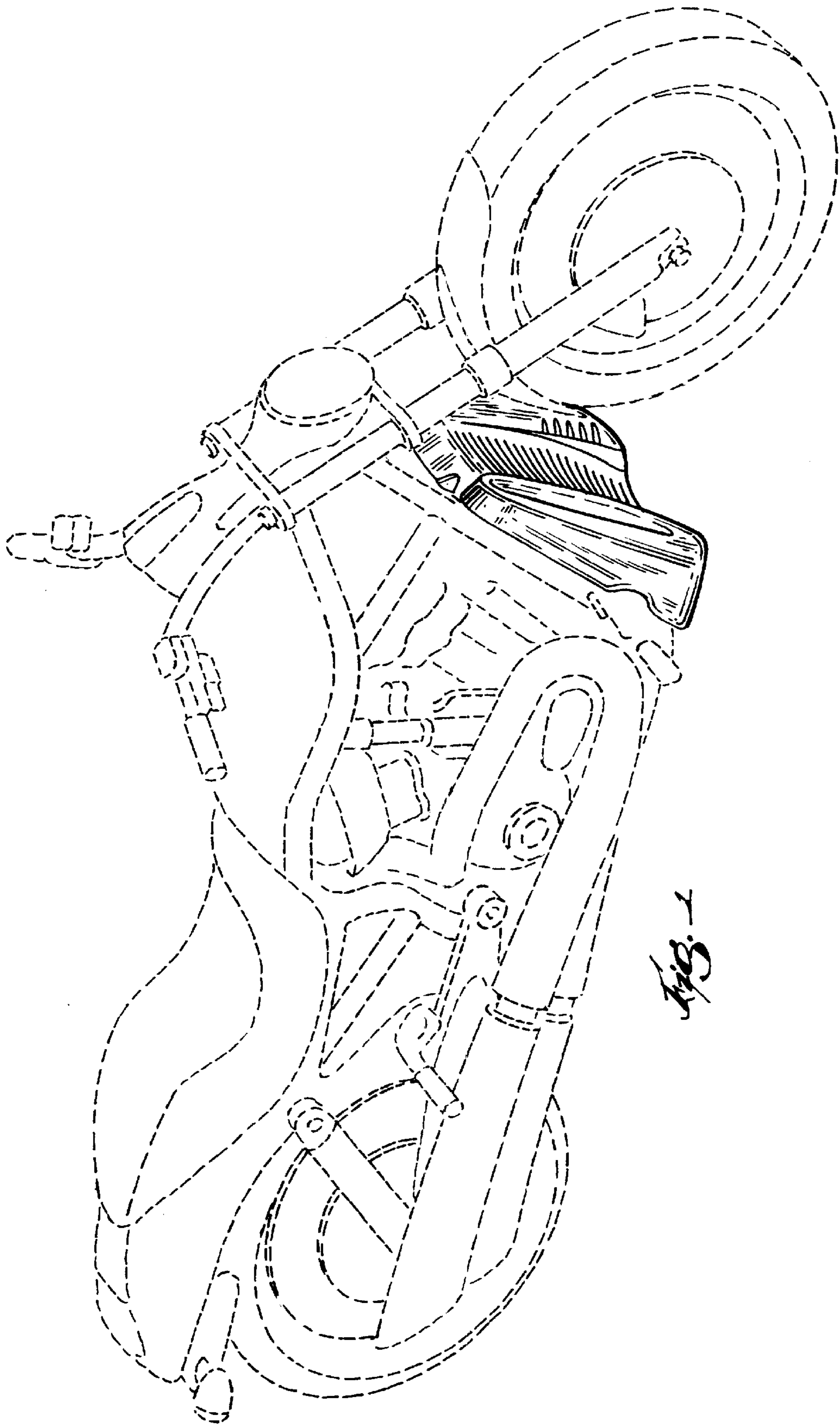

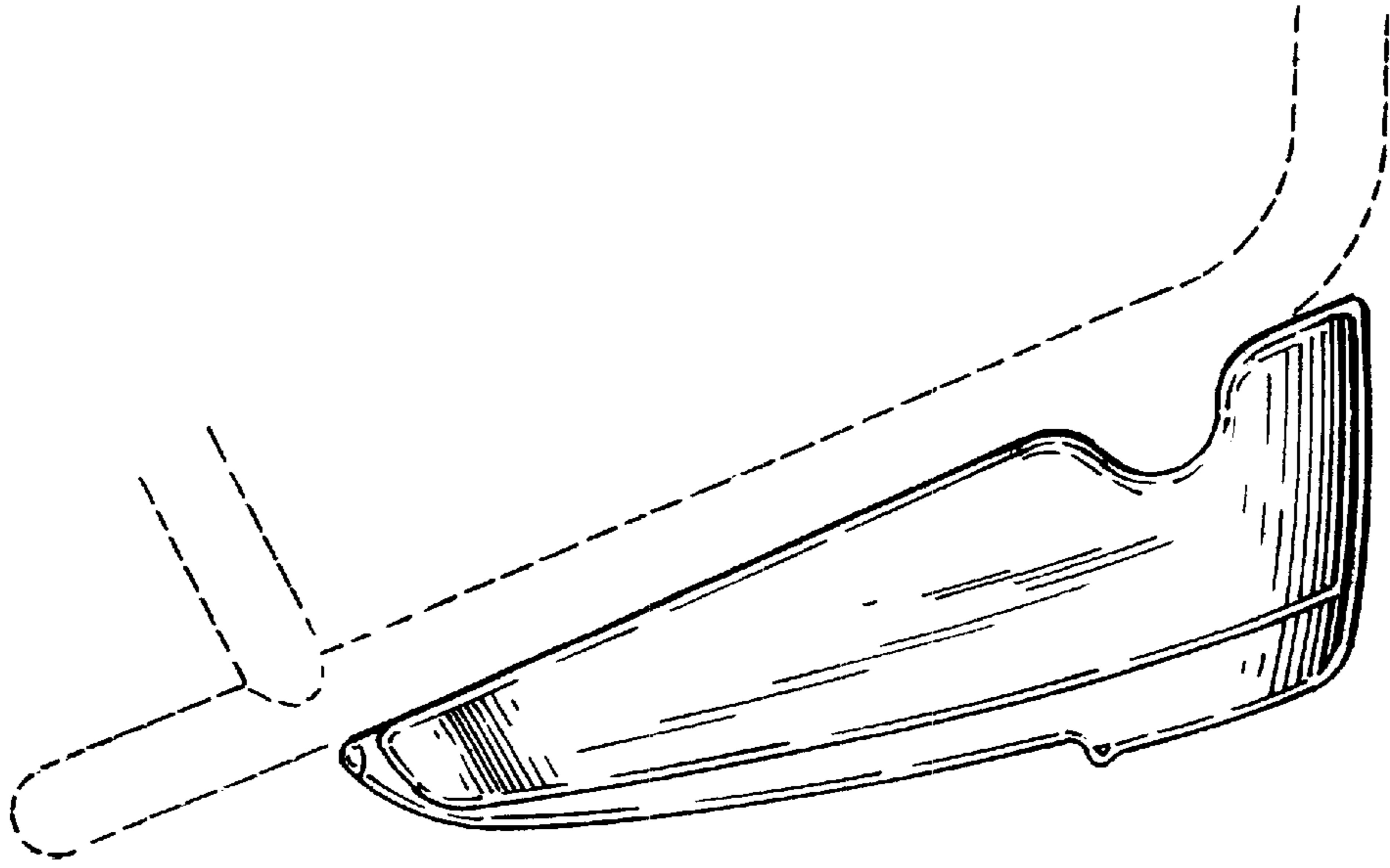

Fig. 3

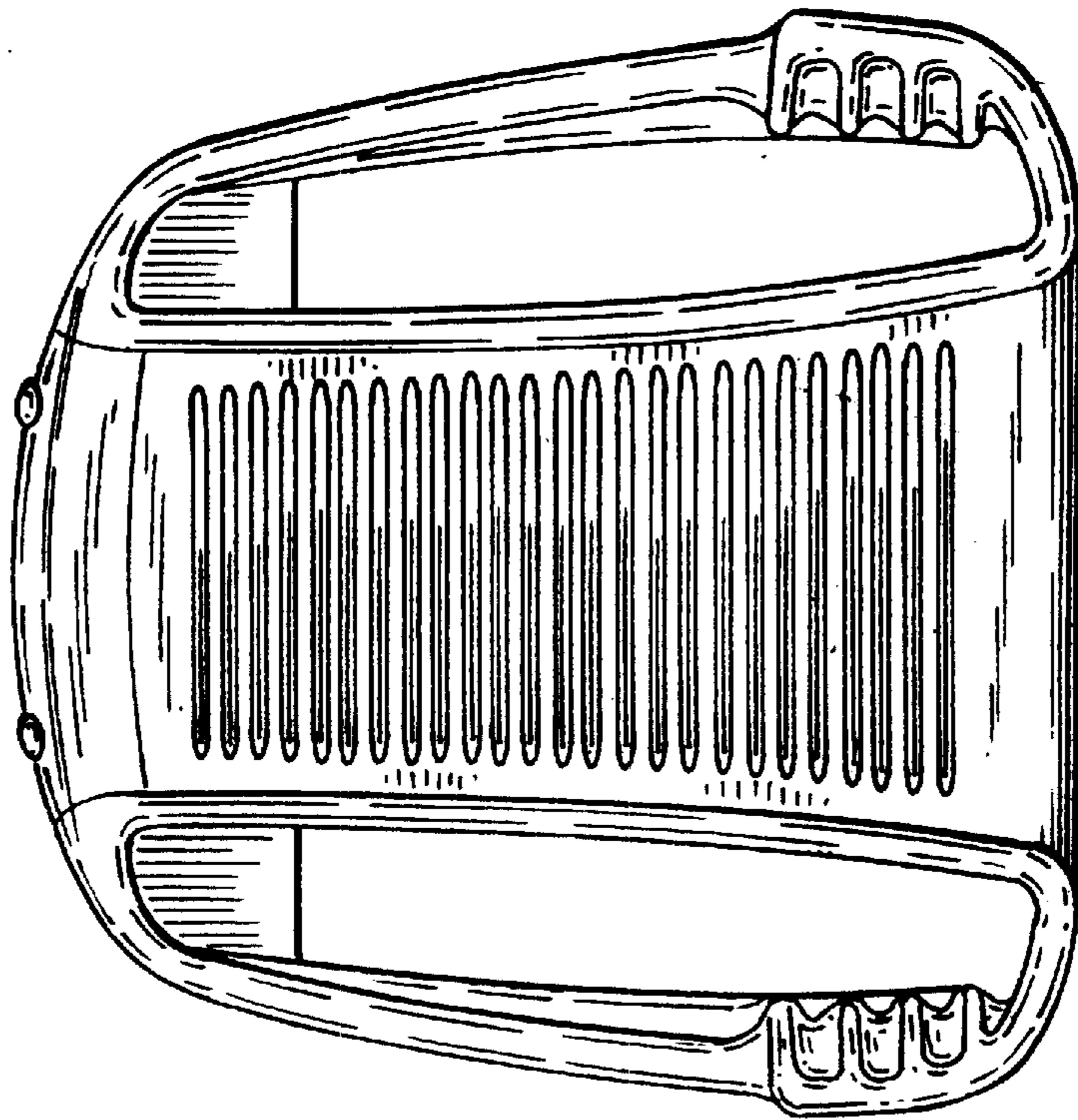

Fig. 2