



US00D461064S

(12) **United States Design Patent**
Fogderud

(10) **Patent No.:** **US D461,064 S**

(45) **Date of Patent:** **** Aug. 6, 2002**

(54) **MUSICIAN'S PERFORMANCE CHAIR**

(76) Inventor: **Tim Fogderud**, 2511 N. 4th St.,
Bismarck, ND (US) 58501-0486

(**) Term: **14 Years**

(21) Appl. No.: **29/146,306**

(22) Filed: **Aug. 8, 2001**

(51) **LOC (7) Cl.** **06-01**

(52) **U.S. Cl.** **D6/363; D6/375**

(58) **Field of Search** D6/334, 363, 374,
D6/375, 500, 501, 502; 297/186, 445.1,
451.2, DIG. 2

4,275,714 A	6/1981	Lewis	
4,643,481 A	2/1987	Saloff et al.	
4,887,865 A	12/1989	Dawidzon	
D372,594 S	* 8/1996	Reese D6/363
D375,009 S	10/1996	Webb	
D420,841 S	* 2/2000	Keilhauer D6/502
6,086,157 A	7/2000	Toso	
D455,020 S	* 4/2002	Davis D6/374

* cited by examiner

Primary Examiner—Gary D. Watson

(74) *Attorney, Agent, or Firm*—Donald R. Schoonover

(57) **CLAIM**

The ornamental design for a musician's performance chair,
as shown and described.

(56) **References Cited**

U.S. PATENT DOCUMENTS

1,974,948 A	9/1934	Brown	
2,466,204 A	4/1949	Brown	
D180,934 S	* 9/1957	de Swart D6/363
D180,935 S	* 9/1957	de Swart D6/363
D182,245 S	* 3/1958	Rabin D6/363
D183,478 S	* 9/1958	Cohen D6/363
D197,713 S	* 3/1964	Bedser D6/363
D244,811 S	* 6/1977	Sternfield D6/375
D249,103 S	* 8/1978	Rodriquez D6/363

DESCRIPTION

FIG. 1 is a perspective view of the musician's performance chair embodying the design of the present invention. FIG. 2 is a front elevational view thereof; FIG. 3 is a rear elevational view thereof; FIG. 4 is a side elevational view thereof; FIG. 5 is a top plan view thereof; and, FIG. 6 is a bottom plan view thereof.

1 Claim, 4 Drawing Sheets

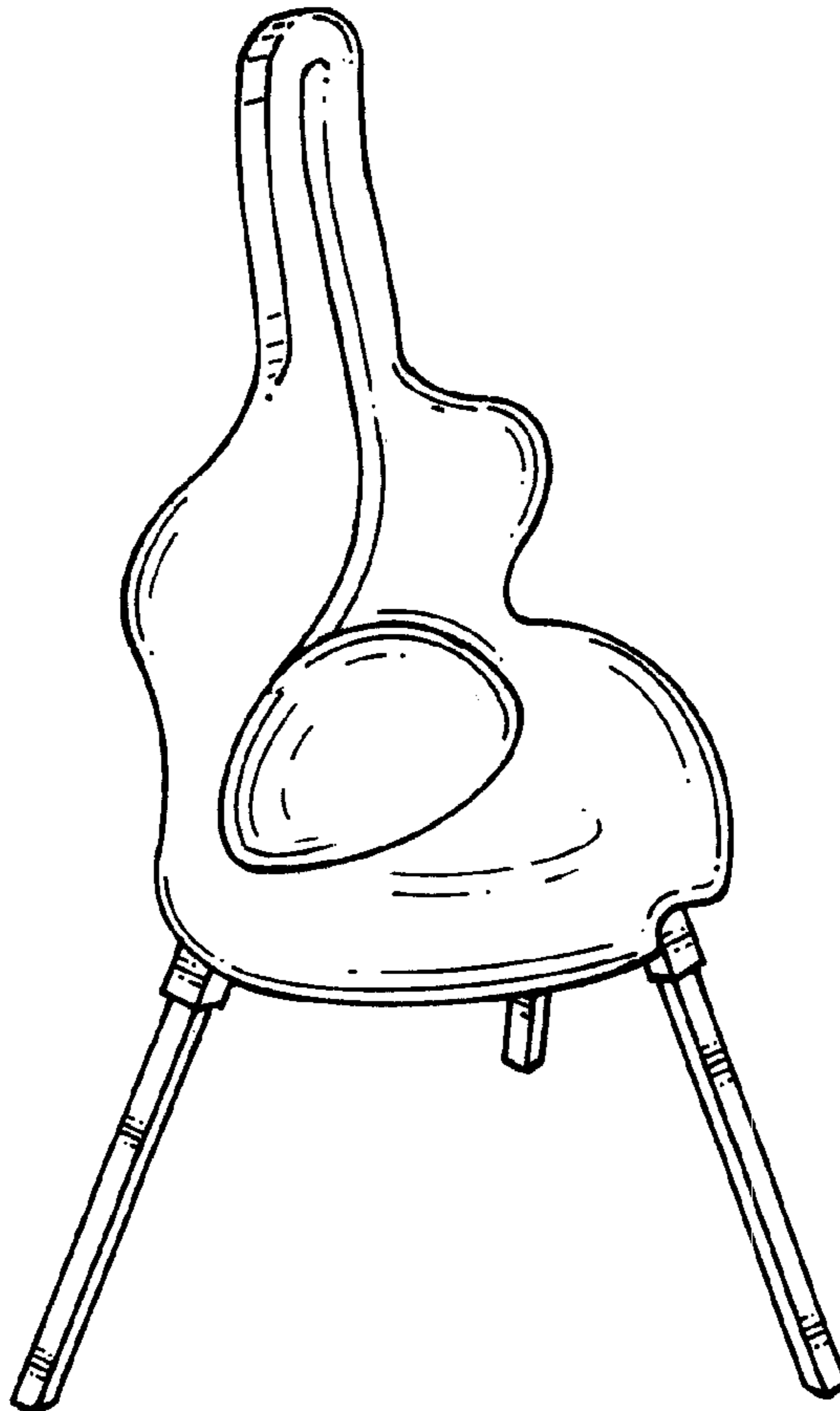

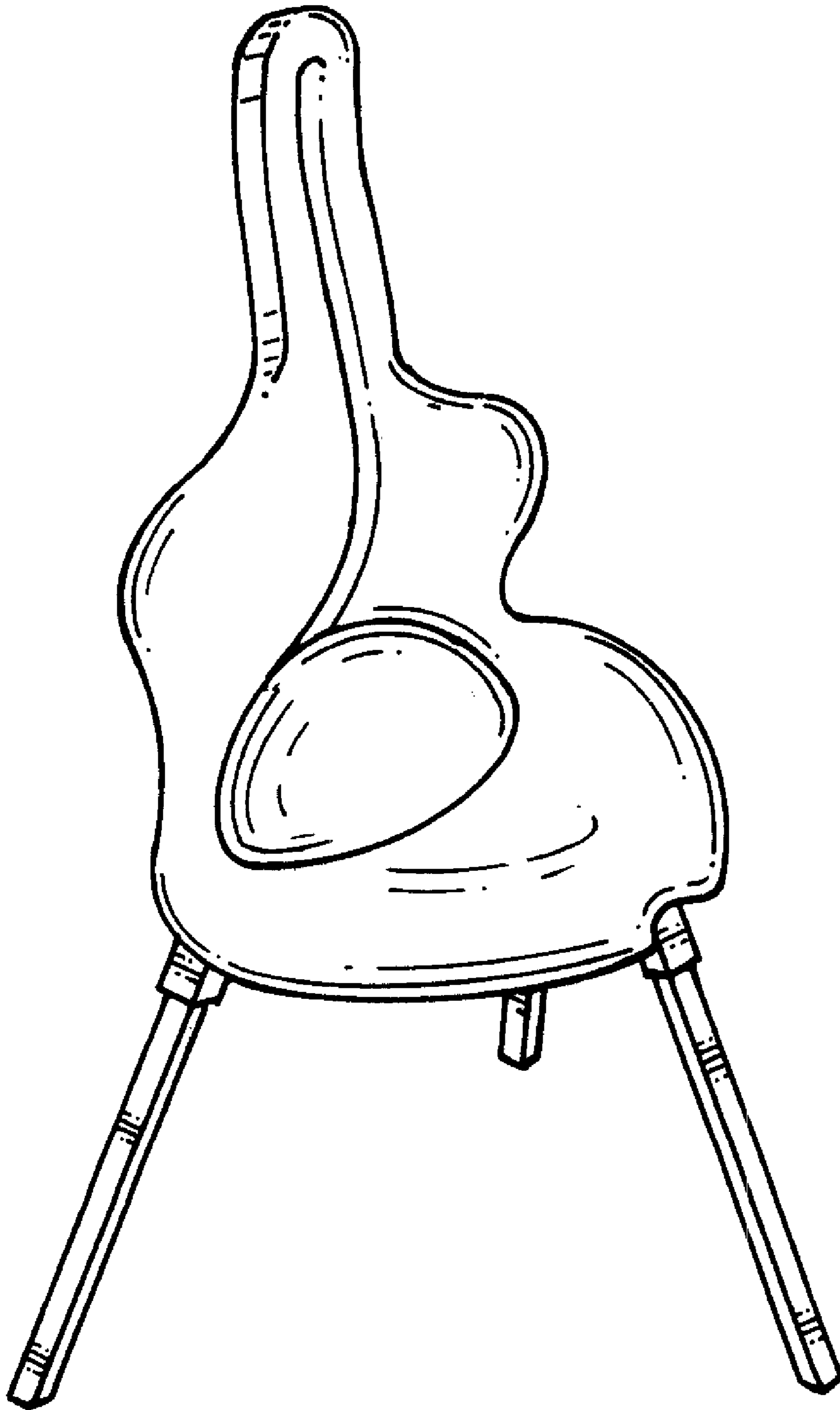

FIG. 1.

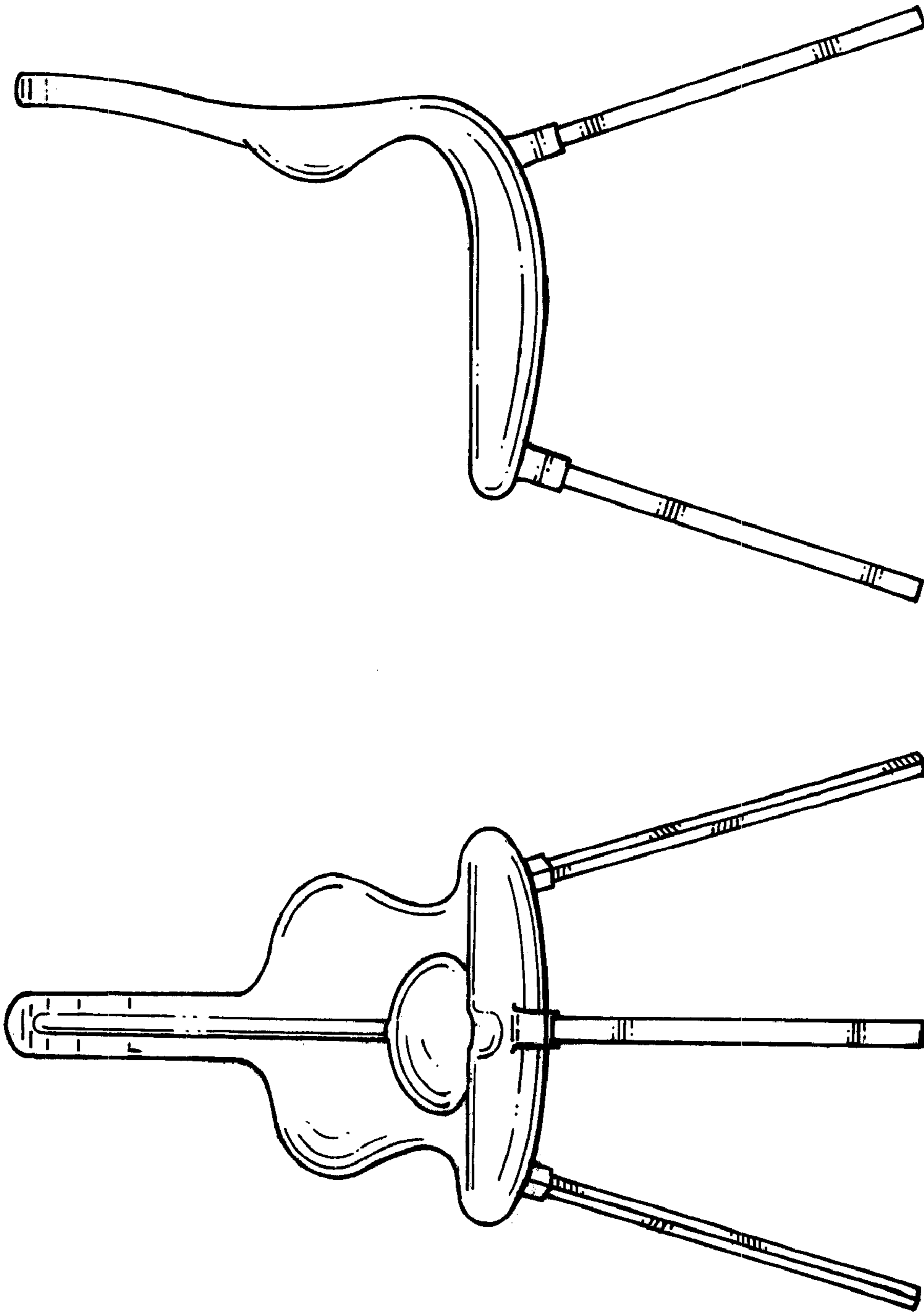

FIG. 4

FIG. 2.

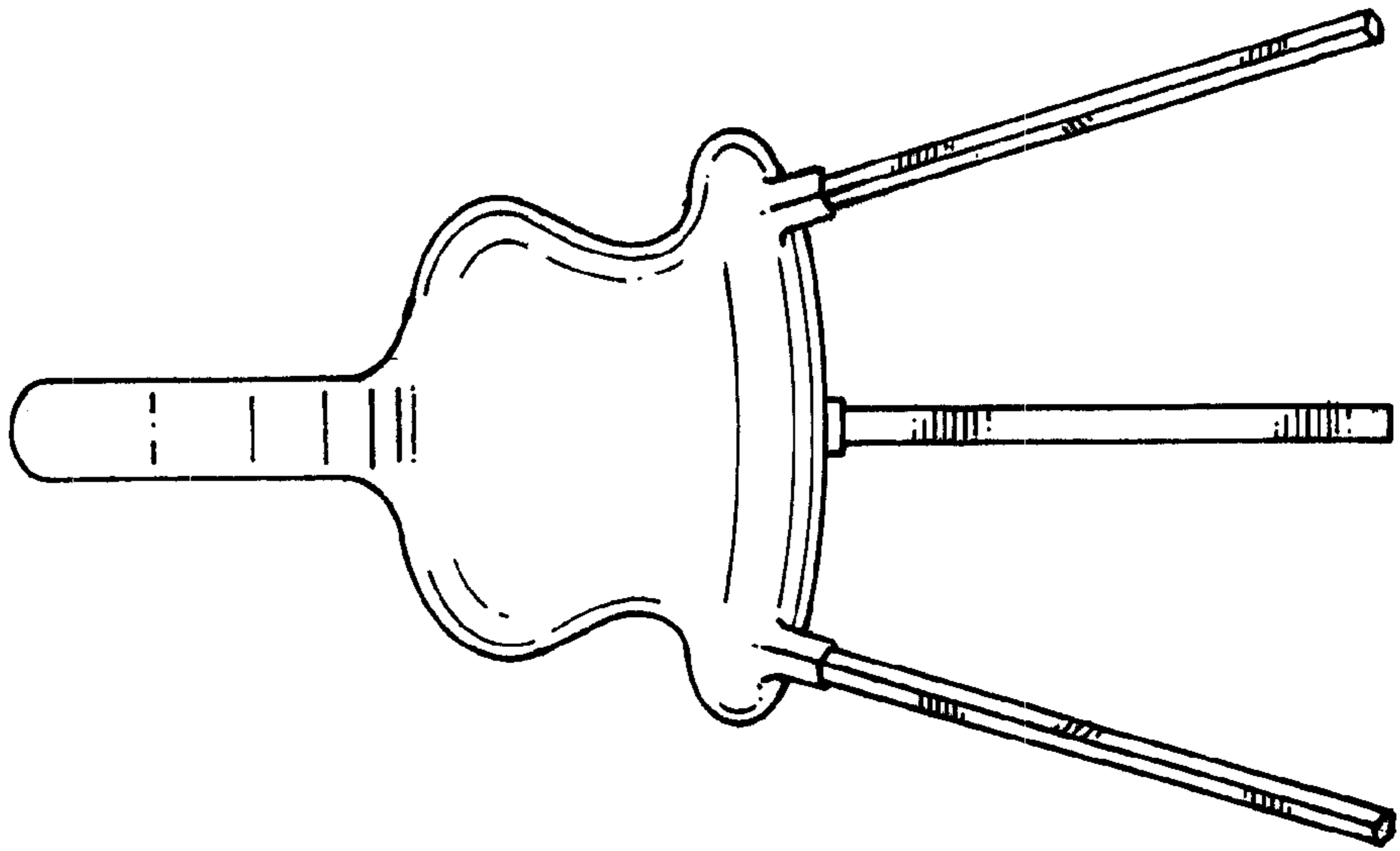

FIG. 3.

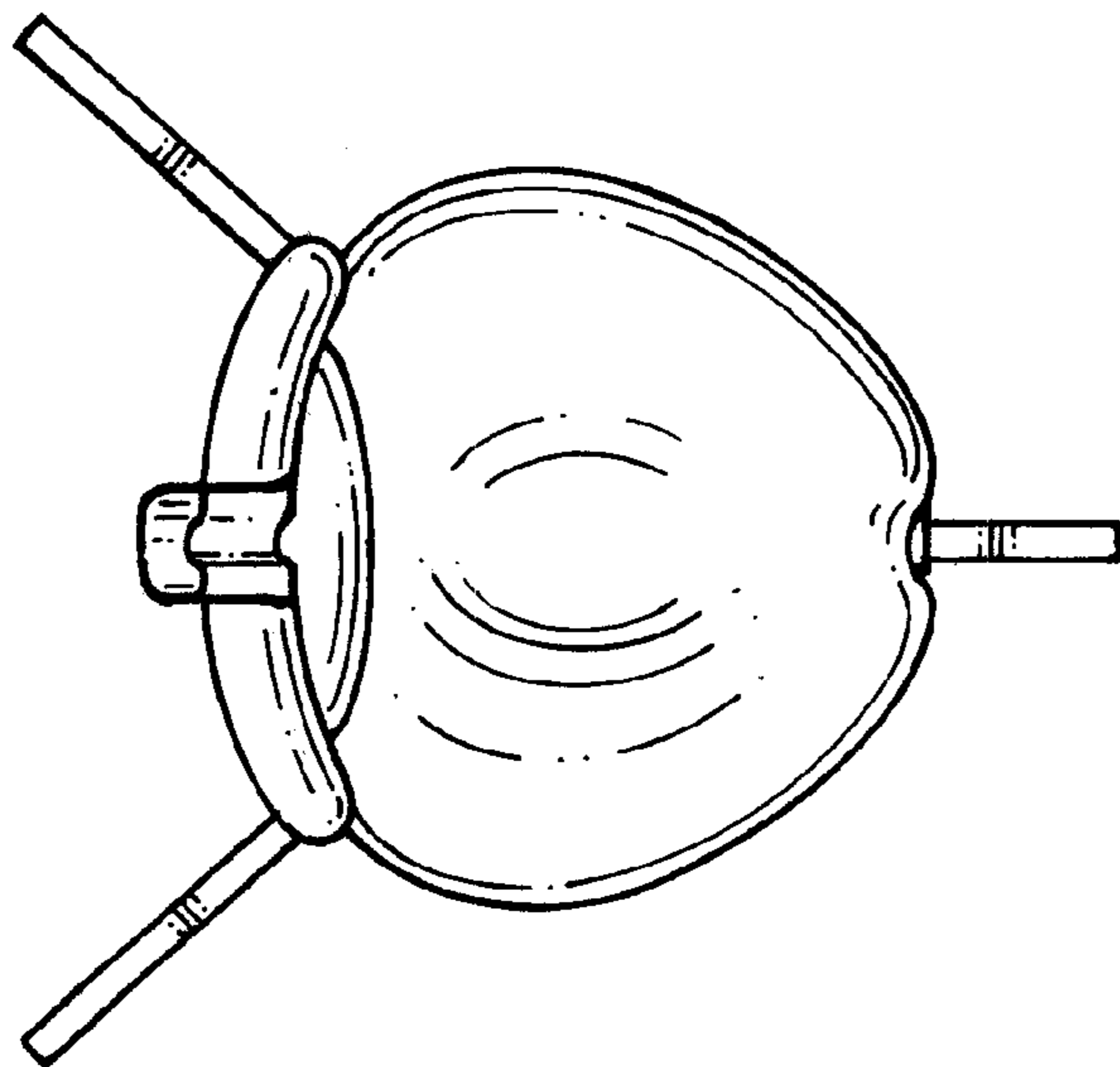

FIG. 5.

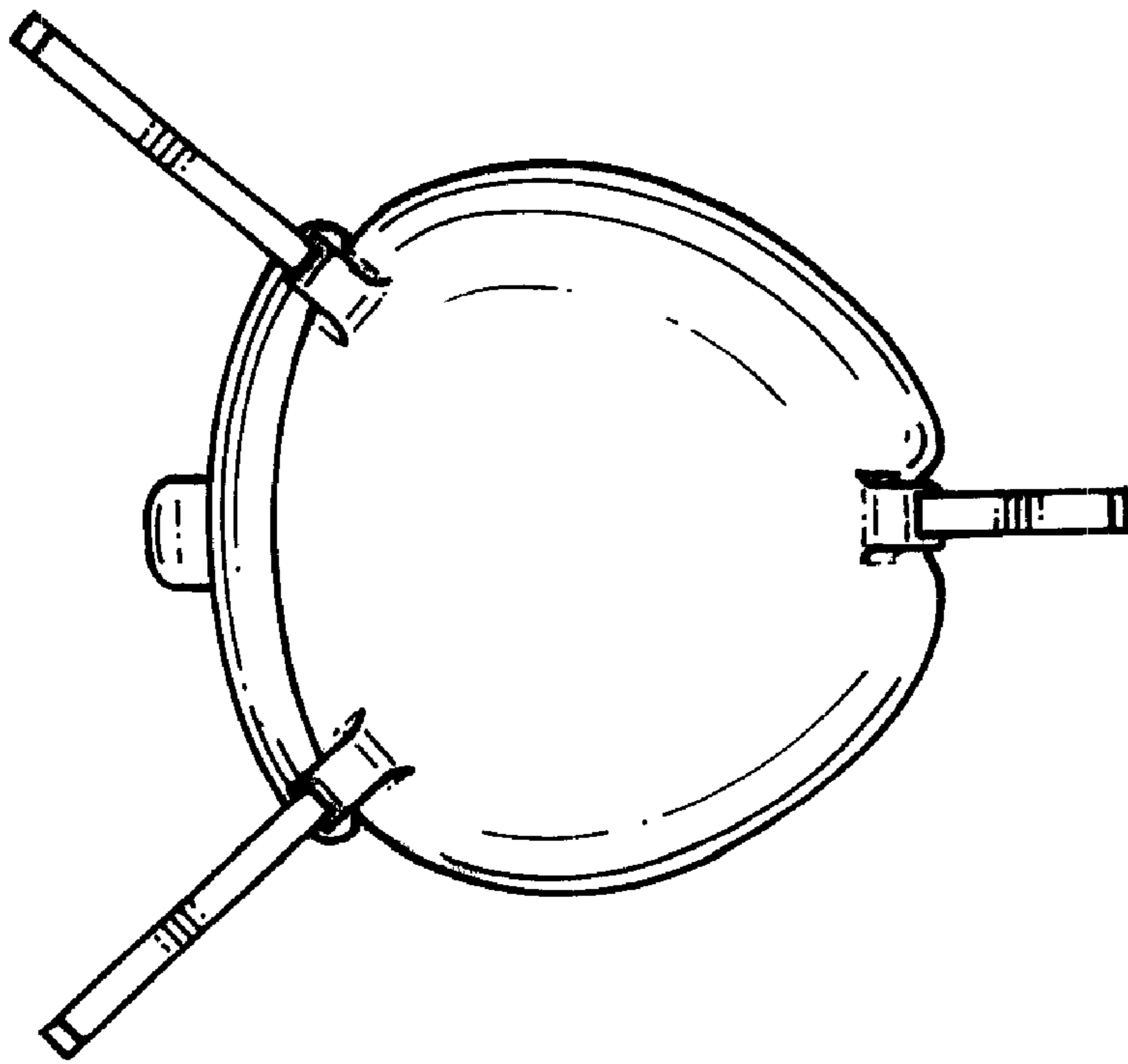

FIG. 6.