



US00D460721S

(12) **United States Design Patent**
Rex

(10) **Patent No.:** **US D460,721 S**

(45) **Date of Patent:** **** Jul. 23, 2002**

(54) **RECREATIONAL VEHICLE**

(75) **Inventor:** **William J. Rex**, Canyon Country, CA (US)

(73) **Assignee:** **Rexhall Industries, Inc.**, Lancaster, CA (US)

(**) **Term:** **14 Years**

(21) **Appl. No.:** **29/148,259**

(22) **Filed:** **Sep. 18, 2001**

(51) **LOC (7) Cl.** **12-08**

(52) **U.S. Cl.** **D12/100**

(58) **Field of Search** D12/100, 99, 84;
296/185, 156, 164, 166

(56) **References Cited**

U.S. PATENT DOCUMENTS

D323,476 S	*	1/1992	Shea, Sr.	D12/100
D338,432 S	*	8/1993	Slayter	D12/100
D376,562 S	*	12/1996	Sealy et al.	D12/84
D449,797 S	*	10/2001	Gerzeny et al.	D12/103

* cited by examiner

Primary Examiner—Melody N. Brown

(74) *Attorney, Agent, or Firm*—Stetina Brunda Garred & Brucker

(57) **CLAIM**

The ornamental design for a recreational vehicle, as shown and described.

DESCRIPTION

FIG. 1 is a top, front perspective view of the recreational vehicle of the present invention showing my new design;

FIG. 2 is a top, rear perspective view thereof;

FIG. 3 is a top plan view thereof; and

FIG. 4 is a left side elevational view thereof, the right side elevational view being a mirror image of the left side elevational view;

FIG. 5 is a front elevational view thereof; and,

FIG. 6 is a rear elevational view thereof.

The broken lines are shown for illustrative purposes only and form no part of the claimed design.

1 Claim, 3 Drawing Sheets

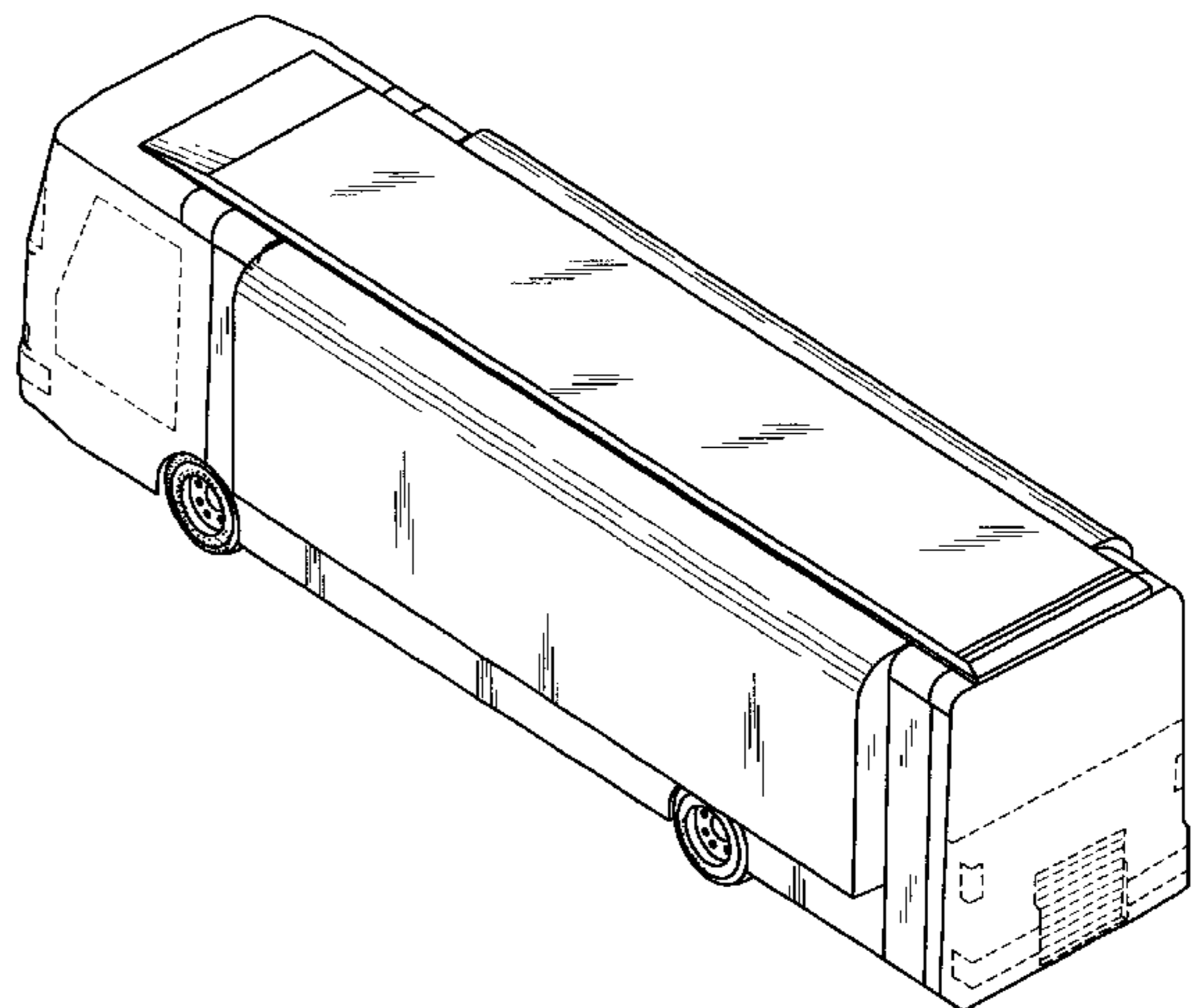
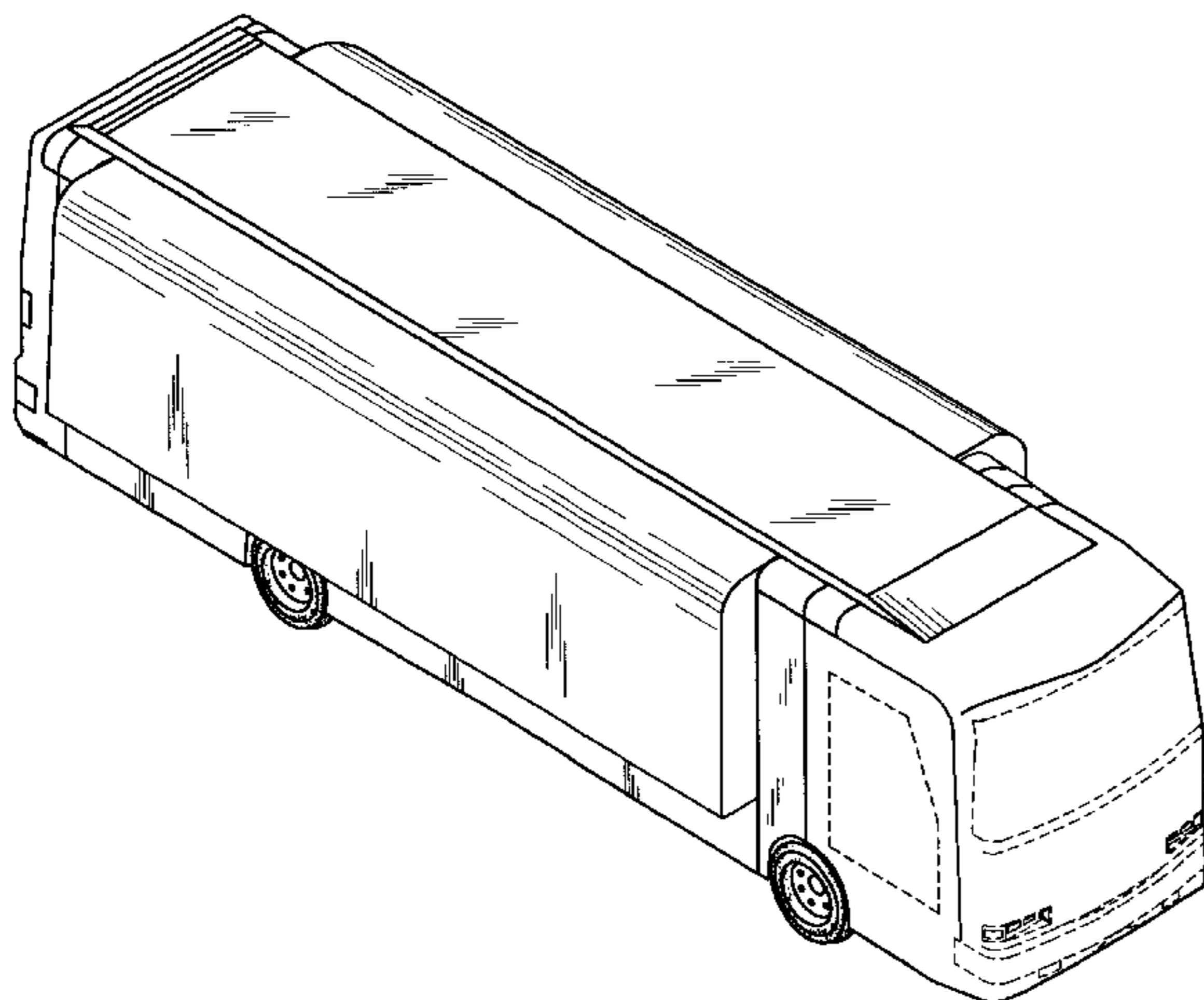

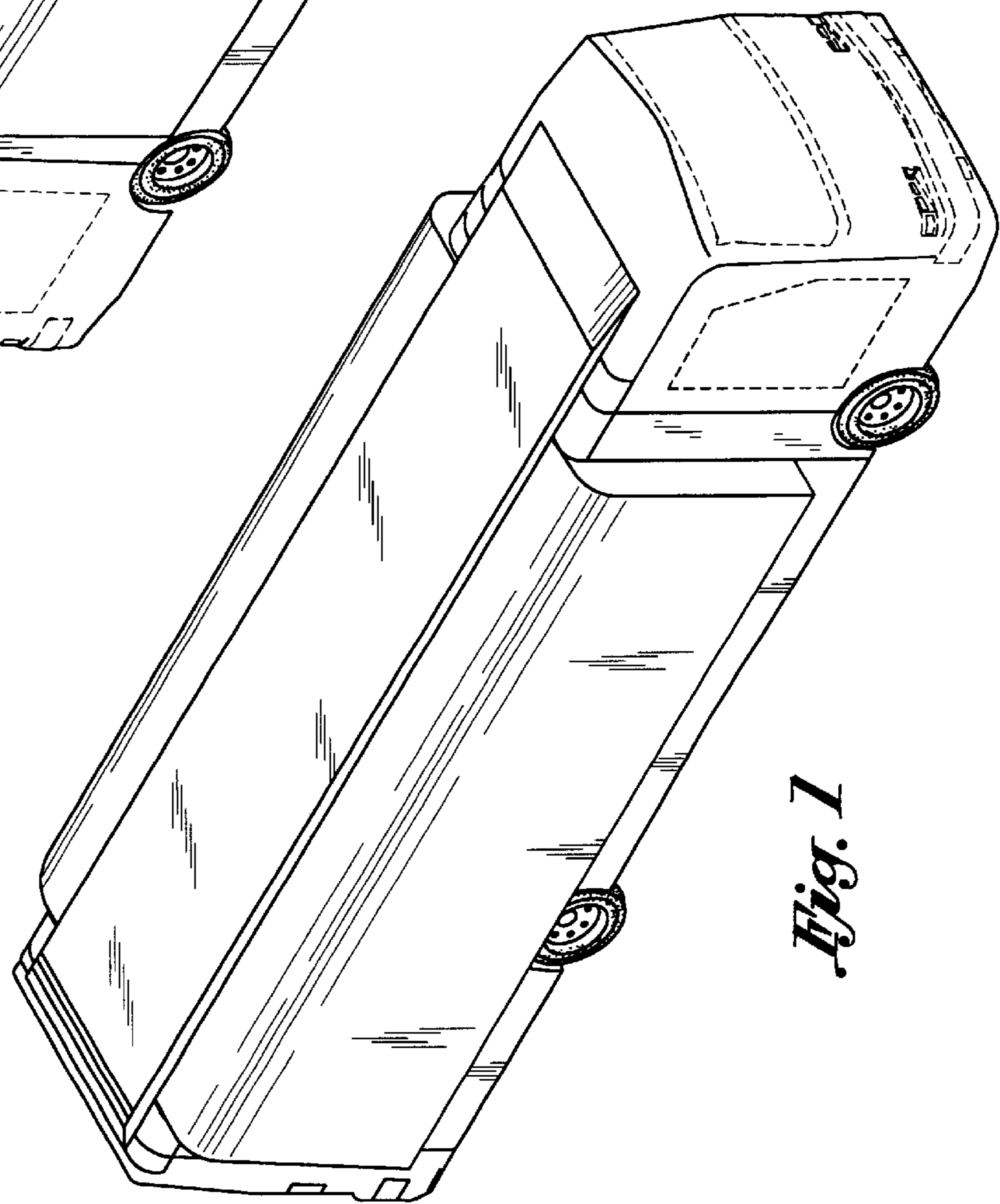
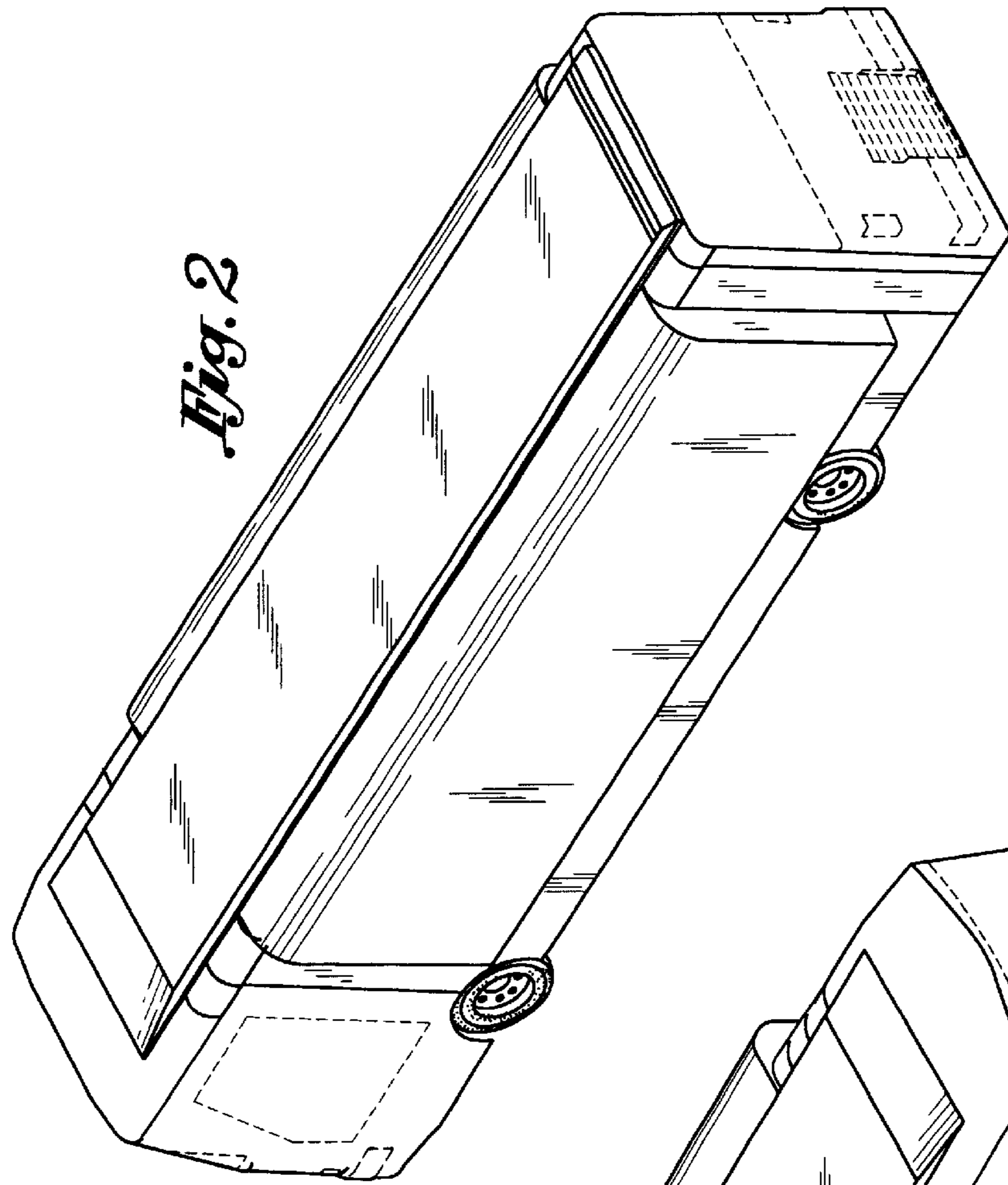

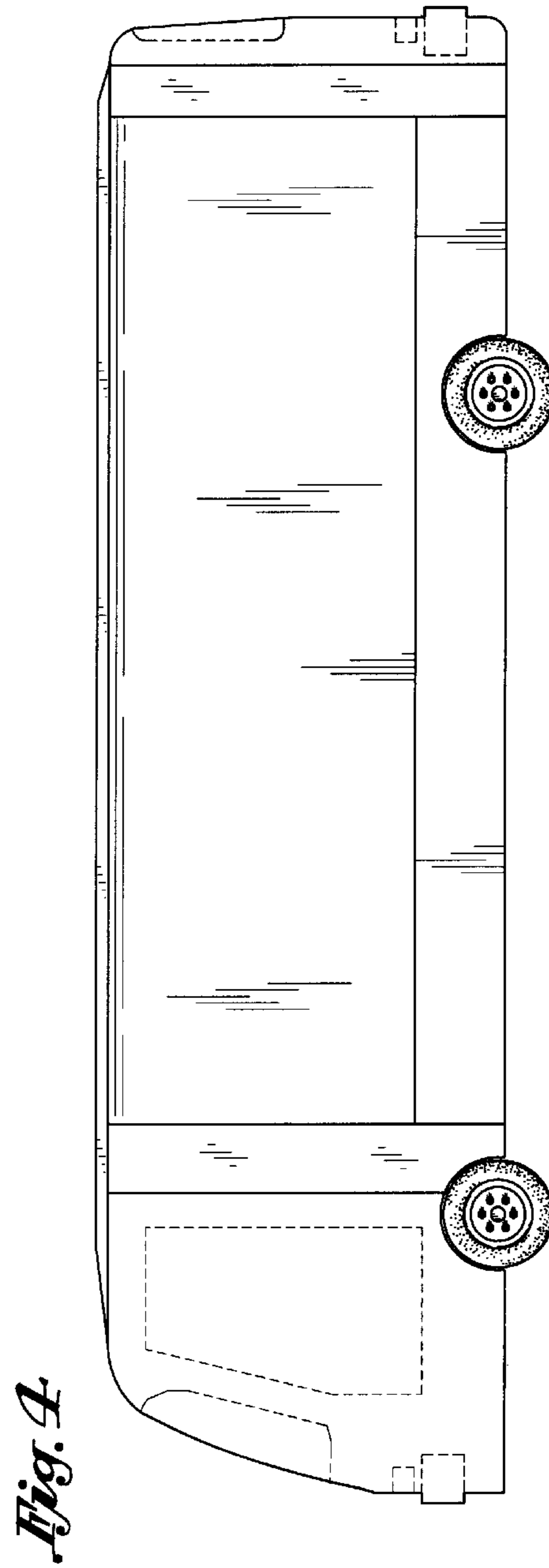
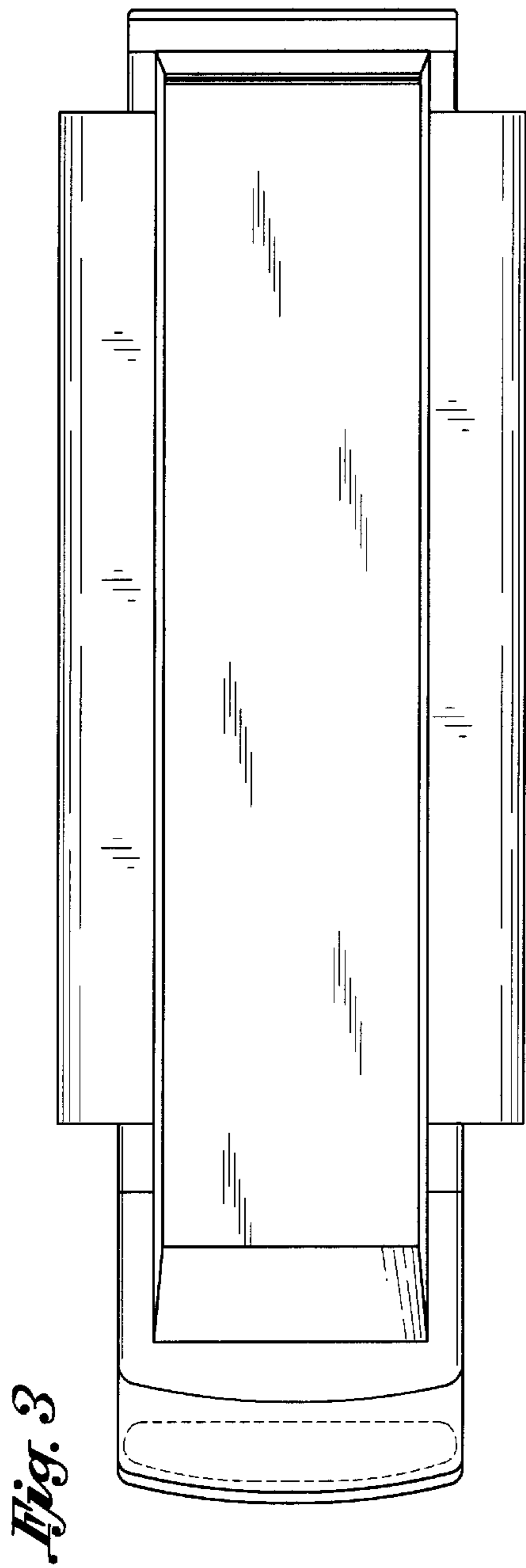

Fig. 6

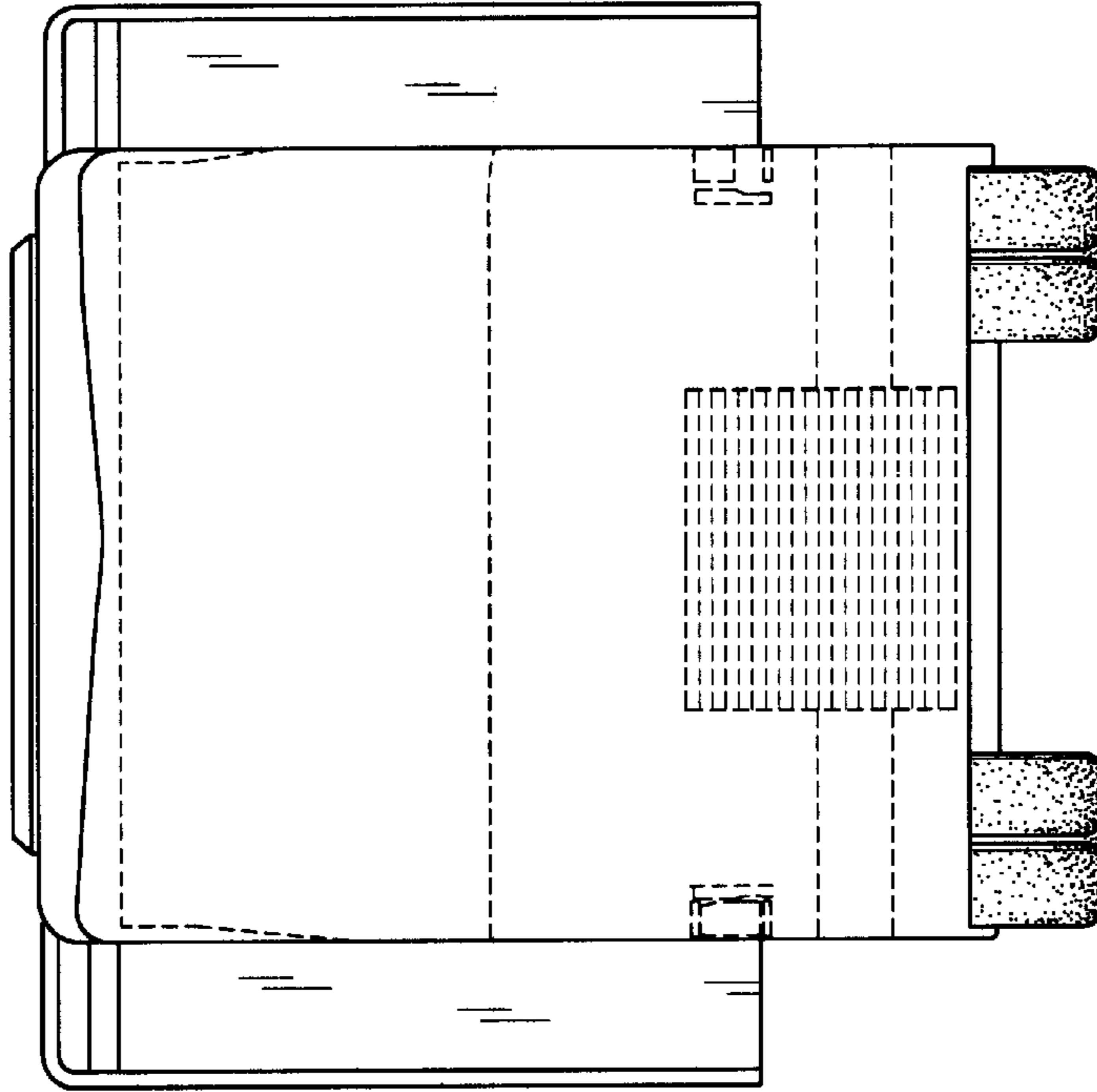

Fig. 5

