



US00D460148S

(12) **United States Design Patent**
Hayashi et al.

(10) **Patent No.:** **US D460,148 S**

(45) **Date of Patent:** **** Jul. 9, 2002**

(54) **SOLENOID-DRIVEN PILOT VALVE**

D443,030 S * 5/2001 Kaneko et al. D23/233

* cited by examiner

(75) Inventors: **Bunya Hayashi; Jiro Karasaki**, both of Ibaraki (JP)

Primary Examiner—Nelson C. Holtje

(73) Assignee: **SMC Corporation**, Tokyo (JP)

(74) *Attorney, Agent, or Firm*—Oblon, Spivak, McClelland, Maier & Neustadt, P.C.

(**) Term: **14 Years**

(57) **CLAIM**

(21) Appl. No.: **29/142,144**

The ornamental design for a solenoid-driven pilot valve, as shown and described.

(22) Filed: **May 21, 2001**

DESCRIPTION

(30) **Foreign Application Priority Data**

FIG. 1 is a front elevational view of the solenoid-driven pilot valve showing our new design;

Nov. 20, 2000 (JP) 2000-036957

FIG. 2 is a rear elevational view thereof;

(51) **LOC (7) Cl.** **23-01**

FIG. 3 is a right side elevational view thereof;

(52) **U.S. Cl.** **D23/233**

FIG. 4 is a left side elevational view thereof;

(58) **Field of Search** D23/233; 137/884,
137/625.64; 251/129.15

FIG. 5 is a top plan view thereof;

FIG. 6 is a bottom plan view thereof;

(56) **References Cited**

FIG. 7 is a top, front and right side perspective view thereof; and,

U.S. PATENT DOCUMENTS

FIG. 8 is a rear, bottom and left side perspective view thereof.

D300,172 S * 3/1989 Martin D23/235

The broken line showings of indicia are environmental only and form no part of the claimed design.

D312,122 S * 11/1990 Veillette D23/249

D409,279 S * 5/1999 Hayashi et al. D23/233

1 Claim, 4 Drawing Sheets

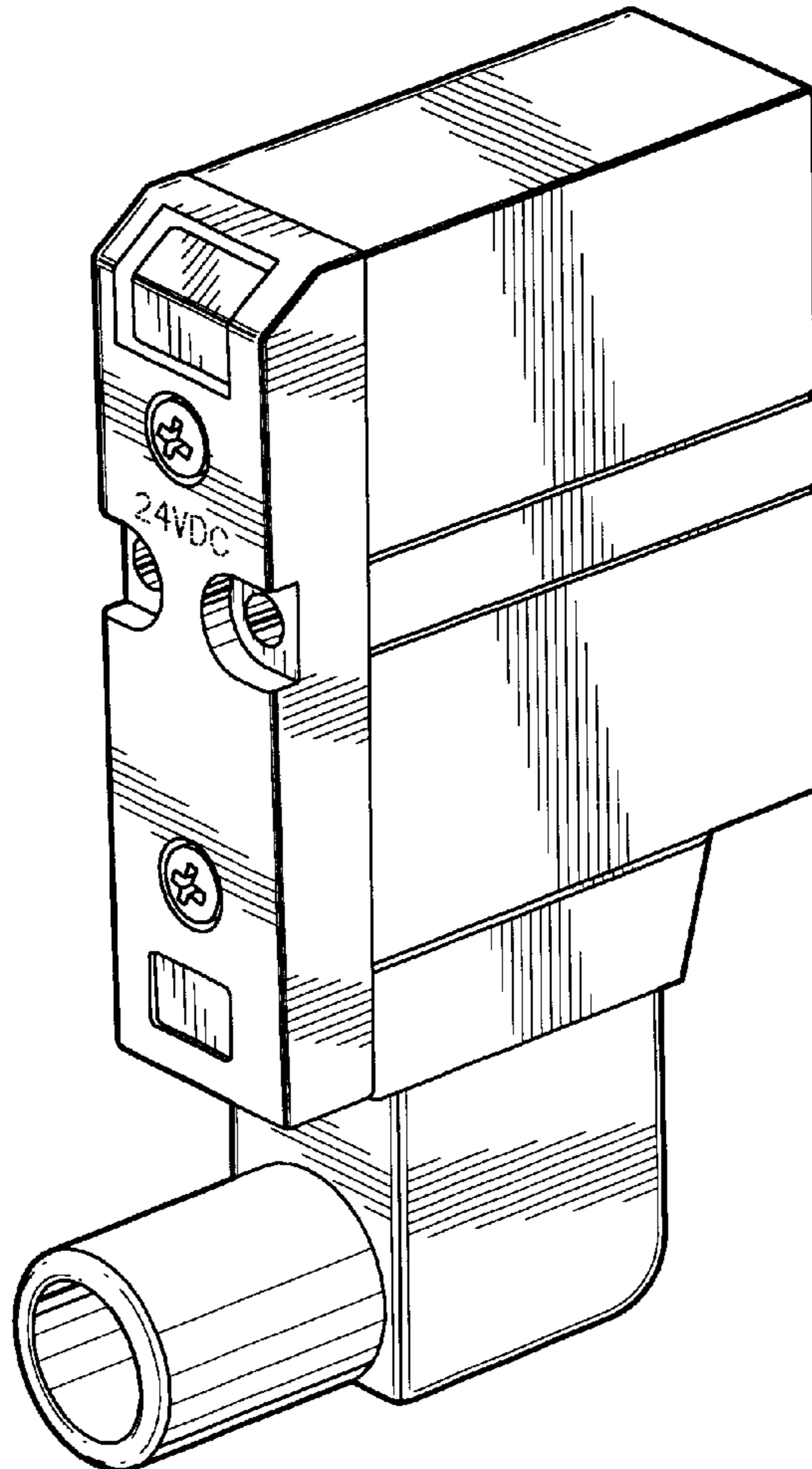

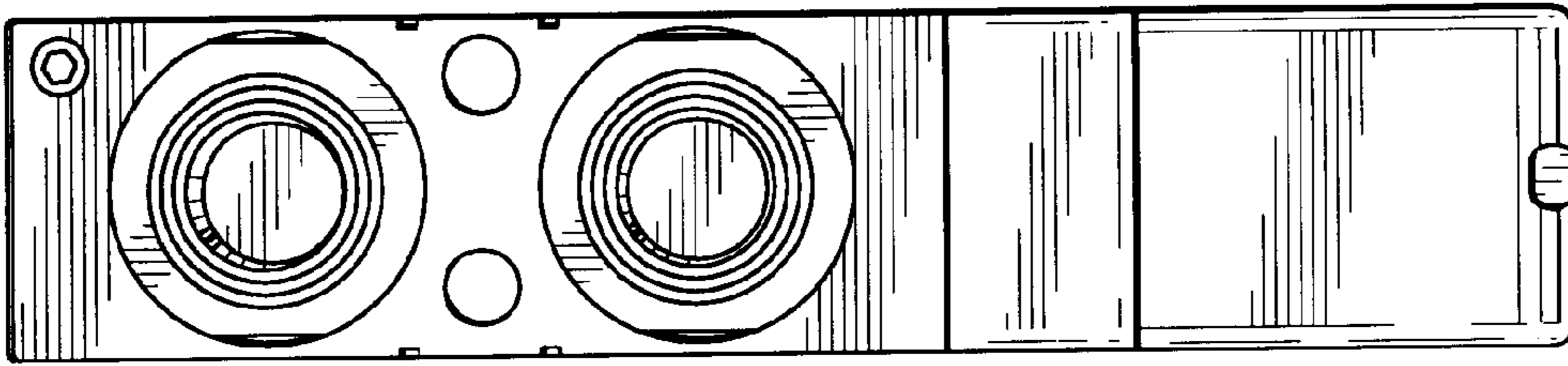

FIG. 2

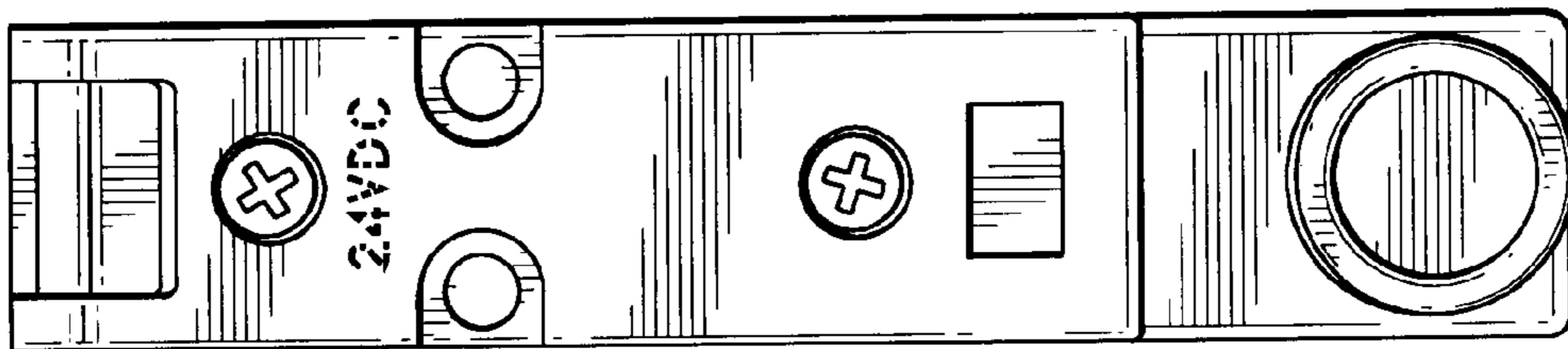

FIG. 1

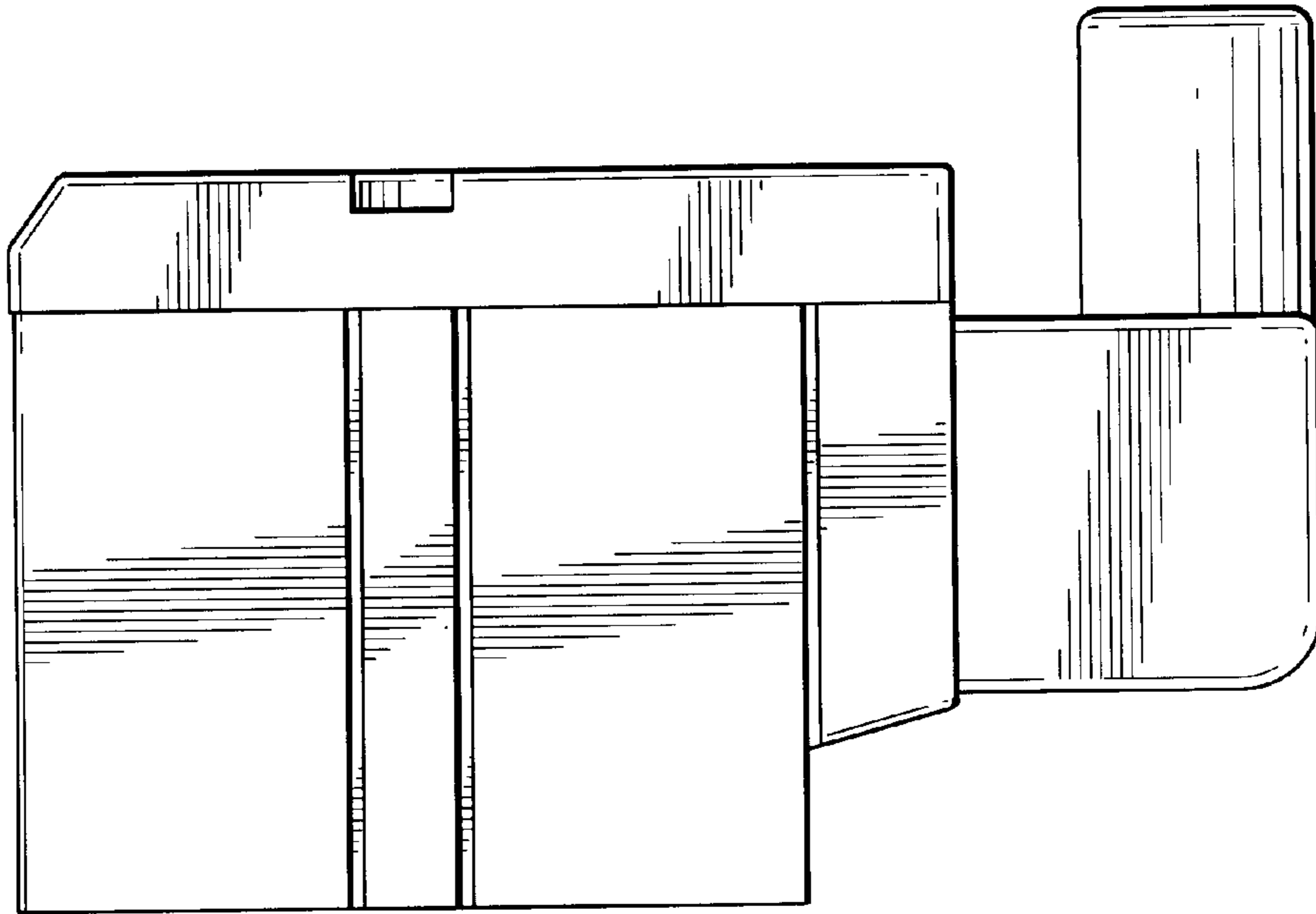

FIG. 4

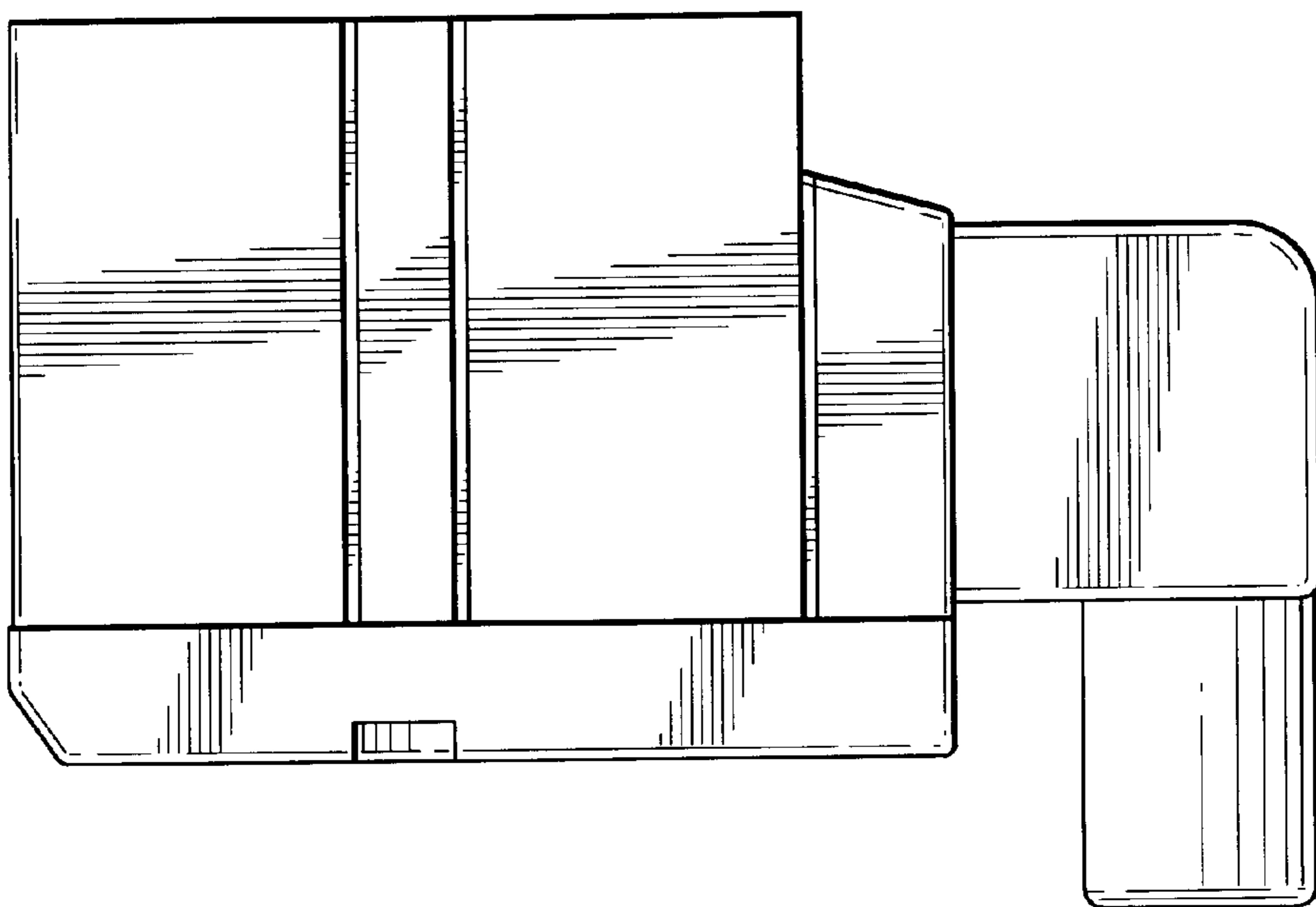

FIG. 3

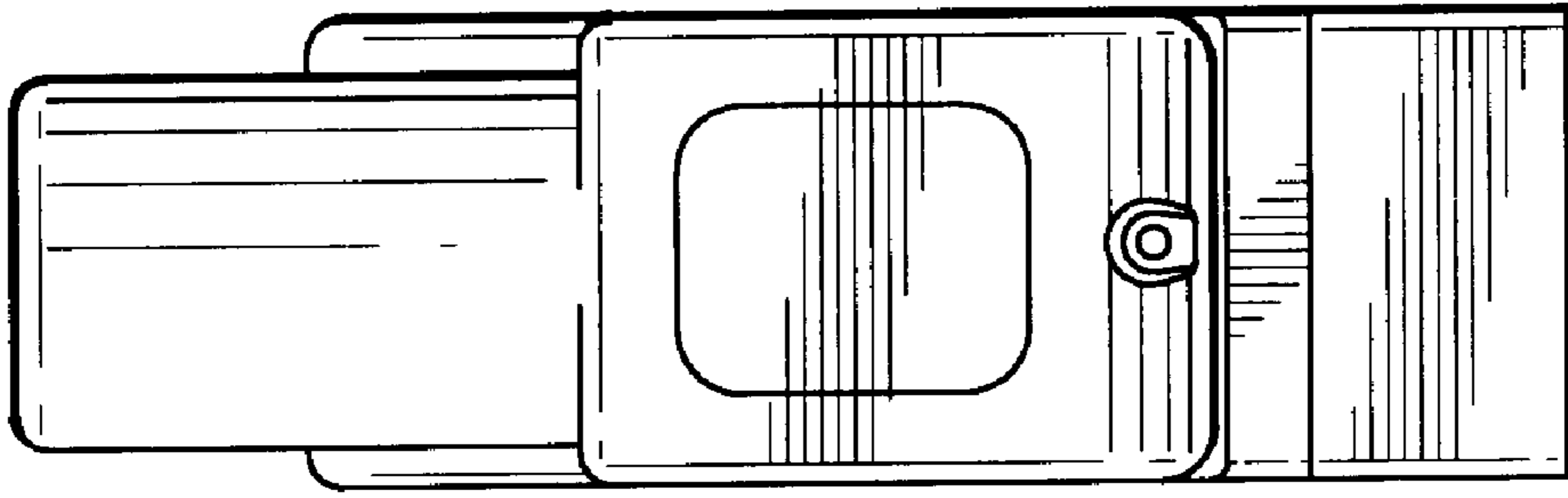

FIG. 6

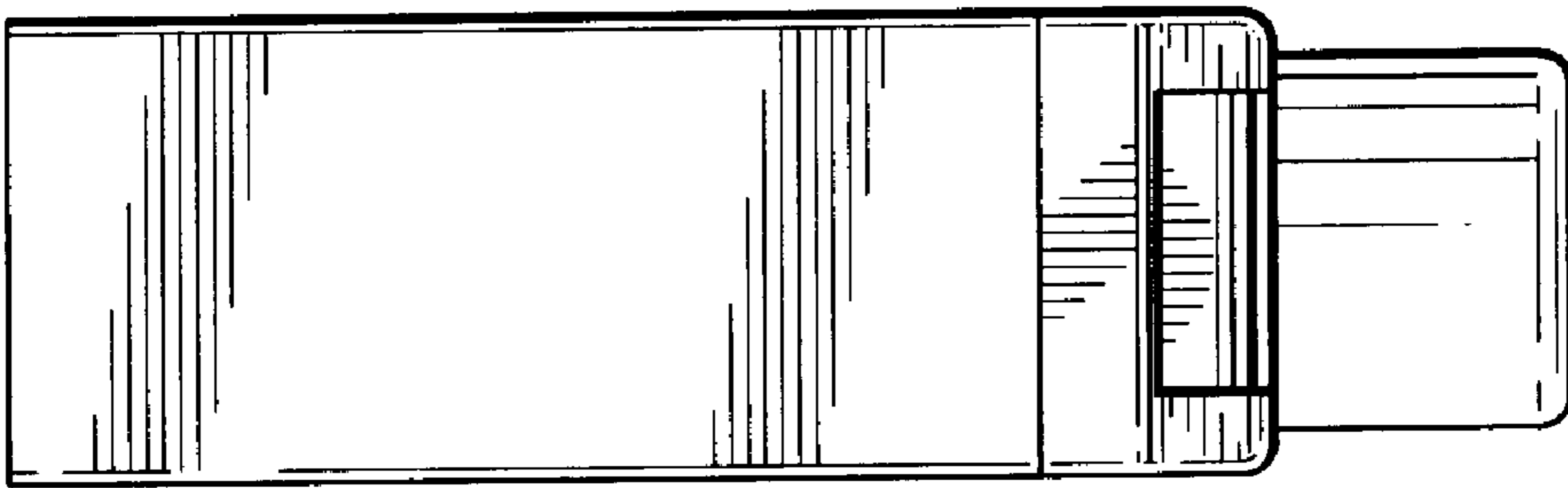

FIG. 5

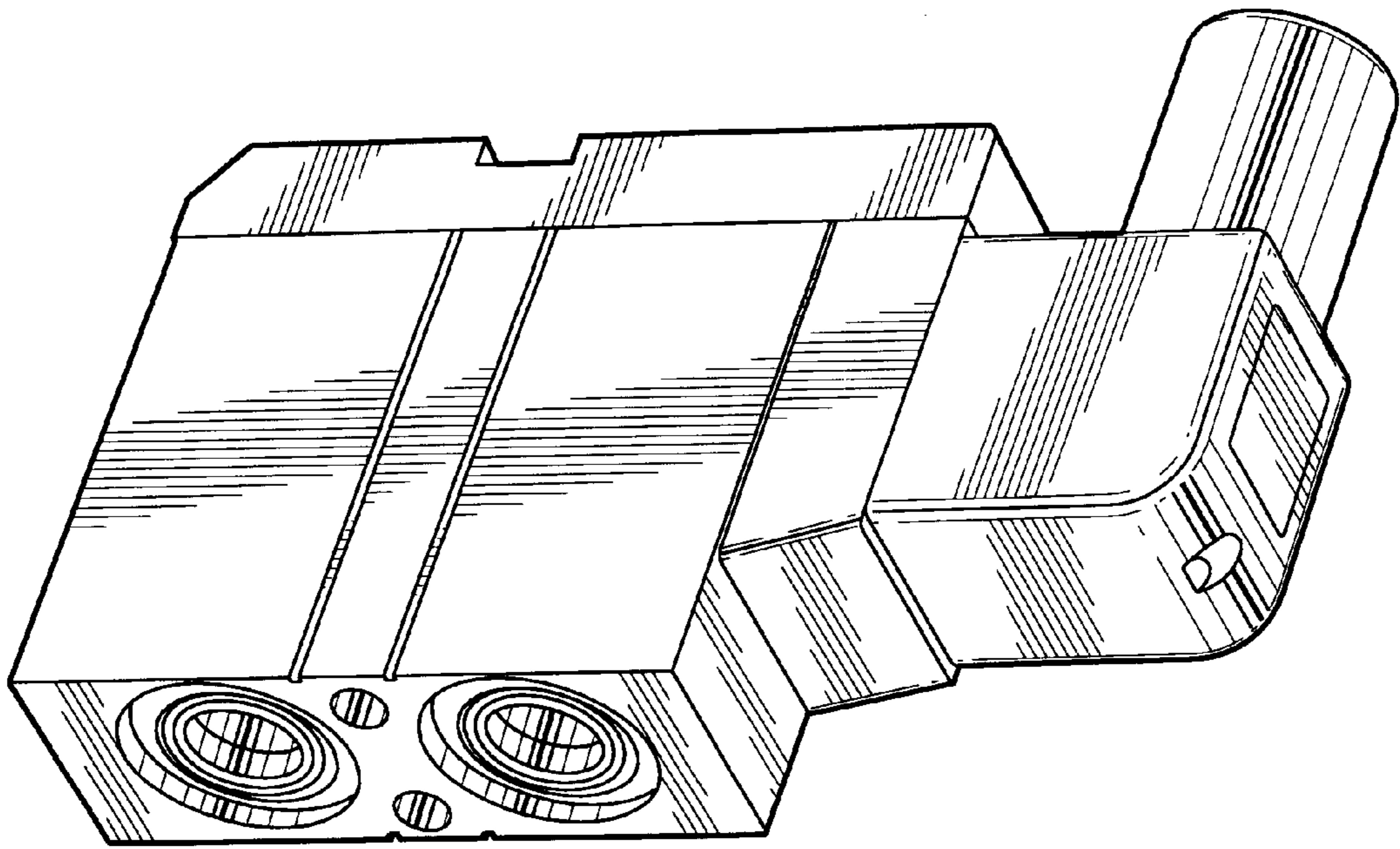

FIG. 8

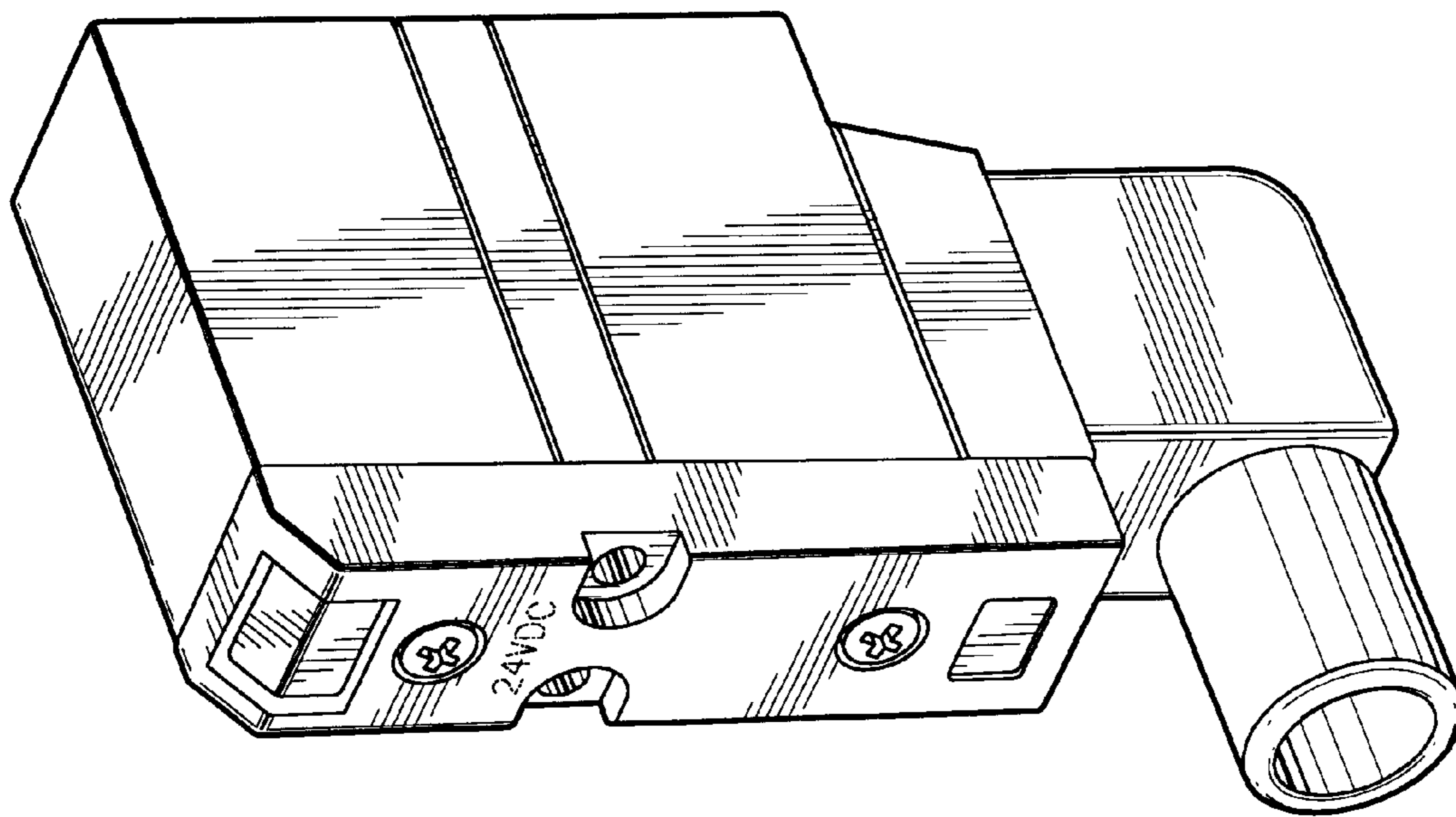

FIG. 7