



US00D460092S

(12) **United States Design Patent**
Gressett, Jr. et al.

(10) **Patent No.:** **US D460,092 S**
(45) **Date of Patent:** **** Jul. 9, 2002**

(54) **DISCHARGE PORTION OF A LIQUID FILAMENT DISPENSING VALVE**

D354,296 S * 1/1995 Walsh D15/144.1
D365,830 S * 1/1996 Hubbard et al. D15/144.2
6,056,155 A 5/2000 Byerly et al. 222/1

(75) Inventors: **Charles A. Gressett, Jr.**, Norcross;
David E. Hardy, Duluth; **John M. Riney**, Buford; **Laurence B. Saidman**, Duluth; **Paul Schmidt**, Sugar Hill, all of GA (US)

* cited by examiner

Primary Examiner—Antoine Duval Davis
(74) *Attorney, Agent, or Firm*—Wood, Herron & Evans, L.L.P.

(73) Assignee: **Nordson Corporation**, Westlake, OH (US)

(57) **CLAIM**

(**) Term: **14 Years**

The ornamental design for a discharge portion of a liquid filament dispensing valve, as shown and described.

(21) Appl. No.: **29/150,970**

DESCRIPTION

(22) Filed: **Oct. 31, 2001**

FIG. 1 is a bottom perspective view of the discharge portion of a liquid filament dispensing valve;
FIG. 2 is a front view of FIG. 1;
FIG. 3 is a right side view of FIG. 1;
FIG. 4 is a left side view of FIG. 1;
FIG. 5 is a top view of FIG. 1; and,
FIG. 6 is a bottom view of FIG. 1.

(51) **LOC (7) Cl.** **15-09**

(52) **U.S. Cl.** **D15/144.1**

(58) **Field of Search** D15/144, 144.1,
D15/144.2; 118/302, 313, 323, 697; 222/1,
146.5, 189, 482, 504; 239/415; 427/286,
288.2; 901/143

The elements shown in dash-dot lines form no part of the claimed invention, and are instead included to show environmental aspects of the claimed invention.

(56) **References Cited**

U.S. PATENT DOCUMENTS

D354,295 S * 1/1995 Walsh et al. D15/144.1

1 Claim, 3 Drawing Sheets

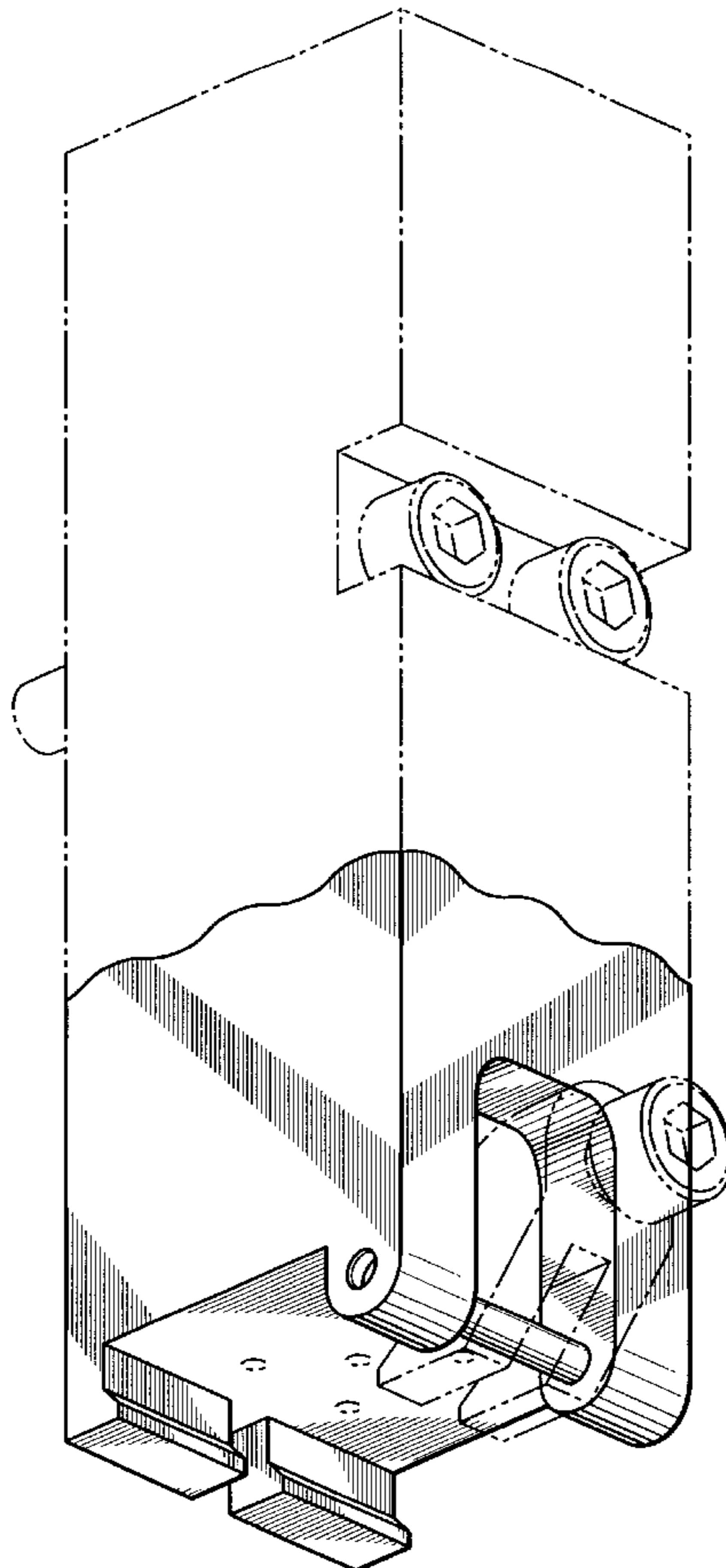

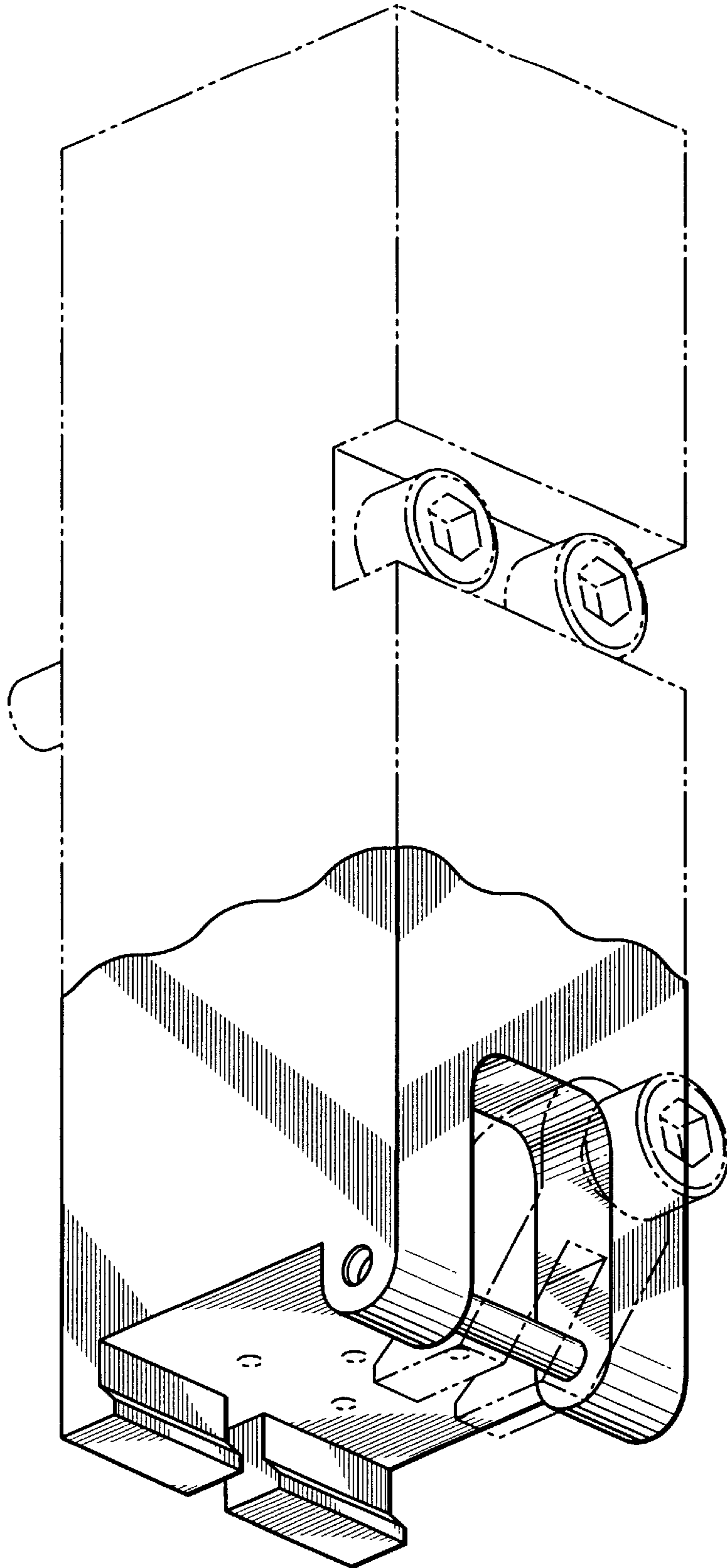
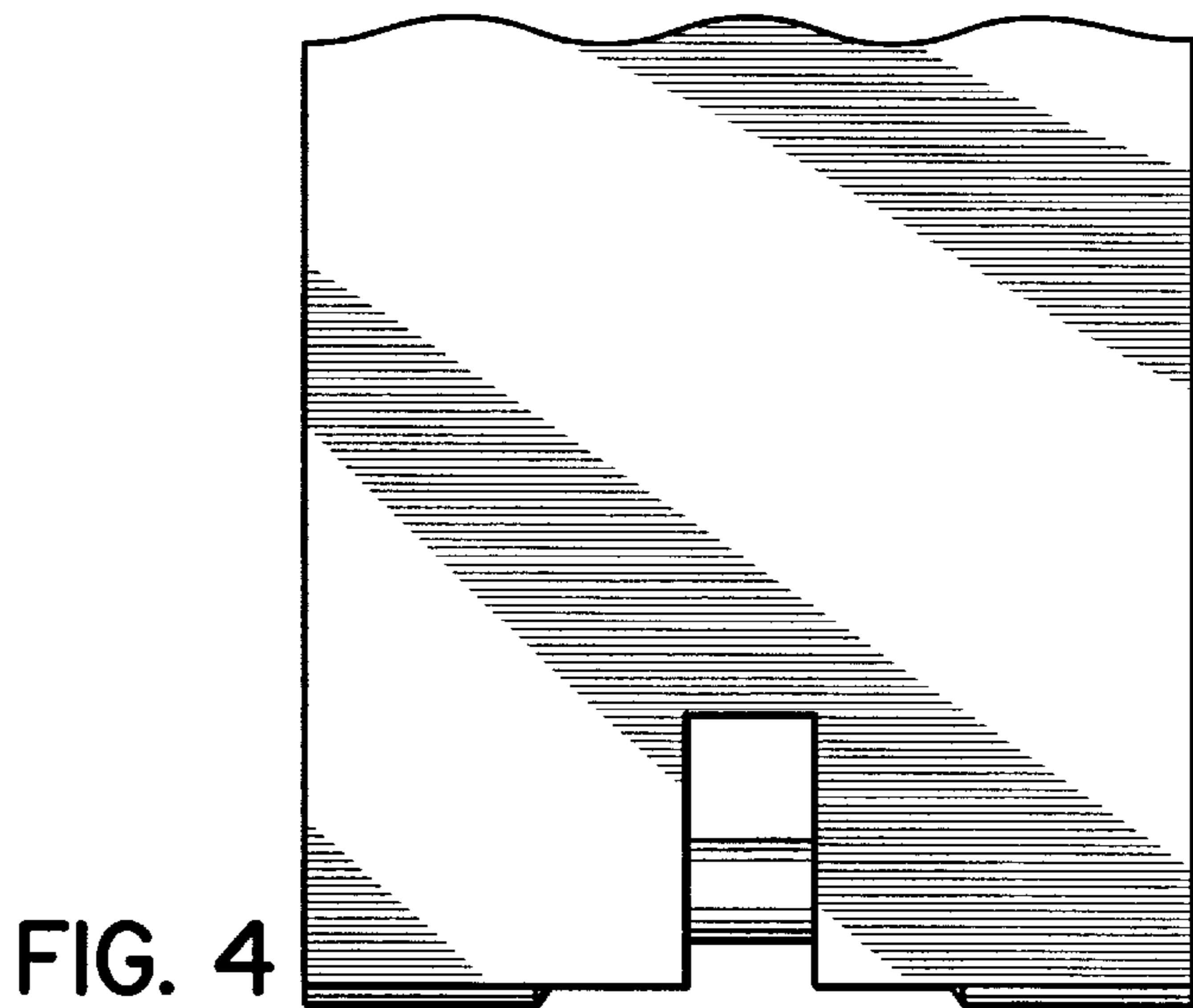
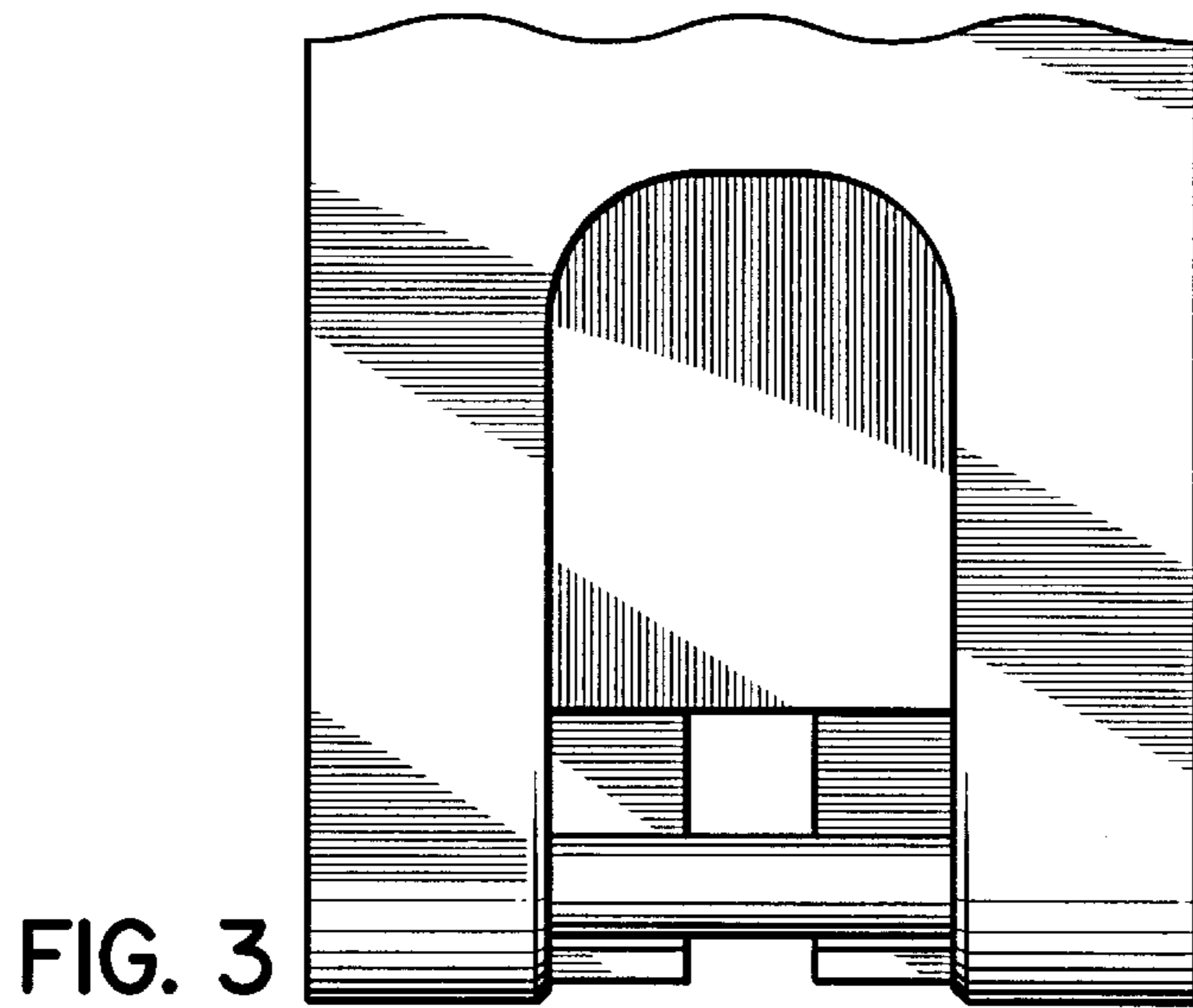
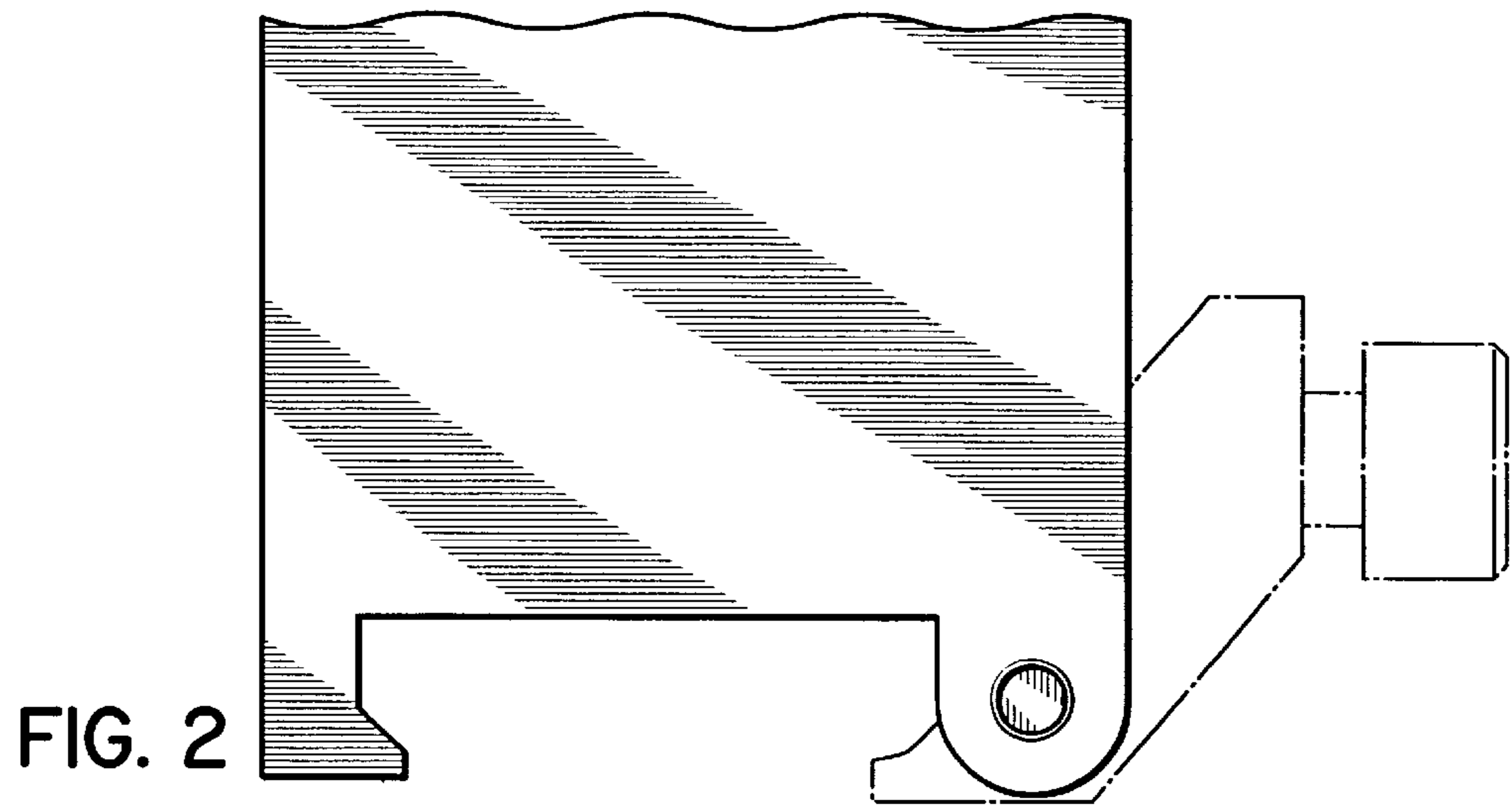

FIG. 1



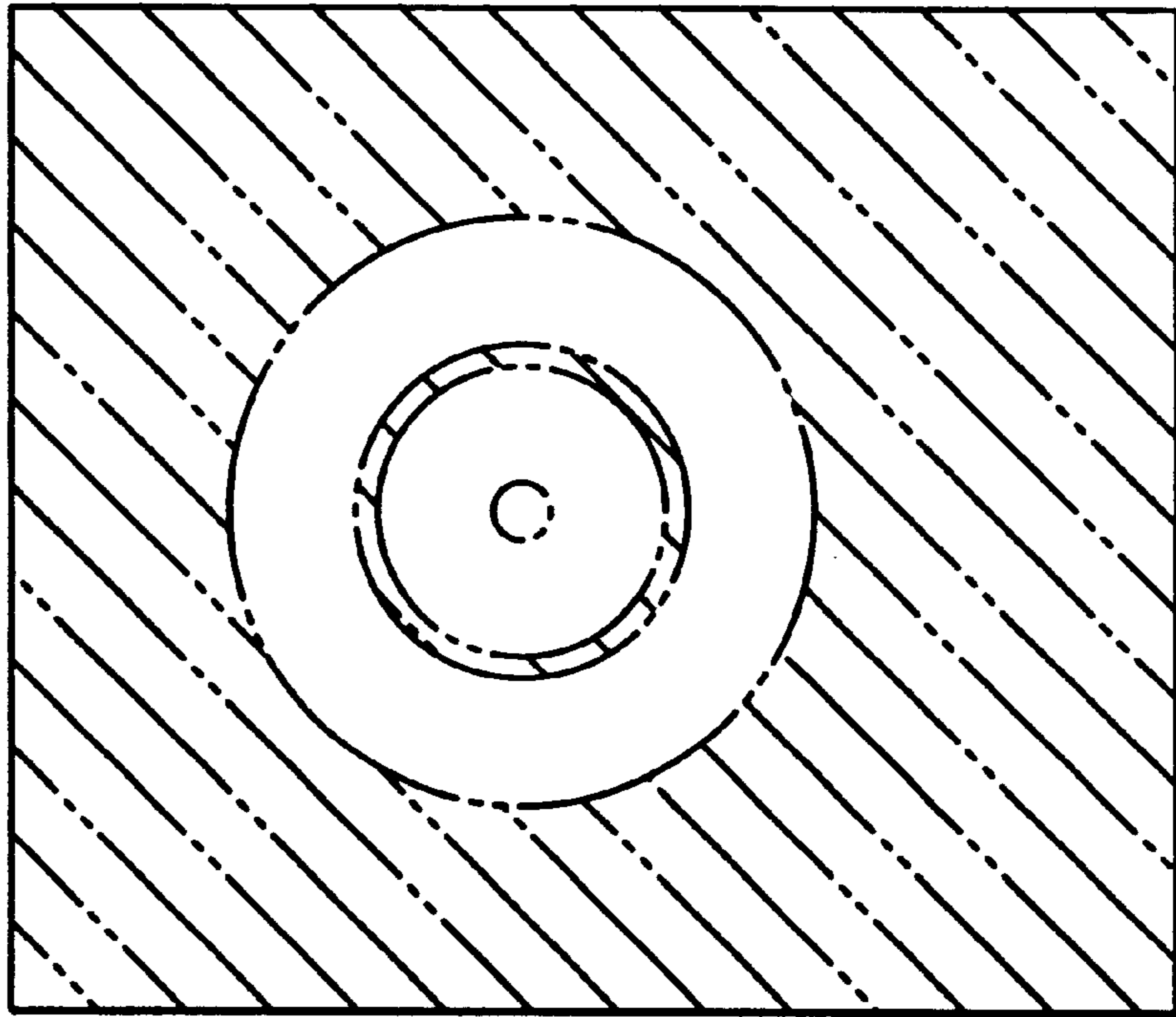

FIG. 5

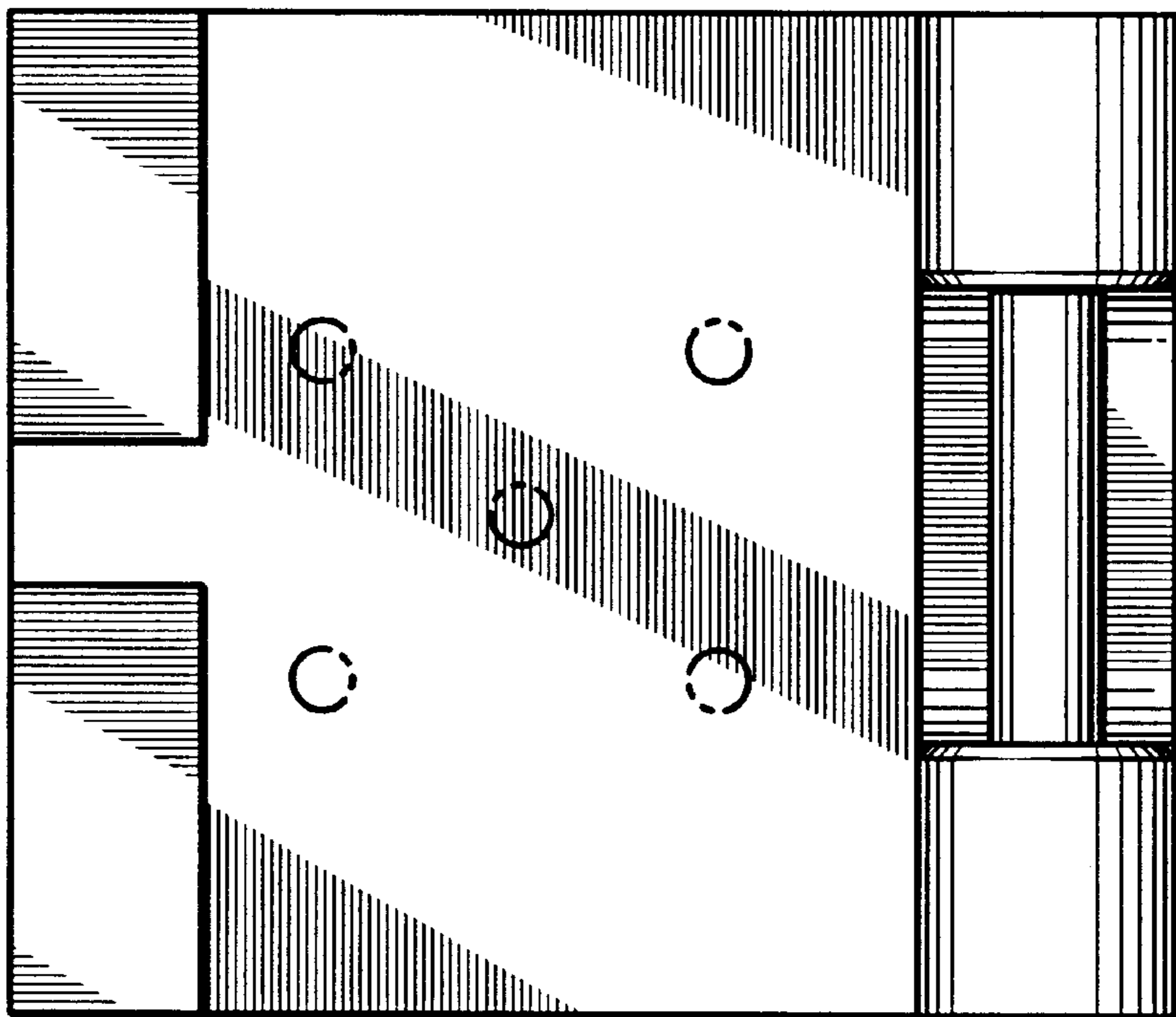

FIG. 6