



US00D460030S

(12) **United States Design Patent**
Duckett et al.

(10) **Patent No.:** **US D460,030 S**

(45) **Date of Patent:** **** Jul. 9, 2002**

(54) **VEHICLE FRONT BUMPER**

(75) Inventors: **Karl I. Duckett; Ruben Perfetti**, both of Greensboro, NC (US)

(73) Assignee: **Volvo Trucks North America, Inc.**, Greensboro, NC (US)

(**) Term: **14 Years**

(21) Appl. No.: **29/145,239**

(22) Filed: **Jul. 18, 2001**

(51) **LOC (7) Cl.** **12-16**

(52) **U.S. Cl.** **D12/169**

(58) **Field of Search** D12/169, 196;
293/102, 113, 115, 117, 120; 296/180.1,
180.2

(56) **References Cited**

U.S. PATENT DOCUMENTS

D248,156 S	6/1978	Tixier	
D280,497 S	9/1985	Sullivan et al.	
D300,128 S	3/1989	Brennan	
D318,835 S	8/1991	Partin	
5,141,068 A	8/1992	Mendicino	
D343,605 S	1/1994	Meryman	
5,462,325 A	10/1995	Masuda et al.	
D372,695 S	8/1996	Nagashima	
D391,212 S	2/1998	Meryman et al.	
D400,143 S	10/1998	Walters et al.	
D400,144 S	10/1998	Hellhake et al.	
D403,636 S	1/1999	Meryman et al.	
5,860,685 A	1/1999	Horney et al.	
D410,220 S	5/1999	Mobius et al.	
D417,641 S	12/1999	Saleen	
D418,464 S	1/2000	Saleen et al.	
D429,669 S	8/2000	Cook et al.	
D448,330 S	* 9/2001	Tampi	D12/169
D452,206 S	* 12/2001	Fuji et al.	D12/169

* cited by examiner

Primary Examiner—Melody N. Brown

(74) *Attorney, Agent, or Firm*—Watts, Hoffmann, Fisher & Heinke Co., L.P.A.

(57) **CLAIM**

We claim the ornamental design for a vehicle front bumper, as shown and described.

DESCRIPTION

FIG. 1 is a perspective view of a vehicle front bumper of an over the highway heavy duty vehicle designed primarily for use in an axle back vehicle;

FIG. 2 is a top plan view of the bumper of FIG. 1;

FIG. 3 is a front elevational view of the bumper of FIG. 1;

FIG. 4 is a right side, as viewed in FIG. 3, elevational view of the bumper of FIG. 1 the left side being a mirror image thereof;

FIG. 5 is a rear elevational view of the bumper of FIG. 1;

FIG. 6 is a bottom plan view of the bumper of FIG. 1;

FIG. 7 is a perspective view of a vehicle front bumper of an over the highway heavy duty vehicle designed primarily for use in an axle forward vehicle;

FIG. 8 is a top plan view of the bumper of FIG. 7;

FIG. 9 is a left side elevational view, as viewed from the left of FIG. 7, of the bumper of FIG. 7; the right side being a mirror image thereof;

FIG. 10 is a front elevational view of the bumper of FIG. 7;

FIG. 11 is a bottom plan view of the bumper of FIG. 7;

FIG. 12 is a front elevational view of another embodiment of a bumper for another axle forward vehicle utilizing the same central section as the embodiments of FIGS. 1 and 7;

FIG. 13 is an end view of the embodiment of FIG. 12 as seen from the right of FIG. 12, the left hand end being a mirror image thereof;

FIG. 14 is a rear elevational view of the embodiment of FIG. 12; and,

FIG. 15 is a bottom plan view of the embodiment of FIG. 12.

1 Claim, 6 Drawing Sheets

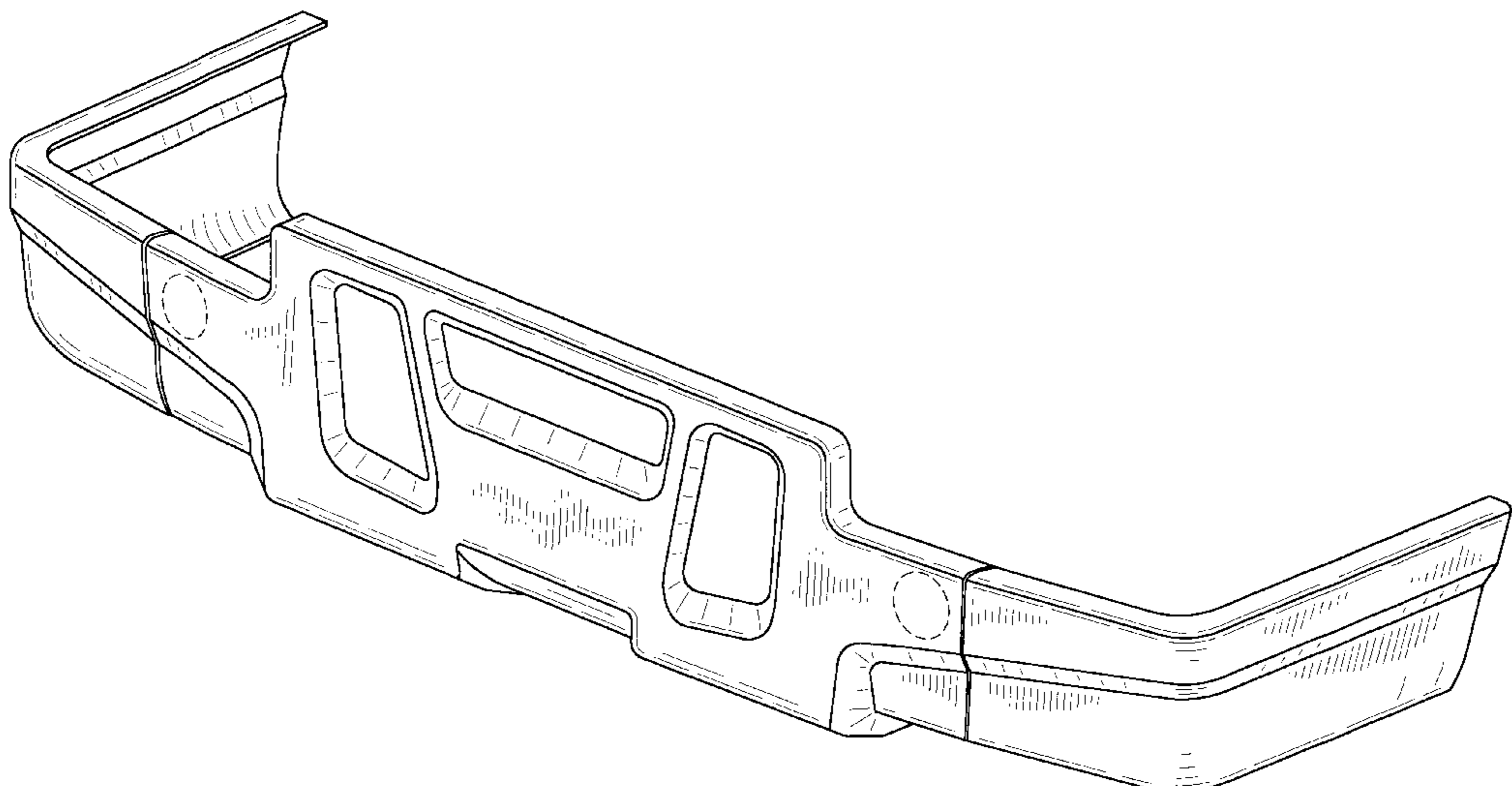

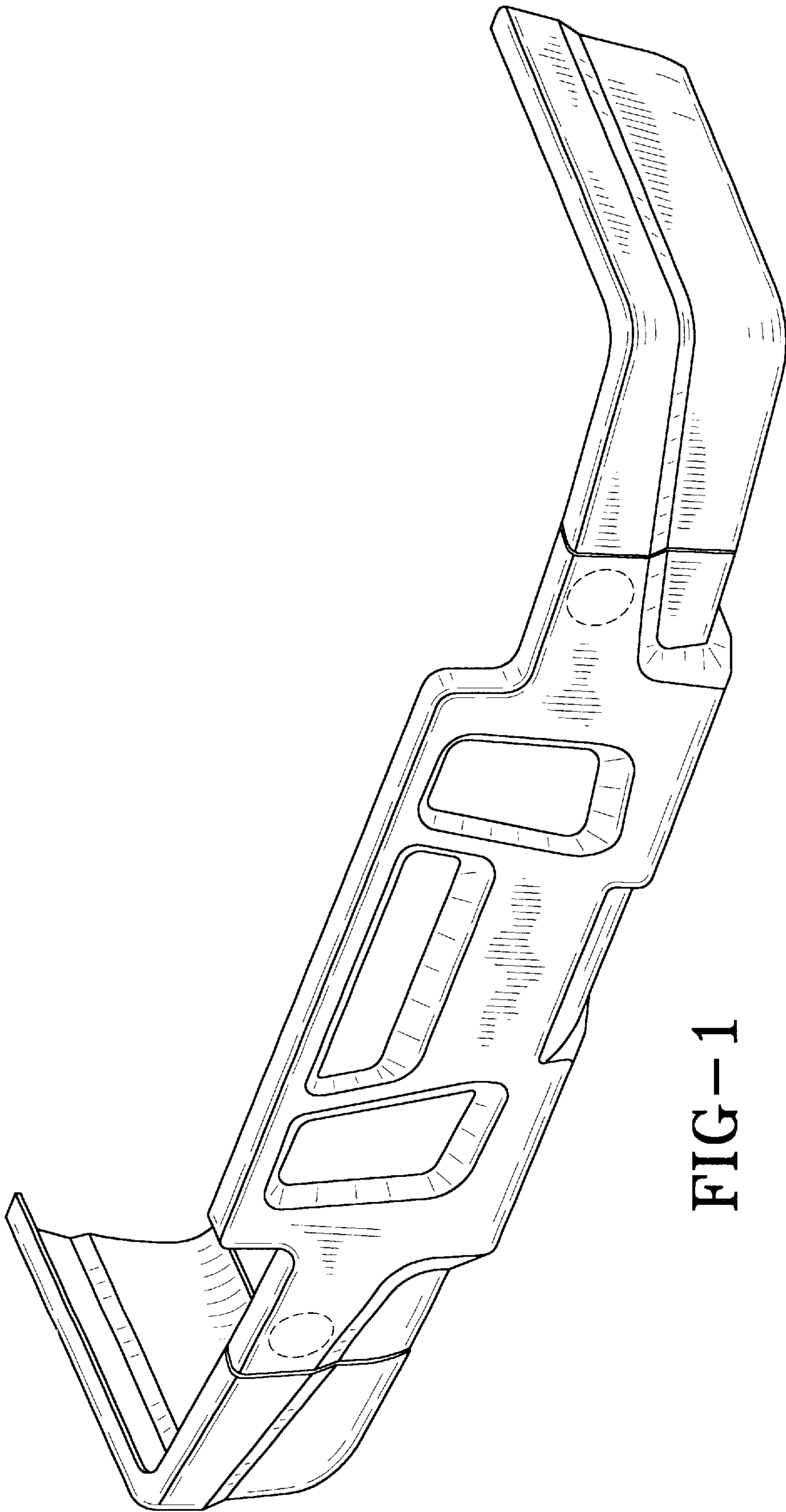

FIG-1

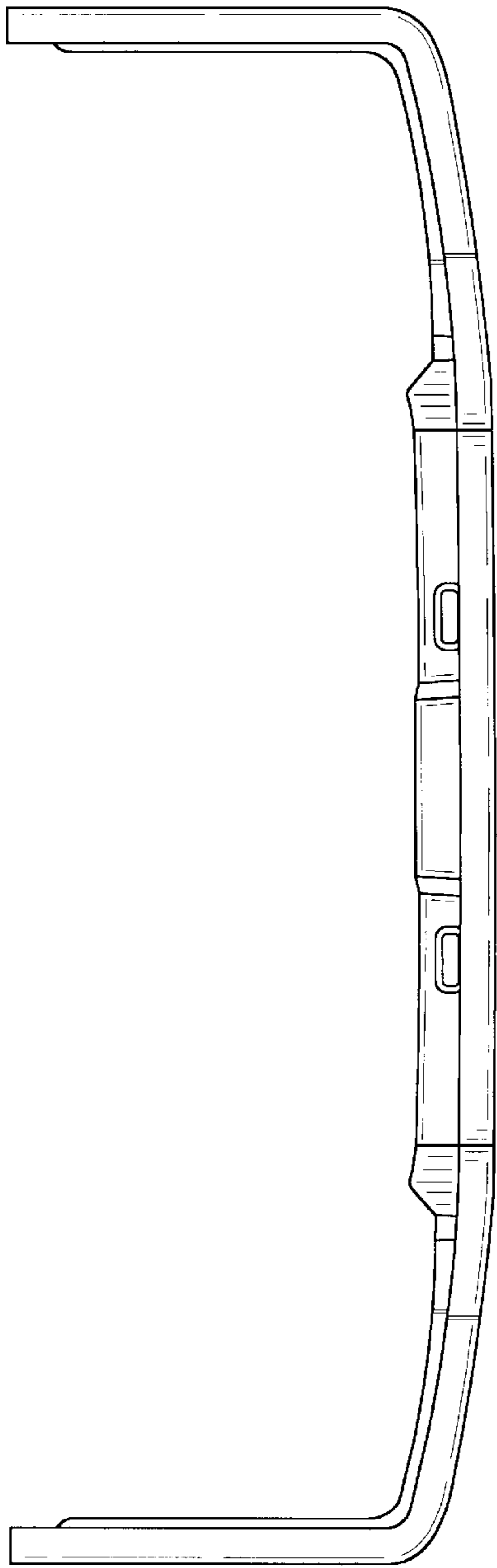

FIG-2

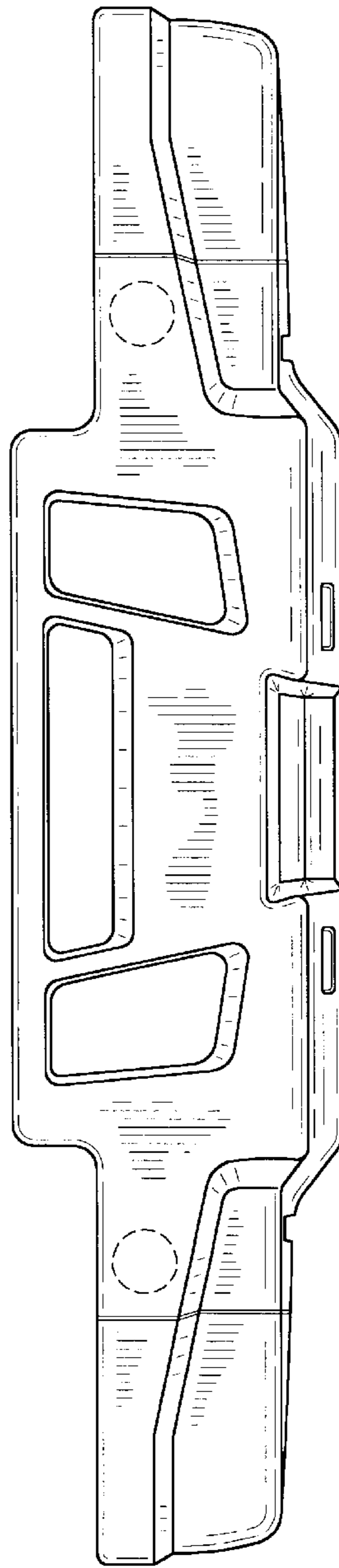

FIG-3

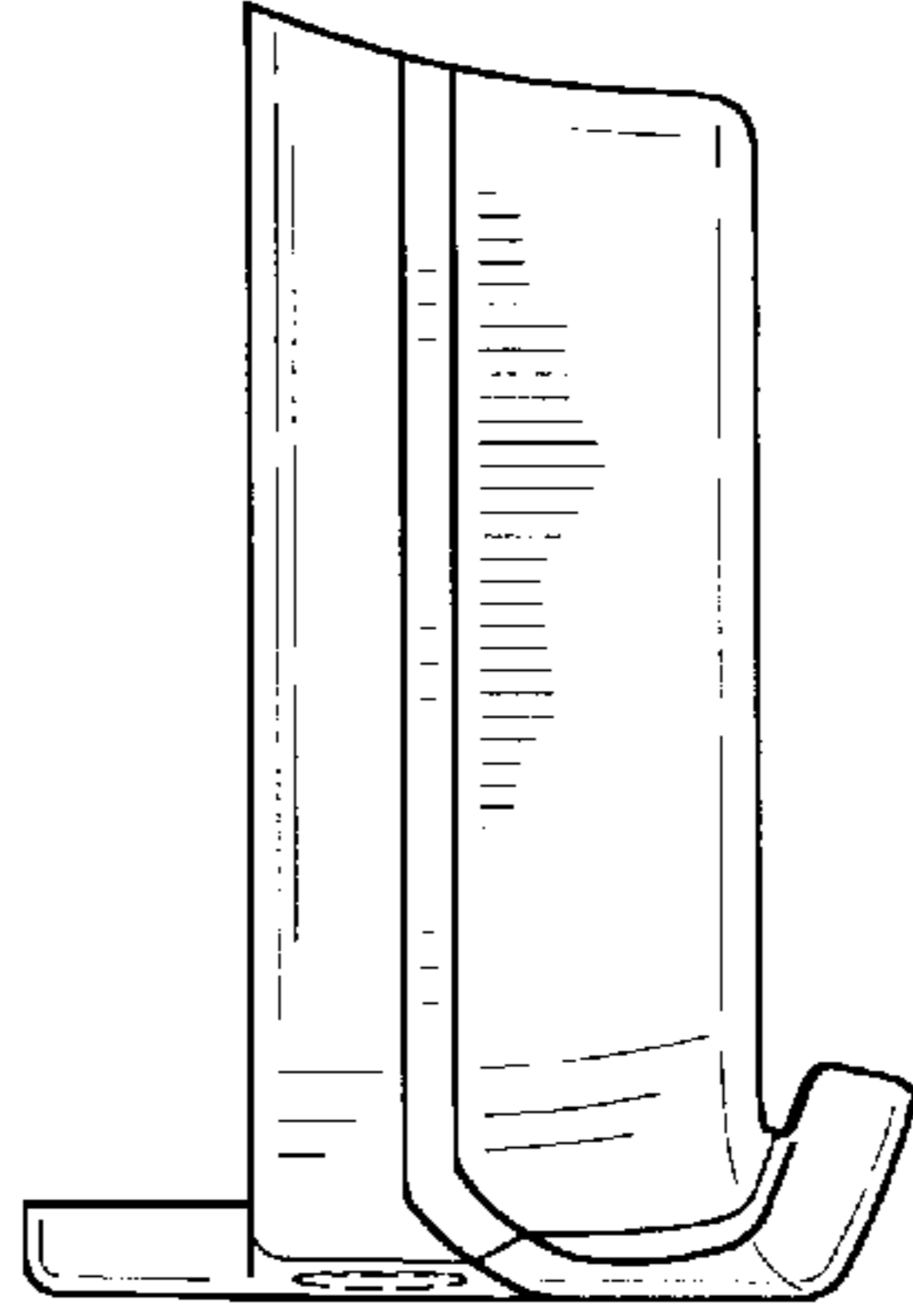

FIG-4

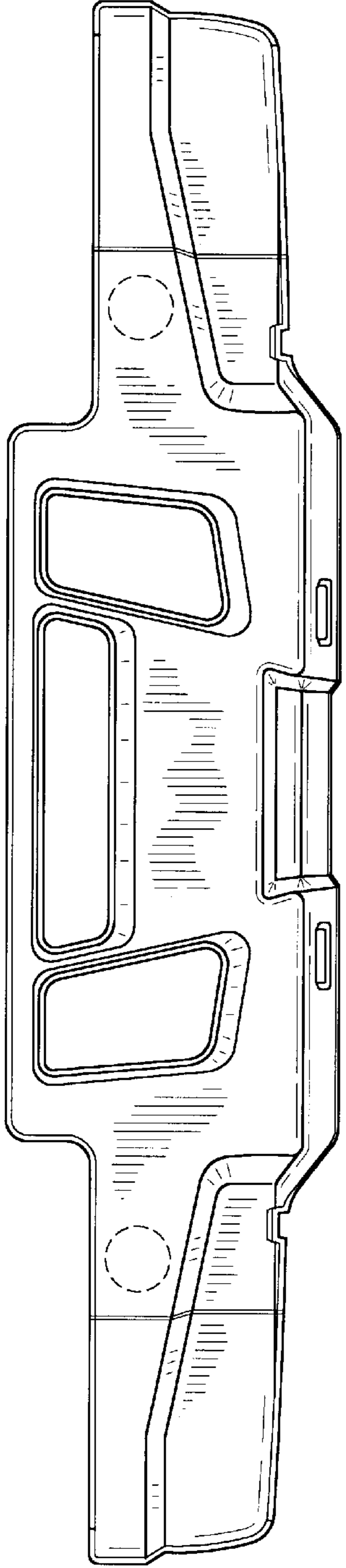

FIG-5

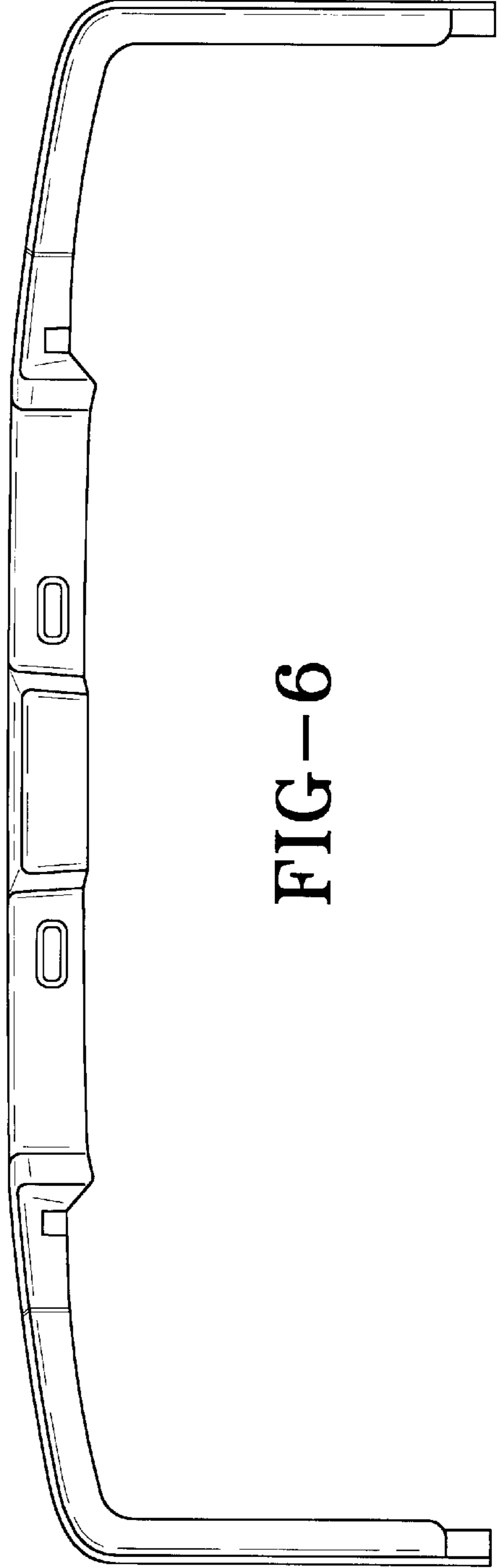

FIG-6

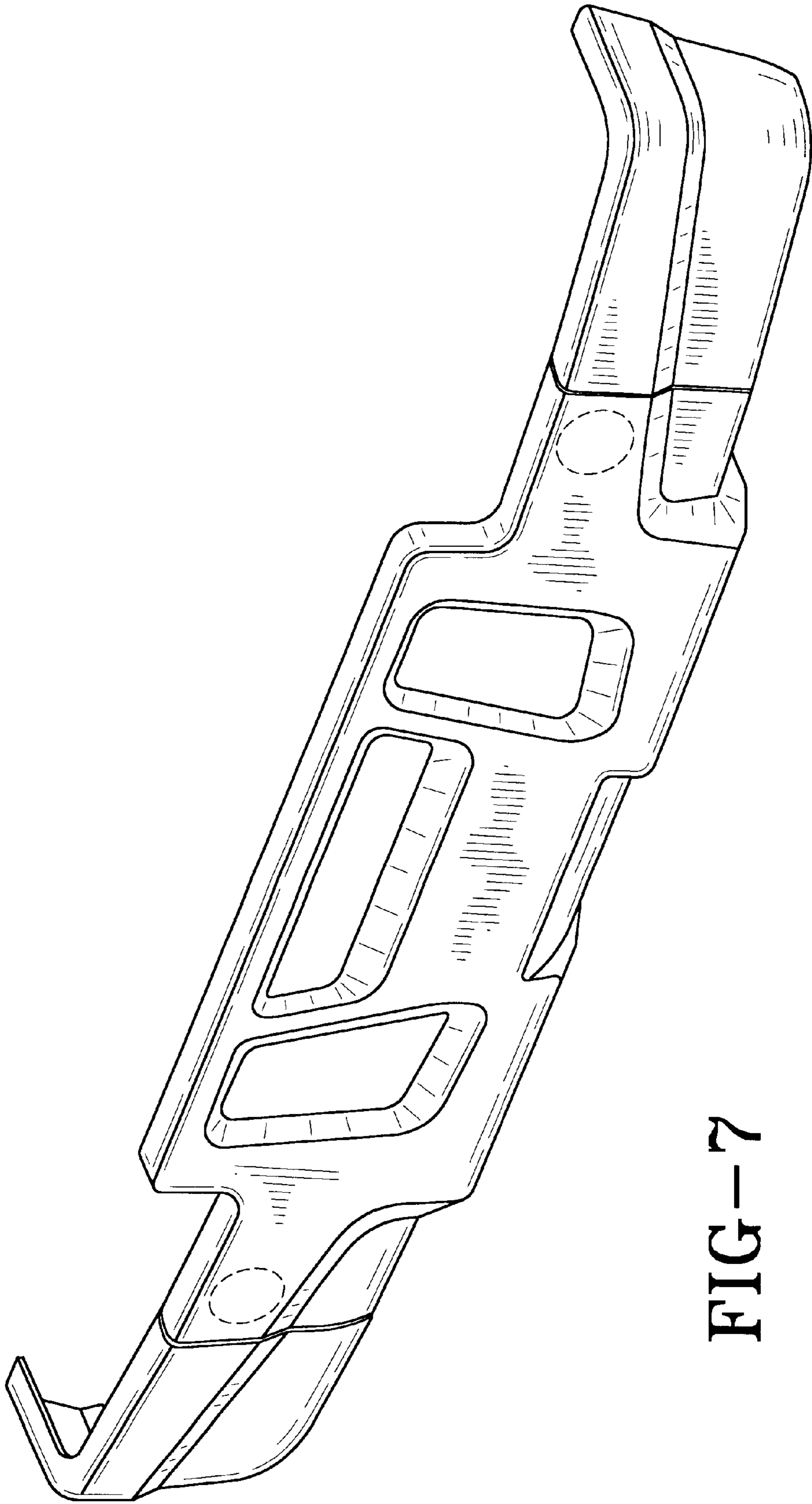

FIG-7

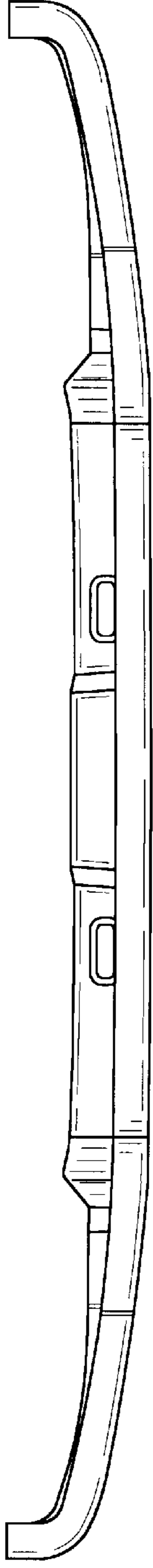

FIG-8

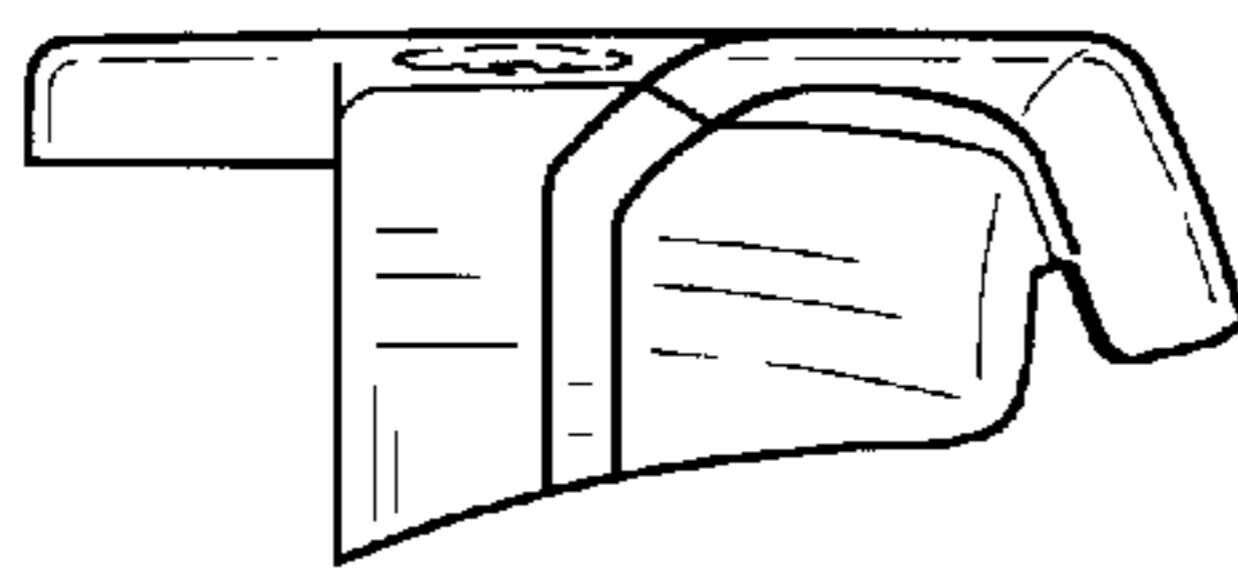

FIG-9

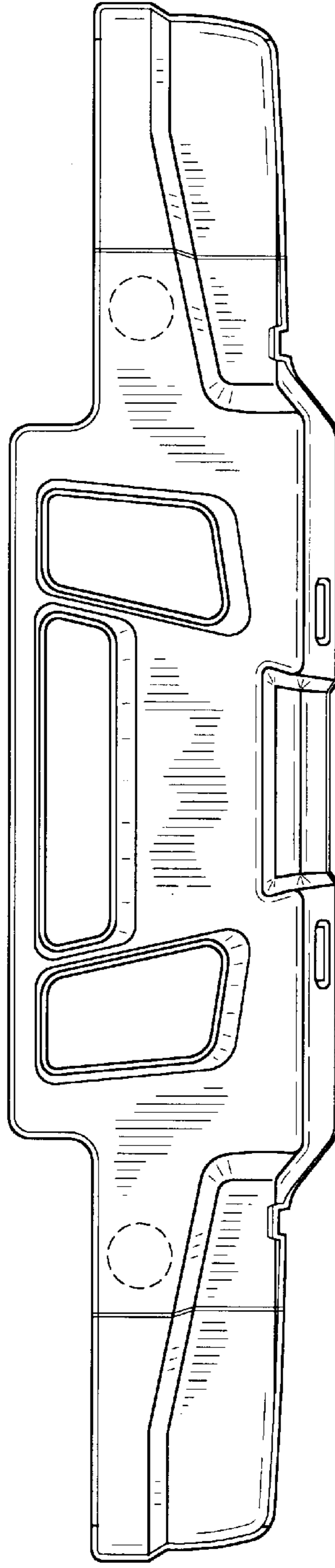

FIG-10



FIG-11

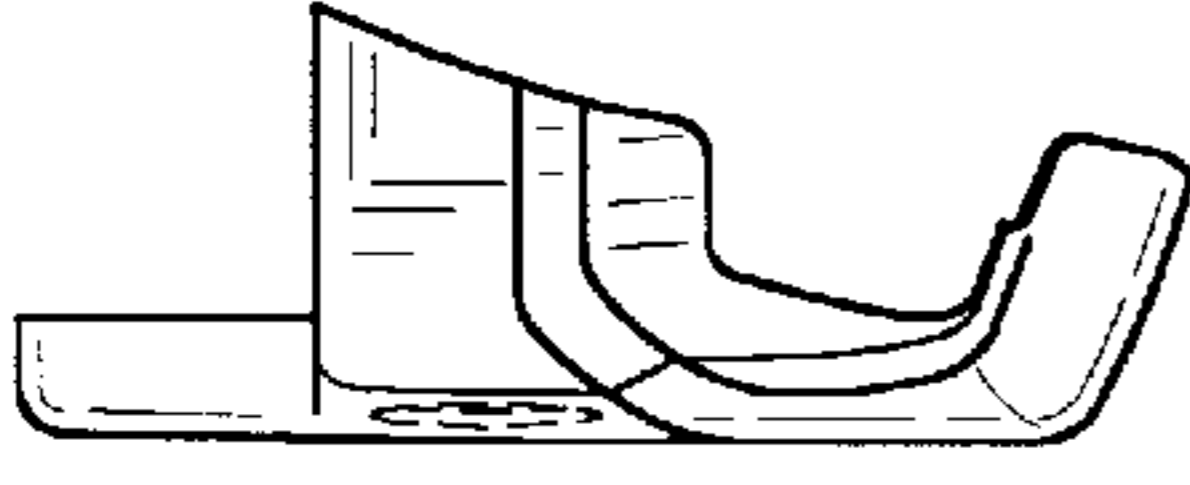

FIG-13

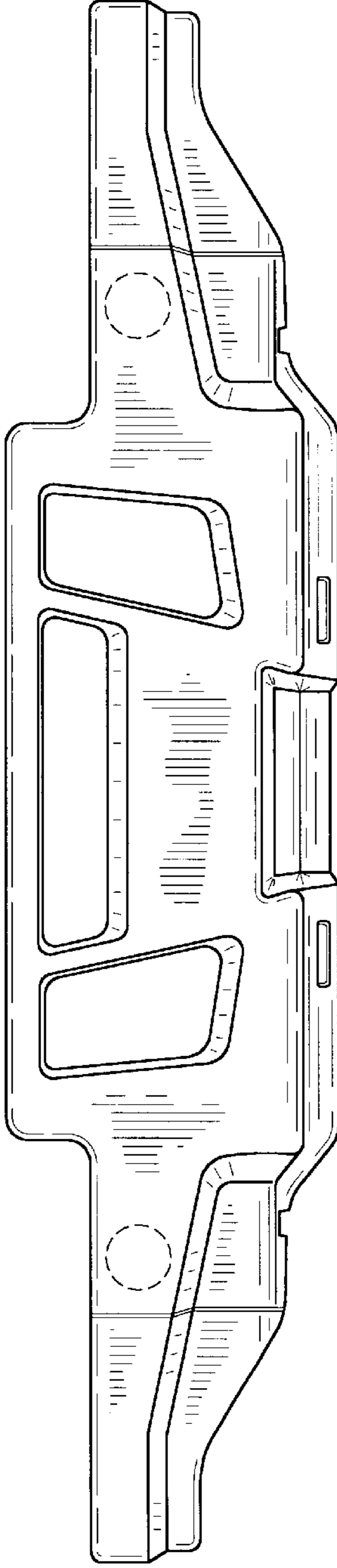

FIG-12

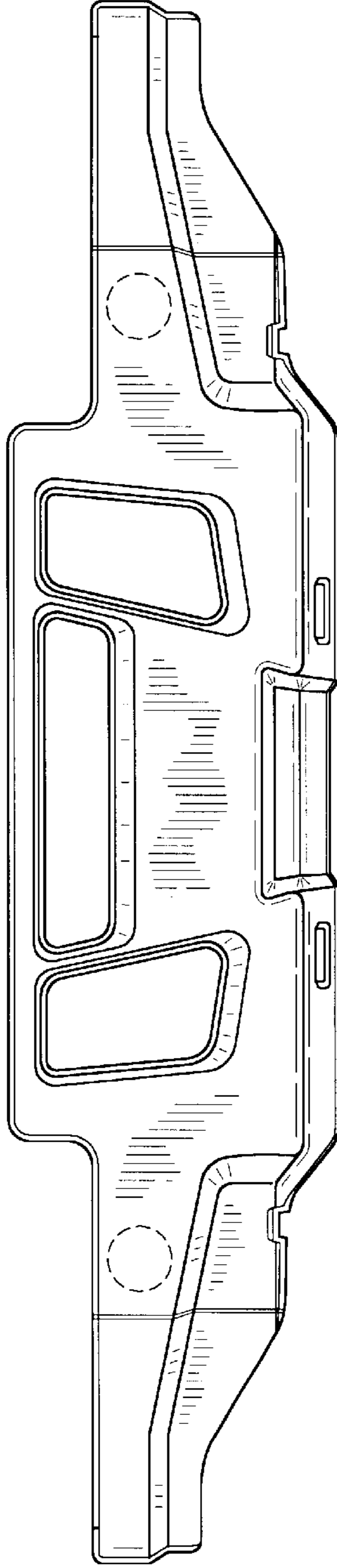

FIG-14



FIG-15