



US00D460022S

(12) **United States Design Patent**
Hsu et al.

(10) **Patent No.:** **US D460,022 S**

(45) **Date of Patent:** **** Jul. 9, 2002**

(54) **VEHICLE BODY**

(75) Inventors: **Ricky Hsu**, Gardena; **Tatsuya Oda**,
Rancho Palos Verdes, both of CA (US)

(73) Assignee: **Honda Giken Kogyo Kabushiki**
Kaisha, Tokyo (JP)

(**) Term: **14 Years**

(21) Appl. No.: **29/148,250**

(22) Filed: **Sep. 18, 2001**

(51) **LOC (7) Cl.** **12-08**

(52) **U.S. Cl.** **D12/91**

(58) **Field of Search** D12/90-92; 296/185

(56) **References Cited**

U.S. PATENT DOCUMENTS

D418,087 S * 12/1999 Ueno D12/91

D422,533 S * 4/2000 Uetmatsu D12/91

D444,101 S * 6/2001 Pfeiffer et al. D12/191

* cited by examiner

Primary Examiner—Melody N. Brown

(74) *Attorney, Agent, or Firm*—Banner & Witcoff, Ltd.

(57) **CLAIM**

The ornamental design for a vehicle body, as shown and described.

DESCRIPTION

FIG. 1 is a front perspective view of a vehicle body showing our new design;

FIG. 2 is a rear perspective view thereof;

FIG. 3 is a side elevational view thereof with the other side being a mirror image;

FIG. 4 is a front elevational view thereof; and,

FIG. 5 is a rear elevational view thereof.

The broken line representations of the rectangles on the front and rear of the vehicle, and the wheels and tires are for illustrative purposes only and form no part of the claimed design.

1 Claim, 3 Drawing Sheets

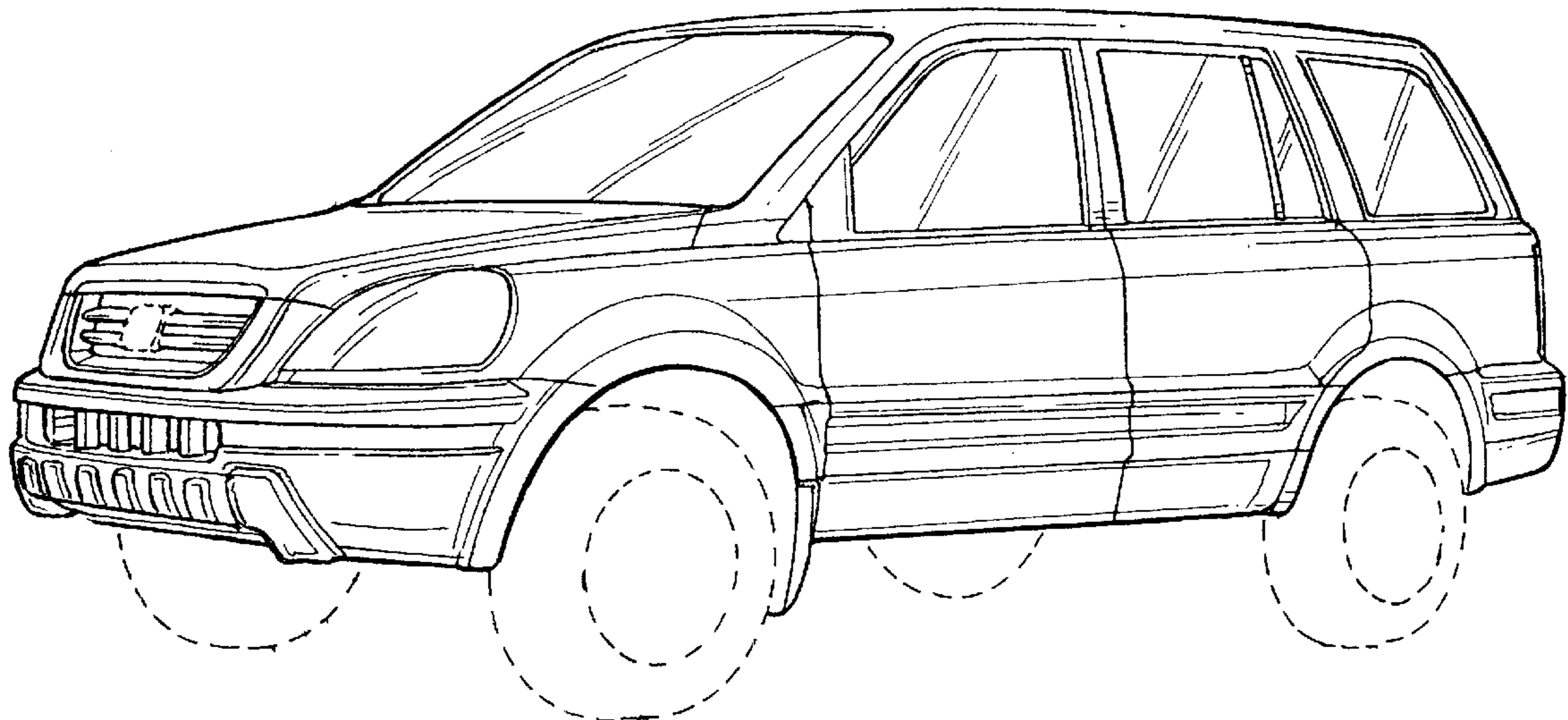

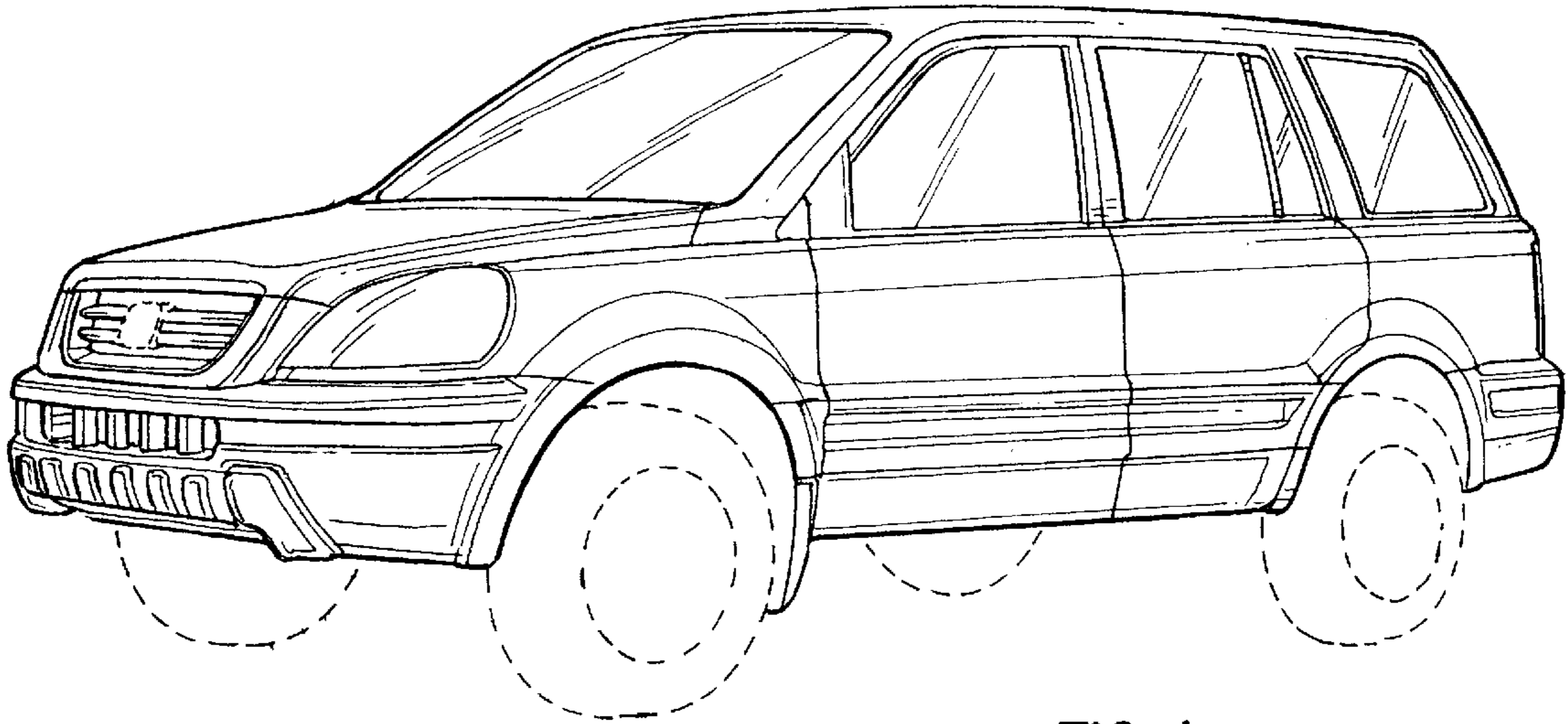

FIG. 1

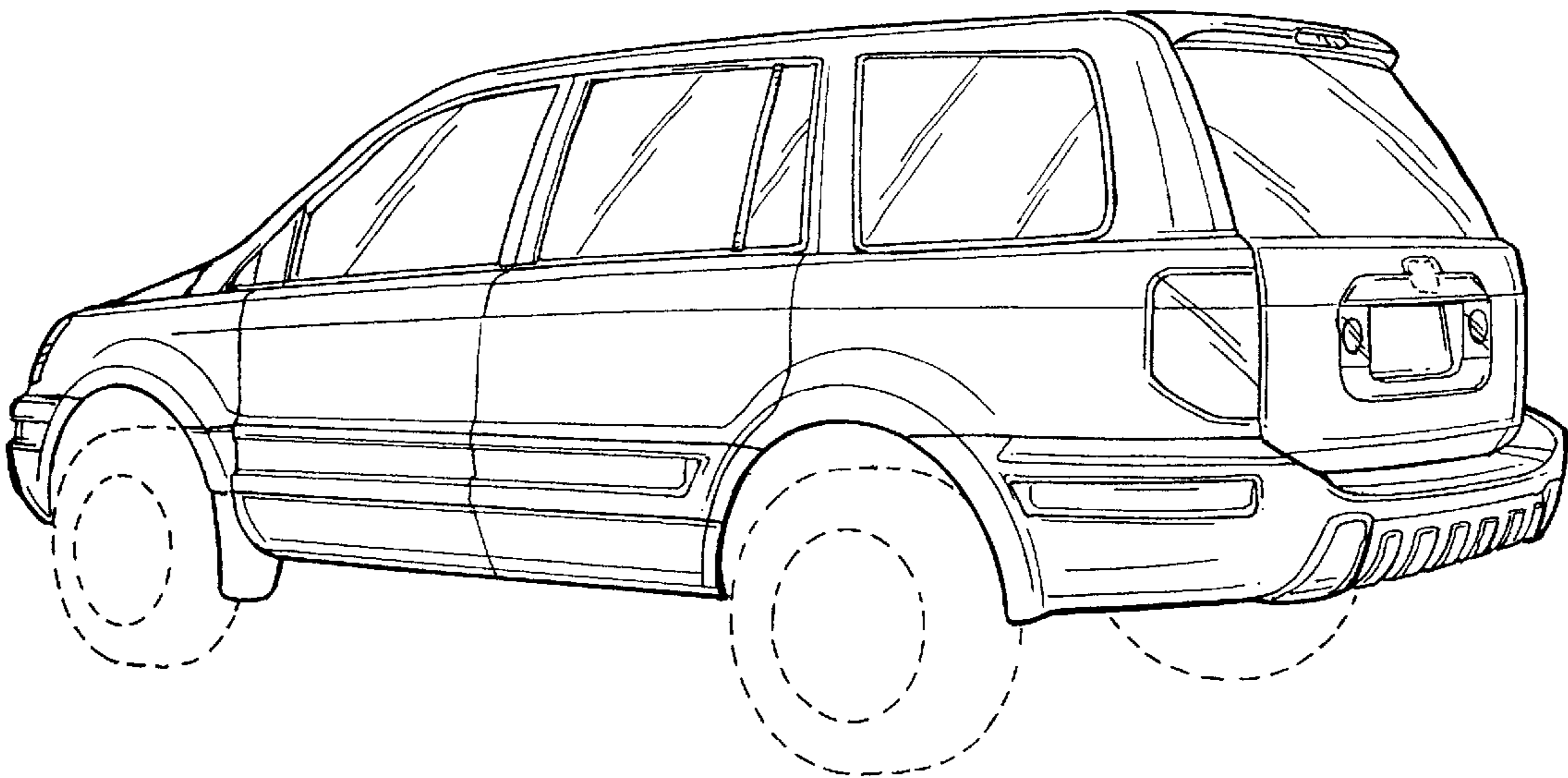

FIG. 2

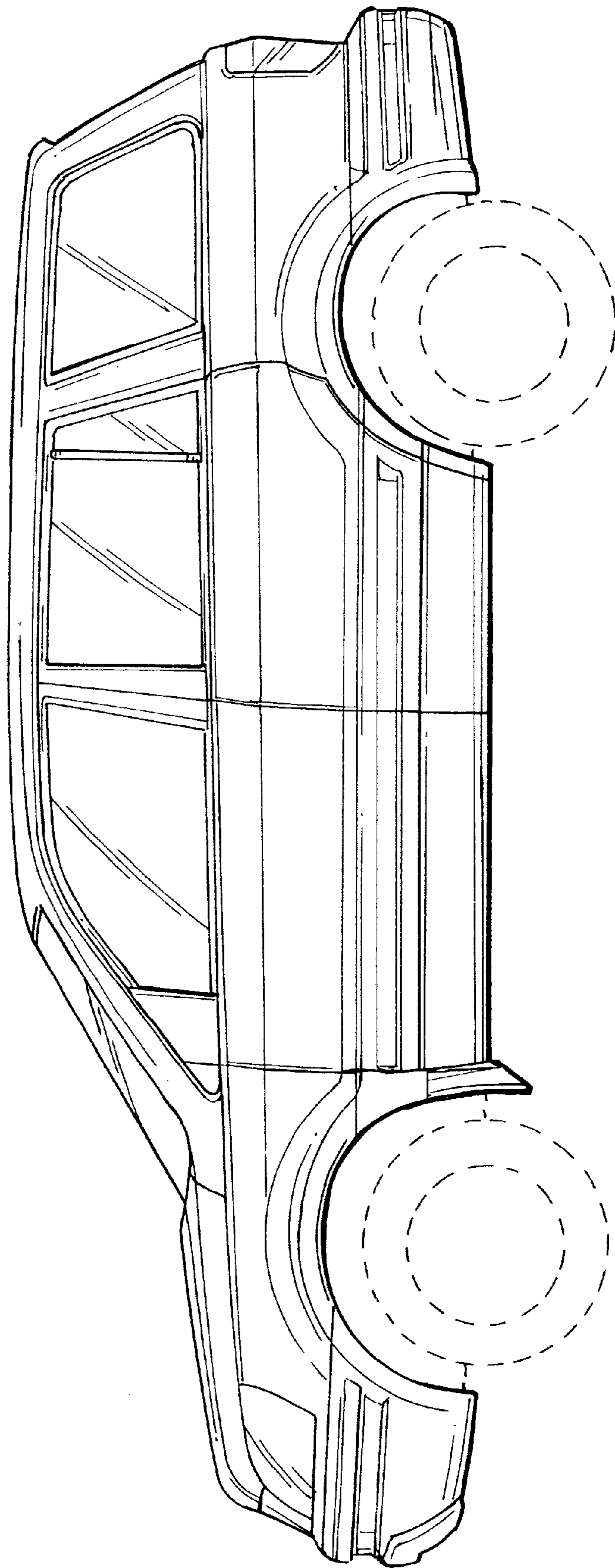

FIG. 3

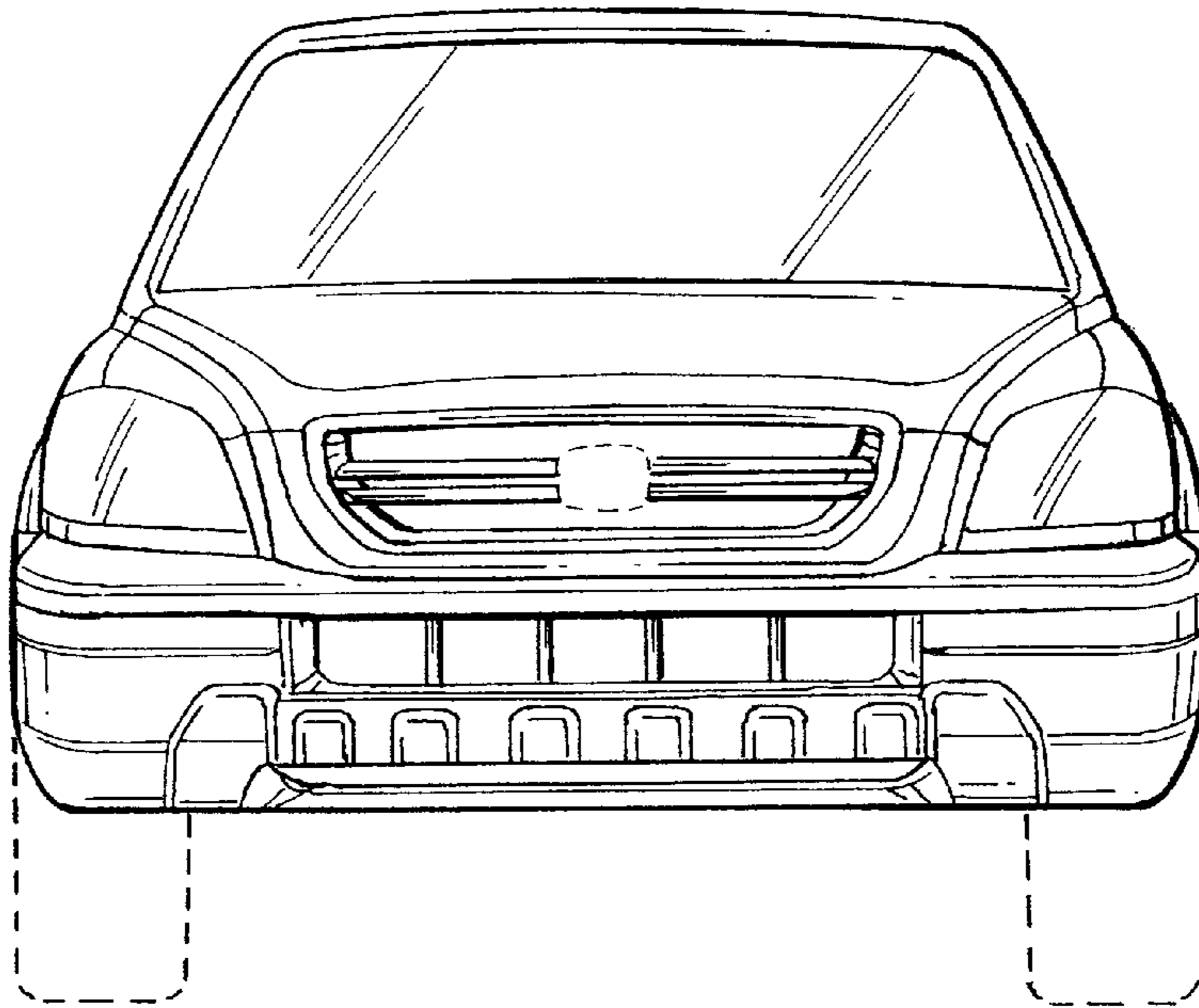

FIG. 4

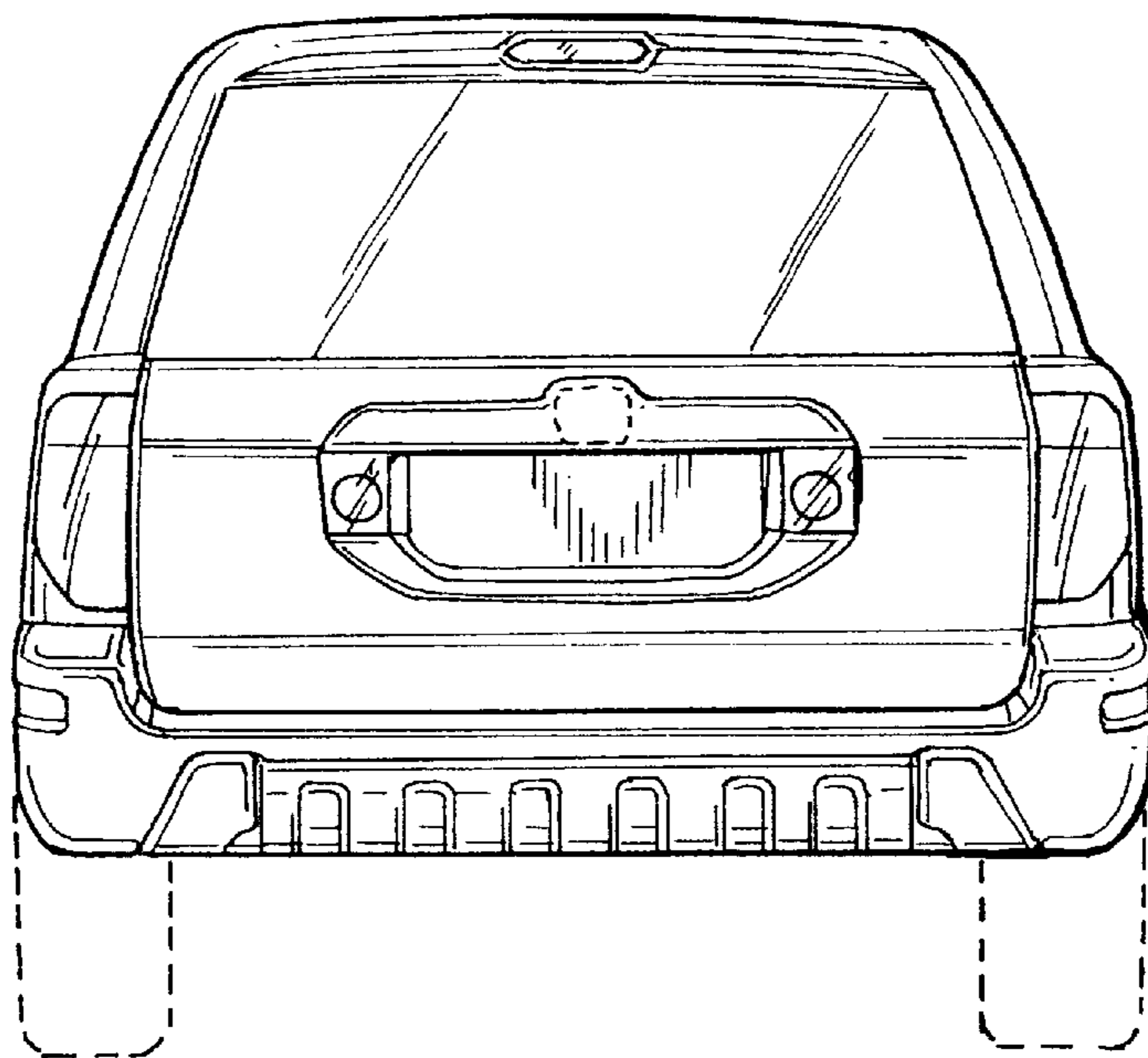

FIG. 5