



US00D459697S

(12) **United States Design Patent**  
**Schaus**

(10) **Patent No.: US D459,697 S**

(45) **Date of Patent: \*\* Jul. 2, 2002**

(54) **PORTION OF A SPARK PLUG BODY**

(76) Inventor: **Robert J. Schaus**, 15026 Oxnard St.,  
Van Nuys, CA (US) 91411

(\*\*) Term: **14 Years**

(21) Appl. No.: **29/149,880**

(22) Filed: **Oct. 17, 2001**

(51) **LOC (7) Cl. .... 13-03**

(52) **U.S. Cl. .... D13/127**

(58) **Field of Search .... D13/127; 313/143,**  
313/144, 135, 118; 174/152 S

(56) **References Cited**

**U.S. PATENT DOCUMENTS**

1,163,281	A	*	12/1915	Sullivan	.....	313/143	X
1,347,874	A	*	7/1920	Rich	.....	313/143	X
D57,080	S	*	2/1921	McNabb et al.	.....	D13/127	
1,409,887	A	*	3/1922	Soyer	.....	313/144	X
D117,232	S	*	10/1939	Lipp	.....	D13/127	
2,266,999	A	*	12/1941	Smith	.....	313/143	X
D141,138	S	*	5/1945	Bowes et al.	.....	D13/127	
D180,302	S	*	5/1957	Thomas	.....	D13/127	
4,308,488	A	*	12/1981	Imai et al.	.....	313/143	X
4,396,855	A	*	8/1983	Imai et al.	.....	313/143	X
5,508,582	A	*	4/1996	Sugimoto et al.	.....	313/118	

\* cited by examiner

*Primary Examiner*—Joel Sincavage

(74) *Attorney, Agent, or Firm*—Mitchell Silberberg &  
Knupp LLP

(57) **CLAIM**

The ornamental design for a portion of a spark plug body, as shown and described.

**DESCRIPTION**

FIG. 1 is a perspective view of a portion of a spark plug body according to the first embodiment of the present invention. FIG. 2 is a front elevational view of the portion of a spark plug body according to the first embodiment of the present invention.

FIG. 3 is a left side elevational view of the portion of a spark plug body according to the first embodiment of the present invention.

FIG. 4 is a bottom plan view of the portion of a spark plug body according to the first embodiment of the present invention.

FIG. 5 is a top plan view of the portion of a spark plug body according to the first embodiment of the present invention.

The rear elevational view according to the first embodiment of the present invention is identical to the front elevational view shown in FIG. 2, and the right side elevational according to the first embodiment of the present invention view is the same as the left side elevational view shown in FIG. 3. The broken lines in FIGS. 1–5 are included for the purpose of illustrating portions of the spark plug that form no part of the first embodiment.

FIG. 6 is a perspective view of a portion of a spark plug body according to the second embodiment of the present invention.

FIG. 7 is a front elevational view of the portion of a spark plug body according to the second embodiment of the present invention.

FIG. 8 is a left side elevational view of the portion of a spark plug body according to the second embodiment of the present invention.

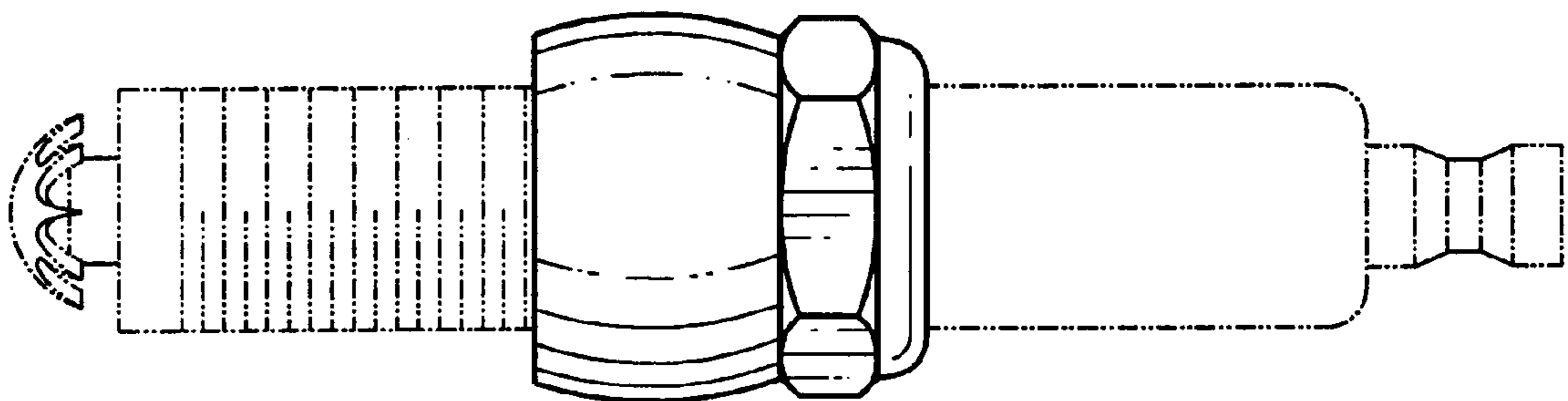
FIG. 9 is a bottom plan view of the portion of a spark plug body according to the second embodiment of the present invention; and,

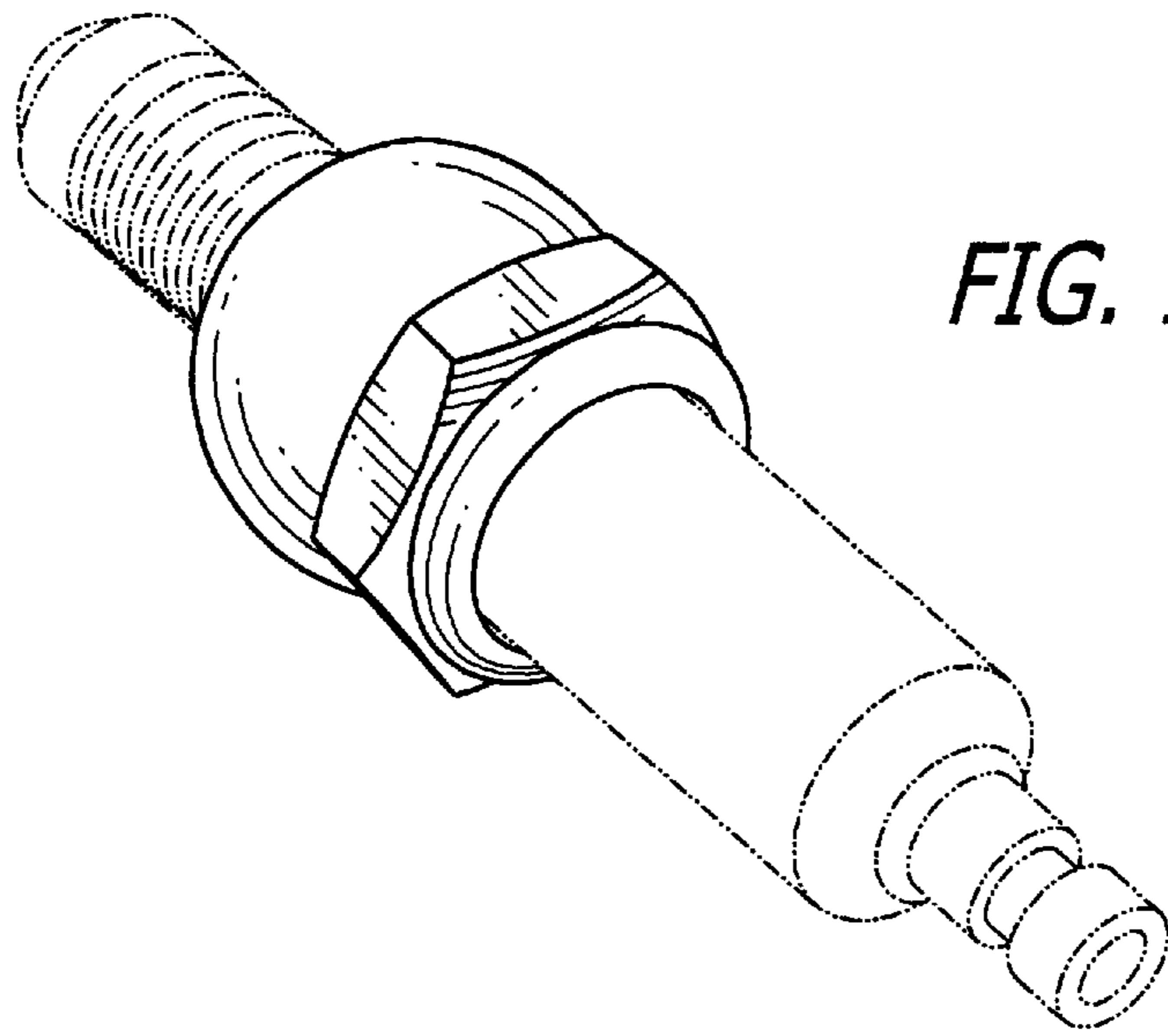
FIG. 10 is a top plan view of the portion of a spark plug body according to the second embodiment of the present invention.

The rear elevational view according to the second embodiment of the present invention is identical to the front elevational view shown in FIG. 7, and the right side elevational according to the second embodiment of the present invention view is the same as the left side elevational view shown in FIG. 8.

The broken lines in FIGS. 6–10 are included for the purpose of illustrating portions of the spark plug that form no part of the second embodiment.

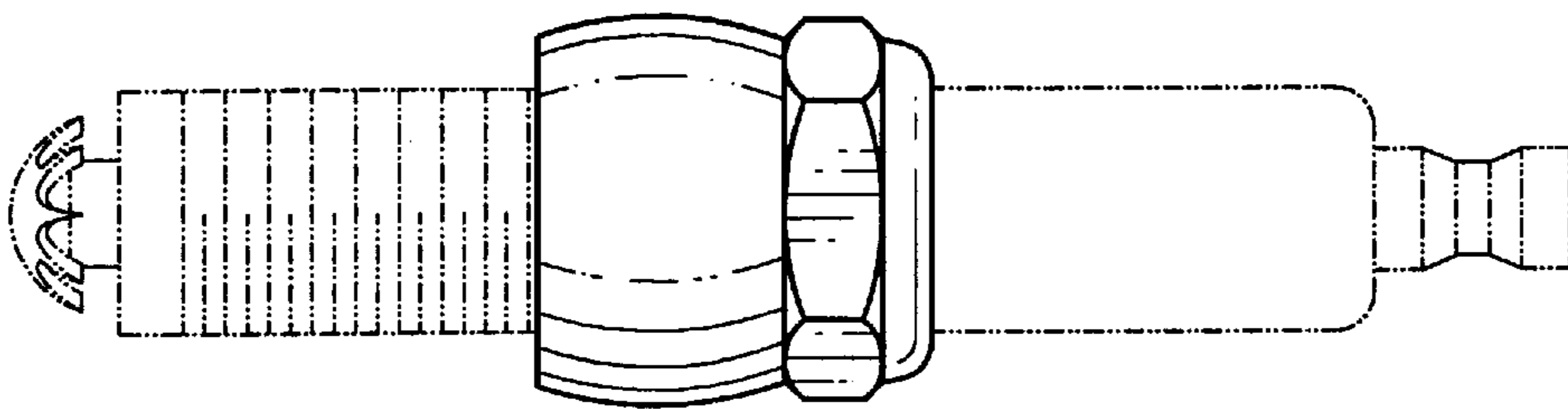
**1 Claim, 2 Drawing Sheets**



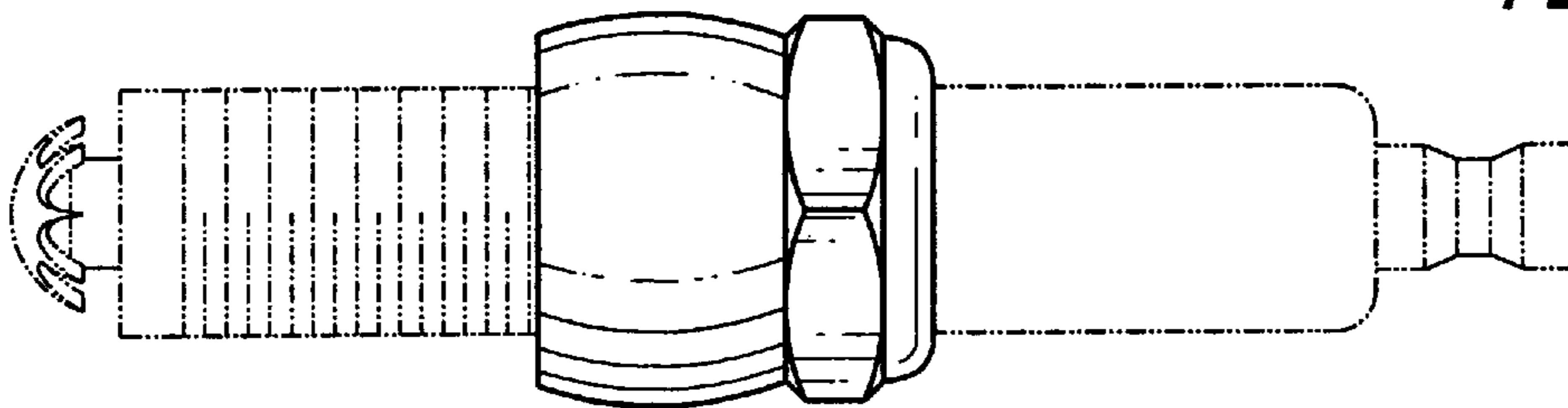


*FIG. 1*

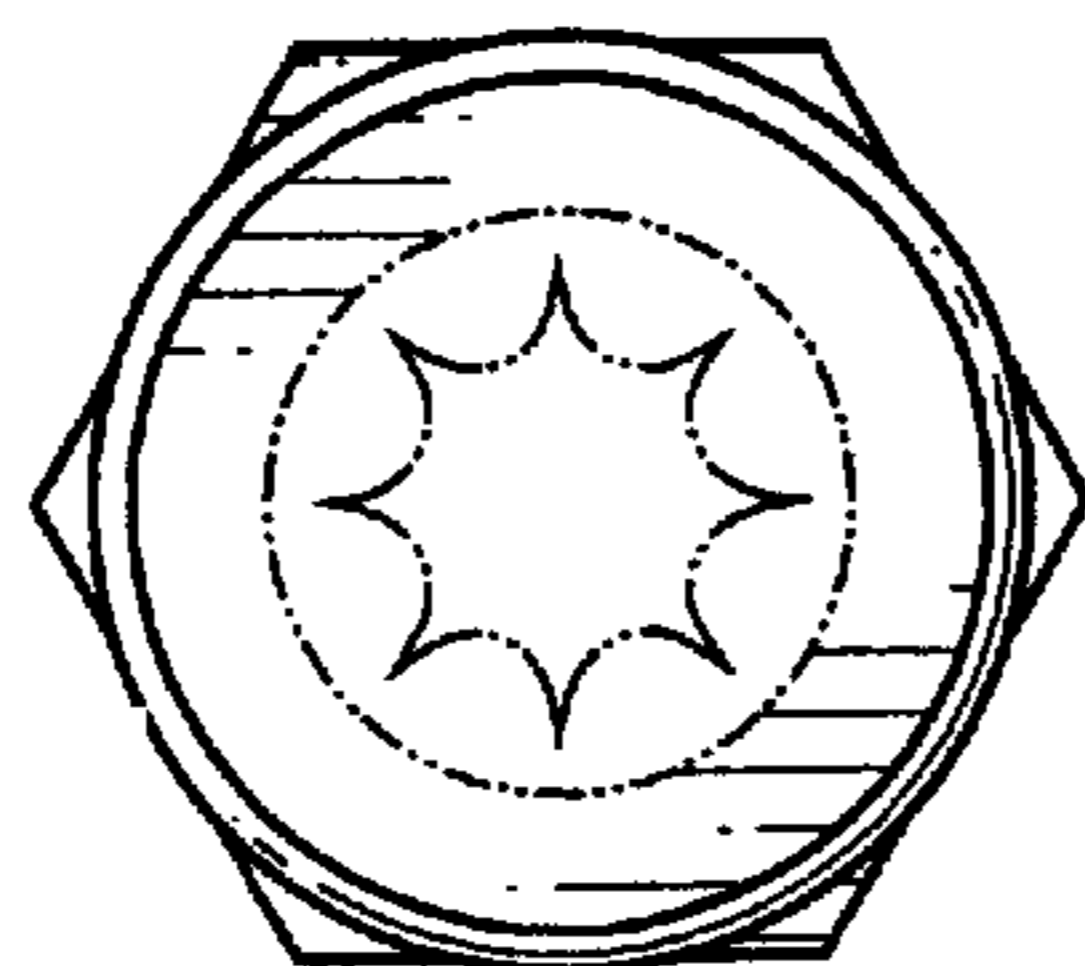
*FIG. 2*



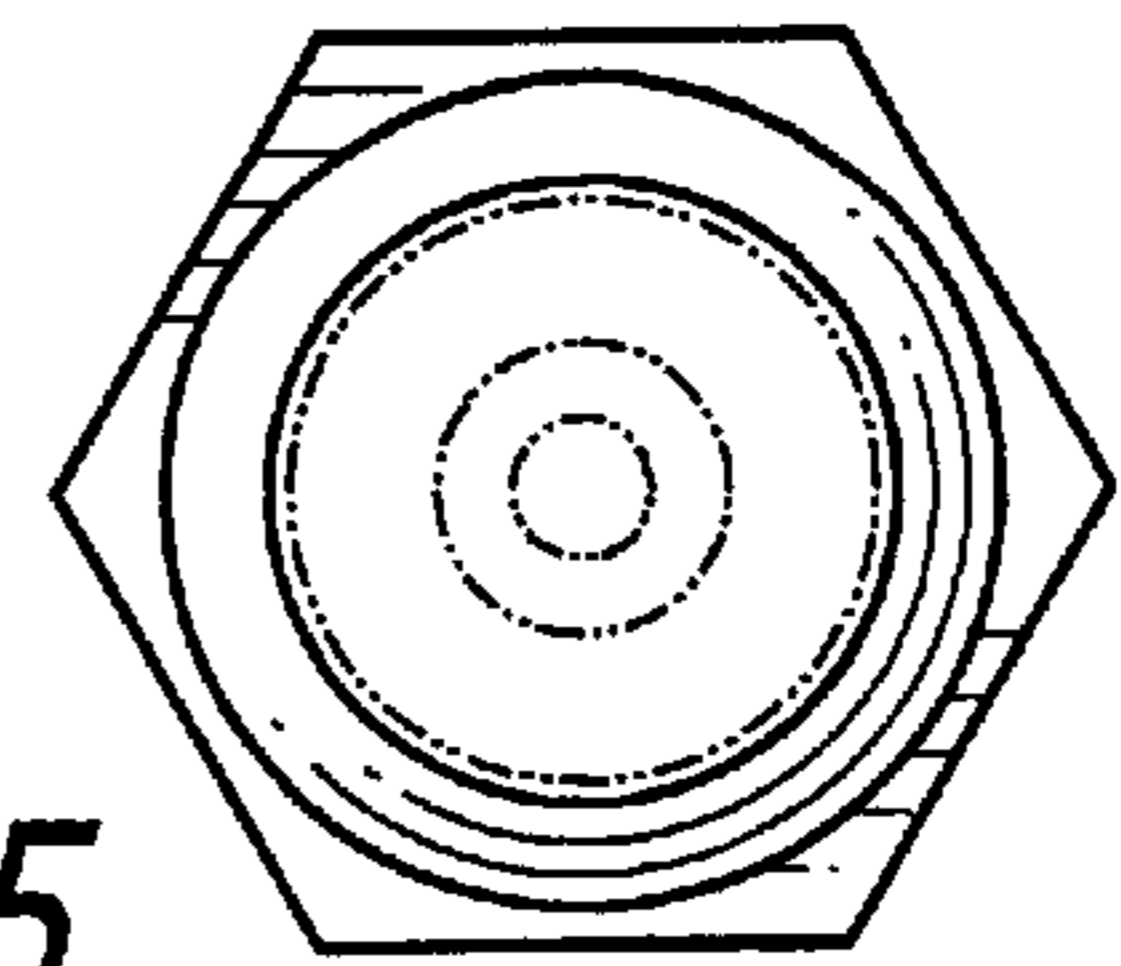
*FIG. 3*

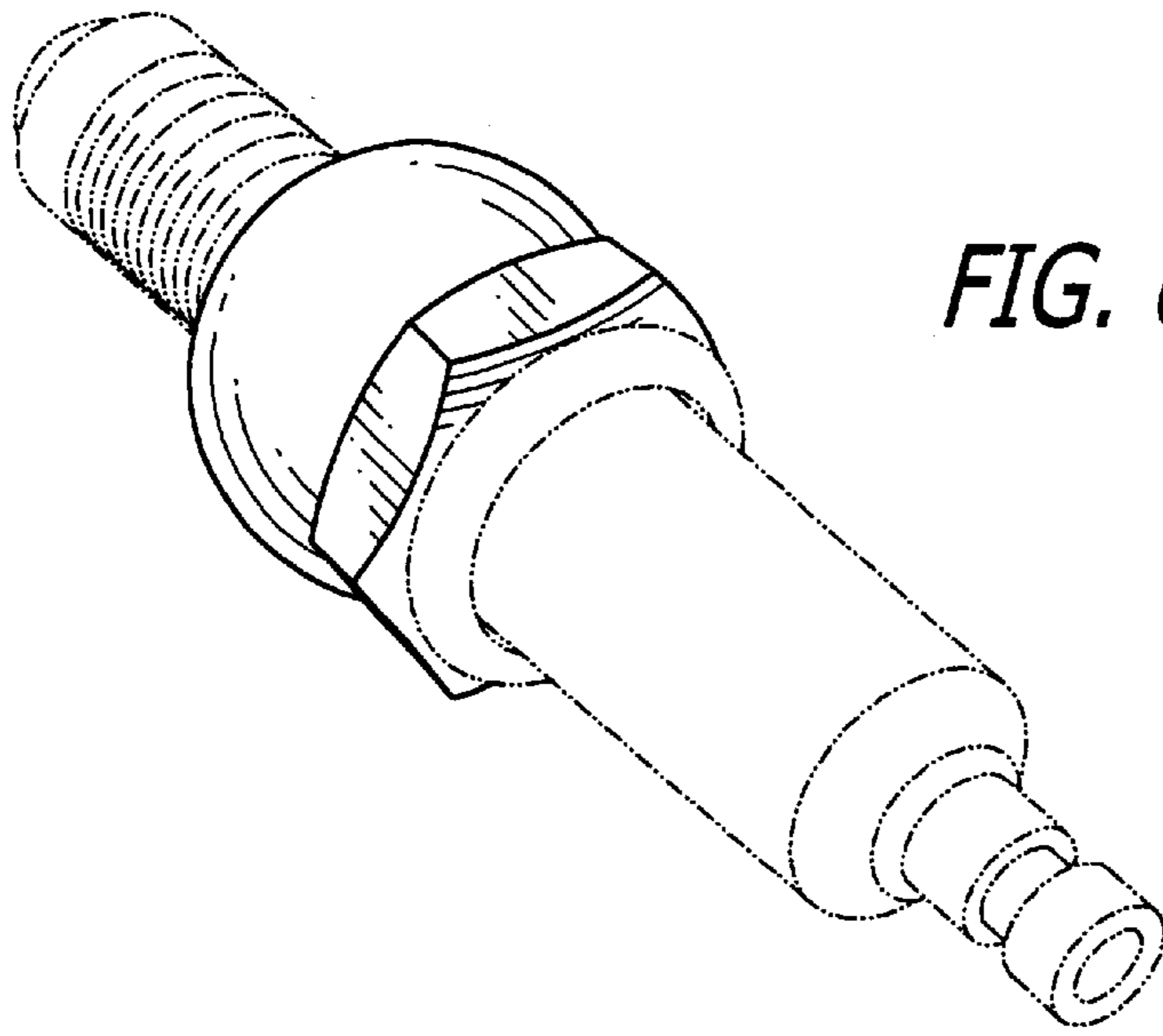


*FIG. 4*



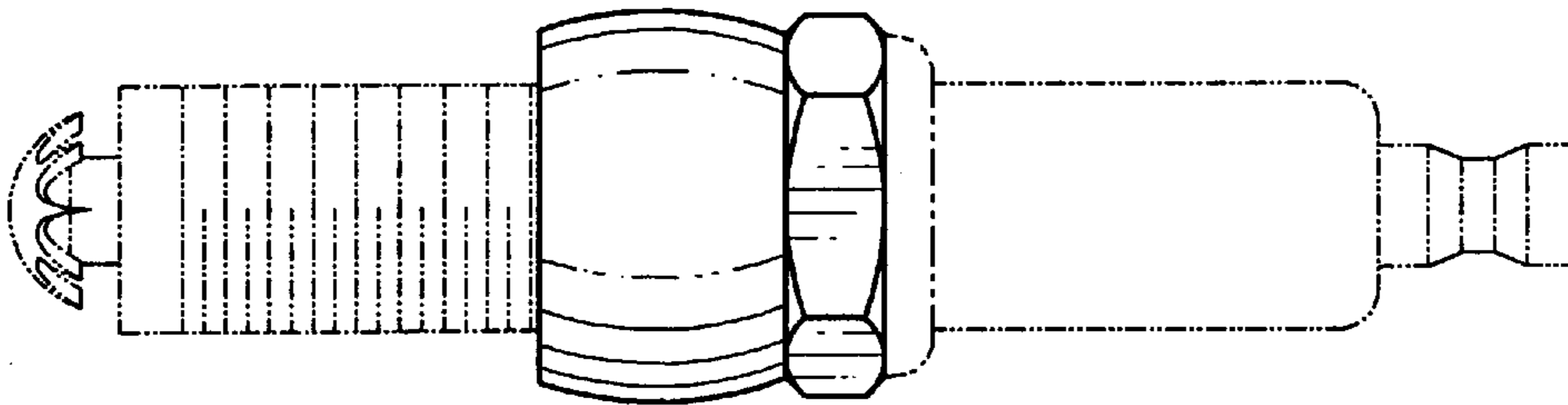
*FIG. 5*



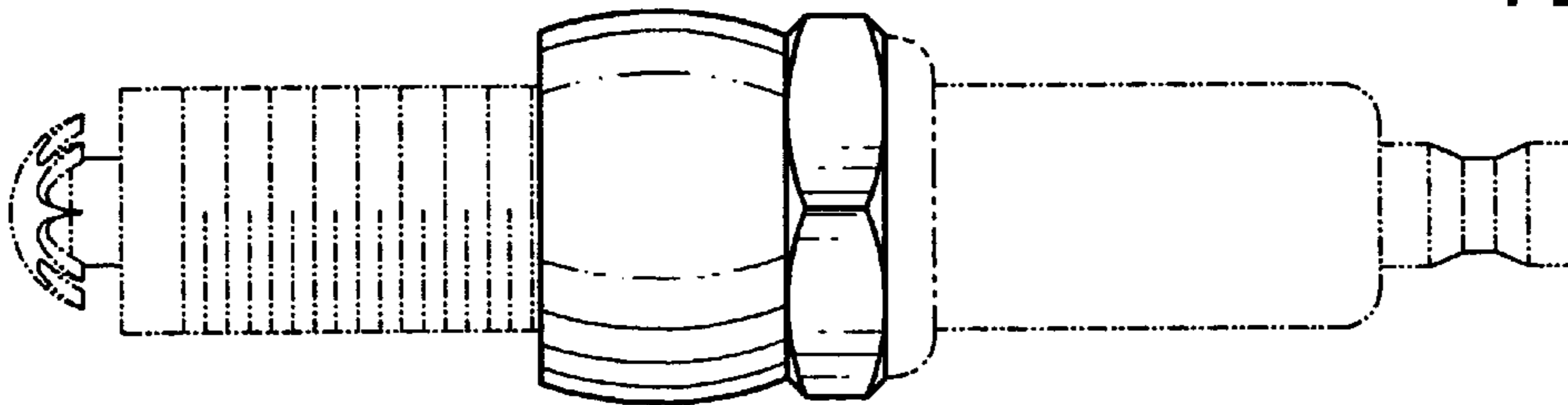


*FIG. 6*

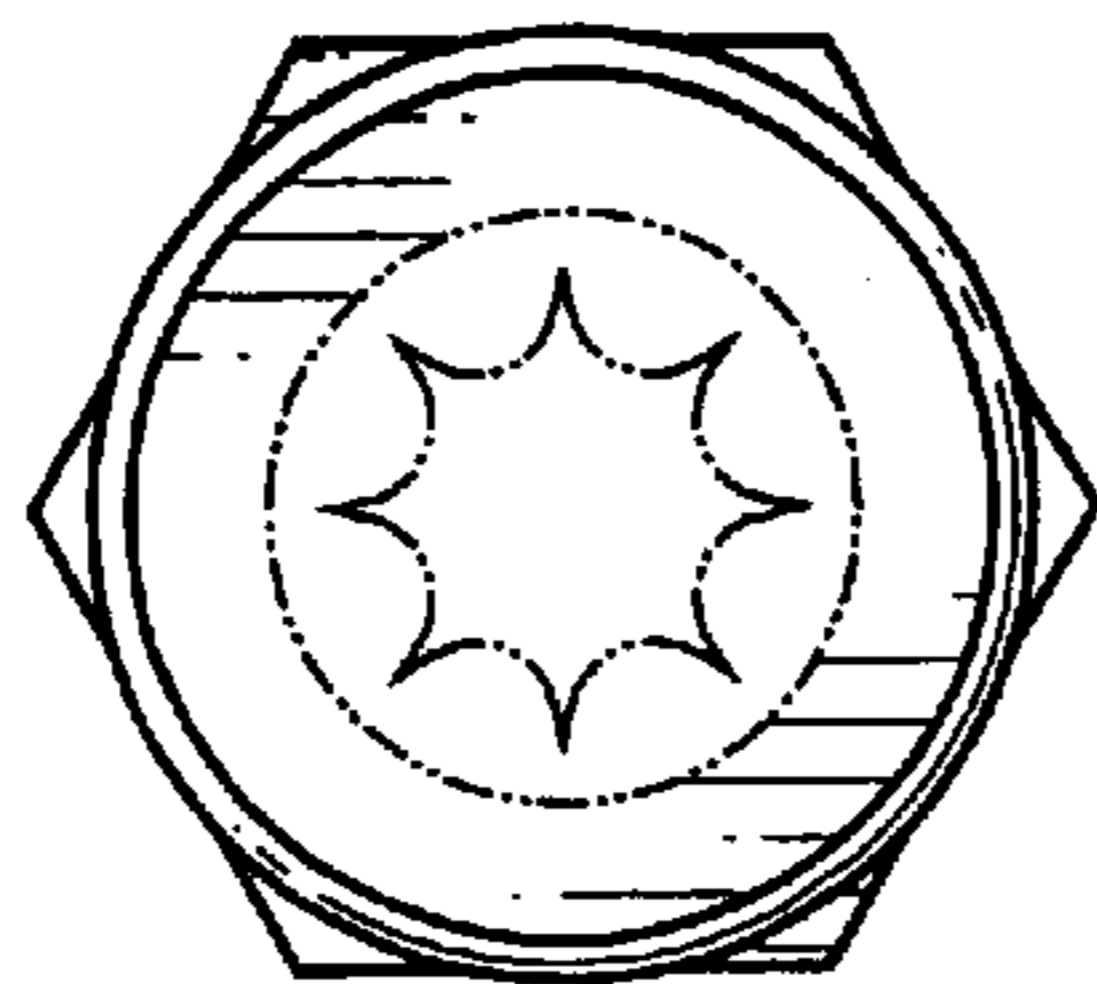
*FIG. 7*



*FIG. 8*



*FIG. 9*



*FIG. 10*

