



US00D459644S

(12) **United States Design Patent**  
**Morgan**

(10) **Patent No.:** **US D459,644 S**

(45) **Date of Patent:** **\*\* Jul. 2, 2002**

(54) **PNEUMATIC TOOL**

(75) **Inventor:** **Fred M. Morgan**, Jackson, TN (US)

(73) **Assignee:** **DeVilbiss Air Power Company**,  
Jackson, TN (US)

(\*\*) **Term:** **14 Years**

(21) **Appl. No.:** **29/149,156**

(22) **Filed:** **Oct. 3, 2001**

(51) **LOC (7) Cl.** ..... **08-05**

(52) **U.S. Cl.** ..... **D8/68**

(58) **Field of Search** ..... D8/49, 61, 62,  
D8/63, 64, 65, 66, 67, 68, 69, 70; 16/430;  
30/388; 81/52, 54, 55, 57.11, 57.13, 57.14,  
57.33, 57.42, 73, 177.1, 177.8, 177.85,  
409, 429, 436, 463, 464, 467, 469, 470,  
900, 901, DIG. 12; 173/13, 15, 19, 47,  
48, 81, 93, 93.5, 93.6, 94, 104, 109, 168,  
169, 170, 171, 176, 178, 180, 181, 213,  
216, 217, 221; 227/2, 8, 10, 66, 111, 112,  
113, 114, 115, 120, 130, 136; 400/156,  
181; 408/20, 120, 122, 124, 125, 234, 241 R,  
241 S; 431/344, 354, 357, 358, 359, 456

(56) **References Cited**

**U.S. PATENT DOCUMENTS**

3,043,274 A \* 7/1962 Quackenbush ..... 173/178  
3,454,059 A \* 7/1969 Sindelar ..... 81/429  
D221,926 S \* 9/1971 Farkas ..... D8/68

D231,597 S \* 5/1974 Dinse ..... D8/68  
4,370,906 A \* 2/1983 Gurries ..... 81/464  
D298,509 S \* 11/1988 Brosius et al. .... D8/68  
D394,995 S \* 6/1998 Cooper ..... D8/68  
D400,416 S \* 11/1998 Zurwelle ..... D8/68  
D406,741 S \* 3/1999 Zurwelle ..... D8/68  
D446,434 S \* 8/2001 Ashbaugh ..... D8/68  
D447,033 S \* 8/2001 Izumisawa ..... D8/68  
6,308,378 B1 \* 10/2001 Mooty et al. .... 408/124

\* cited by examiner

*Primary Examiner*—Doris V. Coles

*Assistant Examiner*—T. Chase Nelson

(74) *Attorney, Agent, or Firm*—Suiter & Associates PC

(57) **CLAIM**

The ornamental design for a pneumatic tool, as shown and described.

**DESCRIPTION**

FIG. 1 is top plan view of a pneumatic tool showing my new design;  
FIG. 2 is a front elevation view thereof;  
FIG. 3 is a left side elevation view thereof;  
FIG. 4 is rear elevation view thereof;  
FIG. 5 is a right side elevation view thereof; and,  
FIG. 6 is a bottom plan view thereof.  
The broken lines shown in FIGS. 1, 2, 3, 5, and 6 of the drawing are for illustrative purposes only and form no part of the claimed design.

**1 Claim, 2 Drawing Sheets**

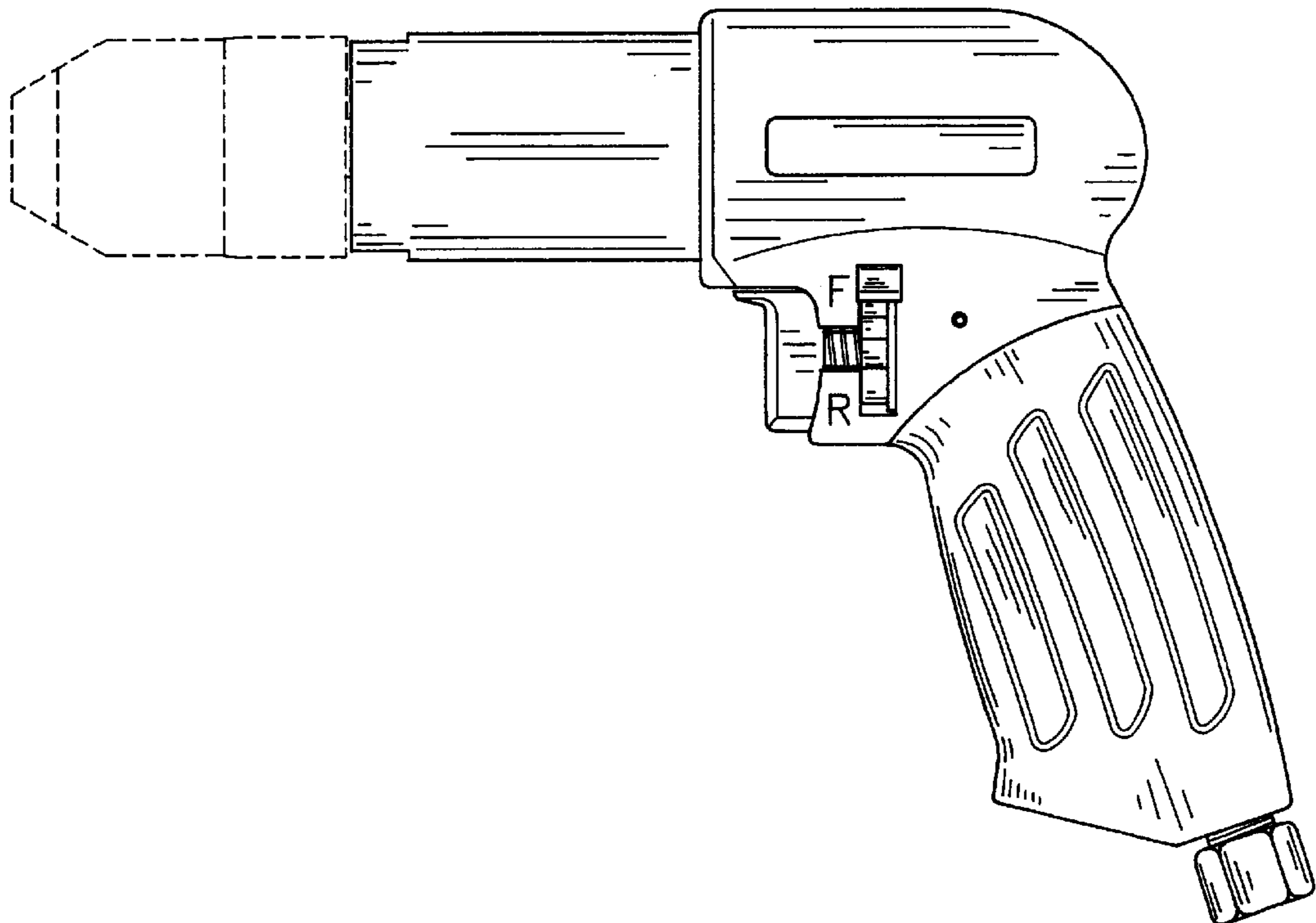

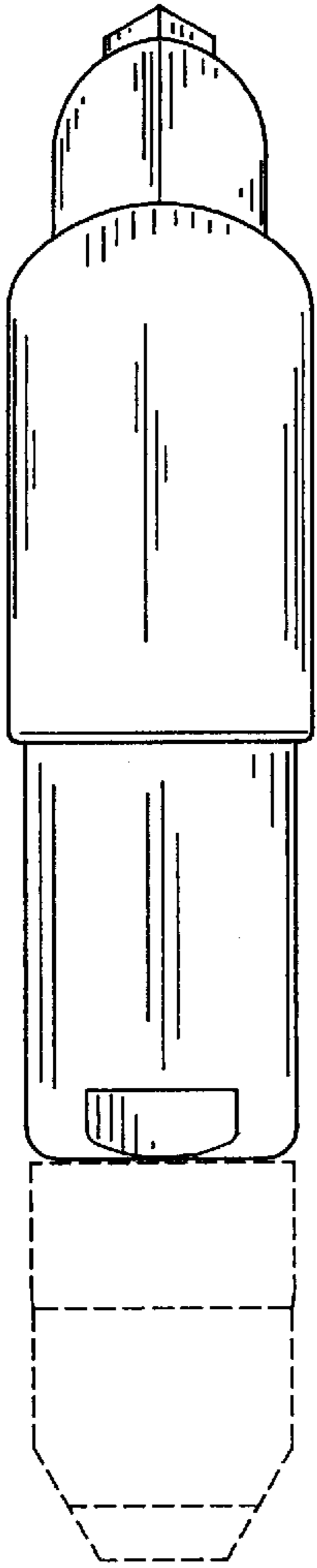

FIG. 1

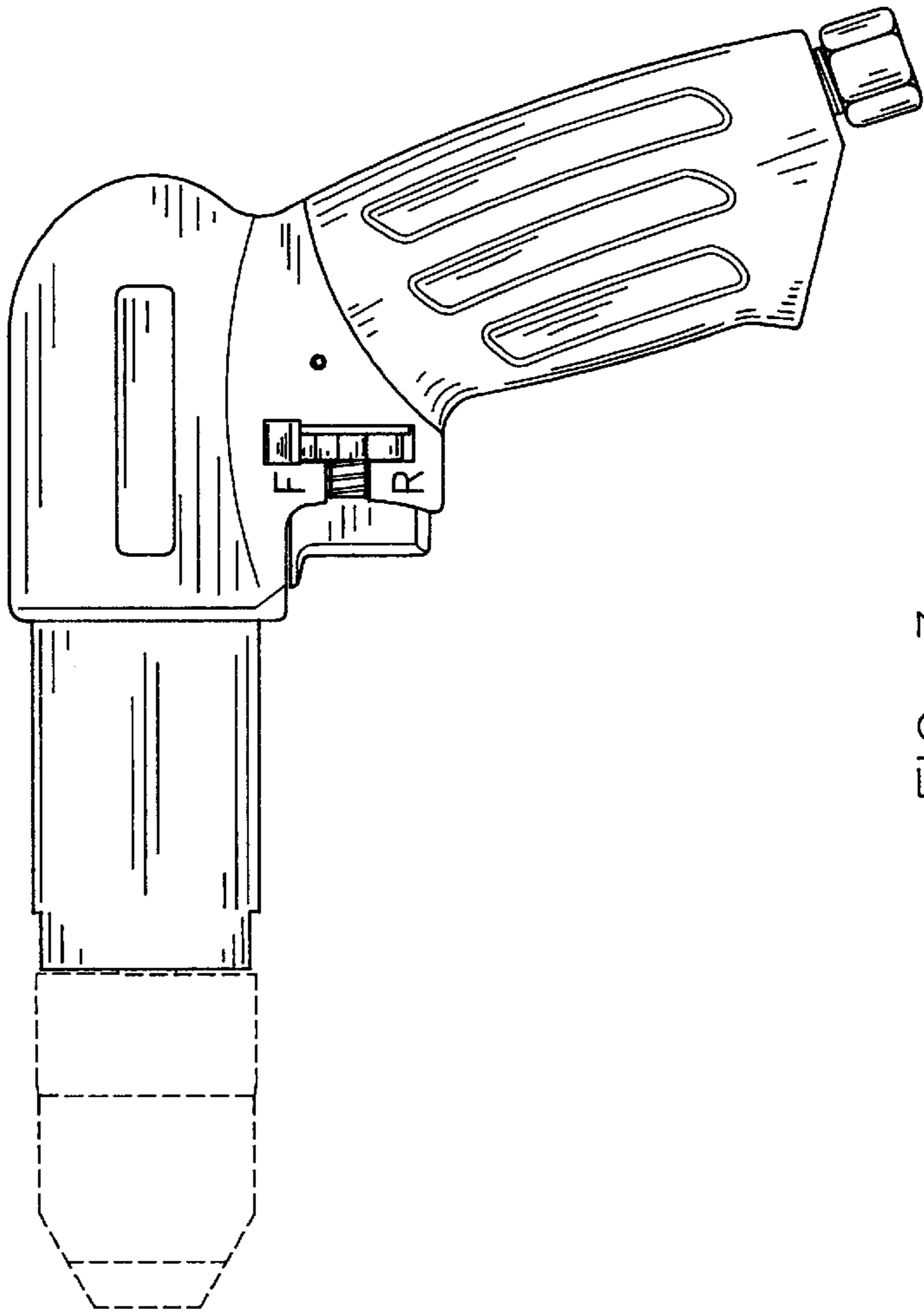

FIG. 3

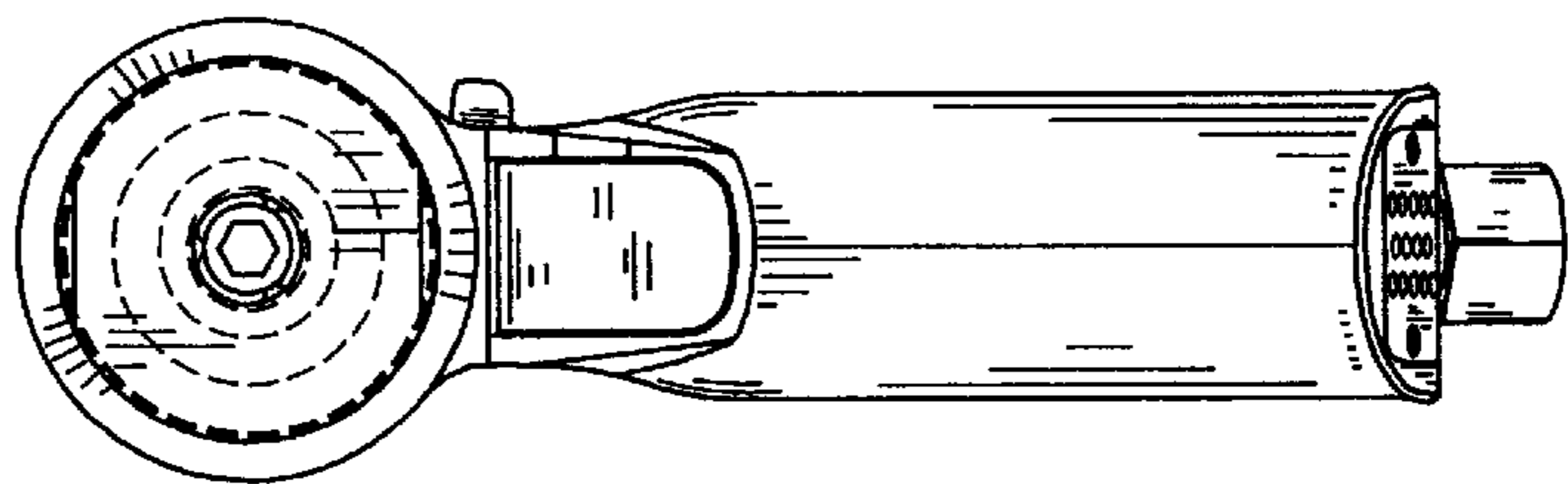

FIG. 2

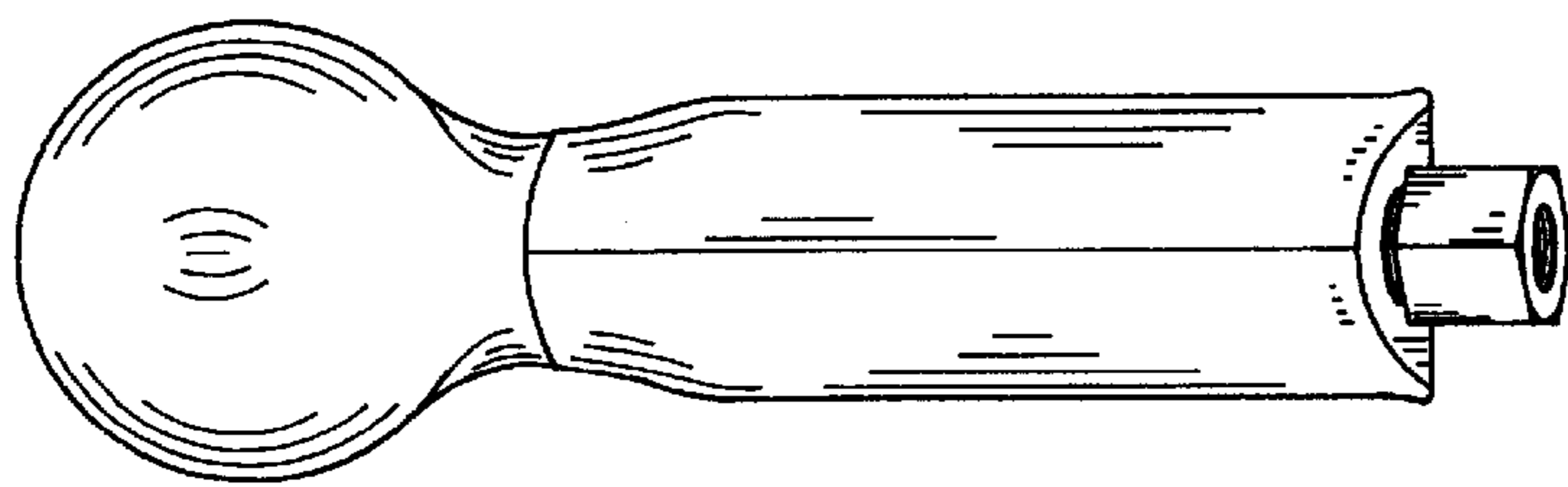

FIG. 4

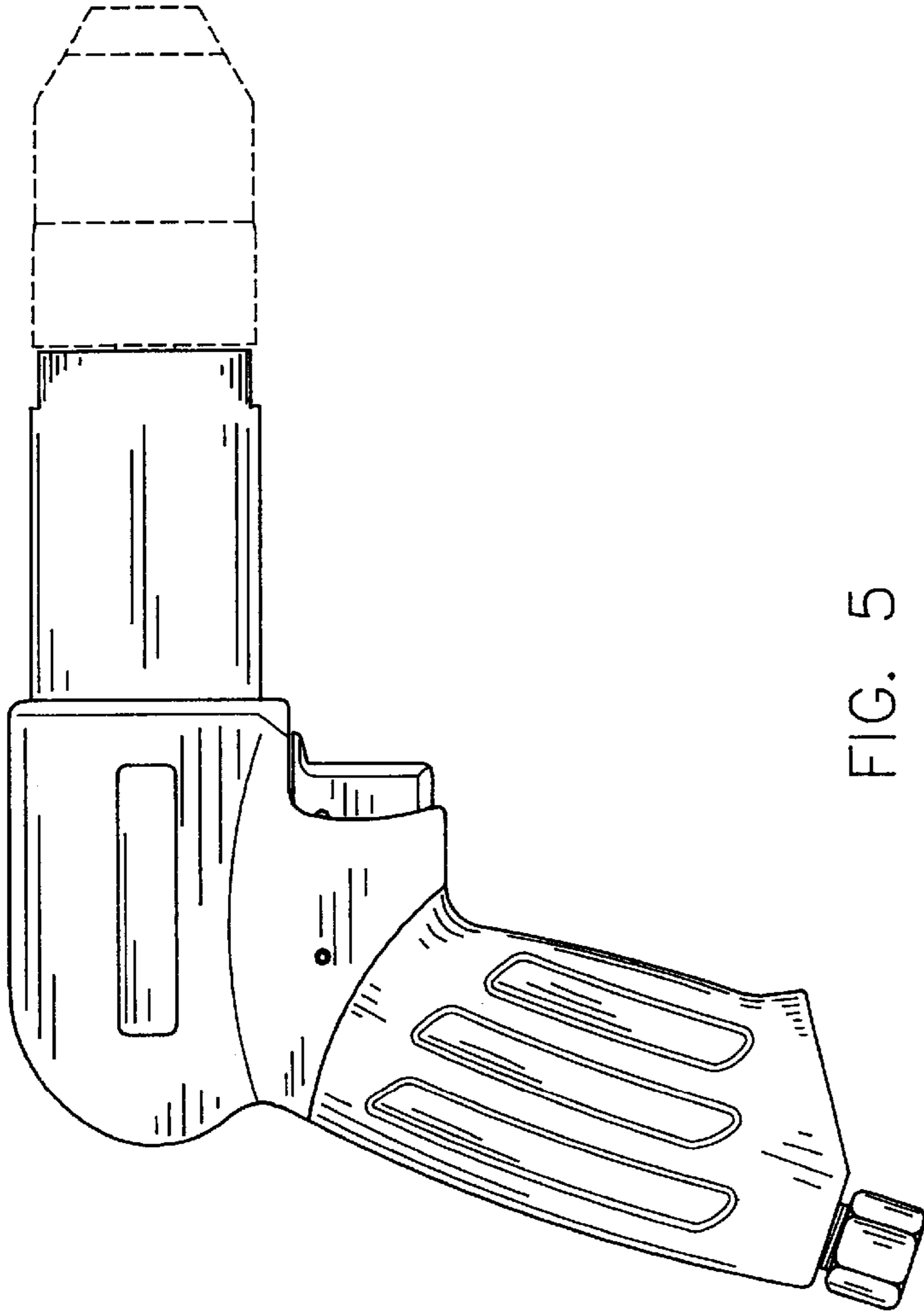

FIG. 5

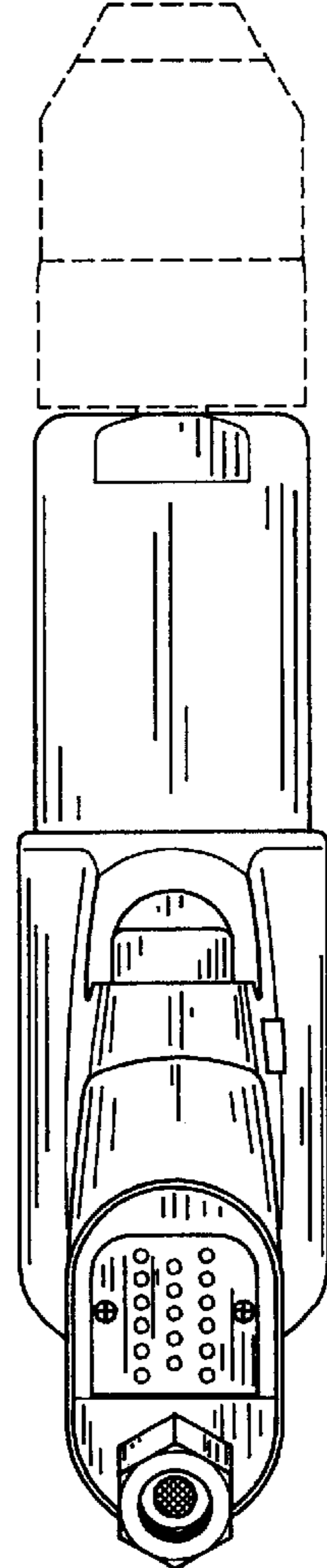

FIG. 6