



US00D459493S

(12) **United States Design Patent**
Thornton et al.

(10) **Patent No.:** **US D459,493 S**

(45) **Date of Patent:** **** Jun. 25, 2002**

(54) **RAILWAY TIE**

(76) Inventors: **Patrick Thornton**, 33 Bridge Avenue,
Oak Flats (AU), 2529; **Kevin James Walsh**, 109 Daltons Road, Jamberoo,
both of New South Wales (AU), 2533

(**) Term: **14 Years**

(21) Appl. No.: **29/137,882**

(22) Filed: **Mar. 2, 2001**

(51) **LOC (7) Cl.** **25-01**

(52) **U.S. Cl.** **D25/126**

(58) **Field of Search** 238/29-27; D25/126

(56) **References Cited**

U.S. PATENT DOCUMENTS

3,289,940 A * 12/1966 Groff 238/29
D243,613 S * 3/1977 Hilfiker D25/126

* cited by examiner

Primary Examiner—Doris Clark

(74) *Attorney, Agent, or Firm*—Barnes & Thornburg

(57) **CLAIM**

We claim the ornamental design for a railway tie, as shown and described.

DESCRIPTION

FIG. 1 is a perspective view of a first embodiment of a railway tie according to the principles of the present invention.

FIG. 2 is a side view of the first embodiment.

FIG. 3 is a bottom view of the first embodiment.

FIG. 4 is an end view of the first embodiment.

FIG. 5 is a perspective view of the second embodiment of the present invention.

FIG. 6 is a side view of the second embodiment.

FIG. 7 is a bottom view of the second embodiment; and,

FIG. 8 is an end view of the second embodiment.

The broken line shown in the Drawings are used to designate features of varying length.

1 Claim, 4 Drawing Sheets

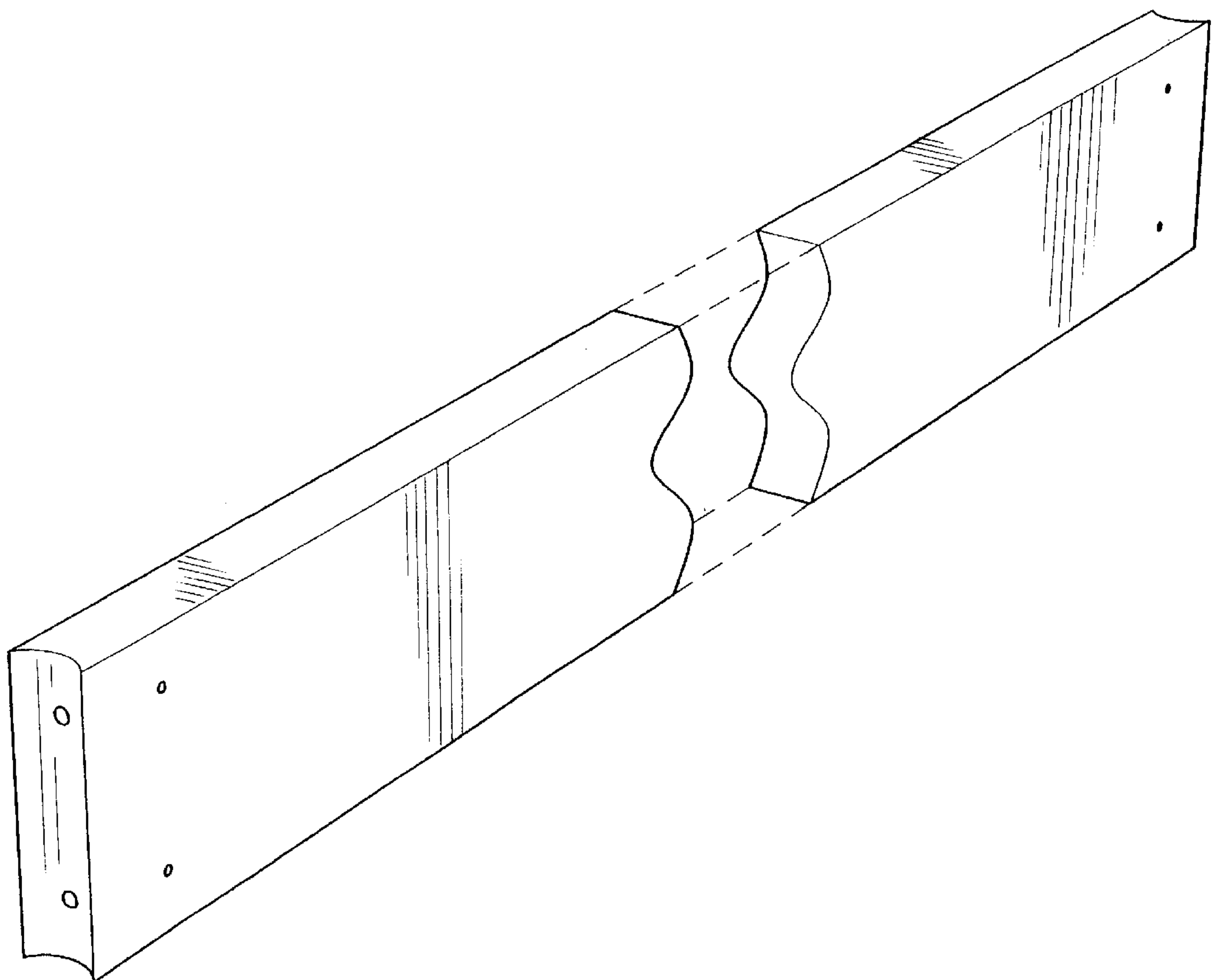

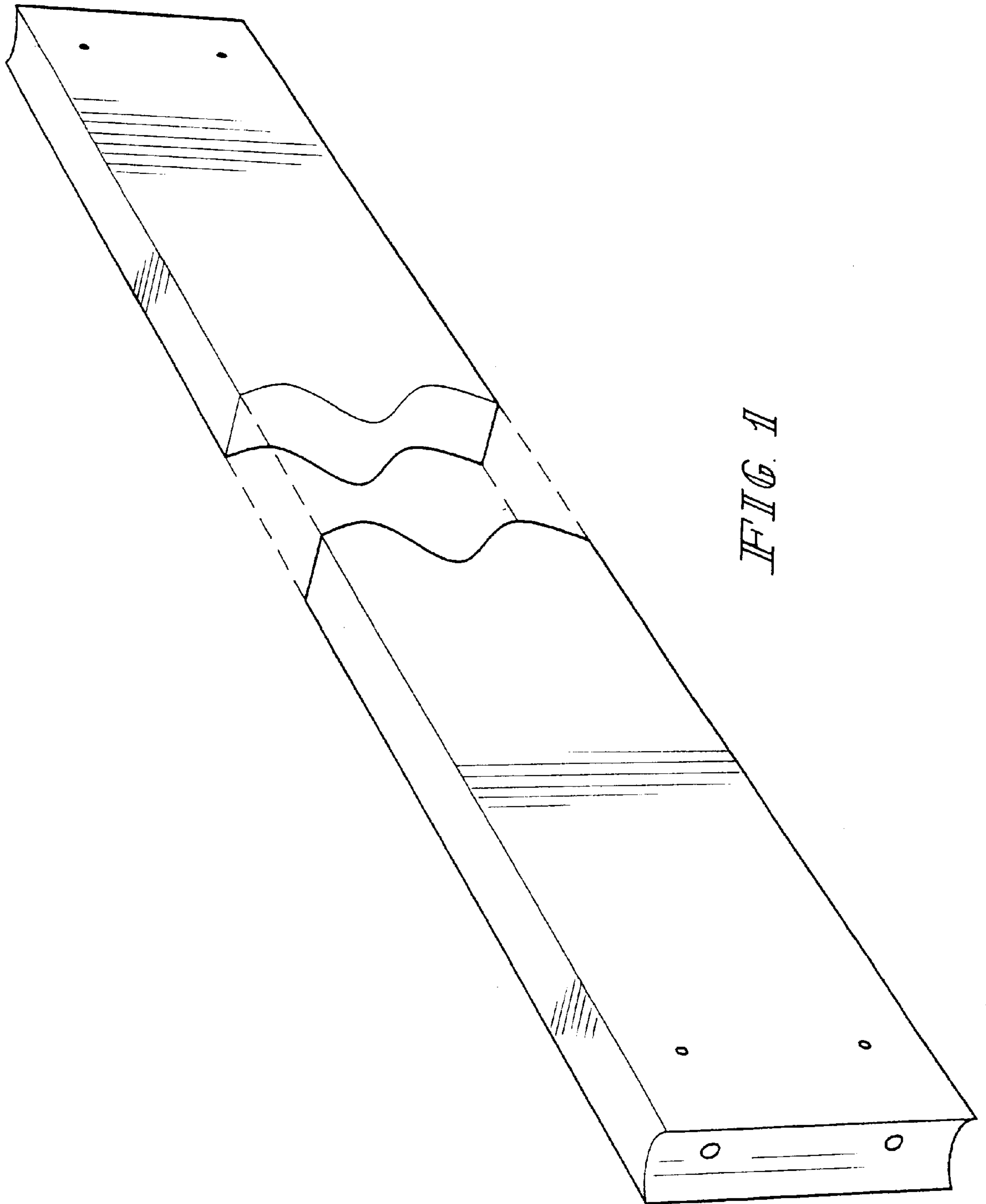

FIG. 1

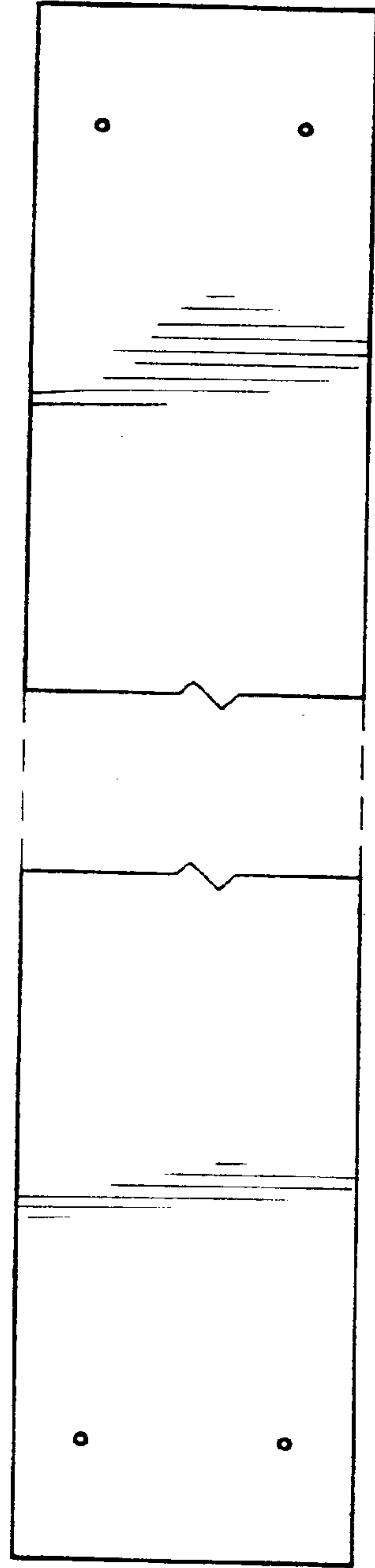

FIG. 2

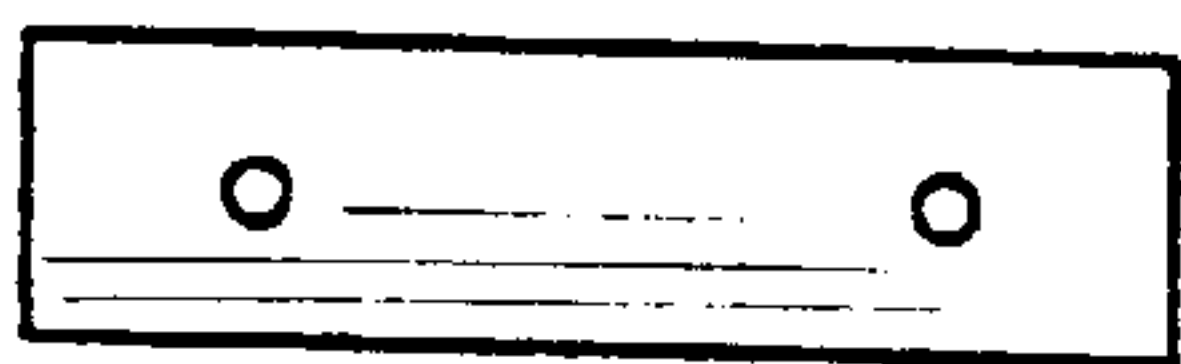

FIG. 4

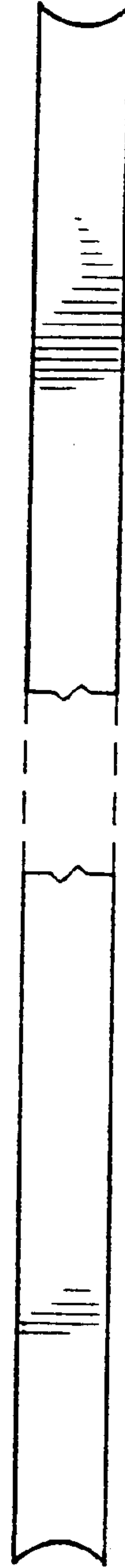

FIG. 3

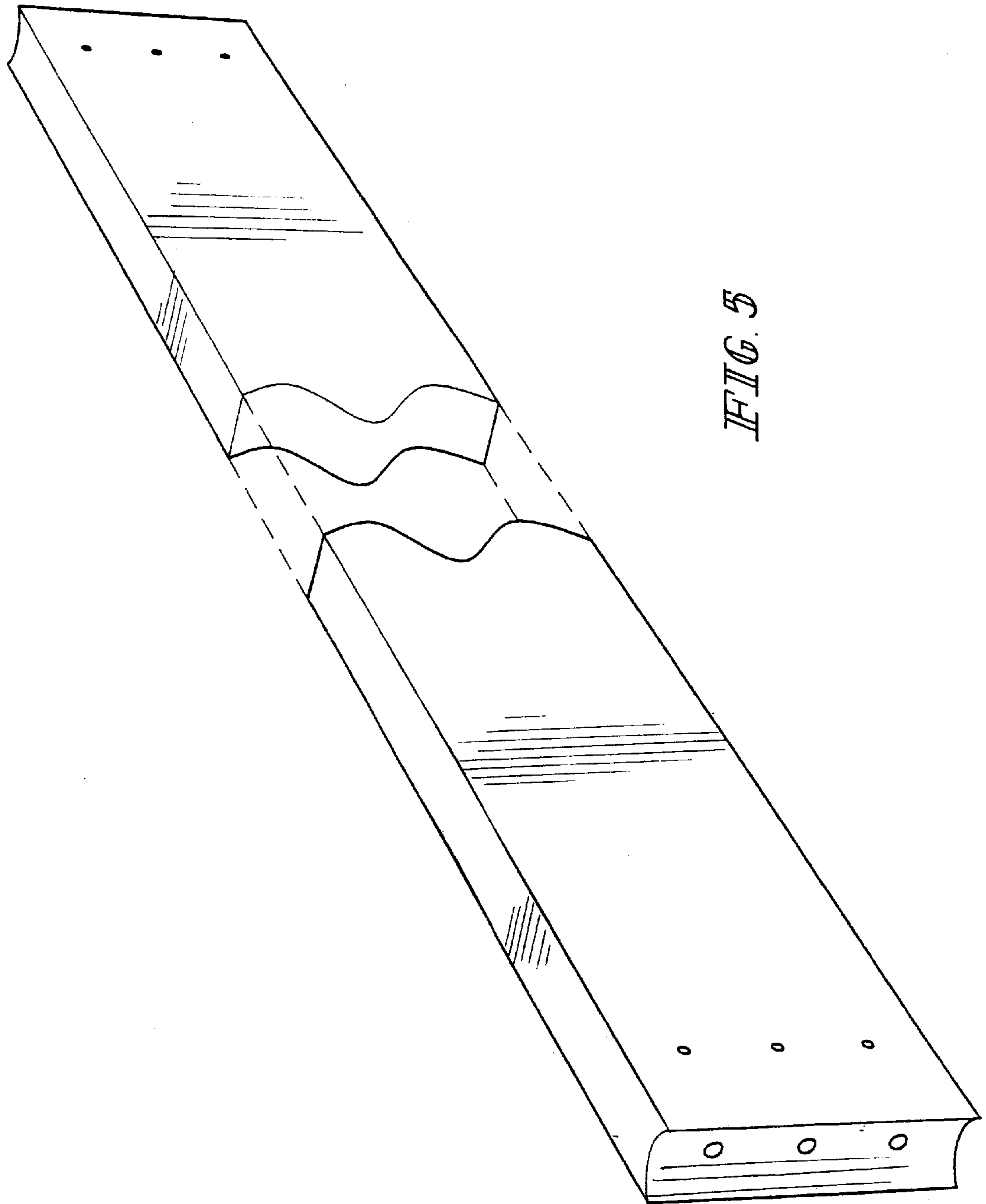

FIG. 5

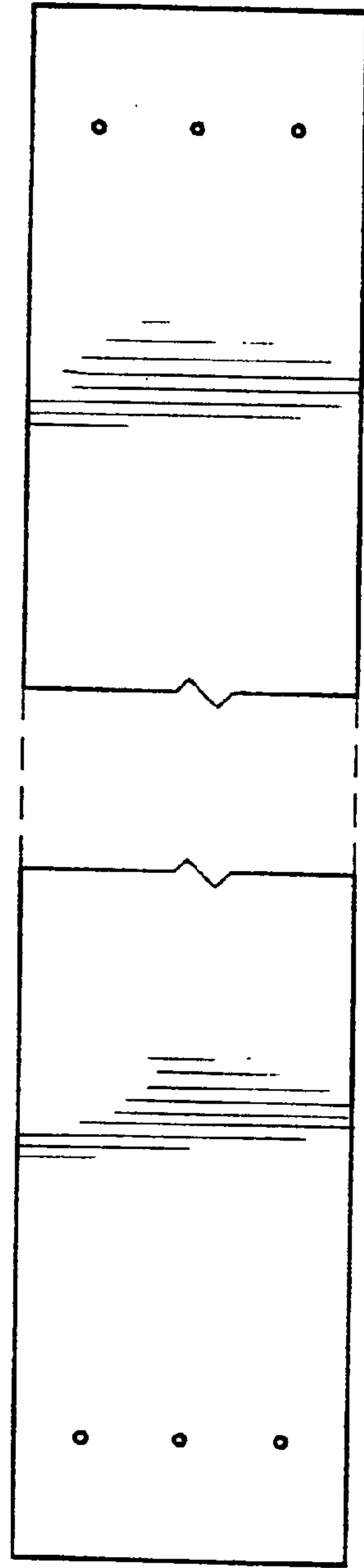

FIG. 6

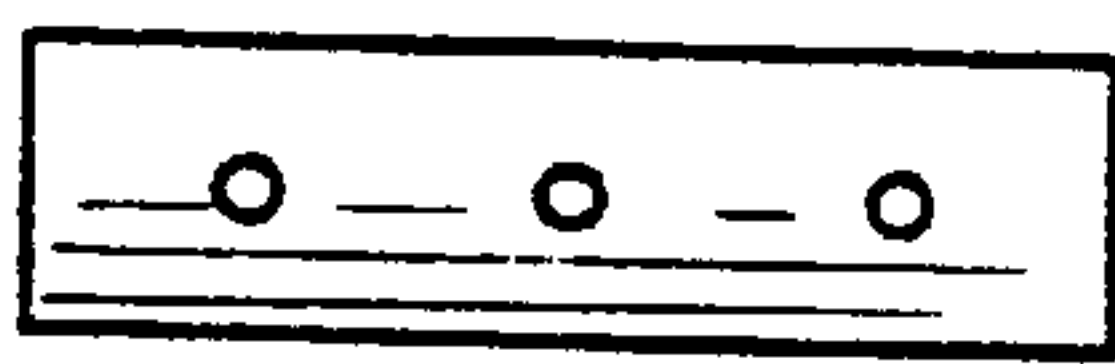

FIG. 8

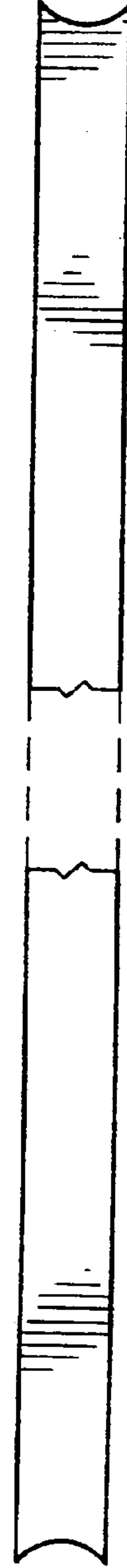

FIG. 7