



US00D459317S

(12) **United States Design Patent**
Fukumoto et al.

(10) **Patent No.:** **US D459,317 S**

(45) **Date of Patent:** **** Jun. 25, 2002**

(54) **SEMICONDUCTOR DEVICE**

6,300,685 B1 * 10/2001 Hasegawa et al. 257/780

(75) Inventors: **Takakazu Fukumoto; Muneharu Tokunaga; Tetsuya Matsuura**, all of Tokyo (JP)

(73) Assignee: **Mitsubishi Denki Kabushiki Kaisha**, Tokyo (JP)

(**) Term: **14 Years**

(21) Appl. No.: **29/144,821**

(22) Filed: **Jul. 12, 2001**

(30) **Foreign Application Priority Data**

Feb. 15, 2001 (JP) 2001-003333

(51) **LOC (7) Cl.** **13-03**

(52) **U.S. Cl.** **D13/182**

(58) **Field of Search** D13/182, 110; 174/52.2, 52.4, 16.3; 257/787, 668, 667, 670, 676, 679, 686, 688, 690, 692, 696, 703, 778; 361/760, 783, 813, 752, 798, 820; 365/226

(56) **References Cited**

U.S. PATENT DOCUMENTS

3,706,840 A	*	12/1972	Moyle et al.	174/52.2
4,748,538 A	*	5/1988	Tsuji	361/715
4,843,695 A	*	7/1989	Doe et al.	29/827
5,237,201 A	*	8/1993	Tanaki et al.	257/666
D345,731 S	*	4/1994	Owens et al.	D13/182
5,464,054 A	*	11/1995	Hinshaw et al.	165/80.3
D416,872 S	*	11/1999	Burke	D13/182
6,020,625 A	*	2/2000	Qin et al.	257/666
D421,969 S	*	3/2000	Kawafuji et al.	D13/182
6,093,957 A	*	7/2000	Kwon	257/666
D432,096 S	*	10/2000	Jeon et al.	D13/182
D432,097 S	*	10/2000	Song et al.	D13/182
D448,740 S	*	10/2001	Iwasaki et al.	D13/182

FOREIGN PATENT DOCUMENTS

JP	63-73694	4/1988
JP	63-114245	5/1988
JP	2-134890	5/1990
JP	4-276649	10/1992
JP	6-177501	6/1994
JP	6-314885	11/1994
JP	6-334294	12/1994
JP	7-22727	1/1995
JP	10-173122	6/1998

* cited by examiner

Primary Examiner—Ted Shooman

Assistant Examiner—Selina Sikder

(74) *Attorney, Agent, or Firm*—Oblon, Spivak, McClelland, Maier & Neustadt, P.C.

(57) **CLAIM**

The ornamental design for a semiconductor device, as shown and described.

DESCRIPTION

FIG. 1 is a front, top and right side perspective view of a semiconductor device, showing our new design;

FIG. 2 is a front, bottom and right side perspective view thereof;

FIG. 3 is a front elevational view thereof;

FIG. 4 is a rear elevational view thereof;

FIG. 5 is a right side elevational view thereof; the left side elevational view is omitted as that is symmetrical to the right side elevational view thereof;

FIG. 6 is a top plan view thereof;

FIG. 7 is a bottom plan view thereof; and,

FIG. 8 is a cross-sectional view thereof, taken along line 8—8 of FIG. 5, with the internal system omitted.

1 Claim, 4 Drawing Sheets

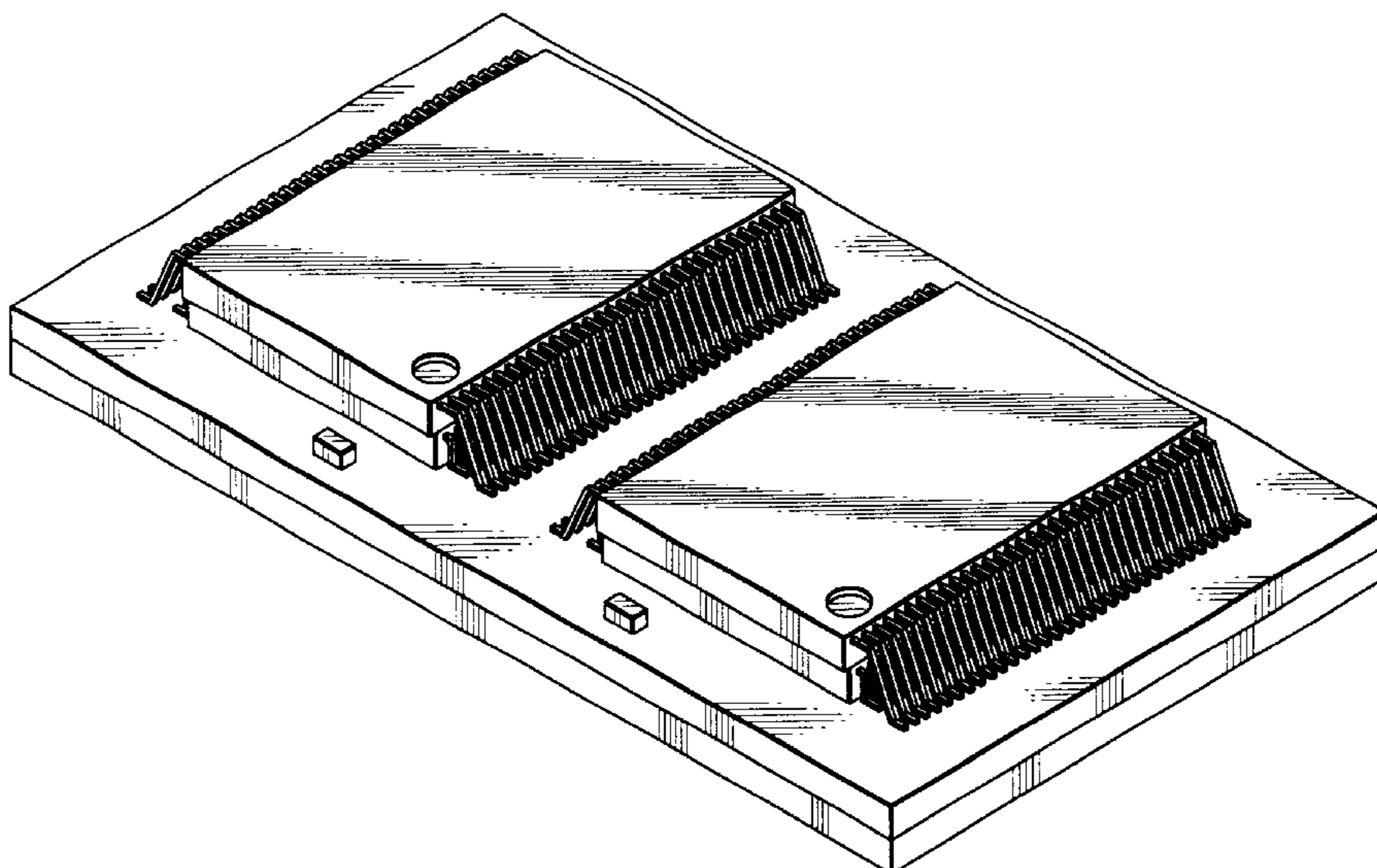

FIG. 1

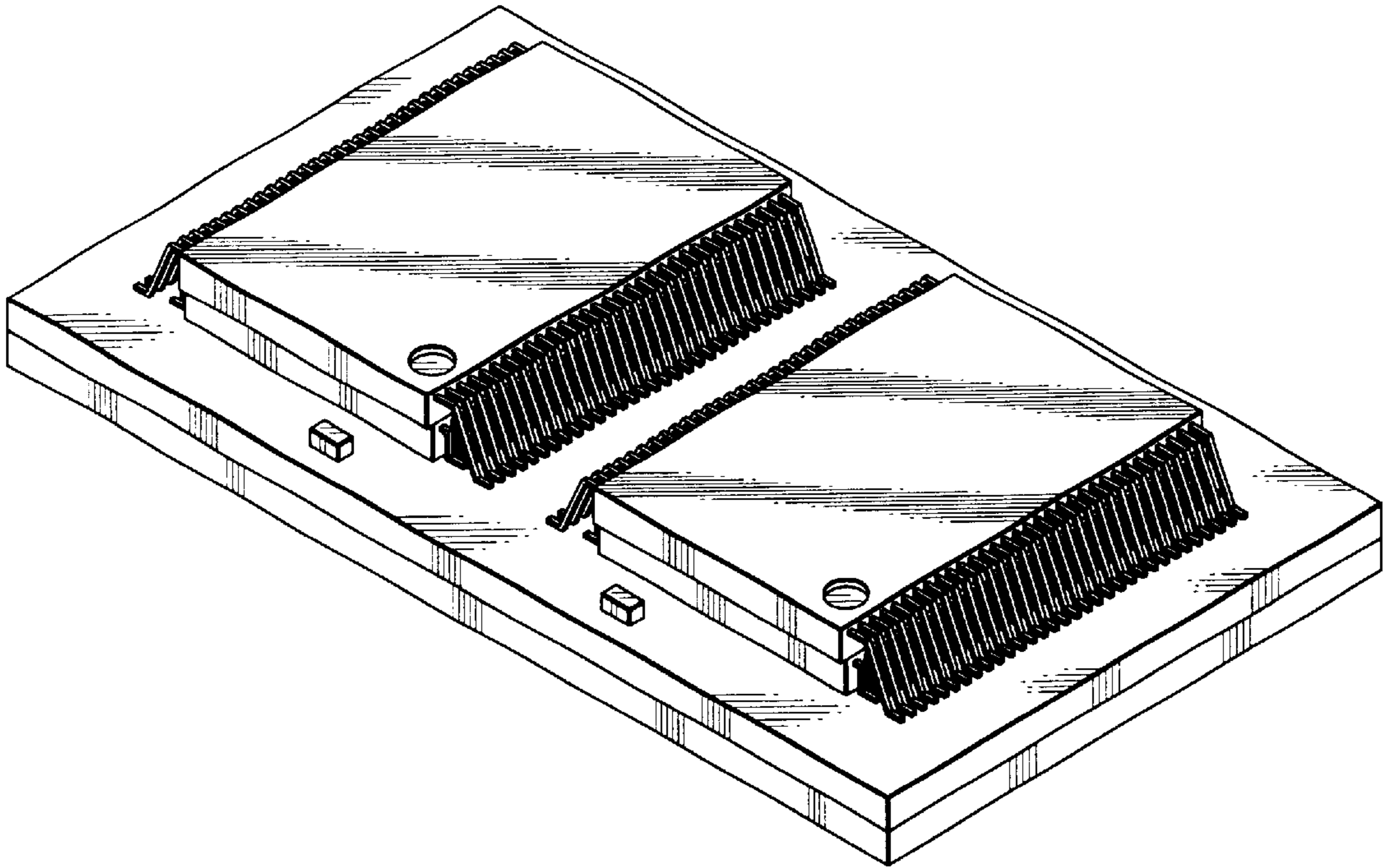

FIG. 2

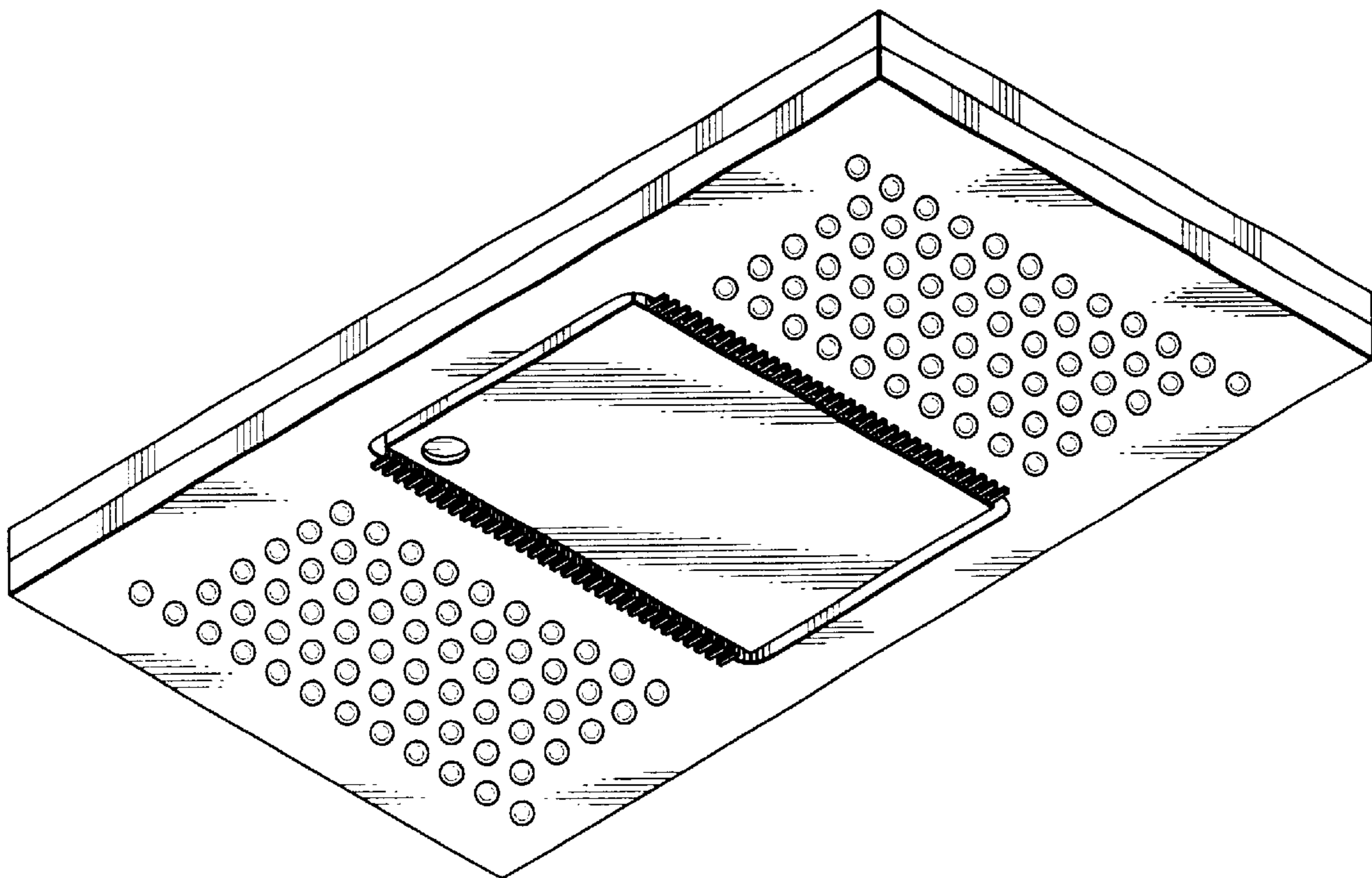

FIG. 3

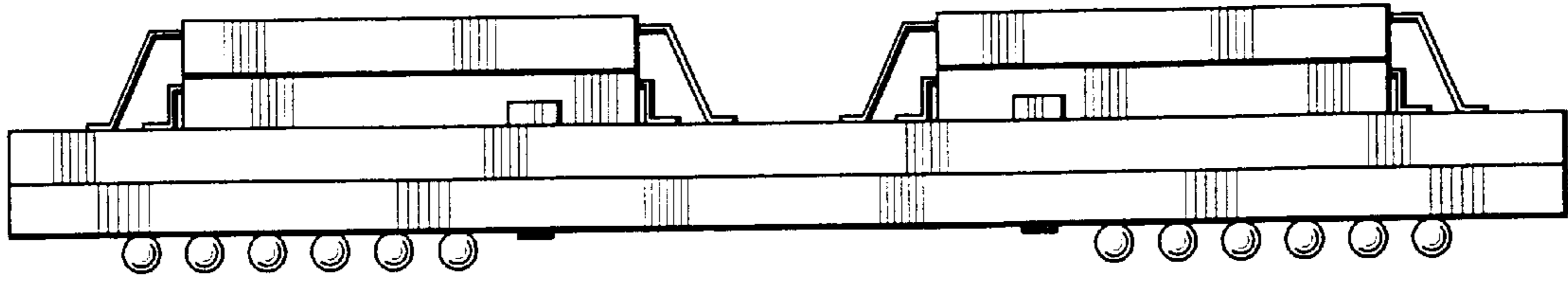

FIG. 4

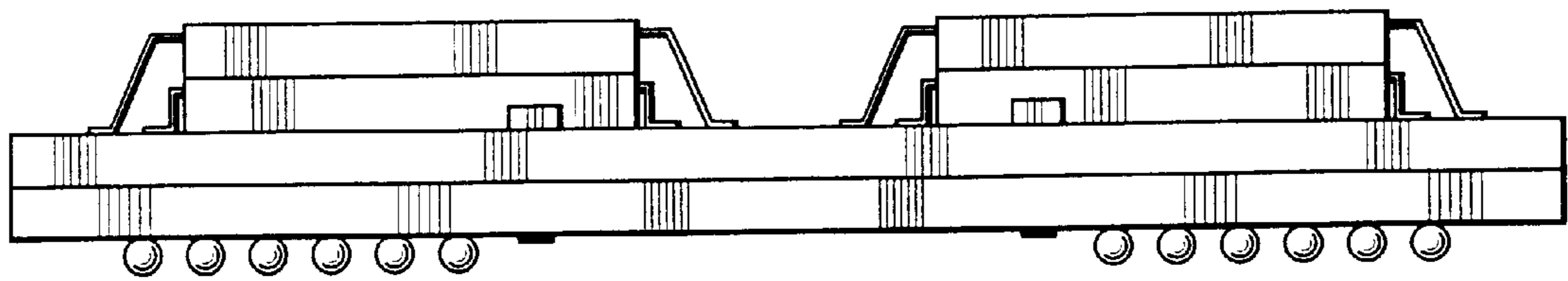

FIG. 5

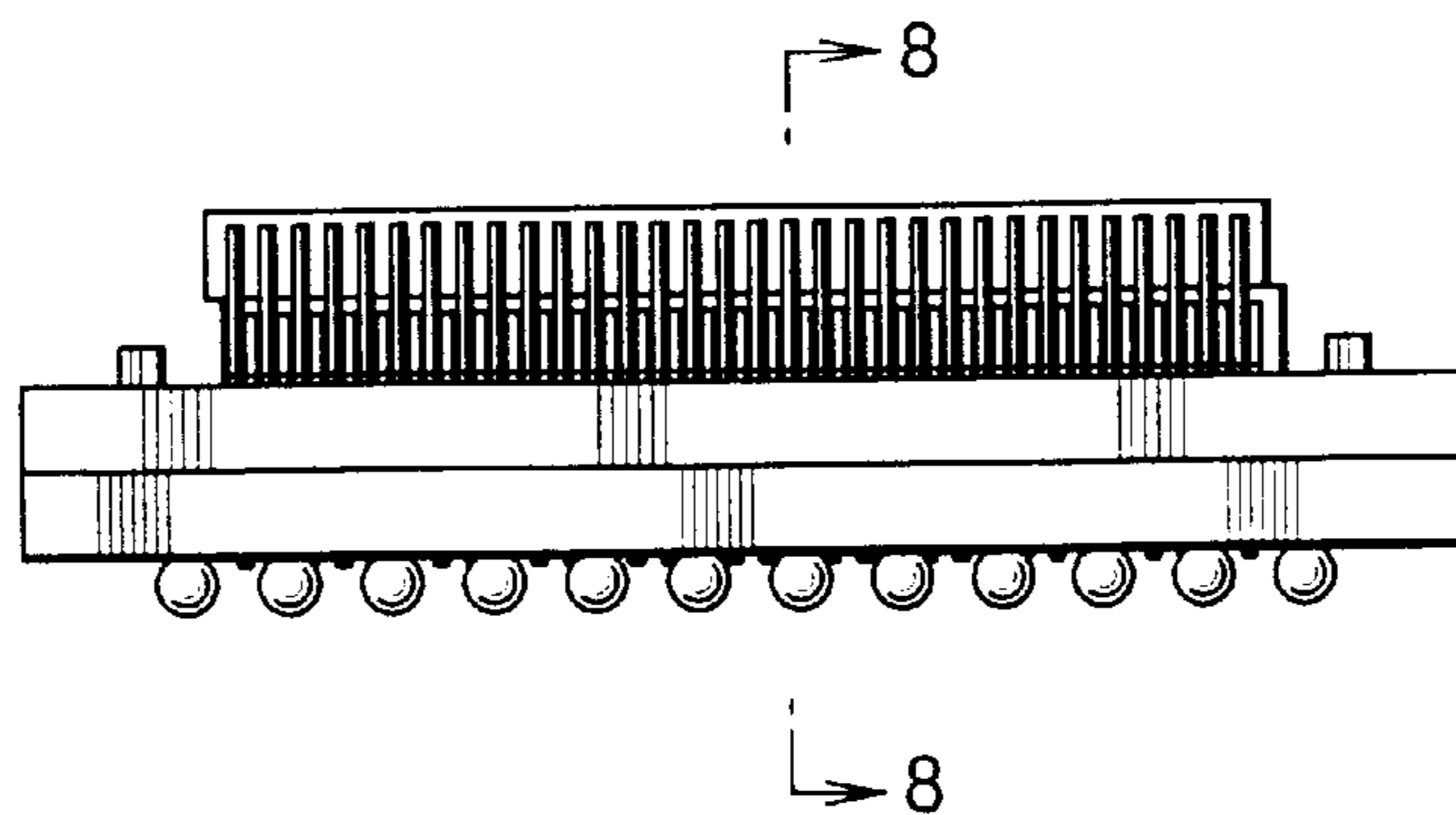

FIG. 6

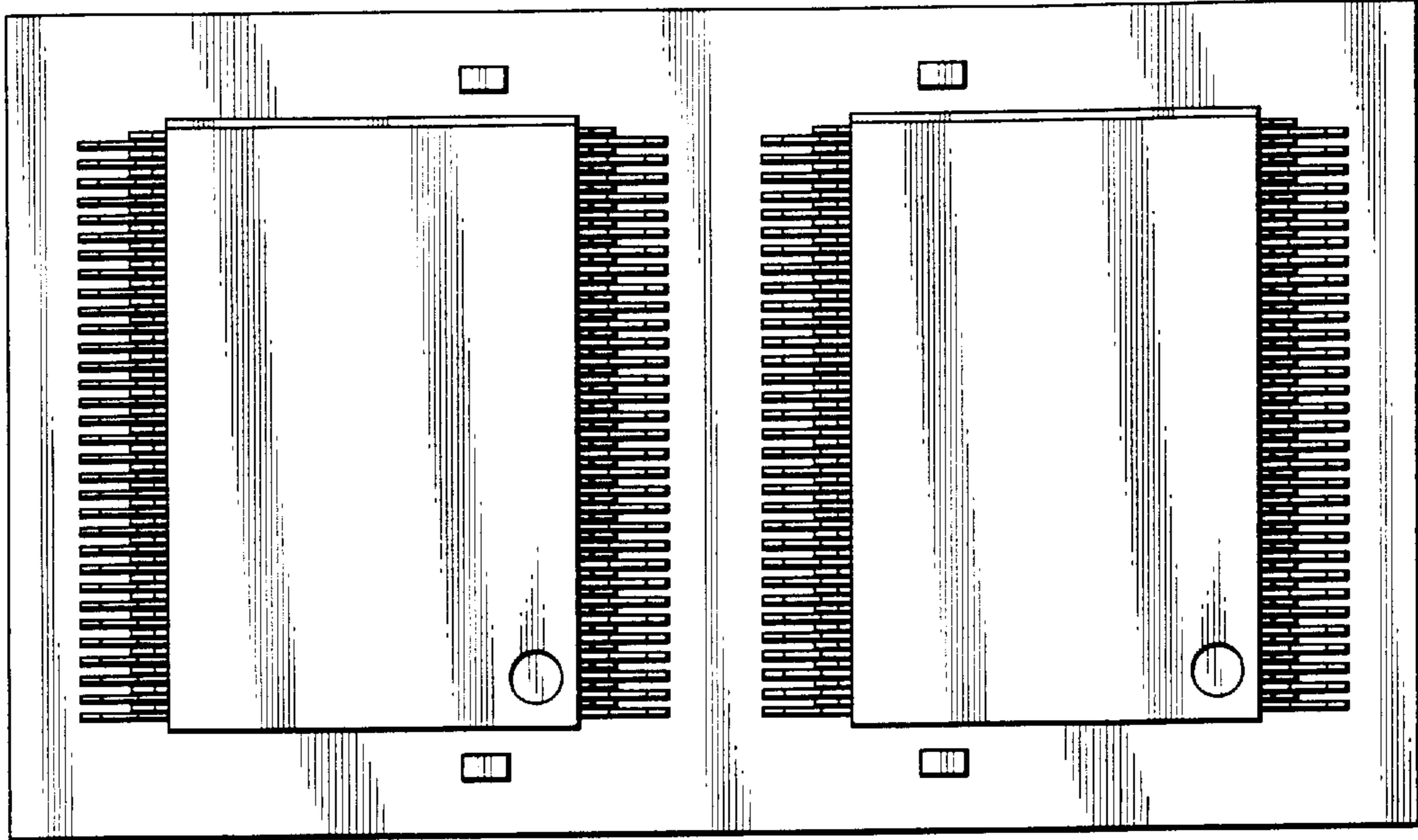

FIG. 7

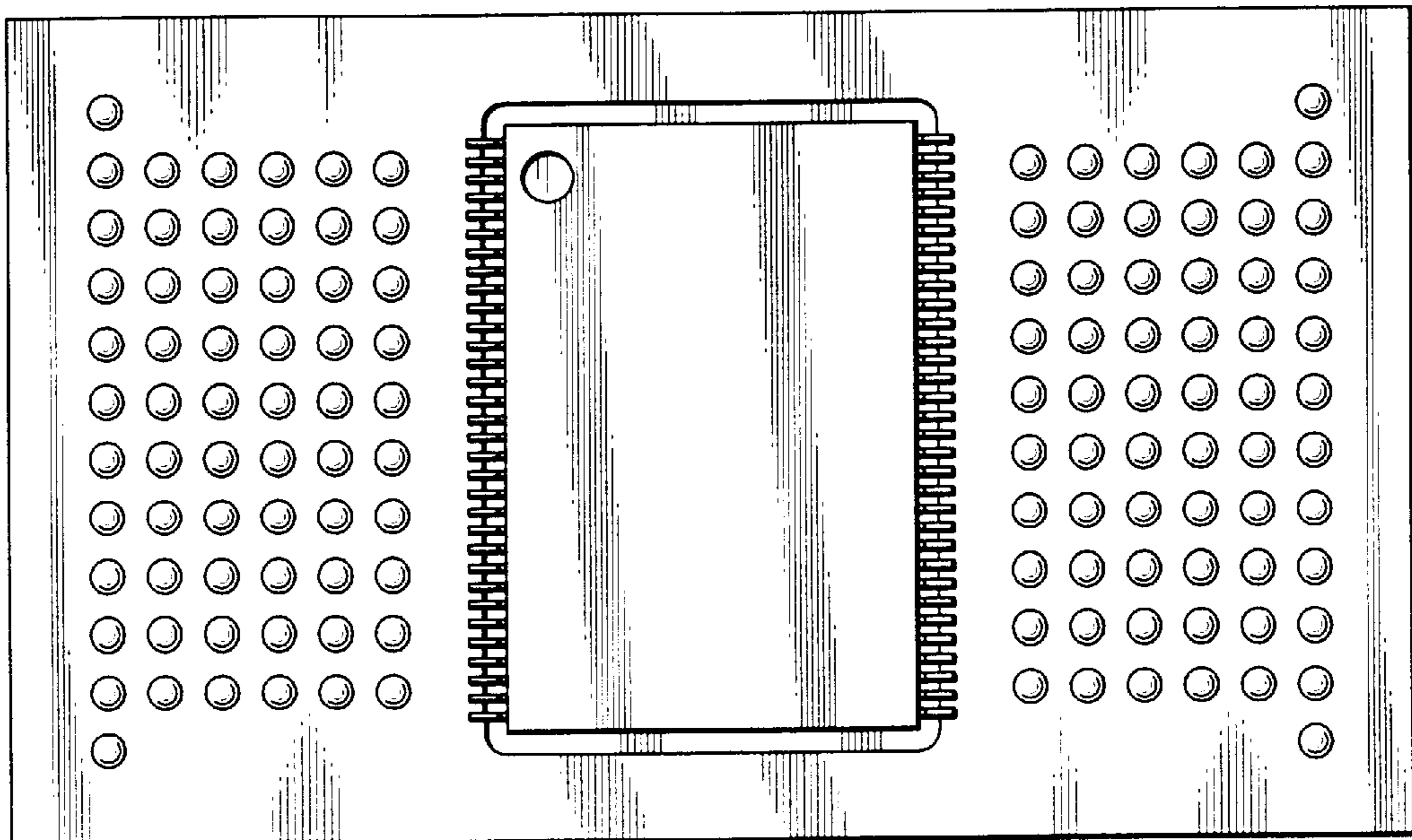

FIG. 8

